

Evaluation Board Report

Triple output 4.85W ACDC power supply

Design Specs	Value	Unit
Input Voltage	85-265	VAC
Output 1	13.5V, 300mA	
Output 2	8V, 50mA	
Output 3	8V, 50mA	
Isolation	YES	
MPS IC	MP110GPR	
Application	Power supply for meter AC-DC power supply with additional outputs	

Document Number	EBXXX
Author	Application Engineering Department
Date	Nov, 2014
Revision	1.0

Design Summary

EV110-P-00A evaluation board provides a reference design for a universal offline power supply with triple outputs. It contains the complete specification of the power supply, a detailed circuit diagram, the entire bill of materials required to build the power supply, drawing of the power inductors and transformers, and test data of the most important performance.

DESCRIPTION

The MP110 is a flyback regulator with a 900V MOSFET integrated, targeting high AC input voltage application. The switching frequency can be programmed with one external resistor

The EV110-P-00A Evaluation Board is designed to demonstrate the capabilities of MP110 and is also designed for off-line high input voltage (85VAC~420VAC) application with triple outputs (13.5V/300mA, 8V/50mA, 8V/50mA). The 8V output rail can power the LDO for MCU power supply.

The EV110-P-00A has an excellent performance and meets EN55022 conducted EMI requirements easily with frequency jittering function. It has various protections like Over Temperature Protection (OTP), VCC Under Voltage Lockout (UVLO), Over Load Protection (OLP), Over Voltage Protection (OVP), Short Circuit Protection (SCP) and built-in PRO pin for extra protection setting.

ELECTRICAL SPECIFICATION

Parameter	Symbol	Value	Units
Input Voltage	V_{IN}	85 to 420	VAC
Output1 Voltage	V_{OUT1}	13.5	V
Output1 Current	I_{OUT1}	300	mA
Output2 Voltage	V_{OUT2}	8	V
Output2 Current	I_{OUT2}	50	mA
Output3 Voltage	V_{OUT3}	8	V
Output3 Current	I_{OUT3}	50	mA

FEATURES

- Internal Integrated 900V MOSFET
- Programmable switching frequency up to 300kHz
- Frequency jittering
- Current-mode operation
- Internal high voltage current source
- Low standby power consumption via active burst mode
- Internal leading-edge blanking
- Built-in soft-start function
- Internal slope compensation
- Built-in PRO pin pull-up auto restart function
- Over-temperature protection
- V_{CC} under-voltage lockout with hysteresis
- Over-voltage protection on V_{CC}
- Time-based over-load protection
- Short-circuit protection

All MPS parts are lead-free and adhere to the RoHS directive. For MPS green status, please visit MPS website under Quality Assurance. "MPS" and "The Future of Analog IC Technology", are Registered Trademarks of Monolithic Power Systems, Inc.



Warning: Although this board is designed to satisfy safety requirements, the engineering prototype has not been agency approved. Therefore, all testing should be performed using an isolation transformer to provide the AC input to the prototype board.

EV110- P-00A EVALUATION BOARD



TOP VIEW

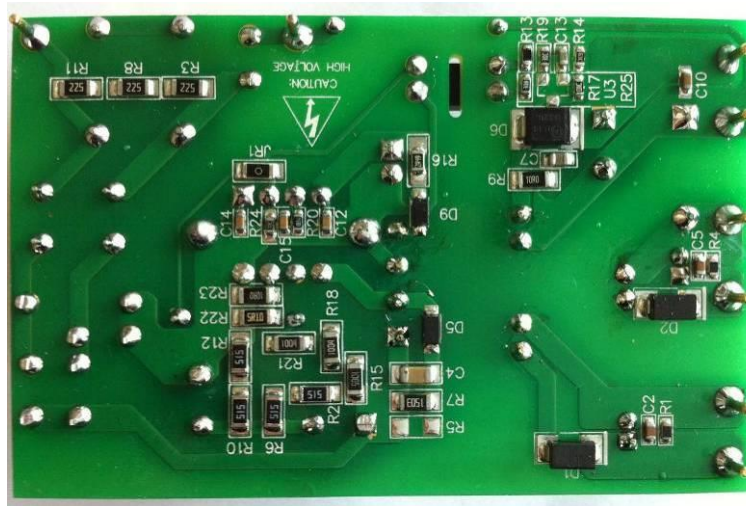

BOTTOM VIEW

(L x W x H) 74mm x 47mm x 22mm

Board Number	MPS IC Number
EV110-P-00A	MP110GPR

EVALUATION BOARD SCHEMATIC

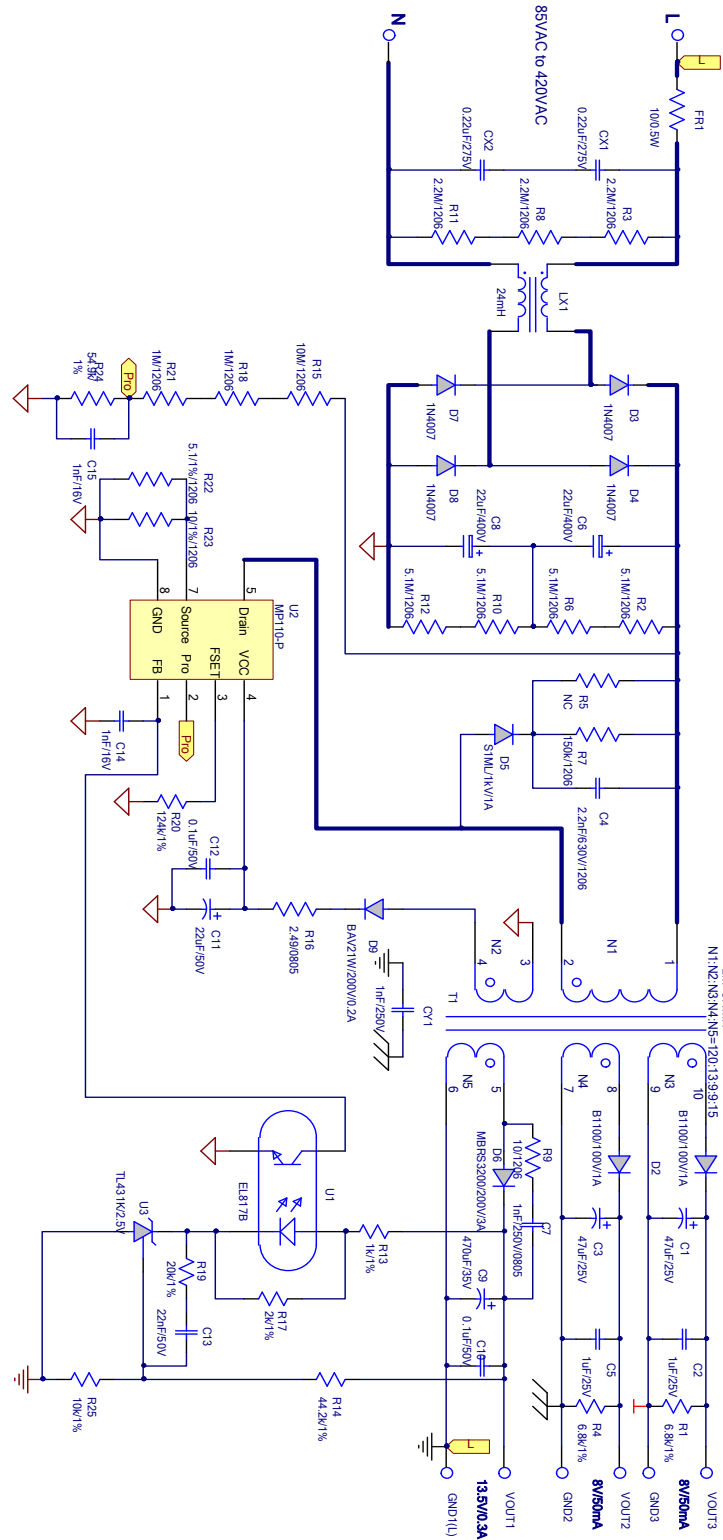

Figure 1—Schematic

CIRCUIT DESCRIPTION

The EV110-P-00A is configured for 5W triple outputs in power meter application. The 8V output rail can power the LCD for MCU power supply. The demo board is proper for three phase input power system.

FR1 is used to protect for the component failure or some excessive short events, also it can restrain the inrush current.

The CX1, CX2 and LX1 compose the EMI filter to guarantee the conducted EMI meet the EN55022 criteria. CX1 is in series with CX2 for 420VAC input. R3, R8 and R11 are used to discharge the energy stored in CX1 and CX2 in 1 second for safety requirement.

D3, D4, D7 and D8 compose the input stage to commute the AC voltage to DC voltage.

The C6 and C8 are used for energy storage reducing line noise and protecting against line surge. R2, R6, R10 and R12 is for balancing the voltage of C6 and C8.

R7, C4 and D5 are formed the RCD to restrain the high voltage spike to protect the MOSFET.

R20 is for switching frequency setup. Normally, the switching frequency is configured around

100kHz to avoid the frequency noise disturbing to data sample in power meter application.

C11 is the power supply capacitor and C12 is the decoupling ceramic cap to decouple the voltage noise spike. C12 should be located near to IC.

R22, R23 are the sense resistors with 1% tolerance for peak current setup.

R15, R16, R21 and R24 are configured for input over voltage protection. C15 is used to filter the input voltage noise disturbance.

C1, C3, C9 are the output filter capacitor to restrain the output voltage ripple. One filter could be used for strict voltage ripple requirement.

R1, R4 are dummy load to regulate the output voltage within designed value.

R14, R25 are configured to set the output voltage. U1, U3, R19 and C13 compose the control loop to feedback the output signal to FB pin and guarantee the quick control loop response and system stability.

Input Line wire is connected to GND(L) of main output for input AC frequency sample in power meter.

EV4050-S-00A BILL OF MATERIALS

Qty	Ref	Value	Description	Package	Manufacturer	Manufacturer_P/N
2	C1, C3	47µF	Ceramic Capacitor;25V	DIP	Jianghai	CD28L-25V47
2	C2,C5	1µF	Ceramic Capacitor;25V;X7R	0603	Murata	GRM188R71E2105KA12D
1	C4,	2.2nF	Ceramic Capacitor;630V;X7R	0603	Murata	GRM31BR72J222KW01L
2	C6,C8	22µF	Electrolytic Capacitor;400V	DIP	Rubycon	400PX22MEFC12.5X20
2	C7	1nF	Ceramic Capacitor;250V;X7R	0805	Murata	GRM21A7U2E102JW31D
2	C9	470µF	Ceramic Capacitor;35V	DIP	Jianghai	CD263-35V470
2	C10,C12	100nF	Ceramic Capacitor;50V	0603	Murata	GRM188R71H104KA93D
1	C11	22µF	Electrolytic Capacitor;50V	DIP	Jianghai	CD281L-50V22
1	C13	22nF	Ceramic Capacitor;50V	0603	Murata	GRM188R71H223KA01D
2	C14,C15	1nF	Ceramic Capacitor;16V	0603	Jianghai	GRM188R71C102KA01
2	CX1, CX2	0.22µF	X Capacitor;275V;10%	DIP	Carli	PX224K3IC59L270D9R
1	CY1	1nF	Y Capacitor;250V;20%	DIP	Hongke	JNK09E102MY02N
2	D1,D2	B1100	Schottky Diode;100V;1A	SMA	Diodes	B1100
4	D3, D4, D7,D8	1N4007	Diode;1000V;1A	DO41	Diodes	1N4007
1	D5	S1ML	Diode;1000V;1A;	SMA	Diodes	S1ML
1	D6	MBRS320	Schottky Diode;200V;3A	SMB	Onsemi	MBRS320
1	D9	BAV21W	Diode;200V;0.2A;	SOD123	Diodes	BAV21W
1	LX1	24mH	EE8, Common Choke,	DIP		FX0344
1	FR1	10	Fuse Resistor;5%;1/2W	DIP	CTC	FKN50SJT-52-10R
2	R1, R4	6.8k	Film Resistor;1%	0603	Yageo	RC0603FR-076K8L
4	R2, R6, R10, R12	5.1M	Film Resistor;5%;1/4W	1206	Yageo	RI1206L515JT
3	R3, R8, R11	2.2M	Film Resistor;5%;1/4W	1206	Royalohm	1206J0225T5E
1	R5	NC				
1	R7	150k	Film Resistor;5%;1/4W	1206	Yageo	RC1206FR-07150KL
2	R9,R23	10	Film Resistor;1%;1/4W	1206	Yageo	RC1206FR-0710RL
1	R13	1k	Film Resistor;1%	0603	Yageo	RC0603FR-071KL
1	R14	44.2k	Film Resistor;1%	0603	Yageo	RC0603FR-0744K2L
1	R15	10M	Film Resistor;5%;1/4W	1206	Royalohm	1206F1005T5E
1	R16	2.49	Film Resistor;1%	0805	Yageo	RC0805FR-072R49L

EV4050-S-00A BILL OF MATERIALS (continued)

Qty	Ref	Value	Description	Package	Manufacturer	Manufacturer_P/N
1	R17	2k	Film Resistor;1%	0603	Yageo	RC0603FR-072KL
2	R18,R21	1M	Film Resistor;5%;1/4W	1206	Yageo	1206F104T5E
1	R19	20k	Film Resistor;1%	0603	Yageo	RC0603FR-0720KL
1	R20	124k	Film Resistor;1%	0603	Yageo	RC0603FR-07124KL
1	R22	5.1	Film Resistor;1%;1/4W	1206	Yageo	RC1206FR-075R1L
1	R24	54.9k	Film Resistor;5%	0603	Yageo	RC0603FR-0754K9L
1	R25	10k	Film Resistor;1%	0603	Yageo	RC0603FR-0710KL
1	JR1	0	Film Resistor;1%	1206	Yageo	RC1206FR-070KL
1	T1	EE16	EE16, 3.4mH, N1:N2:N3:N4:N5 =120:13:9:9:15	DIP	Würth ⁽¹⁾	750342058
					Emei ⁽²⁾	FX0337
1	U2	MP110	Flyback regulator with 900V integrated MOS	DIP8EP	MPS	MP110-P R5
1	U1	EL817B	Photocoupler;1- Channel	DIP	Everlight	EL817B
1	U3	TL431	2.5V voltage reference	SOT23	Diodes	TL431

Note:

- (1) Würth transformer sample request please login on website: www.we-online.com
(2) Emei transformer sample request please login on website: www.emeigroup.com

TRANSFORMER SPECIFICATION

Electrical Diagram

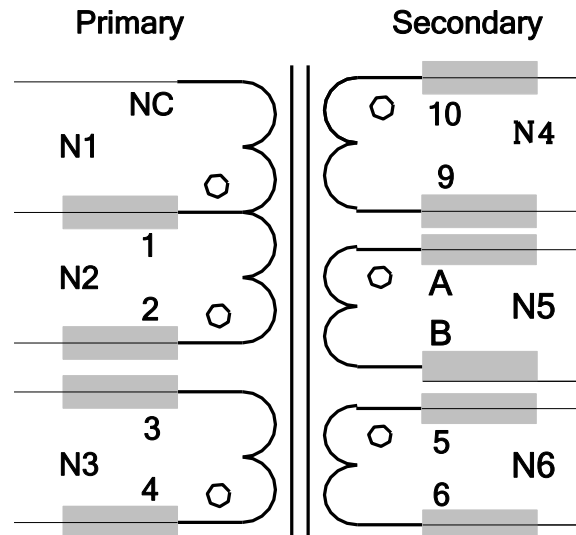

Figure 4—Transformer Electrical Diagram

Notes:

- 1、 All winding terminals are added tube;
- 2、 N5 is flying out from the bobbin. Terminal A is labeled with black and terminal B is labeled with white;
- 3、 Remove Pin7 and Pin8;
- 4、 Shield the transformer with copper foil and connect it to Pin3;
- 5、 Varnish the transformer.

Winding Diagram

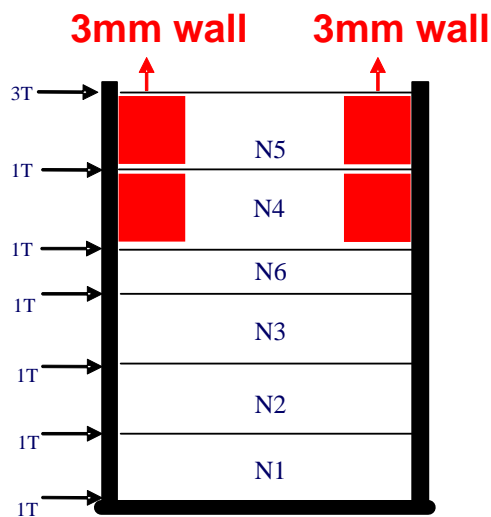

Figure 5—Winding Diagram

Winding Order

Winding No.	Tape Layer Number	Start & End	Magnet Wire Φ (mm)	Turns
N1	1	1→NC	0.18mm * 2	22
N2	1	2→1	0.15mm * 1	120
N3	1	4→3	0.15mm * 1	13
N6	1	5→6	0.30mm * 1 TIW	15
N4	1	10→9	0.16mm * 1 TIW	9
N5	1	A→B	0.16mm * 1 TIW	9

Electrical Specifications

Electrical Strength	60 second, 60Hz, from PRI. to SEC.	4500VAC
	60 second, 60Hz, from N4. to N6.	4500VAC
	60 second, 60Hz, from PRI. to CORE.	2500VAC
Primary Inductance	Pins 1 - 2, all other windings open, measured at 60kHz, 0.1 VRMS	3.4mH±10%
Primary Leakage Inductance	Pins 1 - 2 with all other pins shorted, measured at 60kHz. 0.1 VRMS	100μH±10%

Materials

Item	Description
1	Core: EE16, UI=2300±25%, AL=1100nH/N ² ±25% UNGAPPED/AL=236nH/N ² ±3% GAPPED
2	Bobbin: EE16 vertical, 4+6PIN 1SECT T-H
3	Wire: Φ 0.15mm,, 2UEW, Class B
4	Wire: Φ 0.18mm,, 2UEW, Class B
5	Triple Insulation Wire: Φ 0.30mm TIW
6	Triple Insulation Wire: Φ 0.16mm TIW
7	Tape: 8.5mm(W)×0.06mm(TH)
8	Margin tape: 3mm×0.28mm(TH)
9	Tube: #26 BLACK; #26 CLEAR; #30 CLEAR; #23 CLEAR
10	Copper foil: 5.0mmX 0.025mm(TH)
11	Varnish: JOHN C. DOLPH CO, BC-346A or equivalent
12	Solder Bar: CHEN NAN: SN99.5/Cu0.5 or equivalent

EVB TEST RESULTS

Performance Data

Ta=25°C, unless otherwise noted.

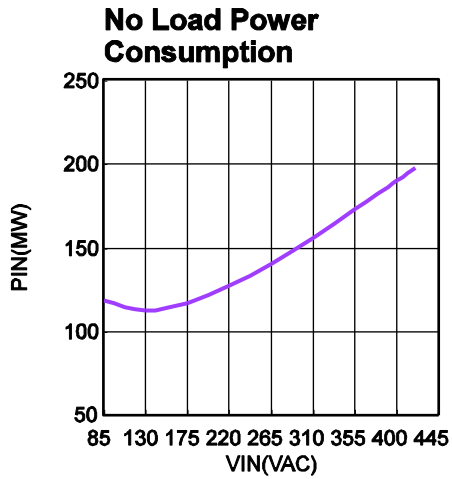
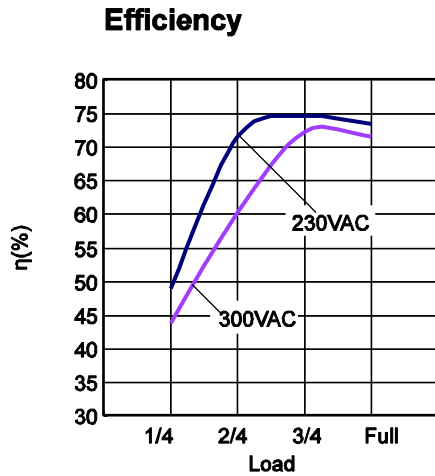

Conducted EMI Test

EV110-P-00A comply the EN55022 requirement.

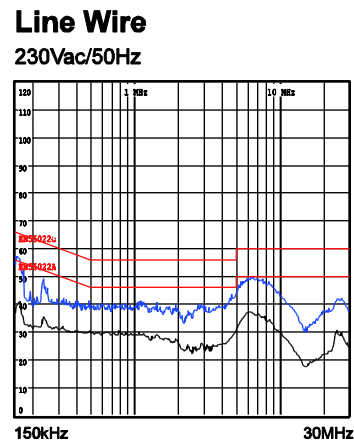
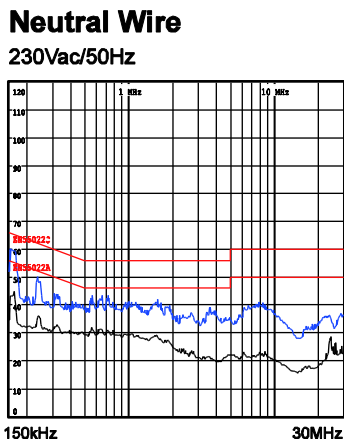

Thermal Test

$T_A=25^{\circ}\text{C}$

$V_{IN}=85\text{VAC}/420\text{VAC}$; $V_{OUT1}=13.5\text{V}$, $I_{OUT1}=300\text{mA}$; $V_{OUT2}=8\text{V}$, $I_{OUT2}=50\text{mA}$; $V_{OUT3}=8\text{V}$, $I_{OUT3}=50\text{mA}$.

$V_{IN}=85\text{VAC}$, Full Load.

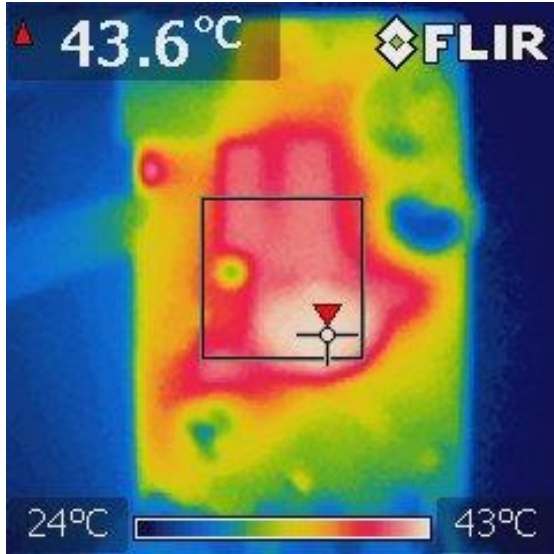

TOP

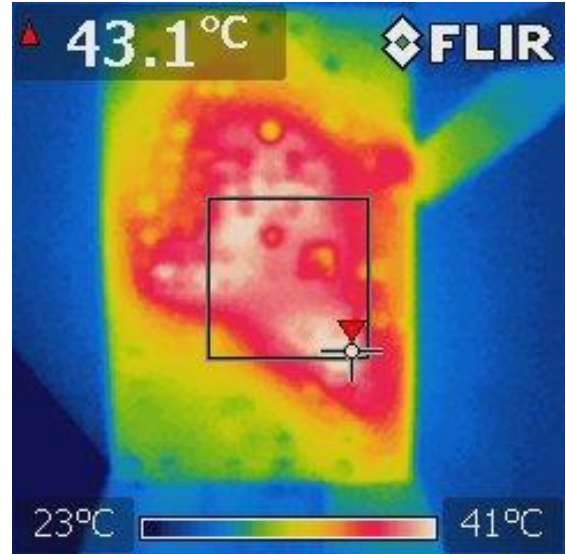

BOTTOM

$V_{IN}=420\text{VAC}$, Full Load.

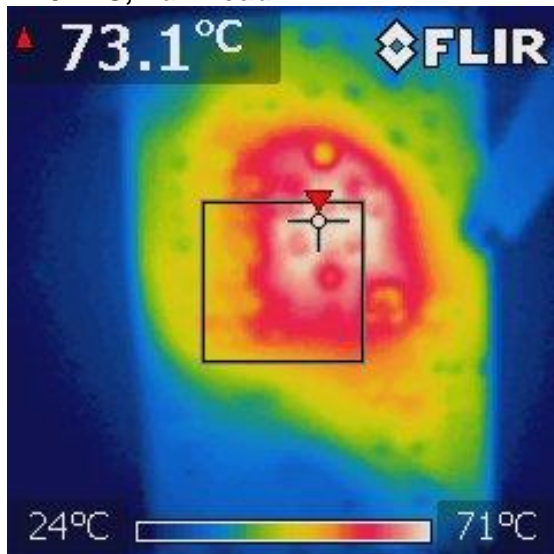

TOP

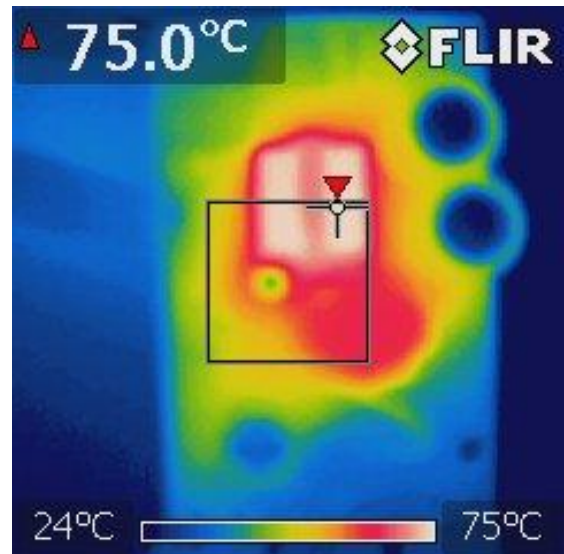

BOTTOM

EVB Test Results

Performance waveforms are tested on the evaluation board.

$V_{IN}=85\text{--}420\text{VAC}/60\text{Hz}$, $V_{OUT1}=13.5\text{V}$, $I_{OUT1}=300\text{mA}$, $V_{OUT2}=8\text{V}$, $I_{OUT2}=50\text{mA}$, $V_{OUT3}=8\text{V}$, $I_{OUT3}=50\text{mA}$, $T_A=25^\circ\text{C}$, unless otherwise noted.

MOSFET Voltage Stress

$V_{IN}=420\text{VAC}$, Full Load

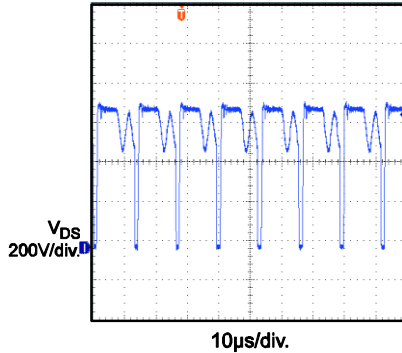

Output1 Diode Voltage Stress

$V_{in}=420\text{VAC}$, Full Load

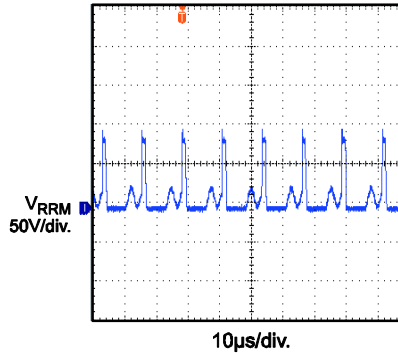

Output2 Diode Voltage Stress

$V_{IN}=420\text{VAC}$, Full Load

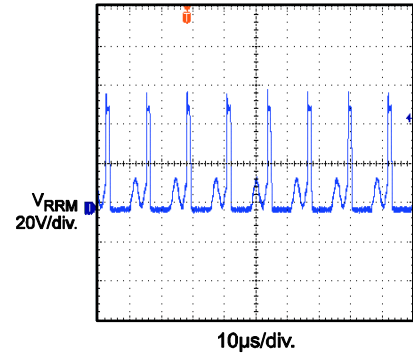

Output Ripple

$V_{IN}=230\text{VAC}$, Full Load

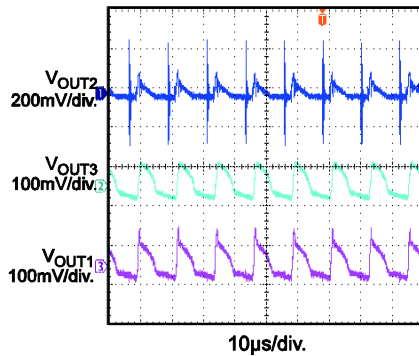

Output Ripple

$V_{IN}=300\text{VAC}$, Full Load

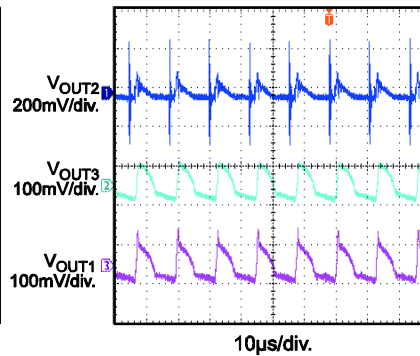

Soft Start

$V_{IN}=230\text{VAC}$, Full Load

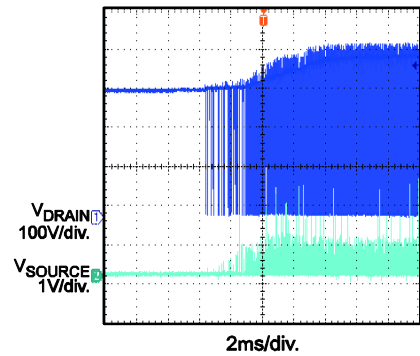

Soft Start

$V_{IN}=300\text{VAC}$, Full Load

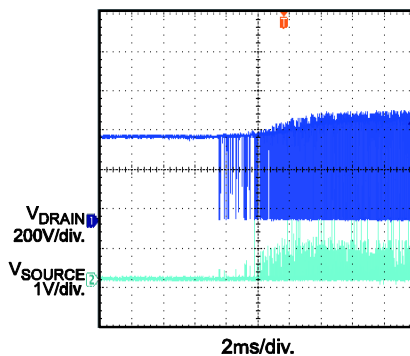

Turn on Delay

$V_{IN}=230\text{VAC}$, Full Load

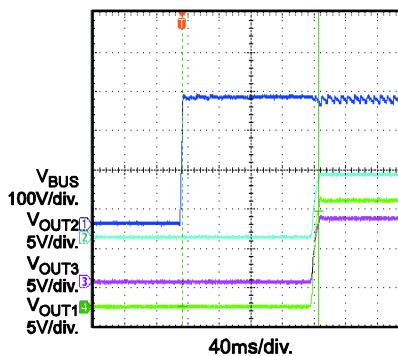

Turn on Delay

$V_{IN}=230\text{VAC}$, No Load

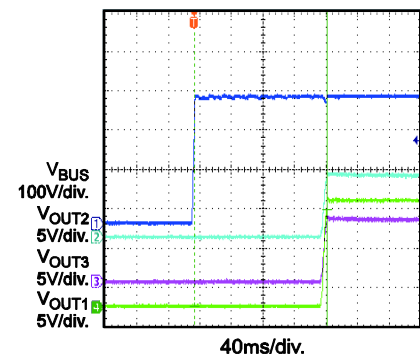

EVB Test Results

Performance waveforms are tested on the evaluation board.

$V_{IN}=85\text{--}420\text{VAC}/60\text{Hz}$, $V_{OUT1}=13.5\text{V}$, $I_{OUT1}=300\text{mA}$, $V_{OUT2}=8\text{V}$, $I_{OUT2}=50\text{mA}$, $V_{OUT3}=8\text{V}$, $I_{OUT3}=50\text{mA}$, $T_A=25^\circ\text{C}$, unless otherwise noted.

Turn on Delay

$V_{IN}=300\text{VAC}$, Full Load

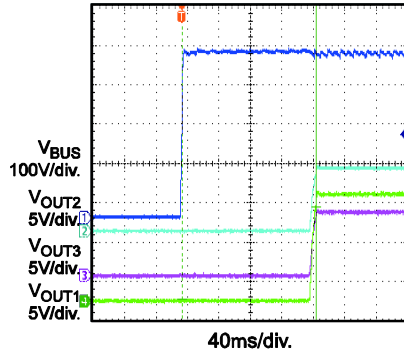

Turn on Delay

$V_{IN}=300\text{VAC}$, No Load

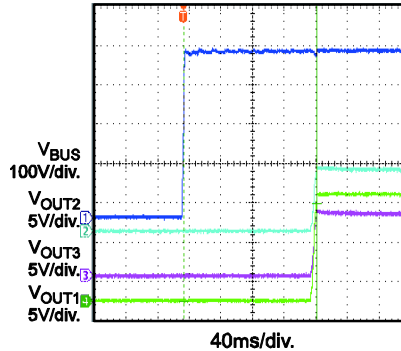

Output1 Load Transient

$V_{IN}=230\text{VAC}$, Half Load to Full Load

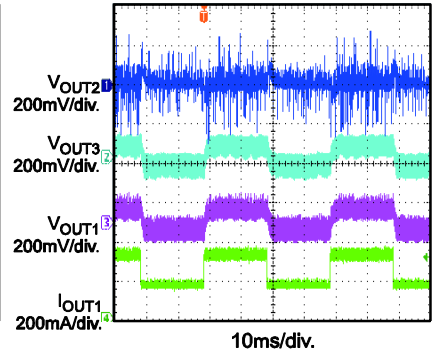

Output1 Load Transient

$V_{IN}=300\text{VAC}$, Half Load to Full Load

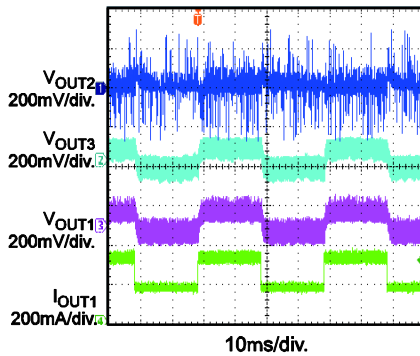

Output3 Load Transient

$V_{IN}=230\text{VAC}$, Half Load to Full Load

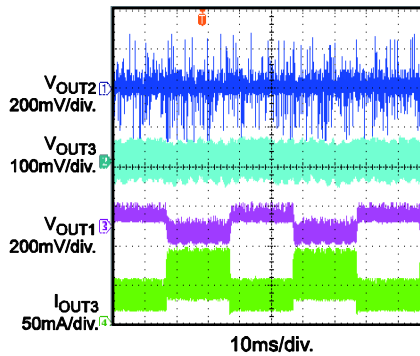

Output3 Load Transient

$V_{IN}=300\text{VAC}$, Half Load to Full Load

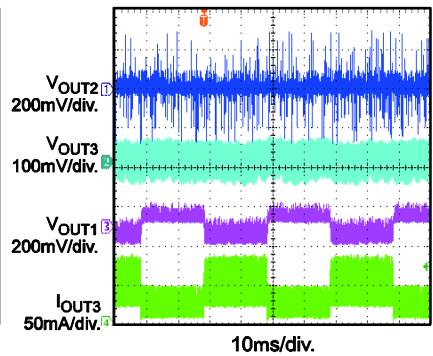

SCP Entry

$V_{IN}=230\text{VAC}$, Full Load

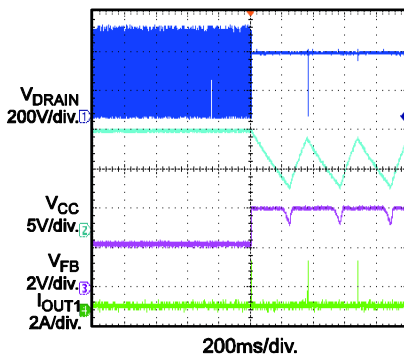

SCP Recovery

$V_{IN}=230\text{VAC}$, Full Load

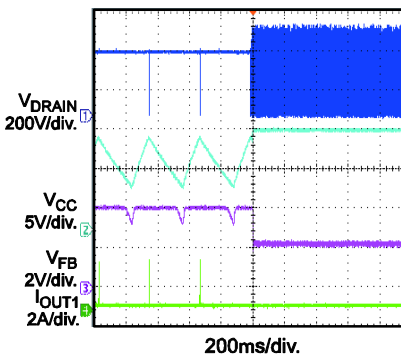

SCP Entry

$V_{IN}=300\text{VAC}$, Full Load

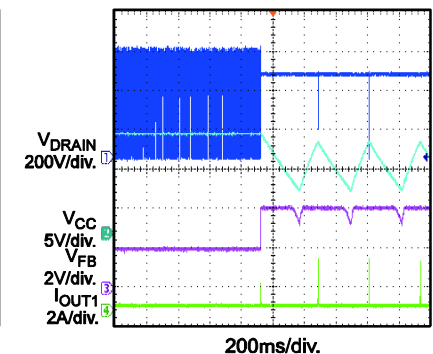

EVB Test Results

Performance waveforms are tested on the evaluation board.

$V_{IN}=85\text{--}420\text{VAC}/60\text{Hz}$, $V_{OUT1}=13.5\text{V}$, $I_{OUT1}=300\text{mA}$, $V_{OUT2}=8\text{V}$, $I_{OUT2}=50\text{mA}$, $V_{OUT3}=8\text{V}$, $I_{OUT3}=50\text{mA}$, $T_A=25^\circ\text{C}$, unless otherwise noted.

SCP Recovery

$V_{IN}=300\text{VAC}$, Full Load

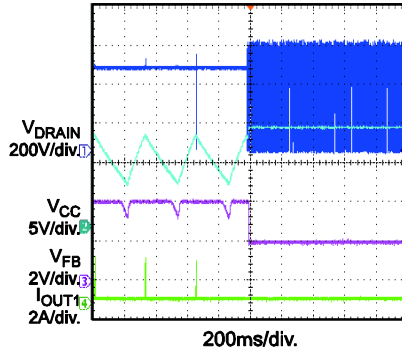

OLP Entry

$V_{IN}=230\text{VAC}$

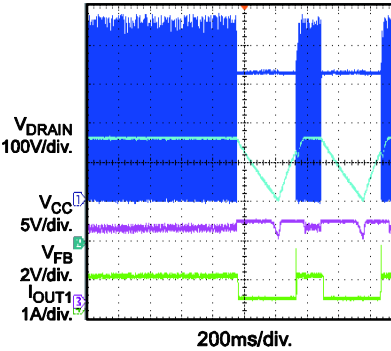

OLP Recovery

$V_{IN}=230\text{VAC}$

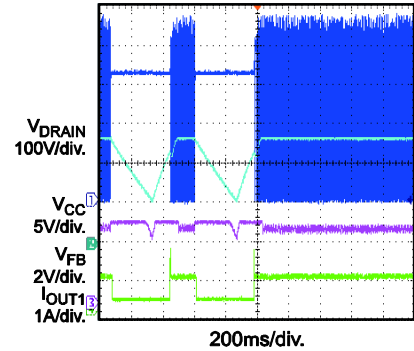

OLP Entry

$V_{IN}=300\text{VAC}$

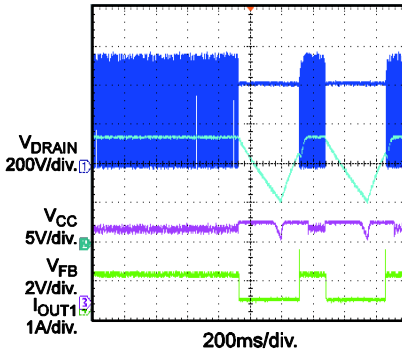

OLP Recovery

$V_{IN}=300\text{VAC}$

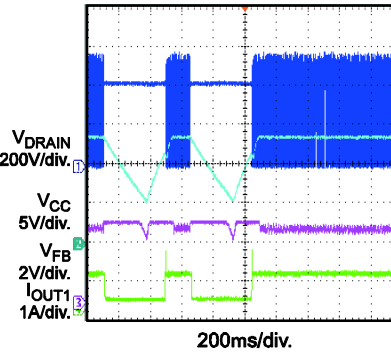

OVP

$V_{IN}=230\text{VAC}$, Full load

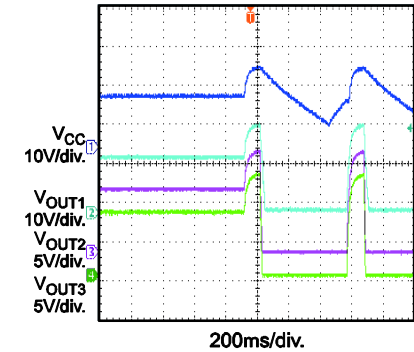

OVP

$V_{IN}=300\text{VAC}$, Full Load

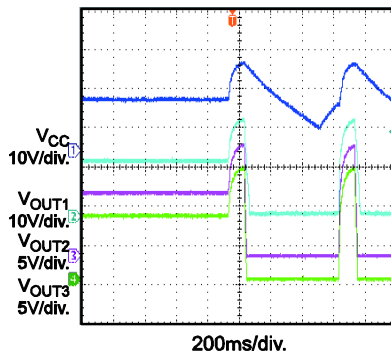

Pro Protection Entry

$V_{IN}=300\text{VAC}$, 400VAC protection Full Load

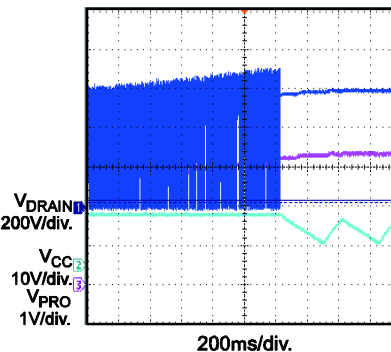

Pro Protection Recovery

$V_{IN}=300\text{VAC}$, 360VAC recovery Full Load

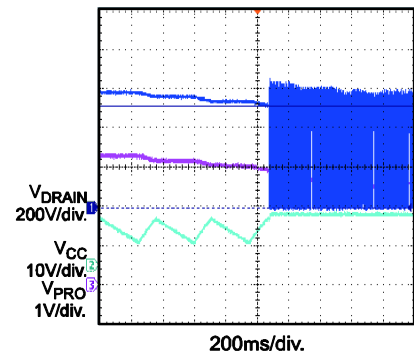

QUICK START GUIDE

1. Preset Power Supply to $85\text{VAC} \leq V_{\text{IN}} \leq 420\text{VAC}$.
2. Turn Power Supply off.
3. Connect the Line and Neutral terminals of the power supply output to L and N port. For three-wire input application, make OUTPUT GND connected to Earth.
4. Connect Load to:
 - a. Positive (+): VOUT
 - b. Negative (-): GND
5. Turn Power Supply on after making connections.

Contact Information

To request this evaluation board, please refer to your local sales offices which can be found from:

<http://www.monolithicpower.com/Company/Contact-Us>

Disclaimer

Monolithic Power Systems (MPS) reserves the right to make changes to its products and to discontinue products without notice. The applications information, schematic diagrams, and other reference information included herein is provided as a design aid only and are therefore provided as-is. MPS makes no warranties with respect to this information and disclaims any implied warranties of merchantability or non-infringement of third-party intellectual property rights.

MPS cannot assume responsibility for use of any circuitry other than circuitry entirely embodied in a MPS product. No circuit patent licenses are implied.

Certain applications using semiconductor products may involve potential risks of death, personal injury, or severe property or environmental damage (“Critical Applications”).

MPS PRODUCTS ARE NOT DESIGNED, INTENDED, AUTHORIZED, OR WARRANTED TO BE SUITABLE FOR USE IN LIFE-SUPPORT APPLICATIONS, DEVICES OR SYSTEMS, OR OTHER CRITICALAPPLICATIONS.

Inclusion of MPS products in critical applications is understood to be fully at the risk of the customer. Questions concerning potential risk applications should be directed to MPS.

MPS semiconductors are typically used in power supplies in which high voltages are present during operation. High voltage safety precautions should be observed in design and operation to minimize the chance of injury.

NOTICE: The information in this document is subject to change without notice. Please contact MPS for current specifications. Users should warrant and guarantee that third party Intellectual Property rights are not infringed upon when integrating MPS products into any application. MPS will not assume any legal responsibility for any said applications.