



MEZS7-1ALinearCharger

1A, Standalone, Linear, Li-Ion Battery Charger with Thermal Regulation Solution Module

DESCRIPTION

The MEZS7-1ALinearCharger is a complete solution module using the MP26029, a highly integrated, single-cell Li-ion/Li-polymer battery charger with thermal regulation. It uses the input from either an AC adapter or USB port to charge the battery. The charger features pre-charge, high-accuracy constant current (CC, up to 1A) and constant voltage (CV) regulation, charge termination, and auto-recharge.

ELECTRICAL SPECIFICATIONS

Parameter	Symbol	Value	Units
Input voltage	V_{IN}	4.35 to 5.50	V
Charge current	I_{CC}	30 to 1000	mA
Battery voltage	V_{BATT}	4.2	V

FEATURES

- Fully Autonomous Charger for Single-Cell Li-ion/Polymer Batteries
- Configurable 30mA to 1A Charge Current
- 0.5% Charging Voltage Accuracy
- 13V Maximum Voltage for the Input Source
- Fully Integrated Power Switches and No External Blocking Diode Required
- Built-In Robust Charging Protection, including Battery Temperature Monitor and Safety Timer
- On-Chip Thermal Limiting Regulation

APPLICATIONS

- Smart Handheld Devices
- Digital Cameras
- Bluetooth
- Toys

All MPS parts are lead-free, halogen-free, and adhere to the RoHS directive. For MPS green status, please visit the MPS website under Quality Assurance. "MPS", the MPS logo, and "Simple, Easy Solutions" are trademarks of Monolithic Power Systems, Inc. or its subsidiaries.

MEZS7-1ALINEARCHARGER SOLUTION MODULE

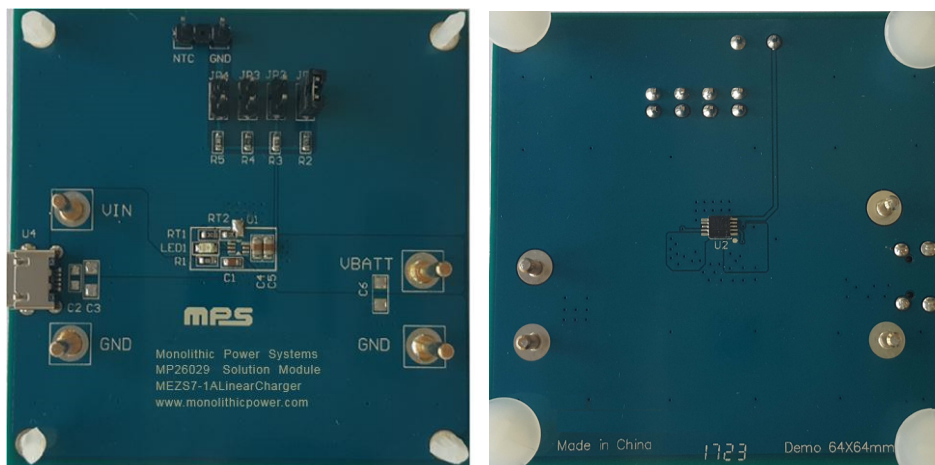

(LxWxH) 6.35cmx6.35cmx0.16cm

Board Number	MPS IC Number
MEZS7-1ALinearCharger	MP26029GQ-xxxx* (1)

Note:

1) "xxxx" is the register setting option. The factory default is "0000". For customer options, contact an MPS FAE to obtain an "xxxx" value.

QUICK START GUIDE

This board is designed for the MP26029, a standalone, 1A, linear Li-ion battery charger with thermal regulation. The BATT output voltage on this board is preset to 4.2V for single-cell Li-ion batteries. The board layout accommodates most commonly used capacitors.

The LED pin is a fault and charging indicator. Table 1 shows the status of the STAT pin while the device is in different charging states.

Table 1: STAT Pin Statuses

Charging State	STAT
Charging	Low
Charging complete	High
Charging suspended due to a fault	Blinking at 1Hz

Table 2 shows how to set the charge current (I_{CC}) using the jumpers (JP1, JP2, JP3 and JP4).

Table 2: Setting the Charge Current

JP	JP1	JP2	JP3	JP4
I_{CC}	1006mA	484mA	114mA	32mA

1. Attach the ends of the battery to:
 - a. Positive (+): BATT
 - b. Negative (-): GND
2. Attach the input voltage ($V_{IN} = 5V$) to the VIN pin, then attach input ground to the GND pin.

SOLUTION MODULE SCHEMATIC

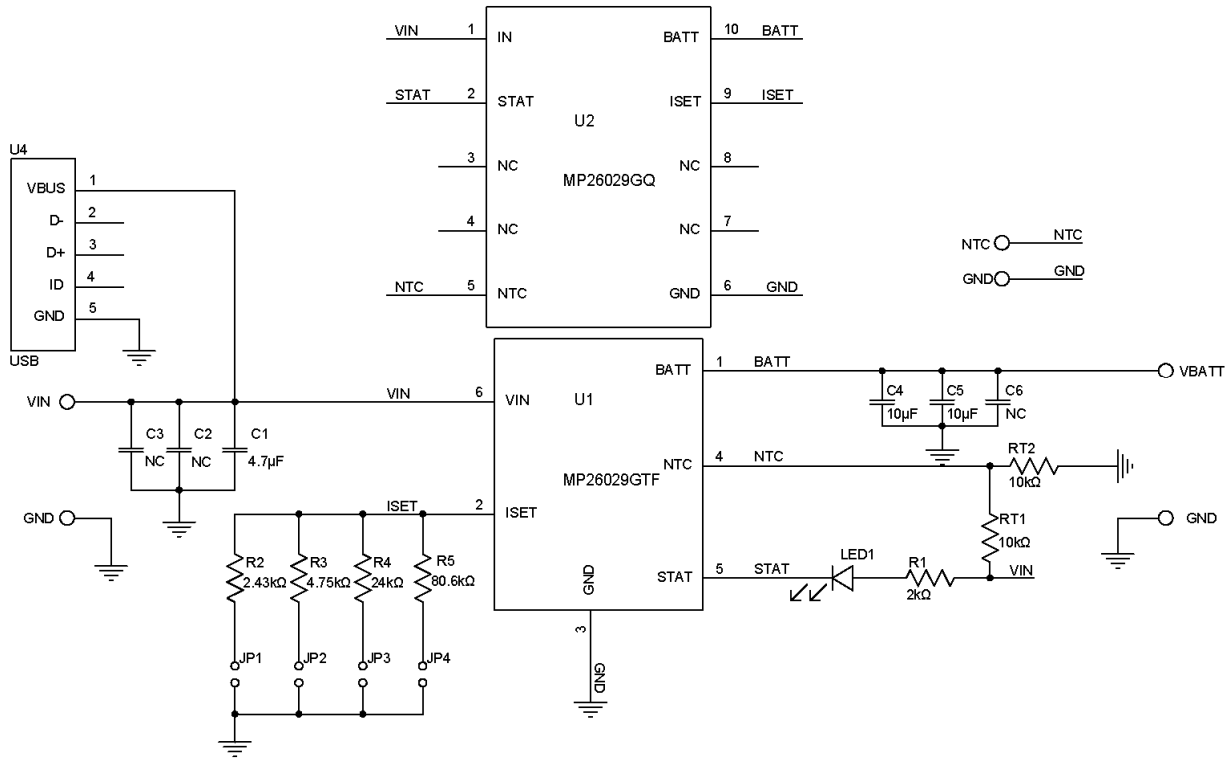
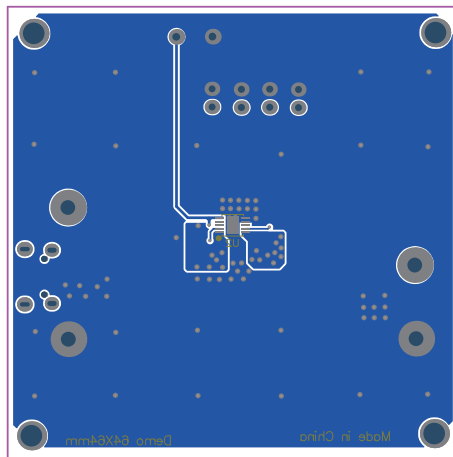
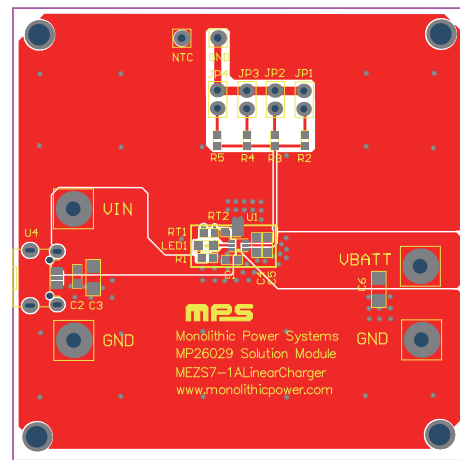
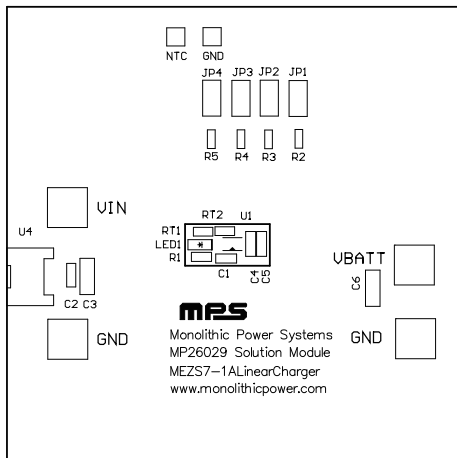

Figure 1: Solution Module Schematic

MEZS7-1ALINEARCHARGER BILL OF MATERIALS

Qty	Ref	Value	Description	Package	Manufacturer	Manufacturer P/N
1	C1	4.7 μ F	Ceramic capacitor, 25V, X6S, 0603	0603	muRata	GRM188C81E475KE11D
1	C2	NC	Ceramic capacitor, 25V, X7R, 0805	0805	muRata	GRM21BR71E225KA73L
2	C3, C6	NC	Ceramic capacitor, 25V, X7R, 1206	1206	muRata	GRM31CR71E475KA88L
2	C4, C5	10 μ F	Ceramic capacitor, 10V, X7R, 0805	0805	muRata	GRM21BR71A106ME51L
1	LED1		Red LED	0805	Bright LED	BL-HUF35A-TRB
1	R1	2k Ω	Film resistor, 1%	0603	Yageo	RC0603FR-072KL
1	R2	3.01k Ω	Film resistor, 1%	0603	Yageo	RC0603FR-073K01L
1	R3	6.04k Ω	Film resistor, 1%	0603	Yageo	RC0603FR-076K04L
1	R4	24k Ω	Film resistor, 1%	0603	Yageo	RC0603FR-0724KL
1	R5	80.6k Ω	Film resistor, 1%	0603	Yageo	RC0603FR-0780K6L
2	RT1, RT2	10k Ω	Film resistor, 1%	0603	Yageo	RC0603FR-0710KL
1	U1	NC	1-cell linear charger	SOT563	MPS	MP26029GTF-xxxx
1	U2		1-cell linear charger	QFN-10 (3mmx3mm)	MPS	MP26029GQ-xxxx
1	U4		Micro-B USB receptacle	DIP	Würth	629105150521

PCB LAYOUT



Notice: The information in this document is subject to change without notice. Please contact MPS for current specifications. Users should warrant and guarantee that third-party Intellectual Property rights are not infringed upon when integrating MPS products into any application. MPS will not assume any legal responsibility for any said applications.