

DESCRIPTION

The EV3360DG-00A is an evaluation board for the MP3360, a fast, highly efficient and precision high voltage photo-flash charger for xenon flash applications.

The peak current is 1.5A to ensure fast charging time. 0.5Ω internal power switch minimizes the conduction loss. 60V maximum SW operating voltage lowers transformer turns ratio and switching loss associated with the primary leakage inductance.

The board offers charge-ready indicator, flash mode.

ELECTRICAL SPECIFICATIONS

Parameter	Symbol	Value	Units
Input Voltage	V_{IN}	2.8-6	V
Supply Voltage	V_{CC}	2.8-6	V
Peak charge current	I_{peak}	1.5	A
Charge Voltage	V_o	300	V

FEATURES

- 1.5A Peak Charge Current
- 2.5% Charge Accuracy
- Charge-ready indicator
- Microcontroller controlled on/off, flash mode
- Integrated IGBT Driver

APPLICATIONS

- Digital Still Cameras
- Optical Film Cameras

"MPS" and "The Future of Analog IC Technology" are Registered Trademarks of Monolithic Power Systems, Inc.

EV3360DG-00A EVALUATION BOARD



(L x W x H) 2.7" X 3.6" X 1.1"

Board Number	MPS IC Number
EV3360DG-00A	MP3360DG

Efficiency vs V_{out}

$I_{SET} = 1.5A$ with 1:8 transformer

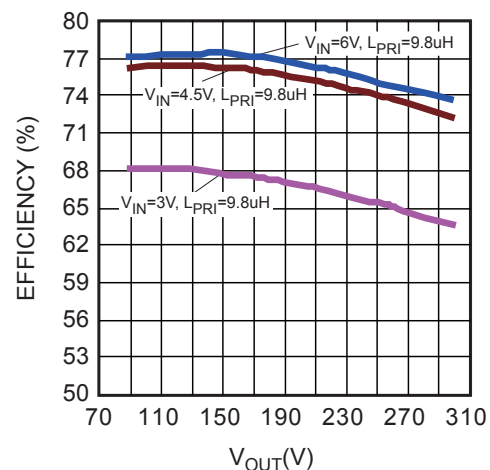

EVALUATION BOARD SCHEMATIC

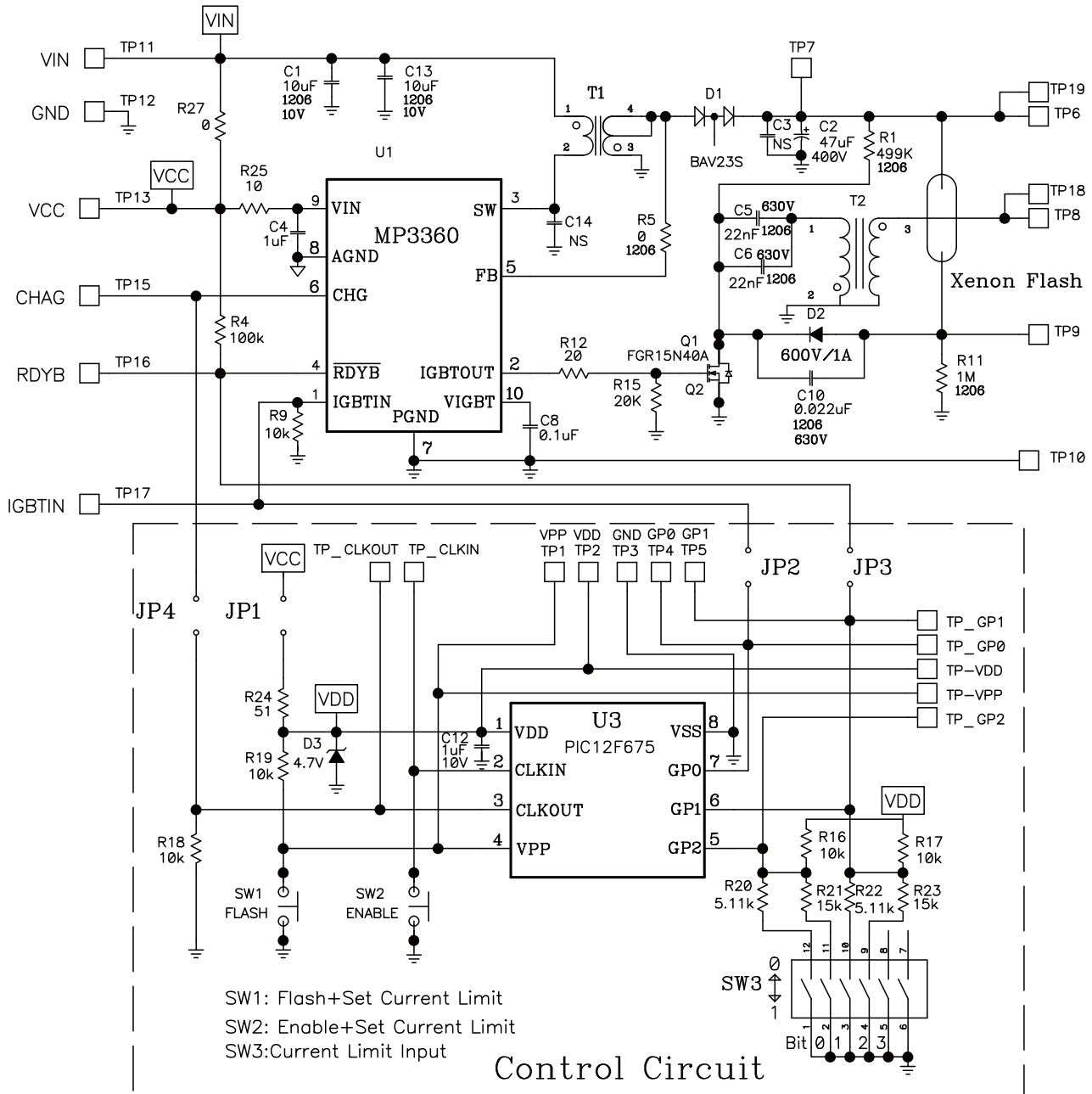

EV3360DG-00A BILL OF MATERIALS

Qty	Ref	Value	Description	Package	Manufacturer	Manufacturer P/N
2	C1,C13	10uF	Ceramic Cap. 10V, X7R	1206	MuRata	GRM31CR71A106K
1	C2	47uF	El. Al. Cap. 400V, 20%	D16xL25	Panasonic	EEUED2G470
1	C4	1uF	Ceramic Cap. 10V, X7R	0603	MuRata	GRM188R71A105K
3	C5,C6,C10	22nF	Ceramic Cap. 630V, X7R	1206	TDK	C3216JB2J223K
0	C3	NS		1206		
0	C14	NS		0805		
1	C8	0.1uF	Ceramic Cap. 10V, X7R	0603	MuRata	GRM188R71A104K
1	R1	499K	Film Resistor, 1%	1206	Yageo	9C12063A4993FKHFT
1	R4	100k	Film Resistor, 1%	0603	Yageo	9C06031A1003FKHFT
1	R5	0Ω	Film Resistor, 5%	1206	Yageo	9C12063A0R00JLHFT
1	R9	10k	Film Resistor, 1%	0603	Yageo	9C06031A1002FKHFT
1	R11	1M	Film Resistor, 1%	1206	Yageo	9C12063A1004FKHFT
1	R12	20Ω	Film Resistor, 1%	0603	Yageo	9C06031A20R0FKHFT
1	R15	20k	Film Resistor, 1%	0603	Yageo	9C06031A2002FKHFT
1	R25	10Ω	Film Resistor, 5%	0603	Yageo	9C06031A10R0JLHFT
1	R27	0Ω	Film Resistor 5%	0603	Yageo	9C06031A0R00JLHFT
1	D1	250V/400mA	Switching Diode	SOT-23	DIODES	BAV23S
1	D2	1A	Diode Switching 600V	SMA	VISHAY	RS1J-E3/61TGICT
1	Q1	400V	Flash N-Ch Logic IGBT	TSSOP-8	TOSHIBA	GT8G133
0	Q2	NS	Flash N-Ch Logic IGBT	SO-8		
1	T1	T-19-060	Transformer	SM	TOKYO Coil	T-19-060
1	T2	BO-02	Transformer	SM	TOKYO Coil	BO-02
	or	ZS1092	Transformer	SM	Triger Coil	ZS1092/0.047
0	TP6~TP10, TP18,TP19	NS				
1	VIN- IGBTIN		8-pin header, 2mm	2MM spacing	SULLINS Elec.	PRPN081PAEN-RC
1	Flash	NS	Xenon Flash			
1	U1	MP3360DG	Photo Flash Charger	QFN10 2X2mm	MPS	MP3360DG

EV3360DG-00A CONTROL CIRCUIT BILL OF MATERIALS

Qty	Ref	Value	Description	Package	Manufacturer	Manufacturer P/N
1	U3	EEPROM	Data EEPROM Memory	SO8	MicroChip	PIC12F675
1	C12	1uF	Ceramic Cap. 10V, X7R	0805	MuRata	GRM21BR71A105K
4	R16,R17, R18,R19	10k	Film Resistor, 1%	0603	Yageo	9C06031A1002FKHFT
2	R20,R22	5.11k	Film Resistor, 1%	0603	Yageo	9C06031A5111FKHFT
2	R21,R23	15k	Film Resistor, 1%	0603	Yageo	9C06031A1502FKHFT
1	R24	51	Film Resistor, 1%	0603	Yageo	9C06031A51R0FKHFT
1	D3	4.7V	Zaener Diode 0.5W	SOD123	DIODES	BZT52C4V7
2	SW1,SW2	Switch	Push Switching button	SM 4x10mm	Digi-Key	P8002SCT-ND
1	SW3	6 pos	DIP Switching	DIP6	Digi-Key	CKN1290-ND
4	JP1~JP4	2-pin	2-pin Header, 2.54mm	2.54mm	Sullins	PTC02SAAN
3	Jumper1,2,4	2-pin	Short Jumper, 2.54mm	2.54mm	Sullins	STC02SYAN
0	Jumper 3	NS				
1	TP1~TP5		5-pin Header, 2.54mm	2.54mm	Sullins	PTC05SAAN

PRINTED CIRCUIT BOARD LAYOUT

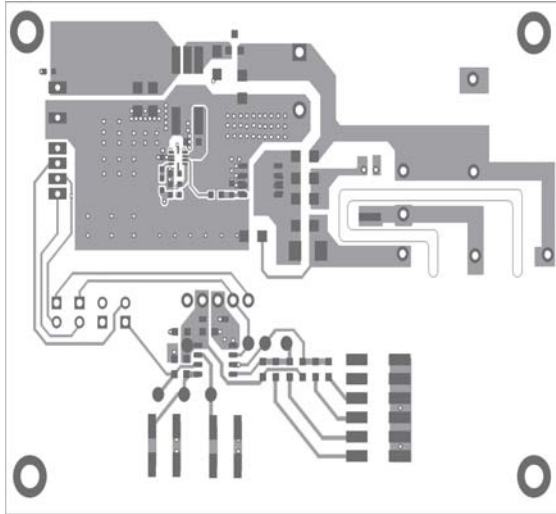

Figure 1—Top Layer

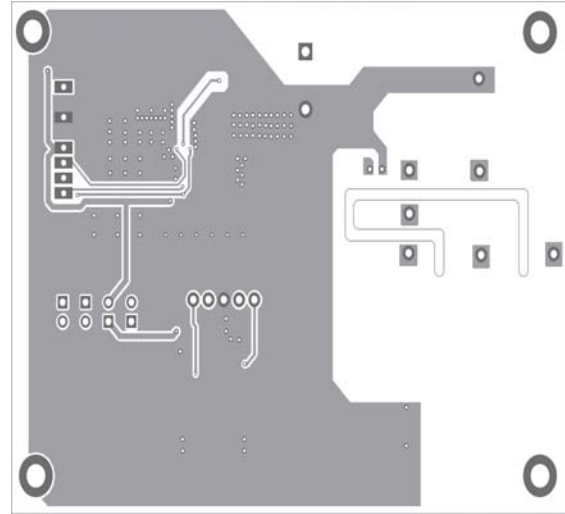

Figure 2—Bottom Layer

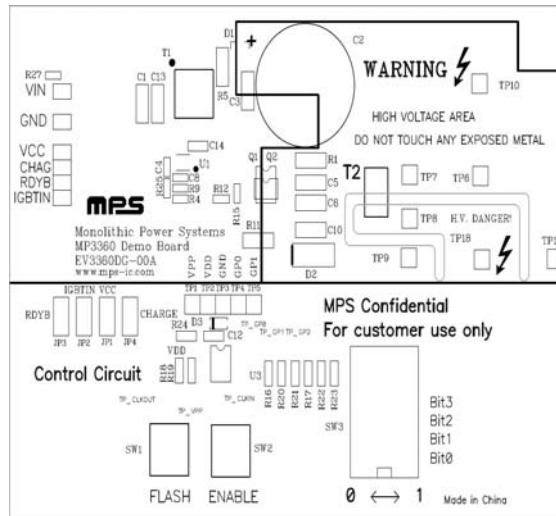

Figure 3—Top Silk Layer

QUICK START GUIDE

1. Solder Q1, trigger coil-T2 and Xenon Flash tube the board if they are not populated.
2. Turn off the power supply.
3. Attach the positive terminal of the power supply (3V - 6V) to the VIN.
4. Attach the negative terminal of the power supply to GND pin.
5. Turn on the power supply.
6. Press “FLASH”-SW1 once to trigger the flash sequencing. First, the microcontroller will enable charge for certain time and then trigger the IGBT to light up the flash tube
7. “ENABLE”-SW2 serves only as a toggle SW to start/stop the charge, no flash will be triggered.
8. SW2 works with SW3 to set the current limit
 - a. use SW3 to program the current limit (see table for setting Bits 0-3)

Binary code	Current limit(A)
0000	0.40
0001	0.45
0010	0.50
0011	0.55
0100	0.60
0101	0.65
0110	0.70
0111	0.75
1000	0.80
1001	0.90
1010	1.00
1011	1.10
1100	1.20
1101	1.30
1110	1.40
1111	1.50

- b. press SW2 to Enable the part and set the current limit

NOTICE: The information in this document is subject to change without notice. Please contact MPS for current specifications. Users should warrant and guarantee that third party Intellectual Property rights are not infringed upon when integrating MPS products into any application. MPS will not assume any legal responsibility for any said applications.