



mEZ Product Options:

1. Ready-to-Use products
 2. Do-It-Yourself.
- Manufacture assistance is provided

FEATURES

- 4.5V to 17V Wide Operating Input
- 10A Load Current
- 1V Output Voltage
- Over-Current Protection
- Over-Temperature Protection
- Open Design Files and BOM
- I²C Programmable

ORDERING INFORMATION

Part Number	Input Voltage (V)	Output Voltage (V)	Output Current (A)
MEZD71210A-A	4.5 - 17	1.0	10

mEZD712xx FAMILY PRODUCTS

Part Number	Input Voltage (V)	Output Voltage (V)	Output Current (A)
mEZD71201A-X	4.5 - 24	1, 1.2, 1.5, 1.8, 2.5, 3.3, 5	1
mEZD71202A-X	4.5 - 24	1, 1.2, 1.5, 1.8, 2.5, 3.3, 5	2
mEZD71203A-X	5 - 16	1, 1.2, 1.5, 1.8, 2.5, 3.3	3
mEZD71210A-A	4.5 - 17	1.0	10

ELECTRICAL CHARACTERISTICS

Input Voltage Range	V _{IN} Continuous	4.5 to 17V
Output Voltage Set Accuracy		±2.4% (Typ.)
Output Voltage Ripple	V _{IN} = 12V, V _{OUT} = 1V, Full Load	15mV
Line Regulation	V _{IN} from MIN to MAX, V _{OUT} = 1V	±1% (Typ.)
Load Regulation	I _{OUT} from MIN to MAX, V _{OUT} = 1V	±1% (Typ.)
Switching Frequency	Typical Switching Frequency	500kHz
Short-Circuit Protection	Short Output to Ground	Hiccup Mode
Operating Temperature Range		-40 to 85°C
Over-Temperature Protection	OTP	160°C
Rise Time	V _{OUT} from 0% to 90%	1.6ms (Typ.)
Calculated MTBF	MIL-HDBK-217F	4185x10 ³ hrs

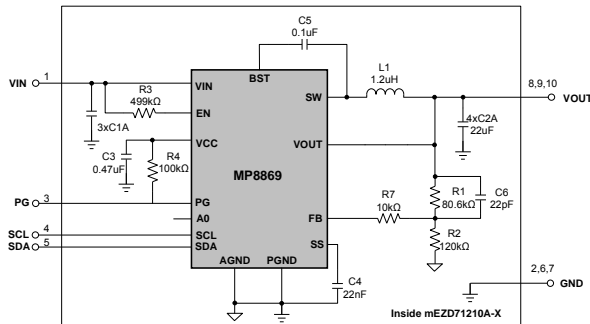

Block Diagram

Efficiency vs. Load Current
V_{IN} = 4.5V, 12V, and 17V, V_{OUT} = 1V

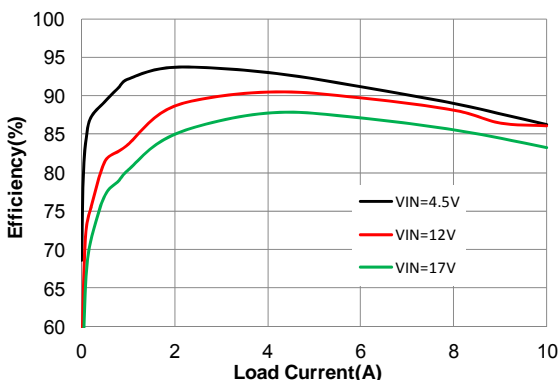

NOTE: All electrical characteristics are tested under 25°C ambient temperature. V_{IN} = 12V unless otherwise noted.

DO-IT-YOURSELF SCHEMATIC

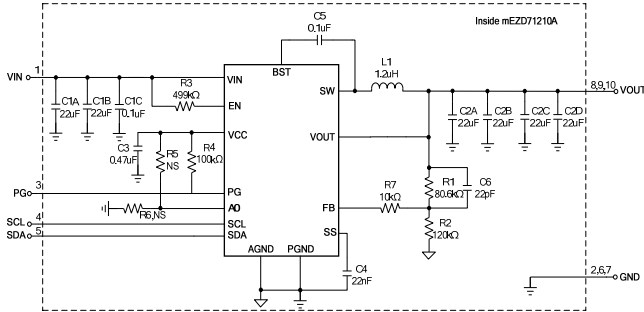

POWER DERATING

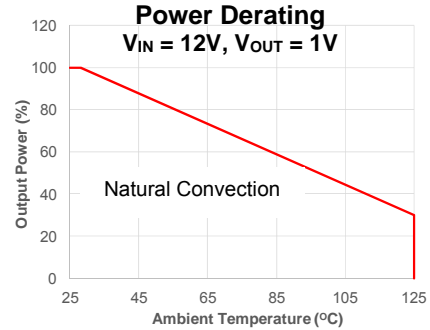

BILL OF MATERIALS

Item	Qty	RefDes	Value	Description	Package	Manufacturer	Manufacturer P/N
1	6	C1A, C1B, C2A, C2B, C2C, C2D	22μF	Ceramic Cap, 25V, X5R	805	muRata	GRM21BR61E226ME44L
2	1	C1C	0.1μF	Ceramic Cap, 25V, X7R	603	WE	885012206071
3	1	C3	0.47μF	Ceramic Cap, 10V, X7R	402	muRata	GRM155R71A474KE15
4	1	C4	22nF	Ceramic Cap, 16V, X7R	402	WE	885012205033
5	1	C5	0.1μF	Ceramic Cap, 16V, X7R	402	WE	885012205037
6	1	C6	22pF	Ceramic Cap, 50V, C0G	402	WE	885012005057
7	1	R1	80.6kΩ	Film Res, 0.5%	402	Yageo	RC0402DR-0780K6L
8	1	R2	120kΩ	Film Res, 0.5%	402	Yageo	RC0402DR-07120KL
9	1	R3	499kΩ	Film Res, 0.5%	402	Yageo	RC0402DR-07499KL
10	1	R4	100kΩ	Film Res, 0.5%	402	Yageo	RC0402DR-07100KL
11	0	R5, R6	NS				
12	1	R7	10kΩ	Film Res, 0.5%	402	Yageo	RC0402DR-0710KL
13	1	L1*	1.2μH	DCR = 1.8mΩ, Isat = 20A	SMD, 10mmx10mm	WE	744325120
14	1	U1	MP8869	Step-Down Converter with I ² C Interface	QFN-16 (3mmx4mm)	MPS	MP8869GLE
15	1	JP1		10-Pin Connector		WE	61301011021

* Or equivalent

PRODUCT PACKAGE AND DIMENSIONS

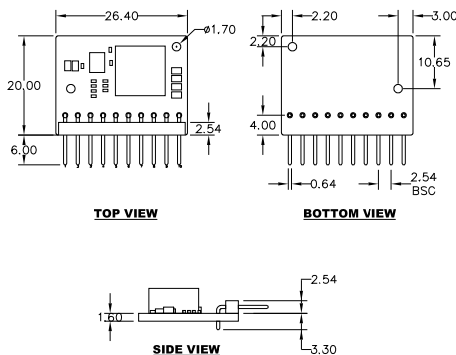

Pin	Designation	Function
1	VIN	Input Voltage
2	GND	Power Ground
3	PG	Power Good
4	SCL	I ² C Serial Clock
5	SDA	I ² C Serial Data
6	GND	Power Ground
7	GND	Power Ground
8	VOUT	Output Voltage
9	VOUT	Output Voltage
10	VOUT	Output Voltage

NOTE:

Contact factory for different sizes of the boards (Quantity >2k).

For more information, Gerber files, and PCB layout, please contact mEZsupport@monolithicpower.com