

DESCRIPTION

The MP1921B is a high-frequency 100V half-bridge N-channel power MOSFET driver. Its low-side and high-side driver channels are independently controlled and matched, with a time delay of less than 5ns. Under-voltage lockout on both high-side and low-side supplies force their outputs low in case of insufficient supply. The integrated bootstrap diode reduces external component count.

FEATURES

- Drives N-Channel MOSFET Half-Bridge
- 120V V_{BST} Voltage Range
- On-Chip Bootstrap Diode
- Typical 16ns Propagation Delay Time
- Less Than 5ns Gate Drive Matching
- Drives 1nF Load with 12ns/9ns Rise/Fall Times with 12V VDD
- TTL Compatible Input
- Less Than 150 μ A Quiescent Current
- UVLO for Both High Side and Low Side
- In QFN10 (3mmx3mm) Package

APPLICATIONS

- Telecom Half-Bridge Power Supplies
- Avionics DC/DC Converters
- Two-Switch Forward Converters
- Active-Clamp Forward Converters
- DC Motor Drivers

All MPS parts are lead-free, halogen free, and adhere to the RoHS directive. For MPS green status, please visit the MPS website under Quality Assurance. "MPS", the MPS logo, and "Simple, Easy Solutions" are Registered Trademarks of Monolithic Power Systems, Inc. or its subsidiaries.

TYPICAL APPLICATION

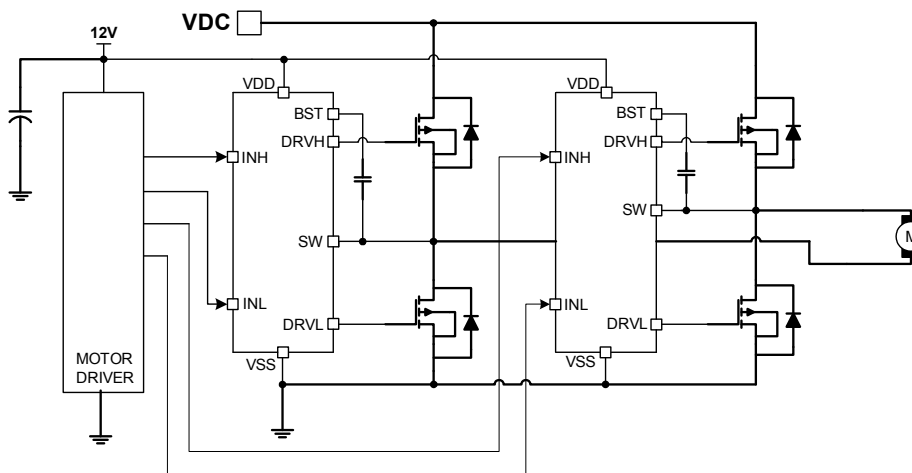

ORDERING INFORMATION

Part Number*	Package	Top Marking
MP1921GQ-B	QFN10 (3mmx3mm)	See Below

* For Tape & Reel, add suffix -Z (e.g. MP1921GQ-B-Z).

TOP MARKING

BLDY
LLL

BLD: Product code of MP1921GQ-B
 Y: Year code
 LLL: Lot number

PACKAGE REFERENCE

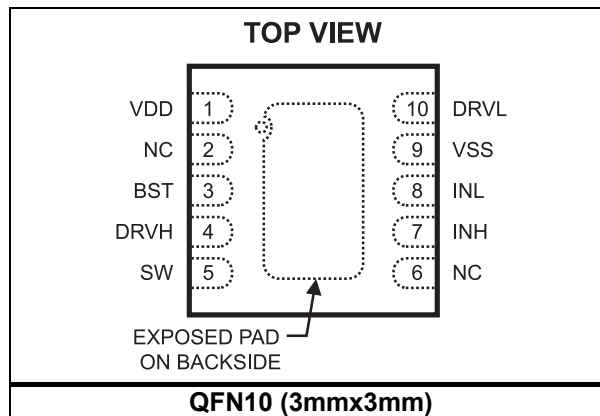

PIN FUNCTIONS

QFN10 (3x3mm)	Name	Description
1	VDD	Supply input. VDD supplies power to all the internal circuitry. A decoupling capacitor to ground must be placed close to VDD to ensure stable and clean supply.
2,6	NC	No connection.
3	BST	Bootstrap. This is the positive power supply for the internal floating high-side MOSFET driver. Connect a bypass capacitor between BST and SW.
4	DRVH	Floating driver output.
5	SW	Switching node.
7	INH	Control signal input for the floating driver.
8	INL	Control signal input for the low-side driver.
9	VSS, Exposed Pad	Chip ground. Connect exposed pad to VSS for proper thermal operation.
10	DRVL	Low-side driver output.

ABSOLUTE MAXIMUM RATINGS ⁽¹⁾

Supply voltage (V_{DD})	-0.3V to +20V
SW voltage (V_{SW})	-5.0V to +105V
BST voltage (V_{BST})	-0.3V to +120V
BST to SW	-0.3V to +18V
DRVH to SW	-0.3V (-5V for <100ns) to (BST-SW) + 0.3V
DRVL to VSS	-0.3V to (V_{DD} + 0.3V)
All other pins	-0.3V to (V_{DD} + 0.3V)
Continuous power dissipation ($T_A = 25^\circ\text{C}$) ⁽²⁾
QFN10 (3mmx3mm) 2.5W
Junction temperature 150°C
Lead temperature 260°C
Storage temperature -65°C to +150°C

Recommended Operating Conditions ⁽³⁾

Supply voltage (V_{DD}) 9.0V to 18V
SW voltage (V_{SW}) -1.0V to +100V
SW slew rate <50V/ns
Operating junction temp (T_J) -40°C to +125°C

Thermal Resistance ⁽⁴⁾	θ_{JA}	θ_{JC}
QFN10 (3mmx3mm) 50 12 ... °C/W

Notes:

- 1) Exceeding these ratings may damage the device.
- 2) The maximum allowable power dissipation is a function of the maximum junction temperature $T_J(\text{MAX})$, the junction-to-ambient thermal resistance θ_{JA} , and the ambient temperature T_A . The maximum allowable continuous power dissipation at any ambient temperature is calculated by $P_D(\text{MAX}) = (T_J(\text{MAX}) - T_A) / \theta_{JA}$. Exceeding the maximum allowable power dissipation will cause excessive die temperature, and the regulator will go into thermal shutdown. Internal thermal shutdown circuitry protects the device from permanent damage.
- 3) The device is not guaranteed to function outside of its operating conditions.
- 4) Measured on JESD51-7, 4-layer PCB.

ELECTRICAL CHARACTERISTICS

$V_{DD} = V_{BST} - V_{SW} = 12V$, $V_{SS} = V_{SW} = 0V$, no load at DRVH and DRVL, $T_A = 25^\circ C$, unless otherwise noted.

Parameter	Symbol	Condition	Min	Typ	Max	Units
Supply Currents						
VDD quiescent current	I_{DDQ}	INL = INH = 0		100	150	μA
VDD operating current	I_{DDO}	$f_{sw} = 500kHz$		2.8	3.5	mA
Floating driver quiescent current	I_{BSTQ}	INL = INH = 0		60	90	μA
Floating driver operating current	I_{BSTO}	$f_{sw} = 500kHz$		2.1	3	mA
Leakage current	I_{LK}	BST = SW = 100V		0.05	1	μA
Inputs						
INL/INH high				2	2.4	V
INL/INH low			1	1.4		V
INL/INH internal pull-down resistance	R_{IN}			185		k Ω
Under-Voltage Protection						
VDD rising threshold	V_{DDR}		7.7	8.1	8.5	V
VDD hysteresis	V_{DDH}			0.5		V
(BST-SW) rising threshold	V_{BSTR}		6.7	7.1	7.5	V
(BST-SW) hysteresis	V_{BSTH}			0.55		V
Bootstrap Diode						
Bootstrap diode VF @ 100 μA	V_{F1}			0.5		V
Bootstrap diode VF @ 100mA	V_{F2}			0.9		V
Bootstrap diode dynamic R	R_D	@ 100mA		2.5		Ω
Low-Side Gate Driver						
Low-level output voltage	V_{OLL}	$I_O = 100mA$		0.15	0.22	V
High-level output voltage to rail	V_{OHL}	$I_O = -100mA$		0.45	0.6	V
Peak pull-up current	I_{OHL}	$V_{DRVL} = 0V, V_{DD} = 12V$		1.5		A
		$V_{DRVL} = 0V, V_{DD} = 16V$		2.5		A
Peak pull-down current	I_{OLL}	$V_{DRVL} = V_{DD} = 12V$		2.5		A
		$V_{DRVL} = V_{DD} = 16V$		3.5		A
Floating Gate Driver						
Low-level output voltage	V_{OLH}	$I_O = 100mA$		0.15	0.22	V
High-level output voltage to rail	V_{OHH}	$I_O = -100mA$		0.45	0.6	V
Peak pull-up current	I_{OHH}	$V_{DRVH} = 0V, V_{DD} = 12V$		1.5		A
		$V_{DRVH} = 0V, V_{DD} = 16V$		2.5		A
Peak pull-down current	I_{OLH}	$V_{DRVH} = V_{DD} = 12V$		2.5		A
		$V_{DRVH} = V_{DD} = 16V$		3.5		A

ELECTRICAL CHARACTERISTICS (continued)

$V_{DD} = V_{BST} - V_{SW} = 12V$, $V_{SS} = V_{SW} = 0V$, no load at DRVH and DRVL, $T_A = 25^\circ C$, unless otherwise noted.

Parameter	Symbol	Condition	Min	Typ	Max	Units
Switching Spec. – Low Side Gate Driver						
Turn-off propagation delay INL falling to DRVL falling	T_{DLFF}			16		ns
Turn-on propagation delay INL rising to DRVL rising	T_{DLRR}			16		
DRVL rise time		$C_L = 1nF$		12		ns
DRVL fall time		$C_L = 1nF$		9		ns
Switching Spec. – Floating Gate Driver						
Turn-off propagation delay INL falling to DRVH falling	T_{DHFF}			16		ns
Turn-on propagation delay INL rising to DRVH rising	T_{DHRR}			16		ns
DRVH rise time		$C_L = 1nF$		12		ns
DRVH fall time		$C_L = 1nF$		9		ns
Switching Spec. – Matching						
Floating driver turn-off to low side drive turn-on	T_{MON}			1	5	ns
Low side driver turn-off to floating driver turn-on	T_{MOFF}			1	5	ns
Minimum input pulse width that changes the output	T_{PW}				50 ⁽⁵⁾	ns
Bootstrap diode turn-on or turn- off time	T_{BS}			10 ⁽⁵⁾		ns

Note:

5) Guaranteed by design.

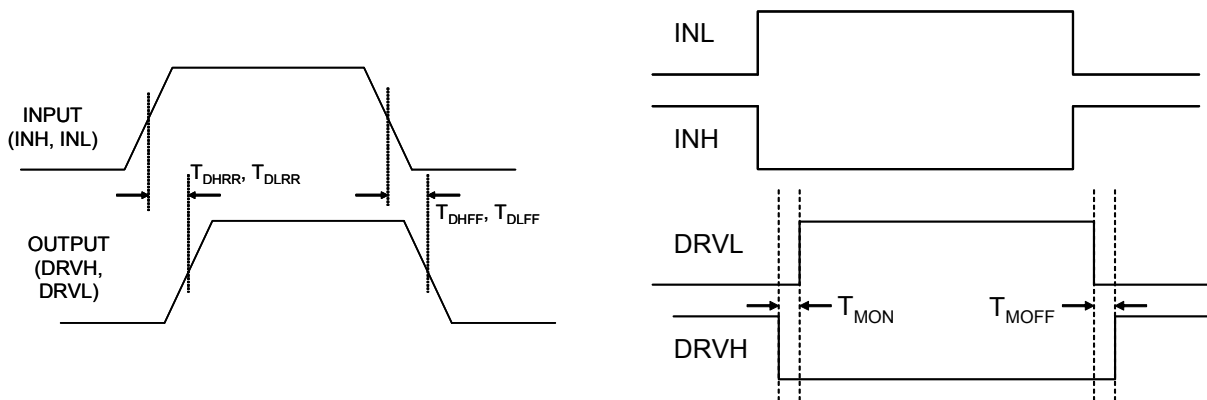
Figure 1: Timing Diagram

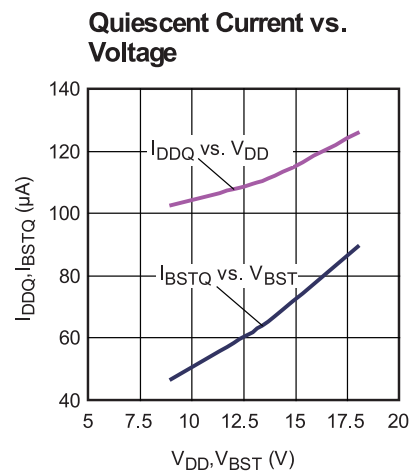
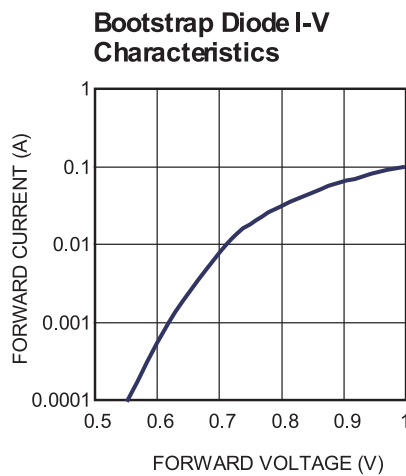
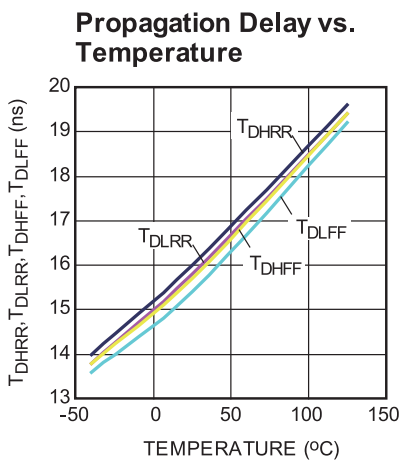
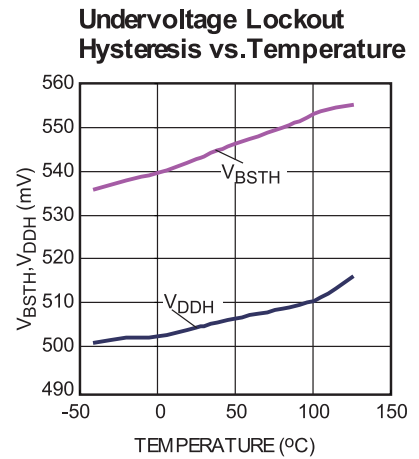
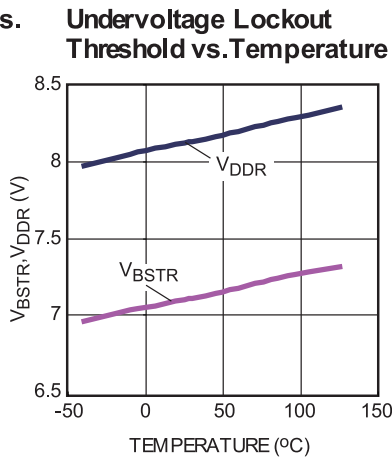
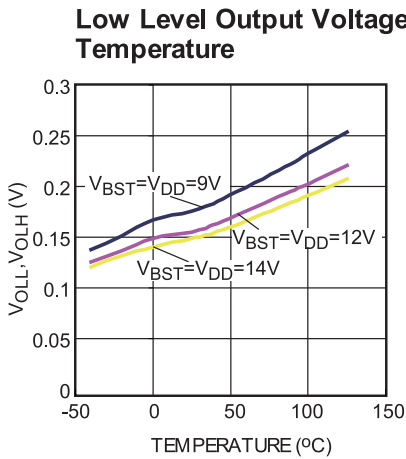
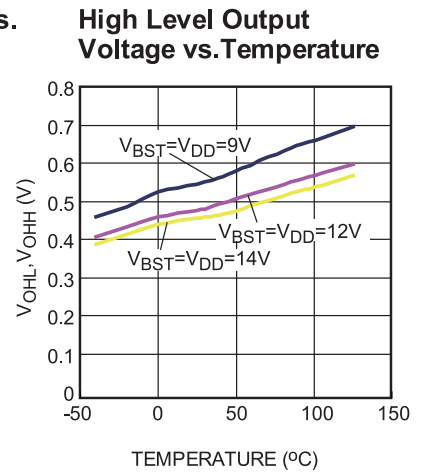
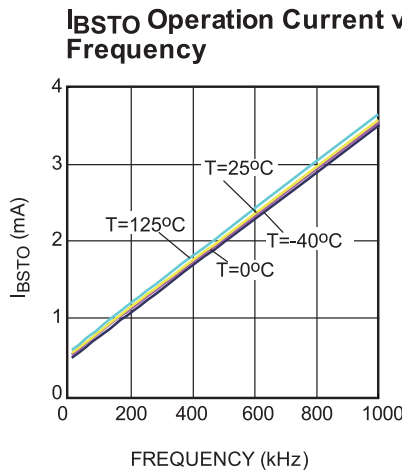
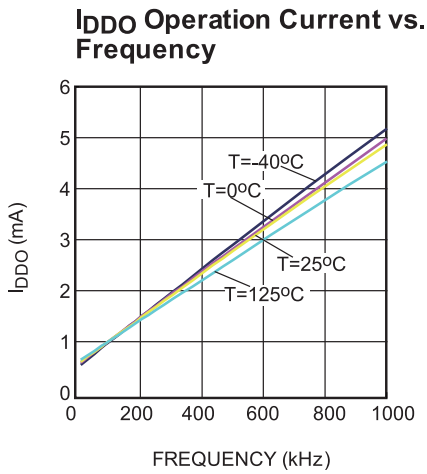
TYPICAL PERFORMANCE CHARACTERISTICS
 $V_{DD} = 12V, V_{SS} = V_{SW} = 0V, T_A = 25^\circ C$, unless otherwise noted.

TYPICAL PERFORMANCE CHARACTERISTICS (continued)
 $V_{DD} = 12V, V_{SS} = V_{SW} = 0V, T_A = 25^\circ C$, unless otherwise noted.

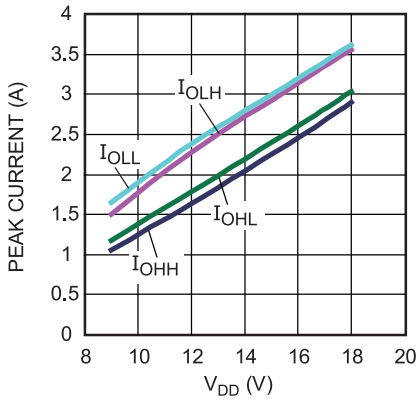
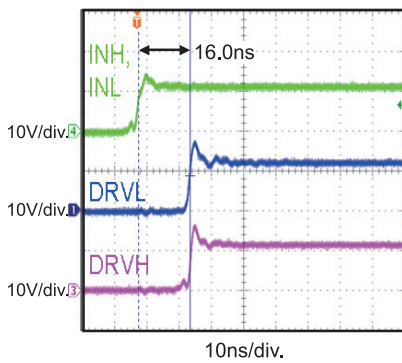
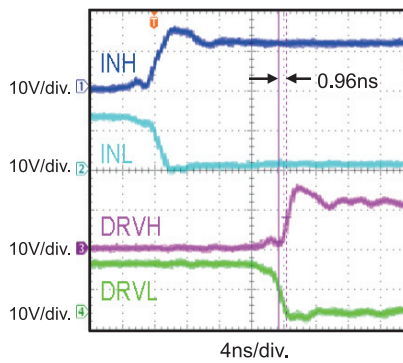
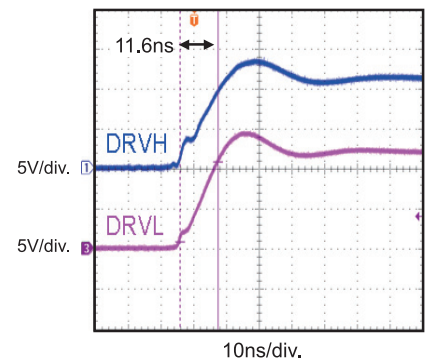
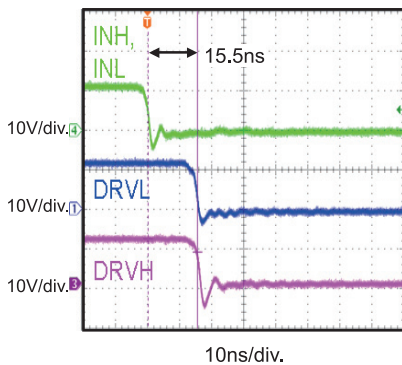
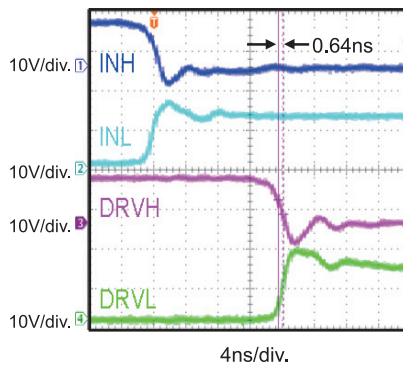
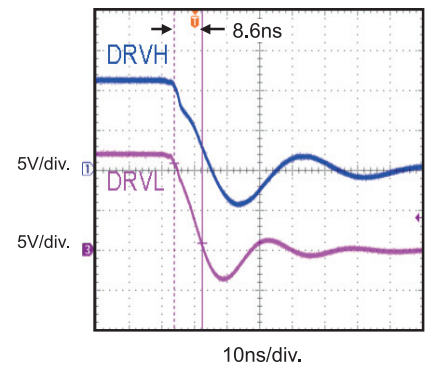
Peak Current vs. V_{DD} Voltage

Turn-On Propagation Delay

Gate Drive Matching T_{MOFF}

Drive Rise Time (1nF Load)

Turn-Off Propagation Delay

Gate Drive Matching T_{MON}

Drive Fall Time (1nF Load)

BLOCK DIAGRAM

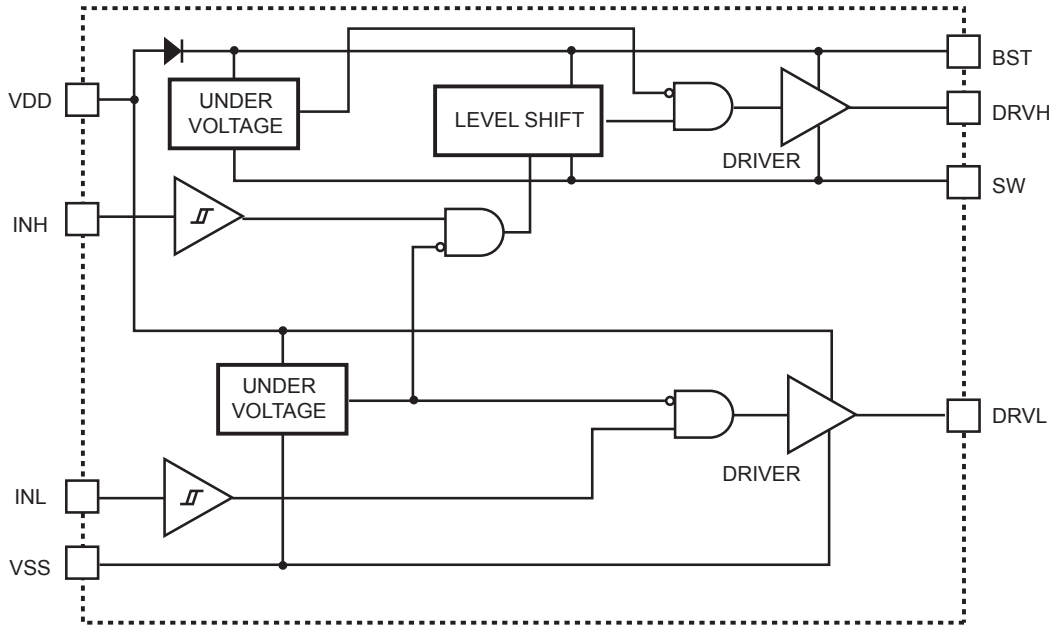

Figure 2: Function Block Diagram

APPLICATION

The INH and INL input signals can be controlled independently. If both INH and INL are controlling the HS-FET and LS-FET of the same bridge, then users must avoid shoot-through by setting

a sufficient dead time between INH and INL low, and vice versa (see Figure 3). Dead time is the time interval between INH low and INL low.

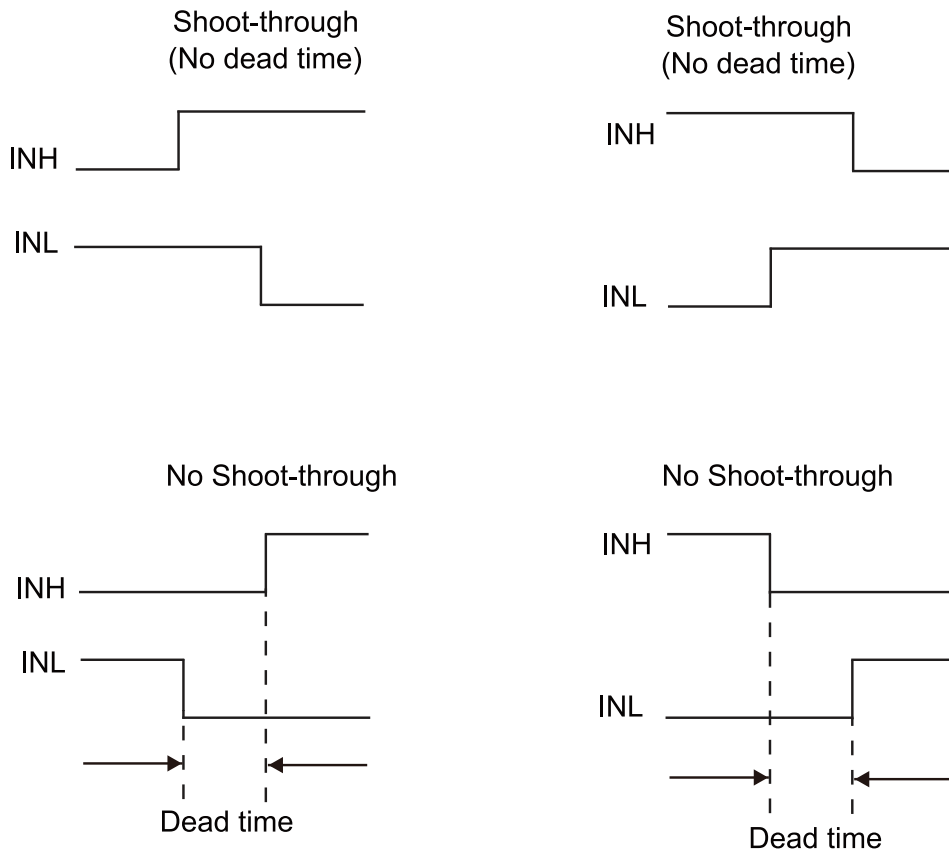

Figure 3: Short-Through Timing Diagram

REFERENCE DESIGN CIRCUITS

Half-Bridge Converter

In half-bridge converter topology, the MOSFETs are driven alternately with dead time. Therefore, INH and INL are driven with alternating signals

from the PWM controller (see Figure 4). Input voltage can be up to 100V in this application.

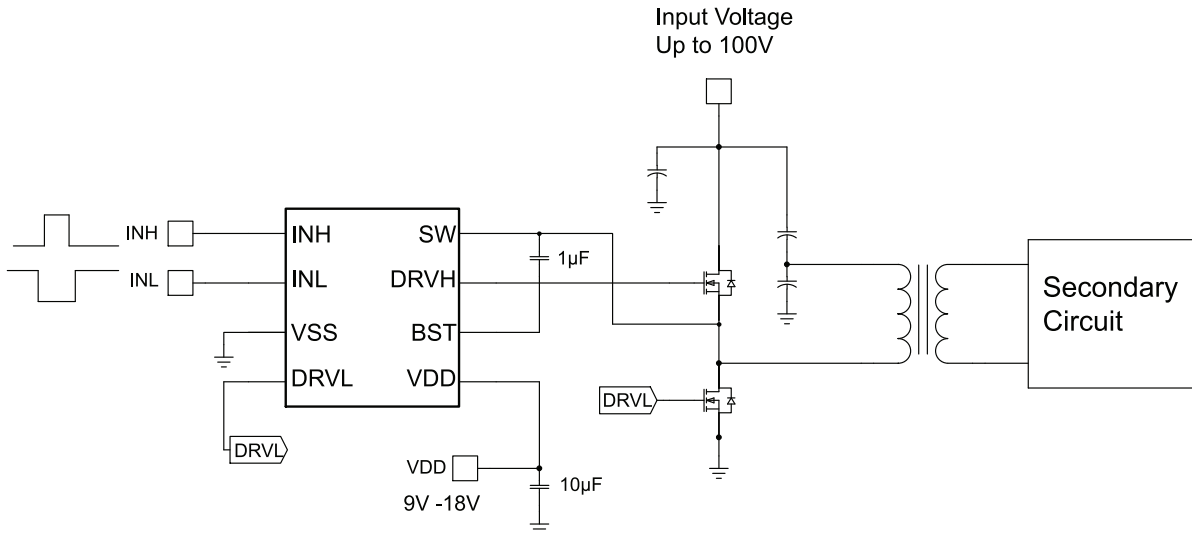

Figure 4: Half-Bridge Converter

Two-Switch Forward Converter

In two-switch forward converter topology, both MOSFETs are turned on and off together. The input signal (INH and INL) comes from the PWM controller, which senses the output voltage and output current if current-mode control is used (see

Figure 5). The Schottky diodes clamp the reverse swing of the power transformer, and must be rated at the input voltage. Input voltage can be up to 100V in this circuit.

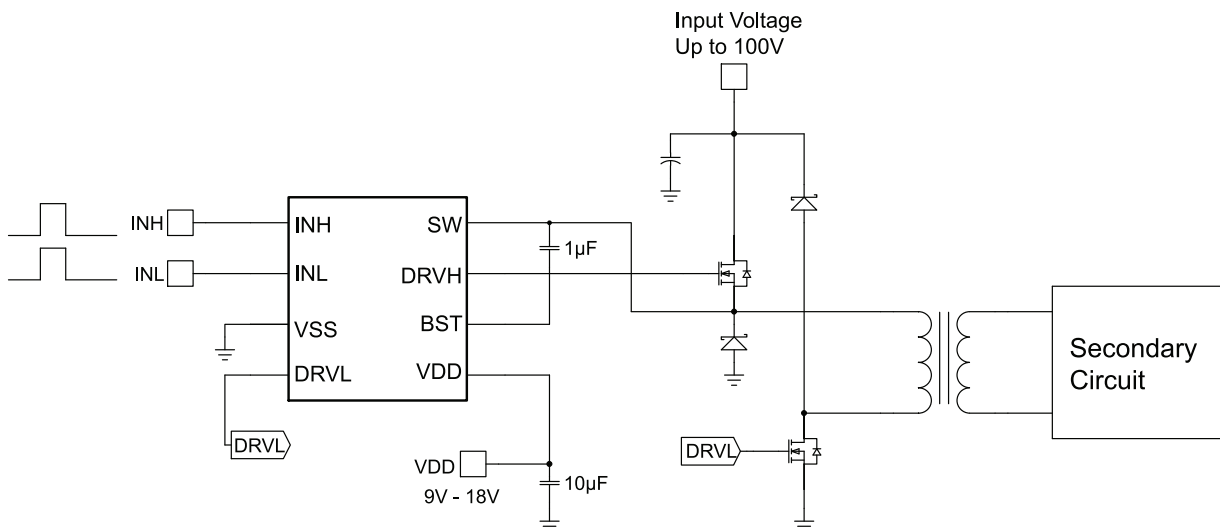

Figure 5: Two-Switch Forward Converter

Active-Clamp Forward Converter

In active-clamp forward converter topology, the MOSFETs are driven alternately. The high-side MOSFET, along with capacitor C_{reset} , is used to reset the power transformer in a lossless manner.

This topology lends itself well to run at duty cycles exceeding 50%. For these reasons, the input voltage may not be able to run at 100V for this application.

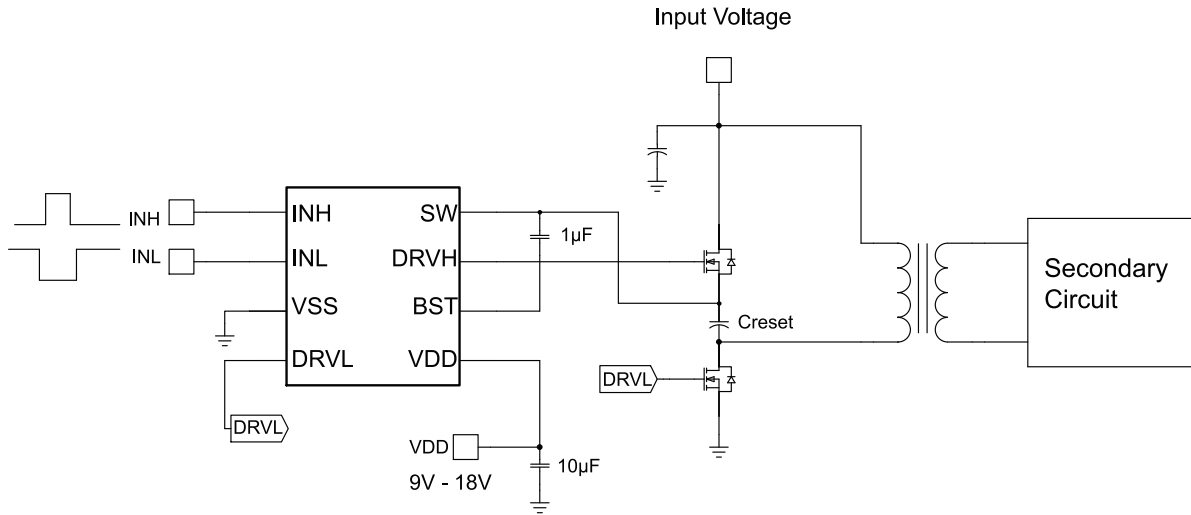
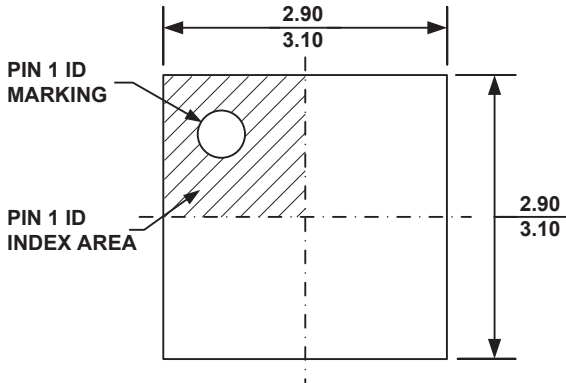

Figure 6: Active-Clamp Forward Converter

PACKAGE INFORMATION

QFN10 (3mm×3mm)



TOP VIEW

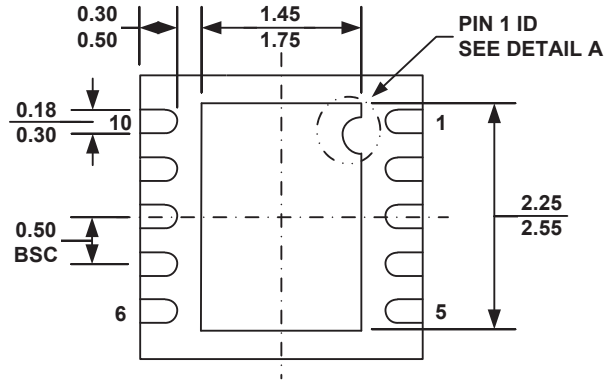

BOTTOM VIEW

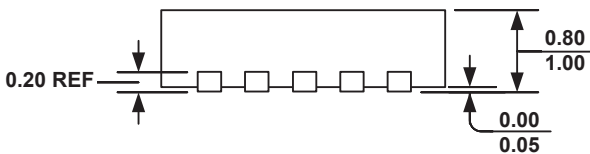

SIDE VIEW

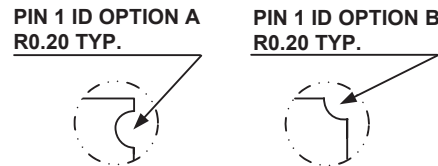

DETAIL A

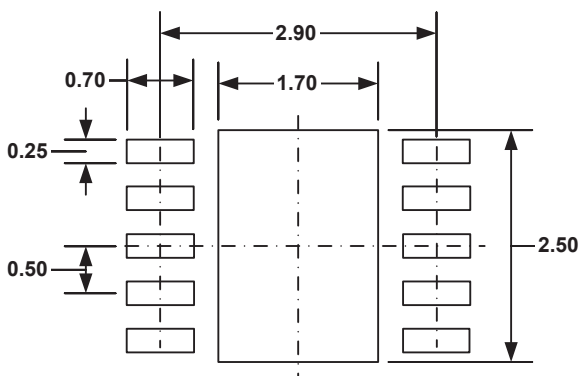

RECOMMENDED LAND PATTERN

NOTE:

- 1) ALL DIMENSIONS ARE IN MILLIMETERS.
- 2) EXPOSED PADDLE SIZE DOES NOT INCLUDE MOLD FLASH.
- 3) LEAD COPLANARITY SHALL BE 0.10 MILLIMETER MAX.
- 4) DRAWING CONFORMS TO JEDEC MO-229, VARIATION VEED-5.
- 5) DRAWING IS NOT TO SCALE.

NOTICE: The information in this document is subject to change without notice. Users should warrant and guarantee that third party Intellectual Property rights are not infringed upon when integrating MPS products into any application. MPS will not assume any legal responsibility for any said applications.