



EVQ6631H-L-00A

35V, 3A Peak Phase Current 3-Phase BLDC Motor Driver Evaluation Board

DESCRIPTION

The EVQ6631H-L-00A is an evaluation board designed for the MPQ6631H, a 3-phase brushless DC (BLDC) motor driver with integrated power MOSFETs. The MPQ6631H drives a 3-phase BLDC motor with 1 external Hall sensor or 3 external Hall sensors. The peak phase current is up to 3A across the 3.6V to 35V input voltage (V_{IN}) range.

The MPQ6631H controls the motor speed through the pulse-width modulation (PWM) signal, or it controls the DC signal on the PWM/DC pin. The device provides closed-/open-loop control and a built-in, configurable speed curve function. The device also features a sinusoidal drive for maximum torque, as well as low speed ripple and noise across the full speed range.

The MPQ6631H has a rotational speed detector feature. The rotational speed detector (the FG/RD pin) is an open-drain output. FG/RD outputs a high or low voltage relative to the Hall sensor comparator's output. In addition to rotational speed detection, the direction is controlled via the DIR pin's input.

Protections include input over-voltage protection (OVP), under-voltage lockout (UVLO), locked-rotor protection, over-current protection (OCP), and thermal shutdown.

The MPQ6631H is available in a TQFN-26 (3mmx4mm) package with wettable flanks. It is available in AEC-Q100 Grade 1.

PERFORMANCE SUMMARY

Specifications are at $T_A = 25^\circ\text{C}$, unless otherwise noted.

Parameters	Conditions	Value
Input voltage (V_{IN}) range		5V to 35V
Maximum output phase current (I_{OUT})	$V_{IN} = 5V$ to 35V	3A
Input pulse-width modulation (PWM) frequency		1kHz to 100kHz
Switching frequency (f_{sw})		25kHz

EVALUATION BOARD

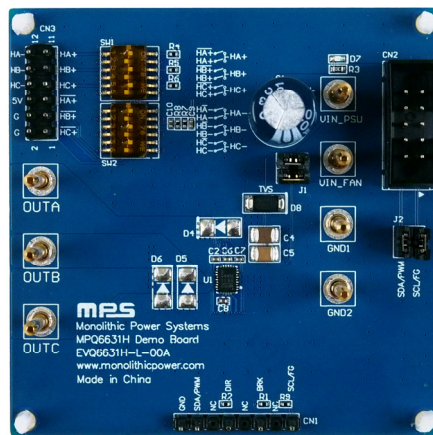

LxWxH (7cmx7cmx2.2cm)

Board Number	MPS IC Number
EVQ6631H-L-00A	MPQ6631HGLTE-0000

QUICK START GUIDE

Quick Start using the Communication Kit (MPS Fan Driver Communication Kit)

1. Preset the DC power supply, then turn the power supply off.
2. Connect the power supply outputs to VIN_PSU and GND (see Figure 1).
3. Connect the communication kit to the EVQ6631H-L-00A via CN2.
4. Connect the motor phase terminals to:
 - a. Motor phase A: OUTA
 - b. Motor phase B: OUTB
 - c. Motor phase C: OUTC
5. Connect the motor's Hall sensor outputs to the corresponding connector.
6. Connect the communication kit to the computer.
7. Turn the power supply on.
8. Run the Windows application "MPQ6631H.exe".

Figure 1 shows the equipment set-up with the communication kit.

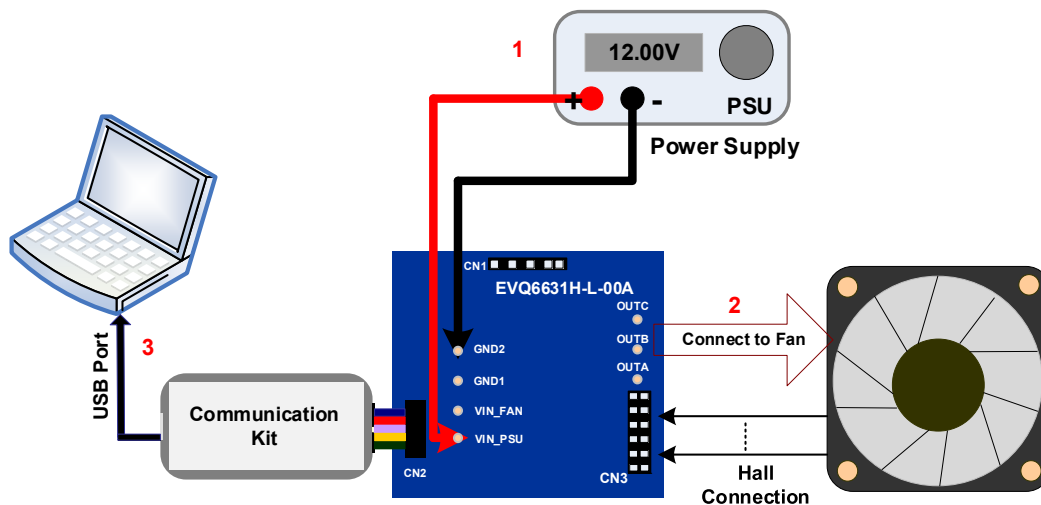

Figure 1: EVB Connection with the Communication Kit

Quick Start without the Communication Kit

1. Connect the power supply output terminals to VIN_FAN and GND.
2. Connect the motor phase terminals to:
 - a. Motor phase A: OUTA
 - b. Motor phase B: OUTB
 - c. Motor phase C: OUTC
3. Connect the motor's Hall sensor outputs to the corresponding connector. See The Hall Connection section on page 3 for more details.
4. Turn the power supply on. The motor should begin working.

- Set the function generator to pulse mode, such that the high level is 3.3V and the low level is 0V. Adjust the pulse duty cycle to adjust the motor’s speed.

Figure 2 shows the equipment set-up without the communication kit.

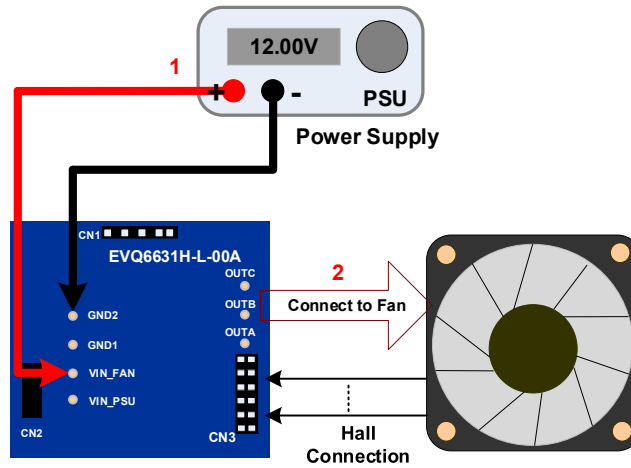

Figure 2: EVB Connection without the Communication Kit

The Hall Connection

The EVQ6631H-L-00A supports either a Hall IC (logic polarity input) or a Hall element (differential input) as the Hall input signal. Figure 3 shows the Hall IC that outputs the logic polarity signal.

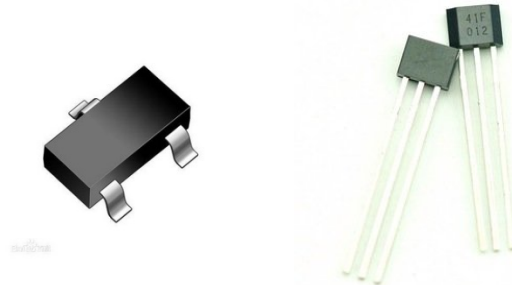

Figure 3: Hall IC (Output Logic Polarity Signal)

Figure 4 shows the Hall element that outputs the differential signal.

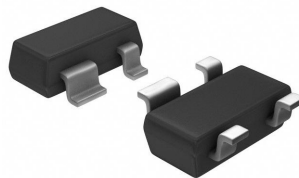

Figure 4: Hall Element (Output Differential Signal)

Hall IC Connection

1. Connect CN3 5V to the Hall IC's supply terminal.
2. Connect CN3 GND to the Hall IC's ground.
3. Connect the CN3 terminals (HA+, HB+, and HC+) to their corresponding terminals in the Hall IC's output. Do not make connections for HA-, HB-, and HC-.

Then use SW1 and SW2 to switch to the correct terminal (see Figure 5).

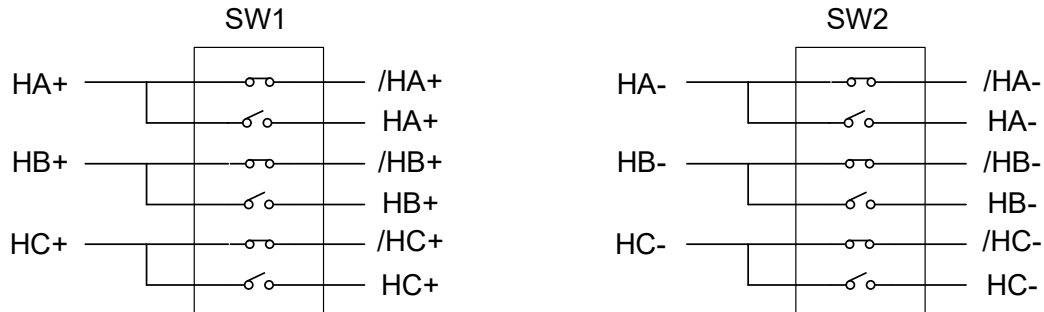

Figure 5: SW1 and SW2 with the Hall IC Connection

Hall Element Connection

1. Connect CN3 5V to the Hall element's supply terminal.
2. Connect CN3 GND to the Hall element's ground.
3. Connect the CN3 terminals to:
 - a. The Hall element's positive (+) output: HA+, HB+, and HC+
 - b. The Hall element's negative (-) output: HA-, HB-, and HC-

Then use SW1 and SW2 to switch to the correct terminal (see Figure 6).

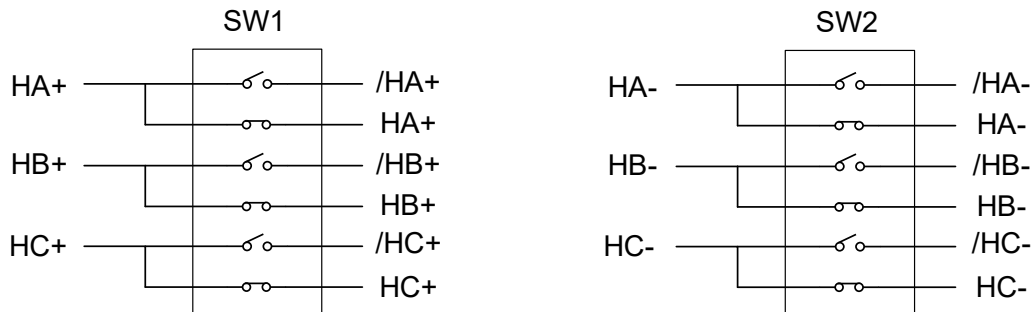

Figure 6: SW1 and SW2 with the Hall Element Connection

GUI Operation Guide

1. Double click “MPQ6631H.exe” to start the GUI. The first page of GUI should show the features and typical application circuit (see Figure 7).

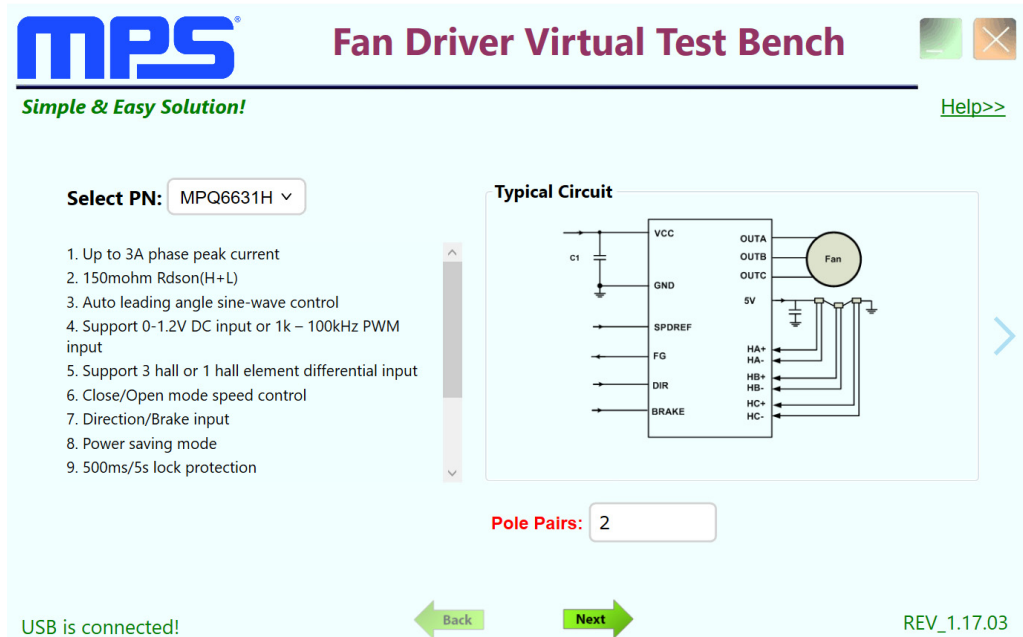

Figure 7: Fan Driver Virtual Test Bench

2. Insert the motor’s pole pairs, then click “Next”.

General Settings

There are a few general settings in the GUI, listed below.

1. Test Mode: Use test mode to begin a new design. When test mode is automatically selected, all internal register can be accessed.
2. Bench Verification: Automatically tests the RPM curve.
3. Reset Fan: Resets the hardware and the motor if a fault occurs.
4. Programming: Use the programming feature to load code files and make configurations via the one-time programmable (OTP) memory.

Figure 8 on page 6 shows the general settings page.

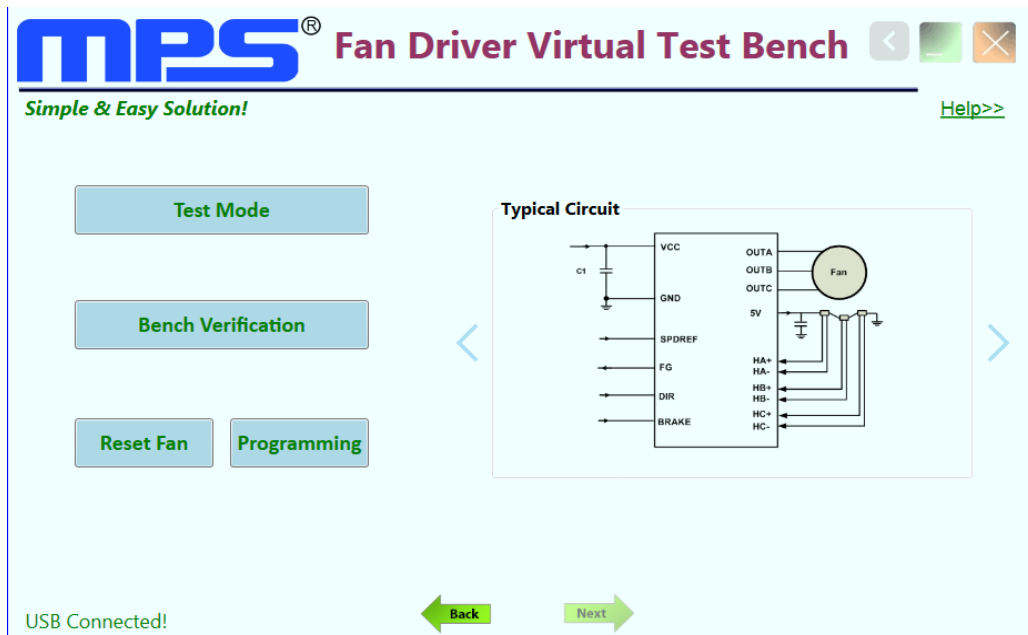

Figure 8: General Settings Page

Click “Test Mode” to enter the test mode interface. The GUI software should read back the MPQ6631H’s register data and display the information.

EVALUATION BOARD SCHEMATIC

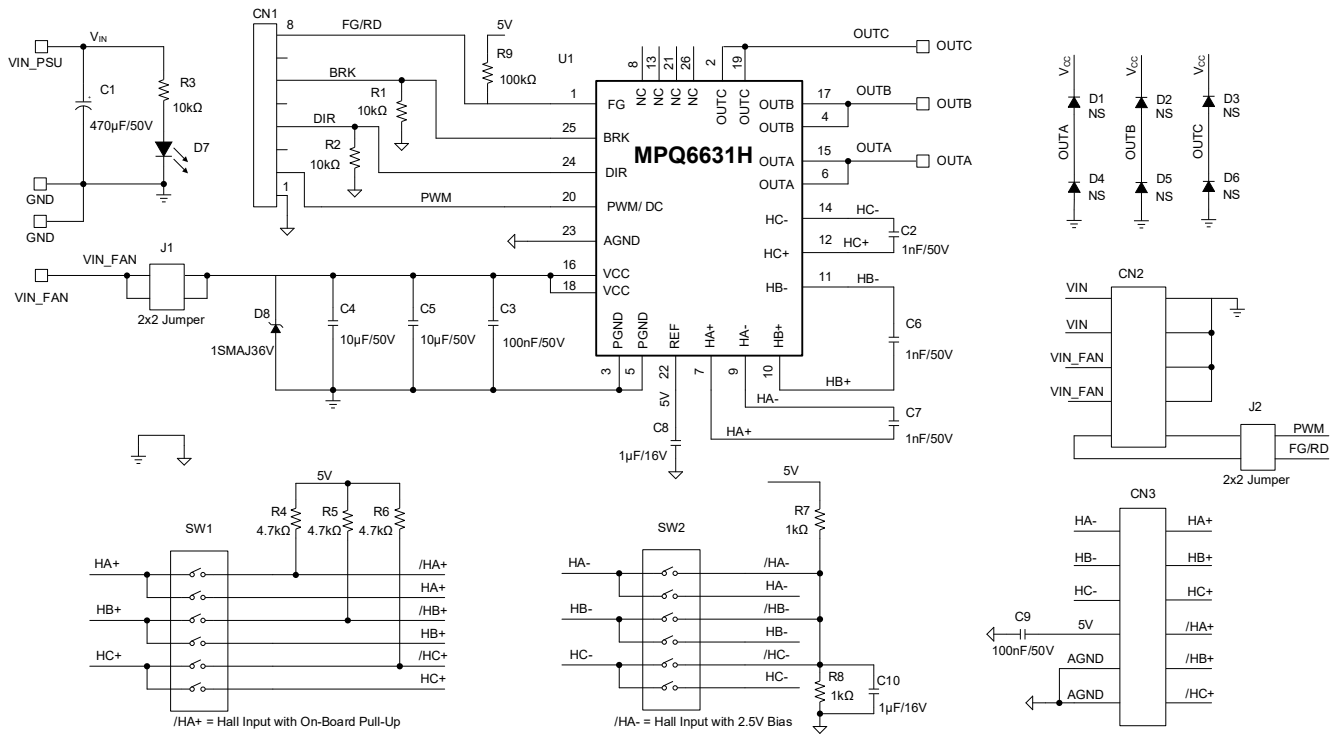

Figure 9: Evaluation Board Schematic

EVQ6631H-L-00A BILL OF MATERIALS

Qty	Ref	Value	Description	Package	Manufacturer	Manufacturer PN
1	C1	470µF, 50V	Electrolytic capacitor, 50V, 470µF	DIP	Wurth	860020675022
3	C2, C6, C7	1nF, 50V	Ceramic capacitor, 50V, X7R	0402	Murata	GCM155R71H102KA37D
2	C3, C9	100nF, 50V	Ceramic capacitor, 50V, X7R	0402	Murata	GRM155R71H104KE14D
2	C4, C5	10µF, 50V	Ceramic capacitor, 50V, X7R	1210	Murata	GRM32ER71H106KA12L
2	C8, C10	1µF, 16V	Ceramic capacitor, 16V, X6S	0402	Murata	GRM155C81C105KE11D
2	R1, R2	10kΩ	Film resistor, 1%	0402	Yageo	RC0402FR-0710KL
1	R3	10kΩ	Film resistor, 1%	0603	Yageo	RC0603FR-0710KL
3	R4, R5, R6	4.7kΩ	Film resistor, 1%	0402	Yageo	RC0402FR-074K7L
2	R7, R8	1kΩ	Film resistor, 1%	0402	Yageo	RC0402FR-071KL
1	R9	100kΩ	Film resistor, 1%	0402	Yageo	RC0402FR-07100KL
6	D1, D2, D3, D4, D5, D6	NC				
1	D7	Red	Red LED	0603	Bright LED	BL-HUE36A-AV-TRB
1	D8	36V, 6.9A	TVS diode	SMA	Semtech	1SMA36A
7	GND1, GND2, VIN_FAN, VIN_PSU, OUTA, OUTB, OUTC	2mm	2mm connector	DIP	Any	
1	CN1	8-pin	Connector, header, 1x8-pin, 2.54mm	DIP	Any	
1	CN2	5-pin	Header, 5-pin, dual-row, with frame	DIP	Any	
1	CN3	6-pin	Connector, 2x6-pin, 2.54mm	DIP	Any	
2	J1, J2	2-pin	Connector, jumper, 2x2-pin, 2.54mm	DIP	Any	
2	SW1, SW2	1.27mm	6 positions, 1.27mm pitch switch	SMD	Wurth	416131160806
1	U1	MPQ6631H	3-phase motor driver with Hall input	TQFN-26 (3mmx4mm) WF	MPS	MPQ6631HGLTE-0000

EVB TEST RESULTS

Performance curves and waveforms are tested on the evaluation board, $V_{IN} = 12V$, PWM frequency = 20kHz, with 1 external Hall sensor or 3 external Hall sensors, unless otherwise noted.

Steady State

PWM duty cycle = 100%, DIR = low, counterclockwise

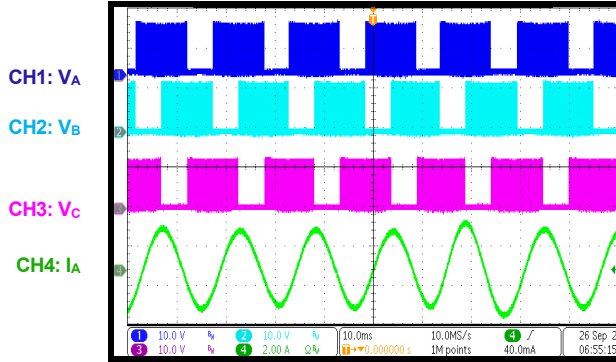

Steady State

PWM duty cycle = 50%, DIR = low, counterclockwise

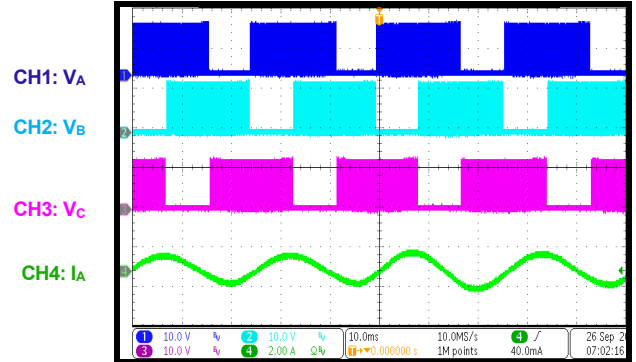

Steady State

PWM duty cycle = 100%, DIR = high, clockwise

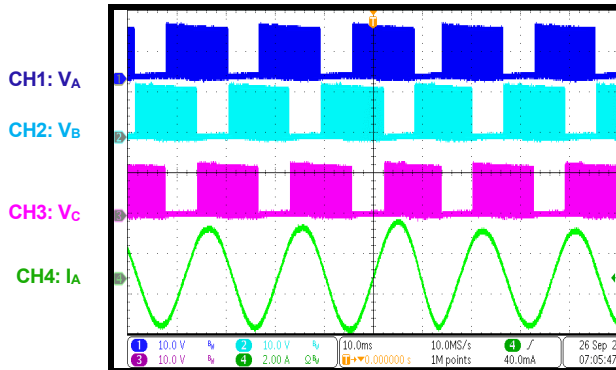

Steady State

PWM duty cycle = 50%, DIR = high, clockwise

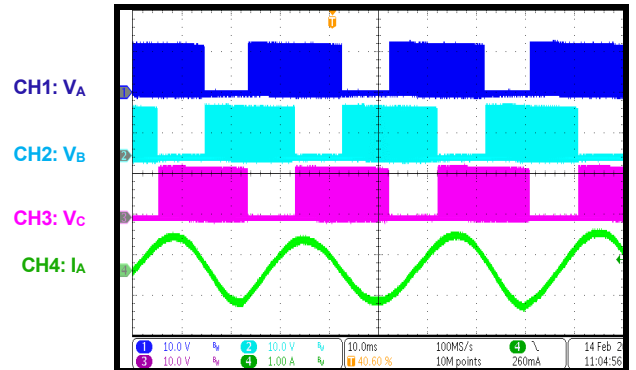

PWM On

PWM duty cycle = 0% to 100%, 3 Hall sensors, DIR = low, counterclockwise

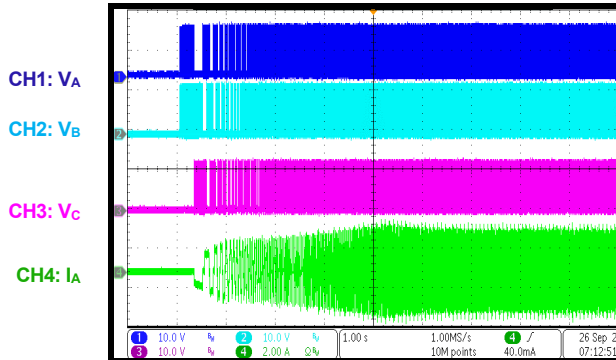

PWM On

PWM duty = 0% to 100%, 3 Hall sensors, DIR = high, clockwise

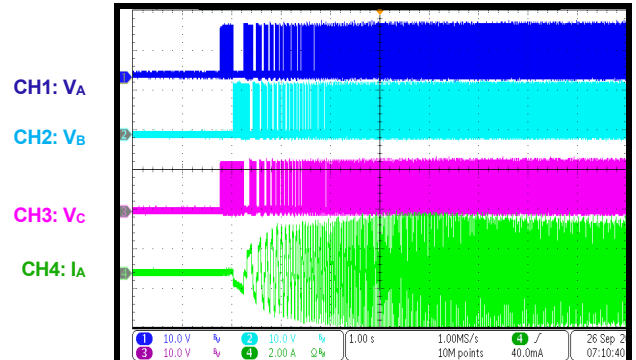

EVB TEST RESULTS *(continued)*

Performance curves and waveforms are tested on the evaluation board, $V_{IN} = 12V$, PWM frequency = 20kHz, with 1 external Hall sensor or 3 external Hall sensors, unless otherwise noted.

PWM On

PWM duty cycle = 0% to 100%, 1 Hall sensor, DIR = low, counterclockwise

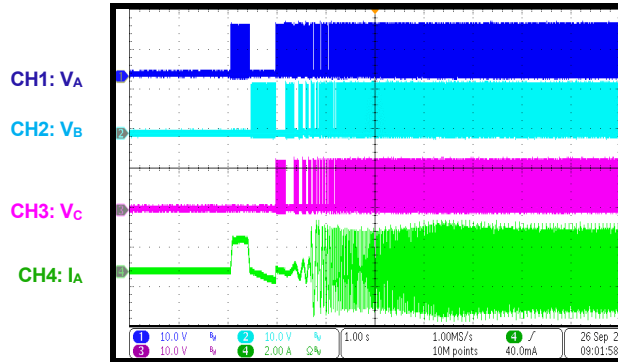

PWM On

PWM duty = 0% to 100%, 1 Hall sensor, DIR = low, counterclockwise

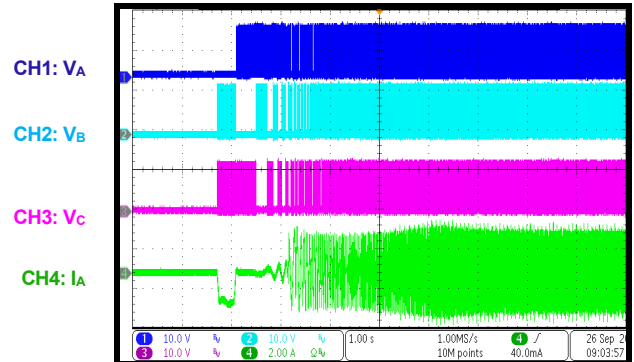

PWM On

PWM duty cycle = 0% to 100%, 1 Hall sensor, DIR = high, clockwise

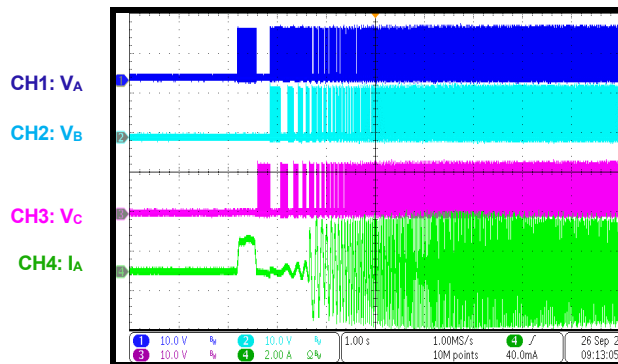

PWM On

PWM duty cycle = 0% to 100%, 1 Hall sensor, DIR = high, clockwise

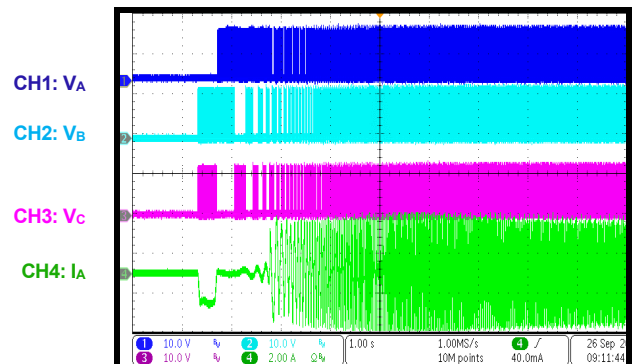

PWM Off

PWM duty cycle = 100% to 0%, DIR = low, counterclockwise

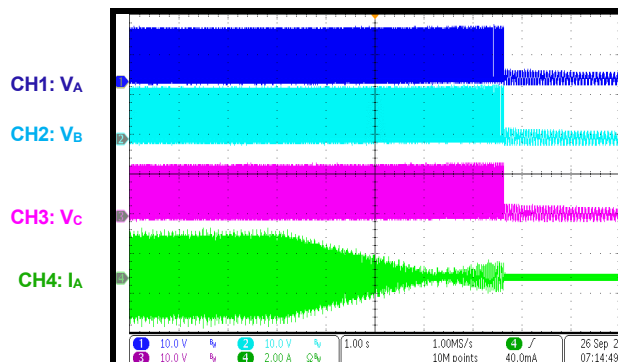

PWM Off

PWM duty cycle = 100% to 0%, DIR = high, clockwise

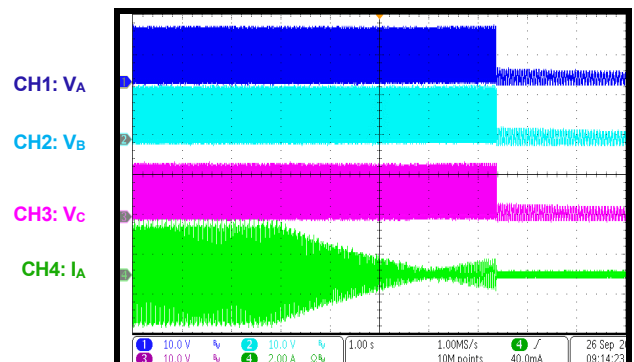

EVB TEST RESULTS (continued)

Performance curves and waveforms are tested on the evaluation board, $V_{IN} = 12V$, PWM frequency = 20kHz, with 1 external Hall sensor or 3 external Hall sensors, unless otherwise noted.

Start-Up through VCC

$V_{CC} = 0V$ to $12V$, PWM duty cycle = 100%, 1 Hall sensor, DIR = low, counterclockwise

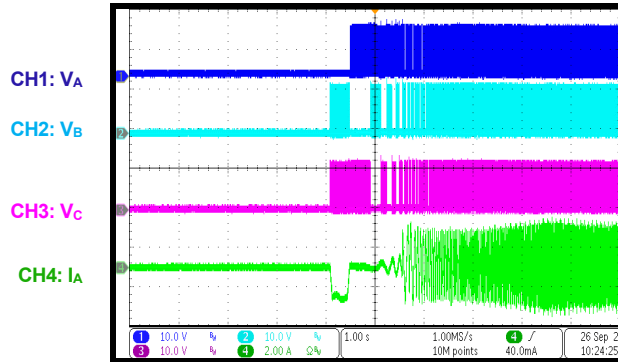

Start-Up through VCC

$V_{CC} = 0V$ to $12V$, PWM duty cycle = 100%, 3 Hall sensors, DIR = low, counterclockwise

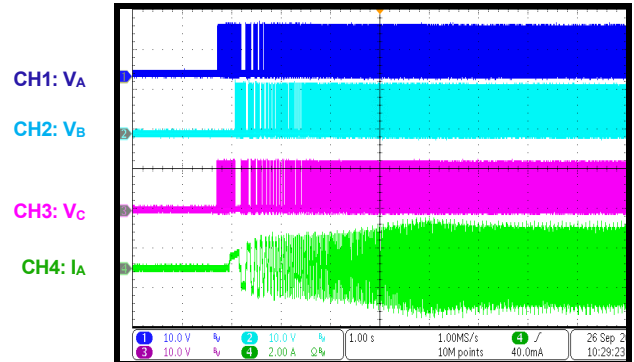

Shutdown through VCC

$V_{CC} = 12V$ to $0V$, PWM duty cycle = 100%, DIR = low, counterclockwise

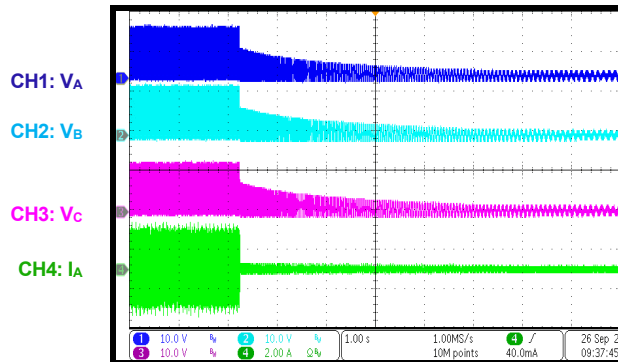

Lock and Retry

PWM duty cycle = 25%, 3 Hall sensors, lock rotor then release

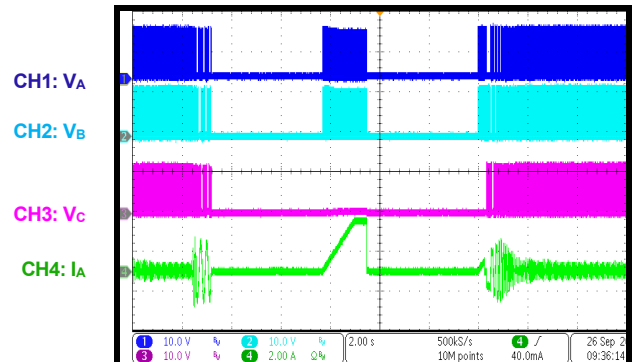

Lock and Retry

PWM duty cycle = 25%, 1 Hall sensor, lock rotor then release

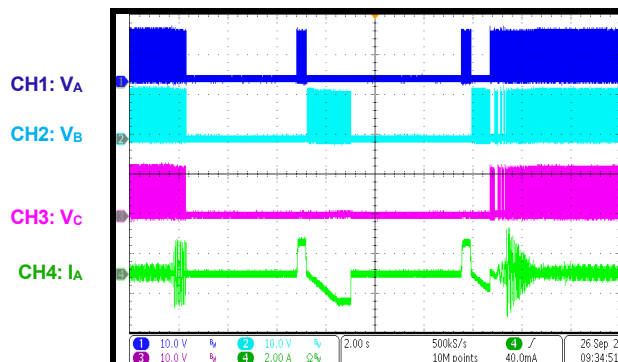

PCB LAYOUT

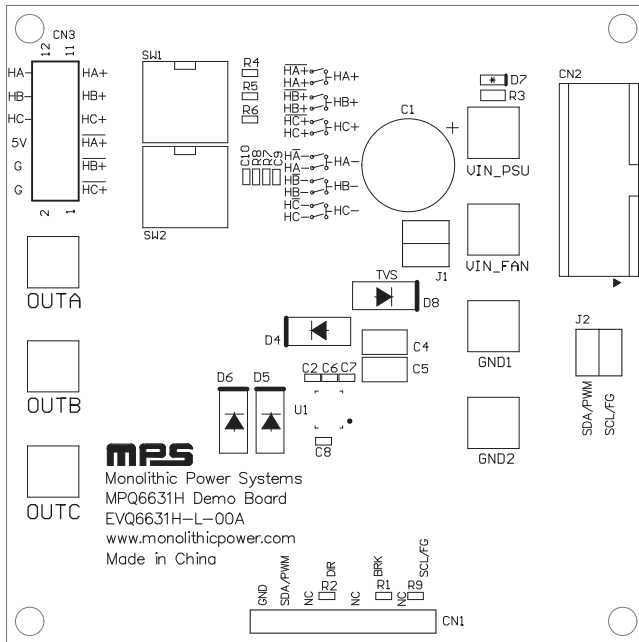

Figure 10: Top Silk

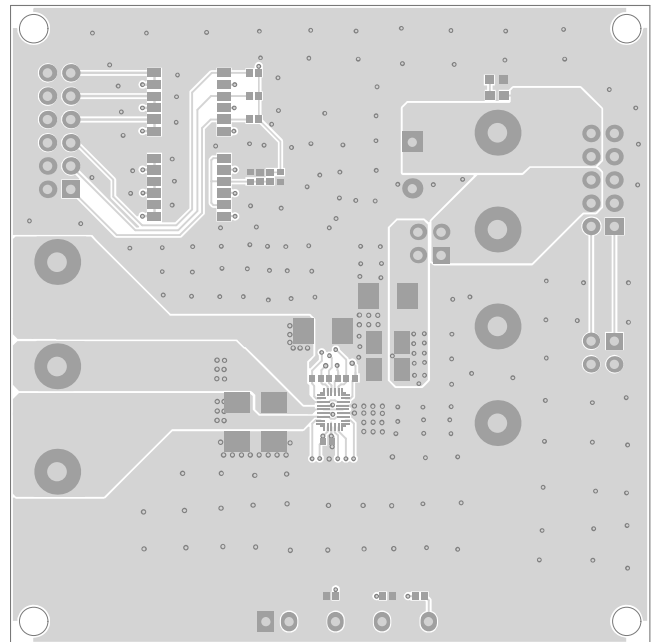

Figure 11: Top Layer

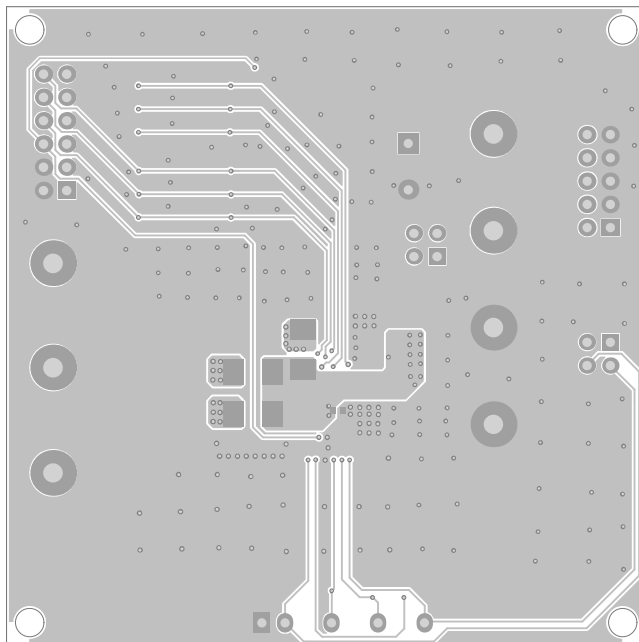

Figure 12: Bottom Layer

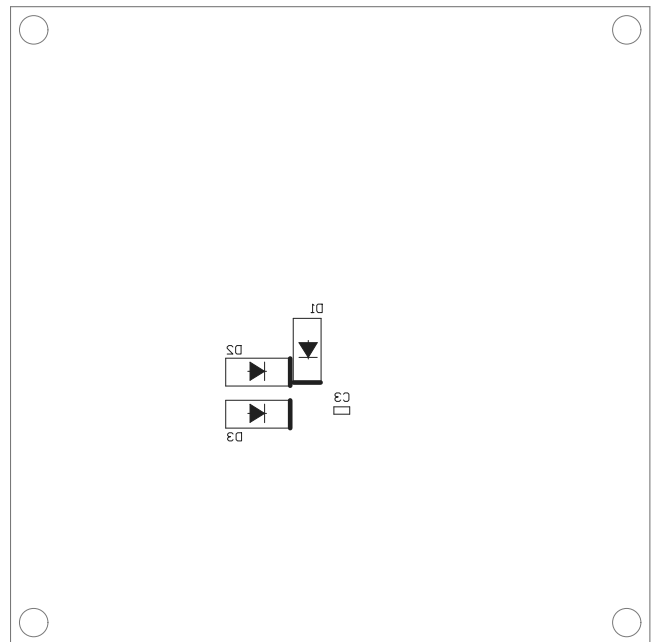

Figure 13: Bottom Silk



REVISION HISTORY

Revision #	Revision Date	Description	Pages Updated
1.0	2/26/2024	Initial Release	-

Notice: The information in this document is subject to change without notice. Please contact MPS for current specifications. Users should warrant and guarantee that third-party Intellectual Property rights are not infringed upon when integrating MPS products into any application. MPS will not assume any legal responsibility for any said applications.