



The Future of Analog IC Technology®

EV6519-Q-00A

5A, 28V

H-Bridge Current Regulator
Evaluation Board

DESCRIPTION

The EV6519-Q-00A is an evaluation board for the MP6519, a monolithic, step-down, current-source driver. It operates from a supply voltage of up to 28V and can deliver current up to 5A.

The four integrated MOSFET H-bridge control provide a fast dynamic load response and an ultra-high efficiency solution. For ease of use, the output polarity can be controlled by pulling MODE high or low.

Full Protection features include load open, load-short protection, OCP, OTP, OVP.

ELECTRICAL SPECIFICATIONS

Parameter	Symbol	Value	Units
Input Voltage	V_{IN}	2.5 – 28	V
Maximum Output Current	I_{OUT-L}	5	A

FEATURES

- Wide 2.5V to 28V Input Voltage Range
- Up to 5A Output Peak Current
- $\pm 2\%$ Accuracy at Full-Scale Reference
- $65m\Omega$ $R_{DS(ON)}$ for Each MOSFET of H-Bridge
- 30kHz to 300kHz Programmable Switching Frequency
- 20k-100kHz PWM Input for Current Regulation
- Programmable Full-Scale Current
- Selectable Current Polarity Mode
- Open-Load Protection, OCP, OTP, OVP

APPLICATIONS

- Current Regulators
- DC Motors
- Solenoid/Actuators

All MPS parts are lead-free, halogen free, and adhere to the RoHS directive. For MPS green status, please visit MPS website under Quality Assurance. "MPS" and "The Future of Analog IC Technology" are Registered Trademarks of Monolithic Power Systems, Inc.

EV6519-Q-00A EVALUATION BOARD



(L x W x H) 3.25" x 3.25" x 0.4"
(8.13cm x 8.13cm x 1cm)

Board Number	MPS IC Number
EV6519-Q-00A	MP6519

EVALUATION BOARD SCHEMATIC

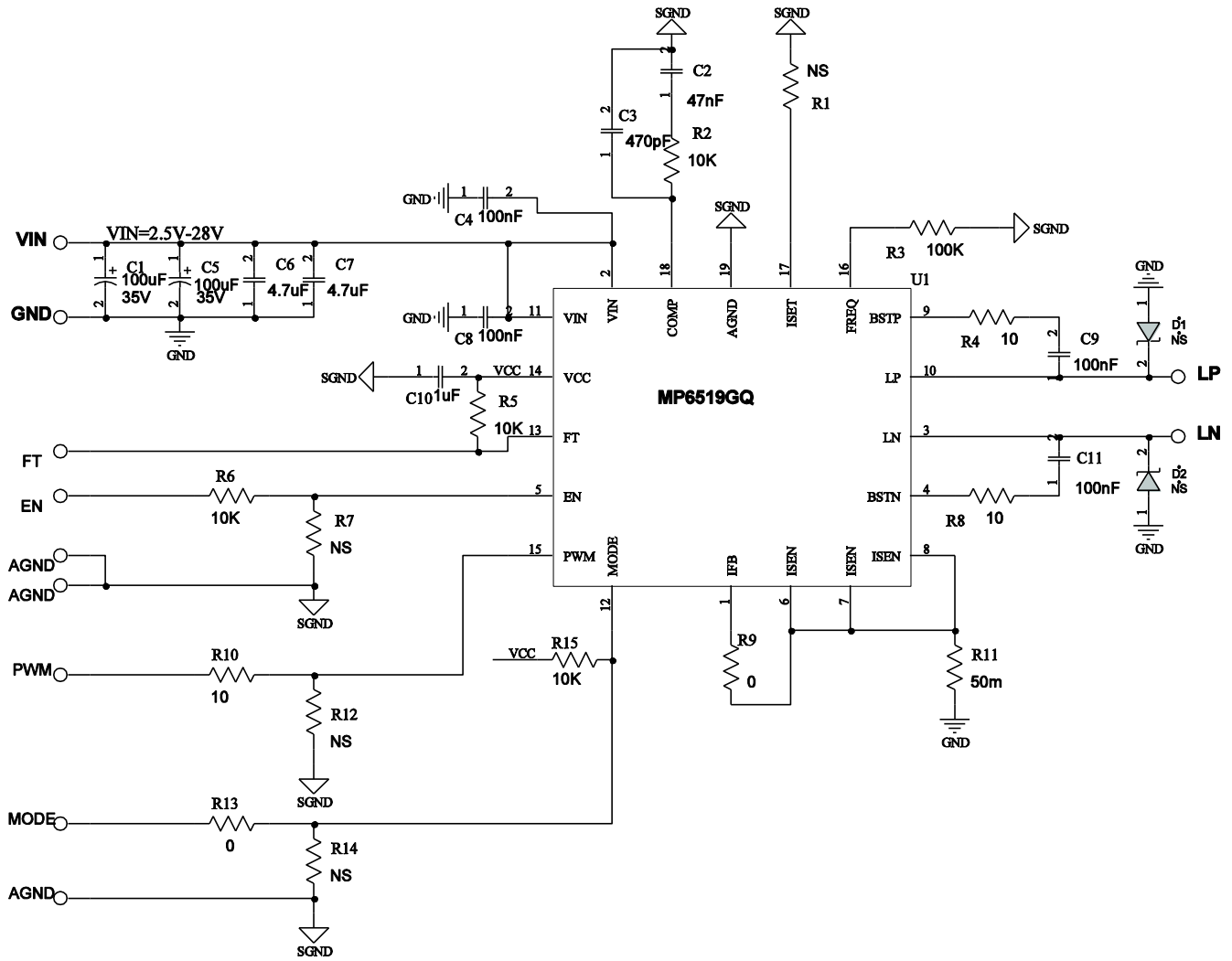

EV6519-Q-00A BILL OF MATERIALS

Qty	Ref	Value	Description	Package	Manufacturer	Part Number
2	C1, C5	100 μ F	Electrolytic Capacitor; 35V;Electrolytic	DIP	Jianghai	CD287-35V100
1	C2	47nF	Ceramic Capacitor; 50V;X7R;0402	0402	TDK	C1608X7R1H473K
1	C3	470pF	Ceramic Capacitor; 50V;X7R;0402	0402	muRata	GRM188R71H471KA01D
4	C4, C8, C9,C11	100nF	Ceramic Capacitor; 50V;X7R;0402	0402	TDK	C1005X7R1H104K
2	C6, C7	4.7 μ F	Ceramic Capacitor; 50V;X7R;1210;	1210	muRata	GRM32ER71H475KA88L
1	C10	1 μ F	Ceramic Capacitor; 25V;X7R;0402	0402	muRata	GRM155R61E105KA12
2	D1, D2	NS				
4	R1, R7, R12,R14	NS				
4	R2, R5, R6, R15	10k	Film Resistor;1%	0402	Yageo	RC0402FR-0710KL
1	R3	100k	Film Resistor;1%	0402	Yageo	RC0402FR-07100KL
3	R4, R8, R10	10	Film Resistor;1%	0402	Yageo	RC0402FR-0710RL
2	R9, R13	0	Film Resistor;1%	0402	Yageo	RC0402FR-070RL
1	R11	50m	Film Resistor;1%	3720	CYNTEC	RL3720WT-R050-FN
4	VIN, GND, LP, LN		Connector; 2MM			
7	AGND, PWM, FT, MODE, EN		Test point			
1	U1	MP6519GQ	Step down current driver	QFN-19 (3mmx3mm)	MPS	MP6519GQ-R2

PRINTED CIRCUIT BOARD LAYOUT

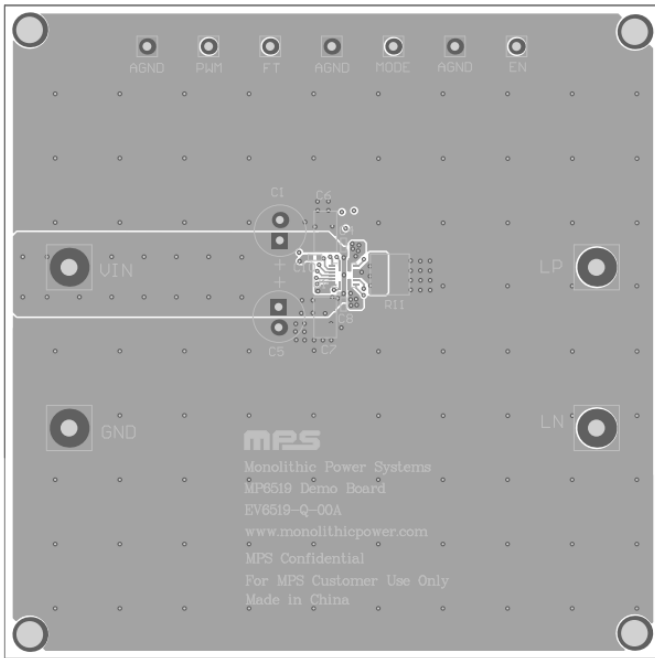

Figure 1—Top Layer

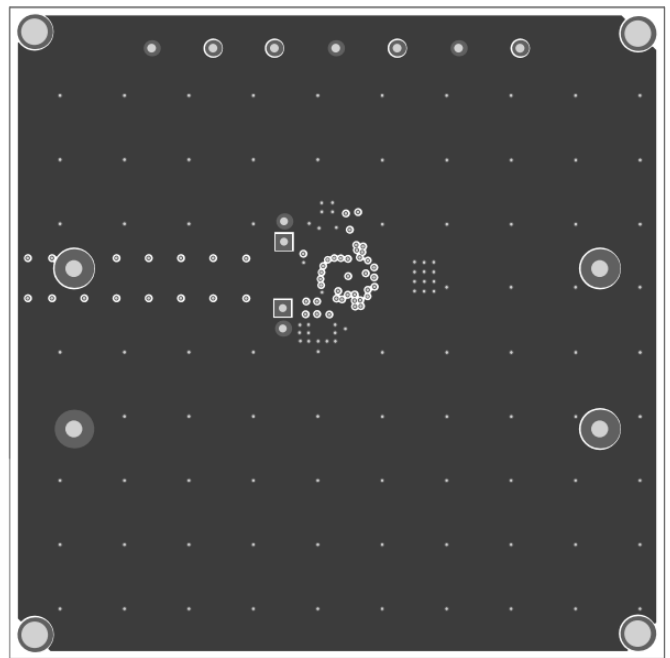

Figure 2—Mid Layer 1

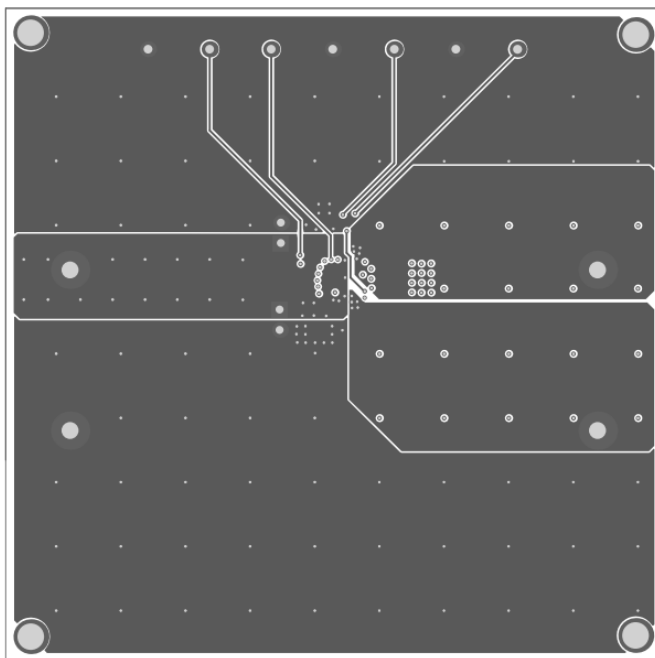

Figure 3—Mid Layer 2

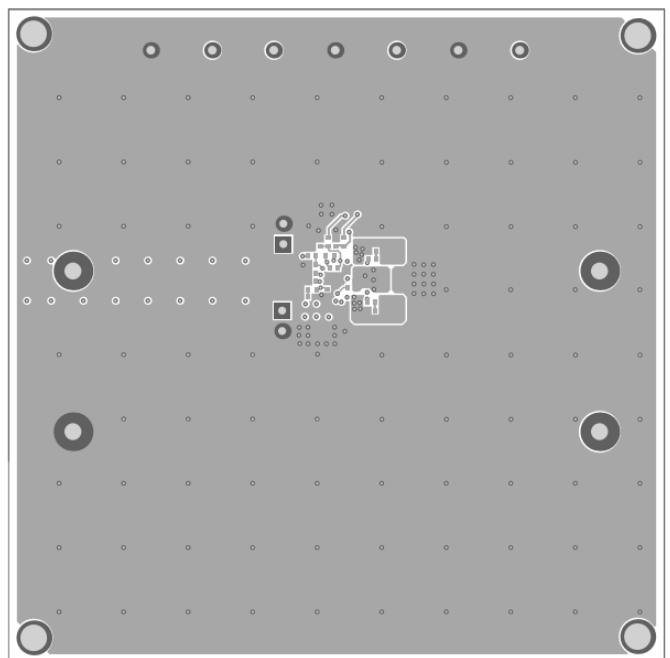

Figure 4—Bottom Layer

QUICK START GUIDE

1. Power Requirements

- a. Power supply range: 2.5V to 28V, 5A Max.

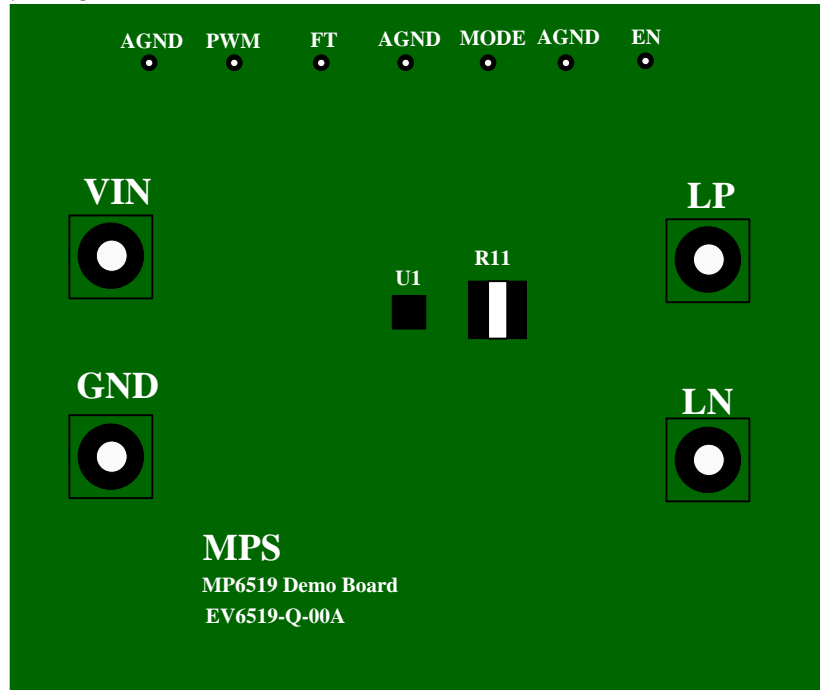

Figure 5 — EV6519-Q-00A Bird's-eye View

2. Setup Condition

- a. Adjust the power supply VIN with recommended operating range (2.5V to 28V).
- b. Connect proper load to LN and LP terminals.
- c. Apply external PWM signal with frequency range, 20kHz to 100kHz.
- d. Apply EN voltage (5V or 3.3V tolerance).
- e. Current direction is controlled by MODE pin, L=reverse, H=forward. MODE=H as default.
- f. The full-scale current reference value is set by R11. If the full-scale current reference is set, the actual output current sent to the error amplifier can be further controlled by applying a PWM input signal to PWM. Refer to the DS for details.

3. Monitors

- a. FT on the evaluation board indicates Over Temperature Protection and Over Current Protection. This is an open drain output with onboard 10k ohm pull-up resistor.

NOTICE: The information in this document is subject to change without notice. Users should warrant and guarantee that third party Intellectual Property rights are not infringed upon when integrating MPS products into any application. MPS will not assume any legal responsibility for any said applications.