



The Future of Analog IC Technology®

EV6515-L-00A 2A, 35V, H-Bridge Motor Driver Evaluation Board

DESCRIPTION

The EV6515-L-00A is an evaluation board for the MP6515, an H-Bridge motor driver.

It operates from a supply voltage of up to 35V and can deliver motor current up to 2A. The input control signals for the MP6515 are applied through the connector on the board.

ELECTRICAL SPECIFICATIONS

Parameter	Symbol	Value	Units
Input Voltage	V _{IN}	5.4 - 35	V
Maximum Output Current	I _{OUT-L}	2	A

FEATURES

- Wide 5.4V to 35V Input Voltage Range
- Up to 2A Output Current
- Internal Current Sense Output
- 3.3 and 5V Compatible Logic Supply
- OCP, OVP, OTP
- Fault Indication Output

APPLICATIONS

- Solenoid Drivers
- DC Brush Motor Drive

All MPS parts are lead-free, halogen free, and adhere to the RoHS directive. For MPS green status, please visit MPS website under Quality Assurance.

"MPS" and "The Future of Analog IC Technology" are Registered Trademarks of Monolithic Power Systems, Inc.

EV6515-L-00A EVALUATION BOARD

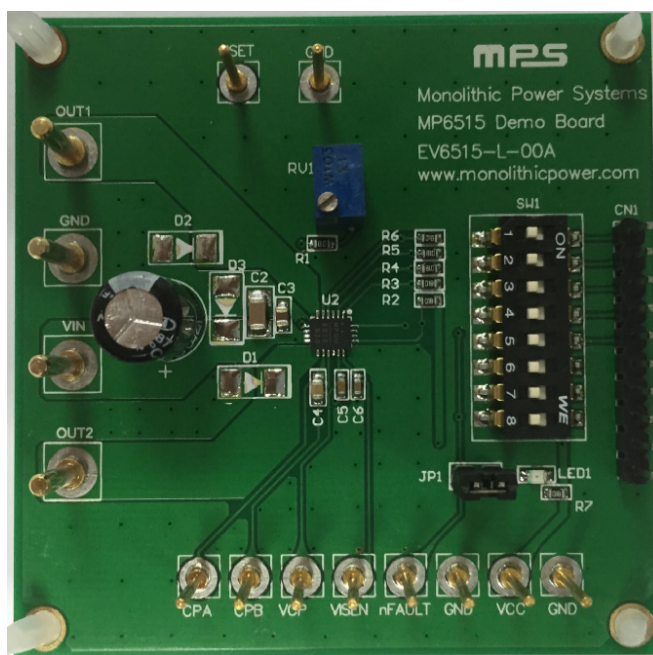

(L x W x H) 2.54" x 2.54" x 0.4"
(6.35cm x 6.35cm x 1cm)

Board Number	MPS IC Number
EV6515-L-00A	MP6515

EVALUATION BOARD SCHEMATIC

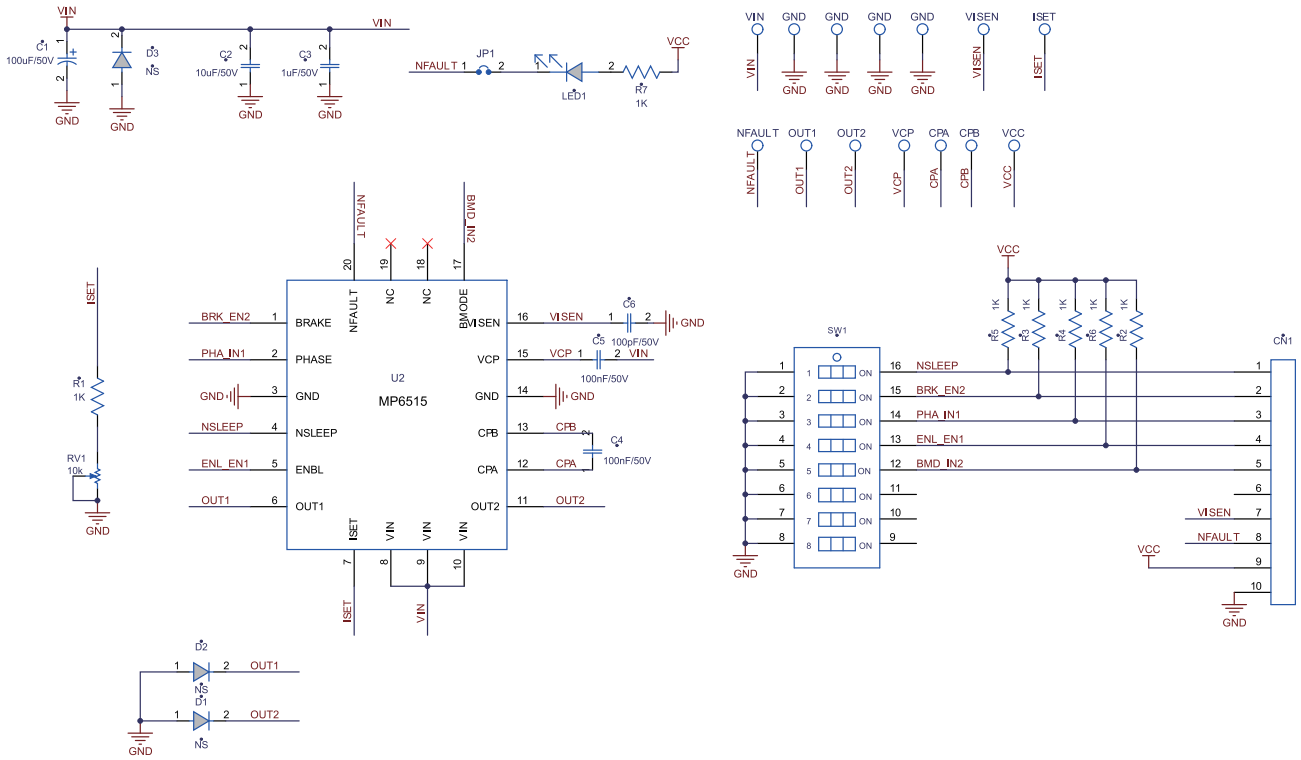

EV6515-L-00A BILL OF MATERIALS

Qty	RefDes	Value	Description	Package	Manufacturer	Manufacturer P/N
1	C1	100µF	Electrolytic Cap. 50V	DIP	JiangHai	CD287-50V100
1	C2	10µF	Ceramic Cap. 50V, X5R	1206	Murata	GRM31CR61H106KA12L
1	C3	1µF	Ceramic Cap. 50V, X7R	0805	Murata	GRM21BR71H105KA12L
1	C4	100nF	Ceramic Cap. 50V, X7R	0805	TDK	C2012X7R1H104K
1	C5	100nF	Ceramic Cap. 50V, X7R	0603	Murata	GCJ188R71H104KA12D
1	C6	100pF	Ceramic Cap. 50V, C0G	0603	Murata	GRM1885C1H101JA01D
7	R1, R2, R3, R4, R5, R6, R7	1k	Film Resistor. 1%	0603	Yageo	RC0603FR-071KL
1	RV1	10k	Adjustable Resistor	DIP		3296W-1-103F
1	LED1		LED. 红光	0805	Bright LED	BL-HUF35A-TRB
1	JP1		2PIN. 2.54MM			61304011121
1	JP1		2.54MM Short Jumper			60900213421
1	SW1		8-Bits Button	SMD	Würth	418121270808
1	CN1		10PIN. 2.54MM			61304011121
1	U2		H-Bridge Motor Driver	QFN20 (3mmx4mm)	MPS	MP6515GL
4	OUT1, OUT2, VIN, GND		2.0 公针			
10	CPA, CPB, VCP, VISEN, nFAULT, VCC, ISET, GND, GND, GND		1.0 公针			
3	D1, D2, D3	NS				

PRINTED CIRCUIT BOARD LAYOUT

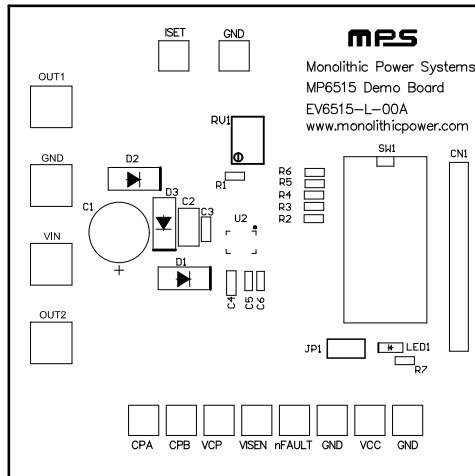

Figure 1: Top Silk Layer

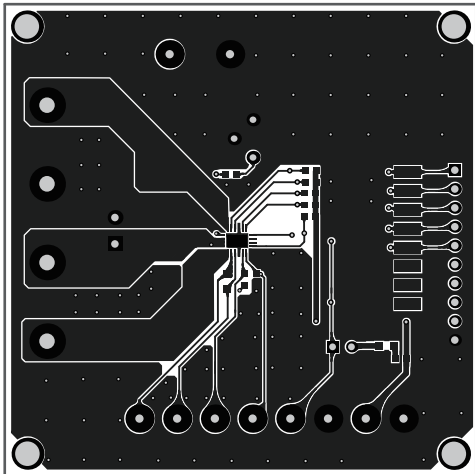

Figure 2: Top Layer

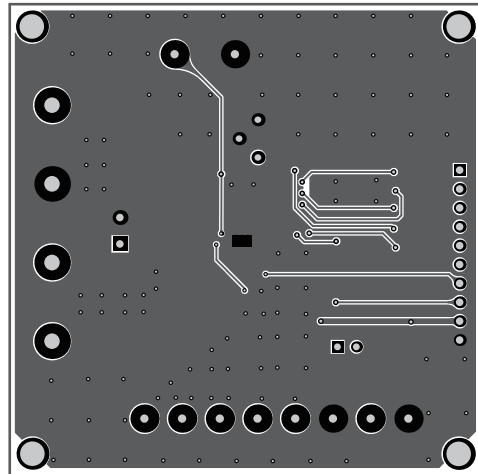

Figure 3: Bottom Layer

QUICK START GUIDE

1. Attach the input voltage ($5.4V \leq V_{IN} \leq 35V$) and input ground to the VIN and GND connectors respectively.
2. Input control and logic signal can be set either through the CN1 connector by the external MCU or through the SW1 by manual action. Manual action requires an external 3.3V or 5V Vcc voltage as a pull-up power supply. The logic truth table is shown in below:

ENBL	PHASE	BRAKE	BMODE	OUT1	OUT2	Function
1	0	X	X	L	H	<i>Reverse</i>
1	1	X	X	H	L	<i>Forward</i>
0	X	1	0	L	L	<i>Brake (low)</i>
0	X	1	1	H	H	<i>Brake (high)</i>
0	0	0	X	H*	L*	<i>Sync fast decay</i>
0	1	0	X	L*	H*	<i>Sync fast decay</i>

3. The VISEN output voltage scaling is set by the RV1 adjustable resistor.

NOTICE: The information in this document is subject to change without notice. Users should warrant and guarantee that third party Intellectual Property rights are not infringed upon when integrating MPS products into any application. MPS will not assume any legal responsibility for any said applications.