



The Future of Analog IC Technology®

EV2670DQ-00A Battery Charger Protection Circuit Evaluation Board

DESCRIPTION

The EV2670DQ-00A is an evaluation board for the MP2670. EV2670DQ-00A includes mainly two parts: MP2670 protection circuit and MP2602 charging system. The output of MP2670 is the input of MP2602.

By integrating high voltage input protection into the charger IC, the MP2670 can tolerate an input surge up to 30V.

The MP2670 features input over voltage protection (OVP), battery voltage over voltage protection (BOVP), and over charge current protection (OCP). Additionally, MP2670 also monitors its own internal temperature and provides thermal protection (OTP). The device also provides fault indication. Any protection event can be indicated by customer.

ELECTRICAL SPECIFICATION

Parameter	Symbol	Value	Units
Input Voltage	V_{IN}	5	V
Limit Current (MP2670)	I_{LIM}	500	mA
Charge Current (MP2602)	I_{CHG}	300	mA

FEATURES

- Input Surge up to 30V
- Input Over voltage protection in 1us.
- Proprietary Battery Over-Voltage Protection
- Programmable Charge Current Protection Limit Value.
- Temperature Monitoring and Protection
- Fault Indication
- Enable Input

APPLICATIONS

- Cell Phones
- MP3 Players
- Smart Phones
- PDAs
- Digital Cameras
- Desktop Chargers

"MPS" and "The Future of Analog IC Technology" are Registered Trademarks of Monolithic Power Systems, Inc.

EV2670DQ-00A EVALUATION BOARD



(6.6cm x 4.8cm x 0.9cm))

Board Number	MPS IC Number
EV2670DQ-00A	MP2670DQ

EVALUATION BOARD SCHEMATIC

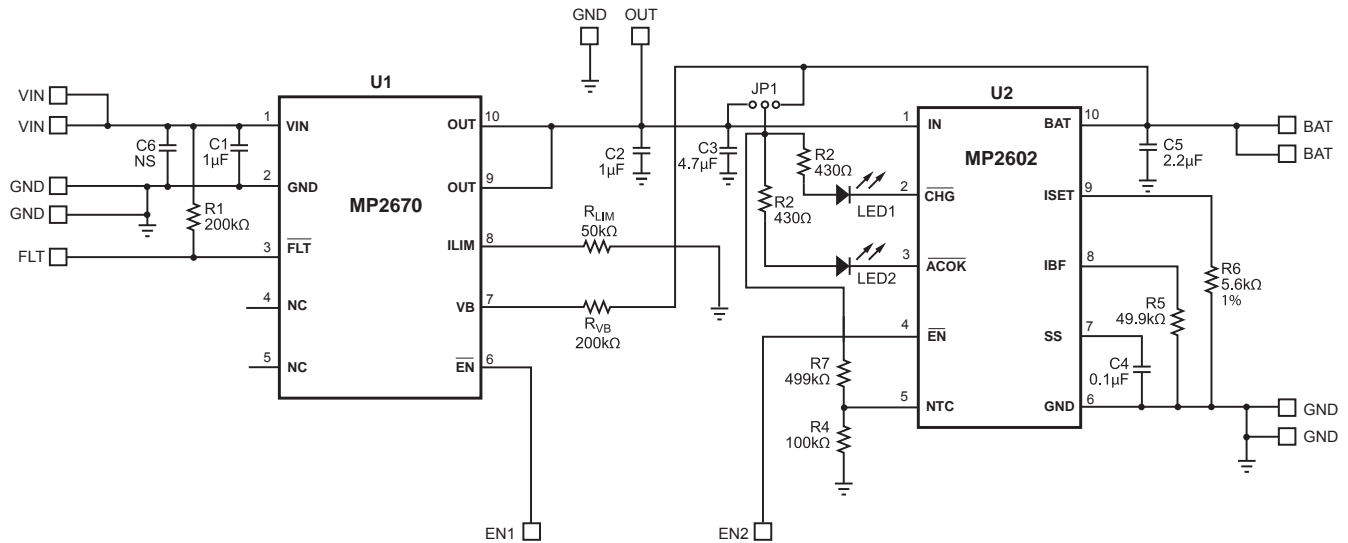

EV2670DQ-00A BILL OF MATERIALS

Qty	Ref	Value	Description	Package	Manufacturer	Manufacturer P/N
1	C1	1 μ F	Ceramic Cap., 50V, X7R	SM0805	Murata	GRM21BR71H105KA12L
1	C2	1 μ F	Ceramic Cap., 25V, X7R	SM0805	TDK	C2012X7R1E105K
1	C3	4.7 μ F	Ceramic Cap., 25V, X7R	SM1206	TDK	C3216X7R1E475K
1	C4	0.1 μ F	Ceramic Cap., 16V, X7R	SM0603	Murata	GRM188R71C104KA01D
1	C5	2.2 μ F	Ceramic Cap., 25V, X7R	SM1210	TDK	C3225X7R1E225K
1	C6	NS	Not Stuffed			
2	R1, R_VB	200k Ω	Film Res., 5%	SM0603	Yageo	RC0603JR-07200KL
2	R2, R3	430 Ω	Film Res., 5%	SM0603	Yageo	RC0603JR-07430RL
1	R4	100k Ω	Film Res., 1%	SM0603	Yageo	RC0603FR-07100KL
1	R5	49.9k Ω	Film Res., 1%	SM0603	Yageo	RC0603FR-0749K9L
1	R6	5.62k Ω	Film Res., 1%	SM0603	Yageo	RC0603FR-075K62L
1	R7	499k Ω	Film Res., 1%	SM0603	Yageo	RC0603FR-07499KL
1	R_LIM	51.1k Ω	Film Res., 1%	SM0603	Yageo	RC0603FR-0751K1L
1	LED1	CHG	LED Red, Surface Mount	SM0805	BRIGHT LED	BL-HUF35A-TRB
1	LED2	ACOK	LED Green, Surface Mount	SM0805	BRIGHT LED	BL-HGB35A-TRB
1	U1		Charge Protection Device	QFN10	MPS	MP2670DQ(FA81-9365R0-H)
1	U2		Charge Protection Device	QFN10	MPS	MP2602DQ

PRINTED CIRCUIT BOARD LAYOUT

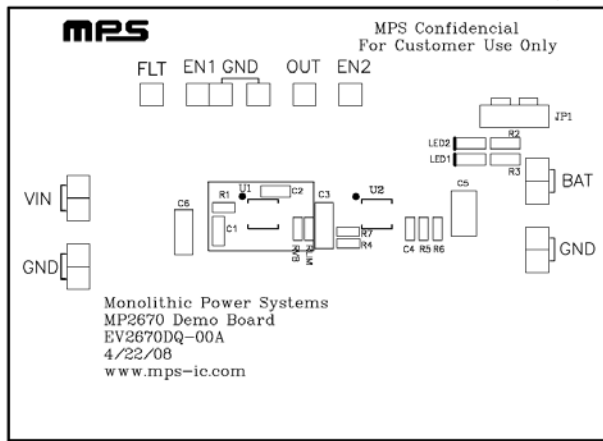

Figure 1—Top Silk Layer

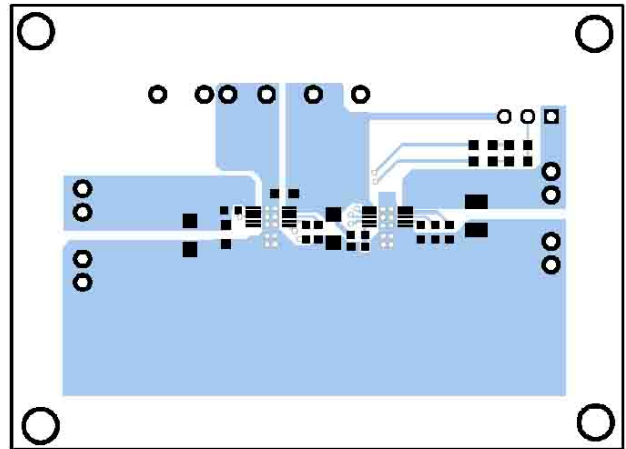

Figure 2—Top Layer

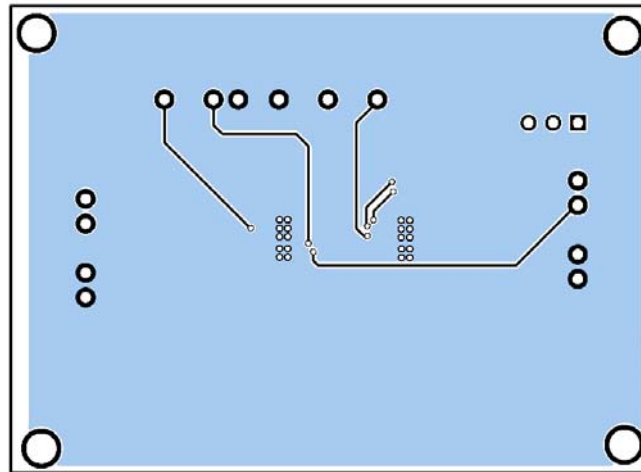

Figure 3—Bottom Layer

QUICK START GUIDE

1. The function of MP2670 can be tested without the charging circuit MP2602. The charging circuit on the board just gives a recommended layout. If it is tested with the charging circuit, MP2602 should carry a battery.
2. The board layout accommodates most commonly used capacitors and resistors.
3. Attach the positive and negative terminators of the load to the OUT and GND pins respectively.
4. Attach the input voltage (max 30V) and input ground to the VIN and GND pins respectively. It will start up when V_{IN} is higher than 3V and shut down when V_{IN} is below 2.4V.
5. MP2670 will start up automatically with floating EN1 pin.

If MP2670 is controlled by EN1, drive V_{EN1} below 0.4V to enable the IC and drive it higher than 1.5V to disable MP2670.

6. If the input voltage is higher than 6V, MP2670 will detect this input OVP fault, and drop the voltage of OUT pin down to 0V. There is no input to the charger system.
7. The battery over voltage is indicated by VB pin, if the Voltage of VB is higher than 4.4V, the voltage of OUT pin will drop to 0V too. The resistor RVB from BAT to VB pin provides a current limit, the recommended value is 200k Ω to 1M Ω .
8. The current limit function of MP2670 is to prevent charging the system with an excessive current, the OCP threshold can be set by the resistor R_{LIM} :

$$I_{LIM}(A) = \frac{0.8V}{R_{LIM}} \times 31250 = \frac{25000}{R_{LIM}(\Omega)}$$

The limit value of the board is set at 500mA.

9. FLT pin is an open drain output that indicates a LOW signal when any of the three protection events happens. So connect R1 from FLT to VIN pin, and R1 should be larger than 200k Ω to pull the fault signal low.
10. EN1 is the enable control pin of MP2670. EN2 is the enable control pin of the charger.

NOTICE: The information in this document is subject to change without notice. Please contact MPS for current specifications. Users should warrant and guarantee that third party Intellectual Property rights are not infringed upon when integrating MPS products into any application. MPS will not assume any legal responsibility for any said applications.