

DESCRIPTION

The EV26059DQ-00A is an evaluation board for the MP26059, a linear, high-performance single cell Li-Ion battery charger.

By integrating high voltage input protection into the charger IC, the MP26059 can tolerate an input surge up to 28V.

The MP26059 features constant current (CC) and constant voltage (CV) charging modes with programmable charge currents (200mA to 1A), Time out control battery full terminated control, thermal protection, battery temperature monitoring, reverse current blocking and trickle charge. The device also provides AC adapter power good and charge status indications to the system.

ELECTRICAL SPECIFICATION

Parameter	Symbol	Value	Units
Input Voltage	V_{IN}	5	V
Charge Current	I_{CHG}	0.8	A

FEATURES

- Input Surge up to 28V
- Adapter or USB Input
- Programmable Charge Current: 200mA to 1A
- Proprietary Over-Voltage Protection
- 0.75% V_{BATT} Accuracy
- Battery Temperature Monitoring
- AC Adapter Power Good Indicator
- Charge Status Indicator
- Battery full terminated control
- Timer off control
- Fully Assembled and Tested

APPLICATIONS

- Cell Phones
- MP3 Players
- Smart Phones
- PDAs
- Digital Cameras

"MPS" and "The Future of Analog IC Technology" are Registered Trademarks of Monolithic Power Systems, Inc.

EV26059DQ-00A EVALUATION BOARD



(L x W x H) 2.0" x 1.9" x 0.5"
(5.0cm x 4.8cm x 1.2cm)

Board Number	MPS IC Number
EV26059DQ-00A	MP26059DQ

I-V Charge Curve

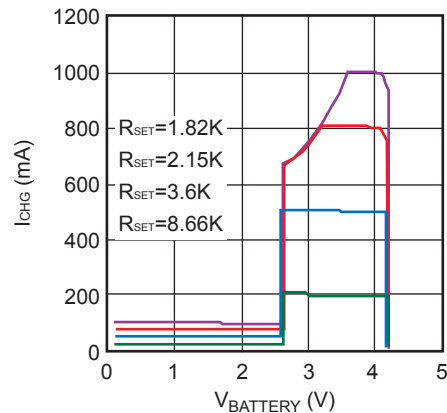

EVALUATION BOARD SCHEMATIC

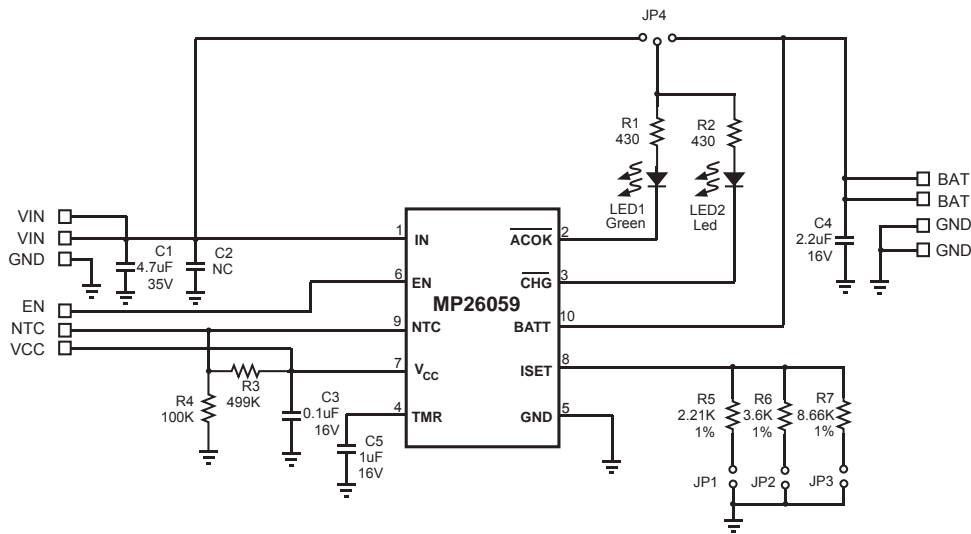

EV26059DQ-00A BILL OF MATERIALS

Qty	Ref	Value	Description	Package	Manufacturer P/N
1	C1	4.7µF	Ceramic Cap, 35V, X7R	1210	Murata: GRM32ER71H475KA88L Holystone: C1210B475M035T
1	C2	1µF	Ceramic Cap, 35V, X7R	1206	TDK: C3216X7R1H105K
1	C3	0.1µF	Ceramic Cap, 16V, X7R	0603	TDK: C1608X7R1C104K
1	C4	2.2µF	Ceramic Cap, 16V, X7R	1210	Murata: GRM32MR71C225MC01L
1	C5	1µF	Ceramic Cap, 16V,±10%,X7R	805	TDK C2012X7R1C105K
3	JP1, JP2, JP3		3x2-Pin Connector Header, 0.100"		Molex 10-89-1601
1	JP4		3-Pin Connector Header, 0.100"		Sullins: PTC03SAAN
1	LED1		Led Green, Surface Mount	0603	Lumex: SML-LX0603GW-TR
1	LED2		Led Red, Surface Mount	0603	Lumex: SML-LX0603IW-TR
2	R1, R2	430Ω	Film Resistor, 5%	0603	Panasonic: ERJ-3GEYJ431V
1	R3	499kΩ	Film Resistor, 1%	0603	Panasonic: ERJ-3EKF4993V

EV26059DQ-00A BILL OF MATERIALS *(continued)*

Qty	Ref	Value	Description	Package	Manufacturer P/N
1	R4	100k Ω	Film Resistor, 1%	0603	Panasonic: ERJ-3EKF1003V
1	R5	2.21k Ω	Film Resistor, 1%	0603	Panasonic: ERJ-3EKF211V
1	R6	3.6k Ω	Film Resistor, 1%	0603	YAGEO 9C06031A3601FKHFT
1	R7	8.66k Ω	Film Resistor, 1%	0603	Panasonic: ERJ-3EKF48661V
1	U1		Linear Charger	QFN10	MPS: MP26059DQ

PRINTED CIRCUIT BOARD LAYOUT

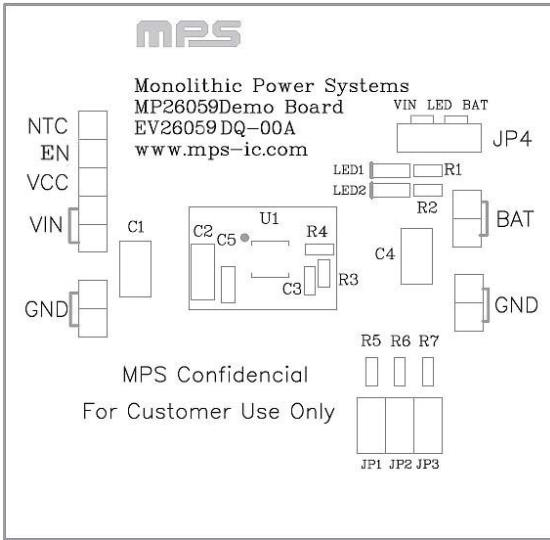

Figure 1—Top Silk Layer

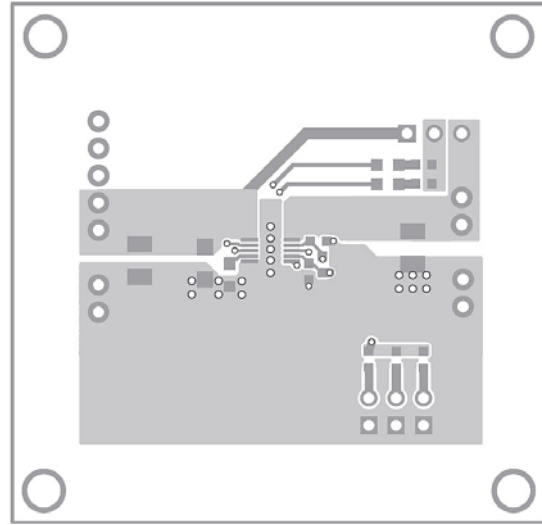

Figure 2—Top Layer

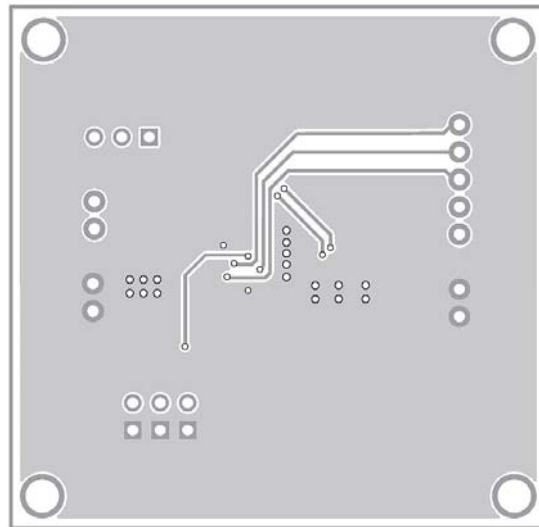

Figure 3—Bottom Layer

QUICK START GUIDE

The output voltage on this board is preset to 4.2V (for a single cell battery). The board layout accommodates most commonly used capacitors.

The LEDs are power indicators. When LED1 is on, the 5V input and Enable High (>2.8V) are present (LED1 is off when the input is disconnected). When LED2 is on, the battery is charging, and when the battery is full or there is no battery connected, LED 2 will turn off.

1. Set the charge current I_{CHG} using the jumpers JP1, JP2 and JP3 per the following table:

JP1	JP2	JP3	I_{CHG}
X		X	1000mA
X			800mA
	X	X	700mA
	X		500mA
		X	200mA

Where “X” indicates a connection.

2. Attach the positive and negative ends of the load to the VOUT and GND pins, respectively.
3. Attach the input voltage ($V_{IN}=5V$) and the input ground to the VIN and GND pins, respectively.
4. The timer cap, C5 on EVB is $1\mu F$. This will set the oscillator frequency to be 11HZ. For different oscillator frequency setting, please follow the formula:

$$F_{osc} = 5Hz \times \frac{2.2\mu F}{C_5}$$

5. Set the LED1 and LED2 input power from the VIN side or BAT side using JP4.
6. Attached the Enable Voltage (>2.8V) and the input ground to the EN and GND pins respectively.

NOTICE: The information in this document is subject to change without notice. Please contact MPS for current specifications. Users should warrant and guarantee that third party Intellectual Property rights are not infringed upon when integrating MPS products into any application. MPS will not assume any legal responsibility for any said applications.