



The Future of Analog IC Technology®

mEZD81260A

16V/60A DC/DC Open Frame Module with Integrated Inductor

PRELIMINARY SPECIFICATIONS SUBJECT TO CHANGE

DESCRIPTION

The mEZD81260A is a digital synchronous, step-down, COT control mode, open frame power module for high density DC/DC power application. It can provide 60A continuous output current.

The mEZD81260A is targeted for applications such as telecom and networking systems. It adopts digital control algorithm and can achieve fast transient response. It can be configured as dual phase or dual rail operation.

At the dual phase operation mode, the mEZD81260A has perfect interleaving and current sharing performance with proprietary digital technology used.

At the dual rail operation mode, the mEZD81260A can achieve programmable power on/off sequence.

The mEZD81260A need least external discrete components for sense and control circuit.

Almost all operation parameters and configuration parameters can be easily defined through PMBus commands with MPS digital programmable GUI.

The mEZD81260A provides full programmable fault protection features including: UVLO, UVP, OVP, OCP and OTP.

FEATURES

- Wide 5V to 16V Operating Input Range
- 2 Phases or 2 Rails Operation
- 60A Continuous Output Current
- Built-in EEPROM
- PMBus Compliant (Up to 1MHz clock)
- Pin Programmable for PMBus Address (16 addresses)
- Output Voltage Remote Sensing for Both Rails
- Switching Frequency Range 200kHz to 2MHz
- Fast Load Transient Response
- Input voltage, Output voltage and Current, Temperature Monitor
- OVP/UVP/OCP/OTP Protection
- Fault Auto Record Function
- Digital Load and Line Regulation
- Provide Ultrasonic Mode
- EEPROM Write Protection
- Available in LGA-28 (25mm x 15.5mm x 7mm)

APPLICATIONS

- Power Supplies for Memory,
- DSP, ASIC, FPGA, Microprocessor
- Servers and Storage Equipment
- Industrial / ATE
- Telecom and DATACOM Equipment

All MPS parts are lead-free, halogen free, and adhere to the RoHS directive. For MPS green status, please visit MPS website under Quality Assurance. "MPS" and "The Future of Analog IC Technology" are Registered Trademarks of Monolithic Power Systems, Inc.

TYPICAL APPLICATION

2 Rails:

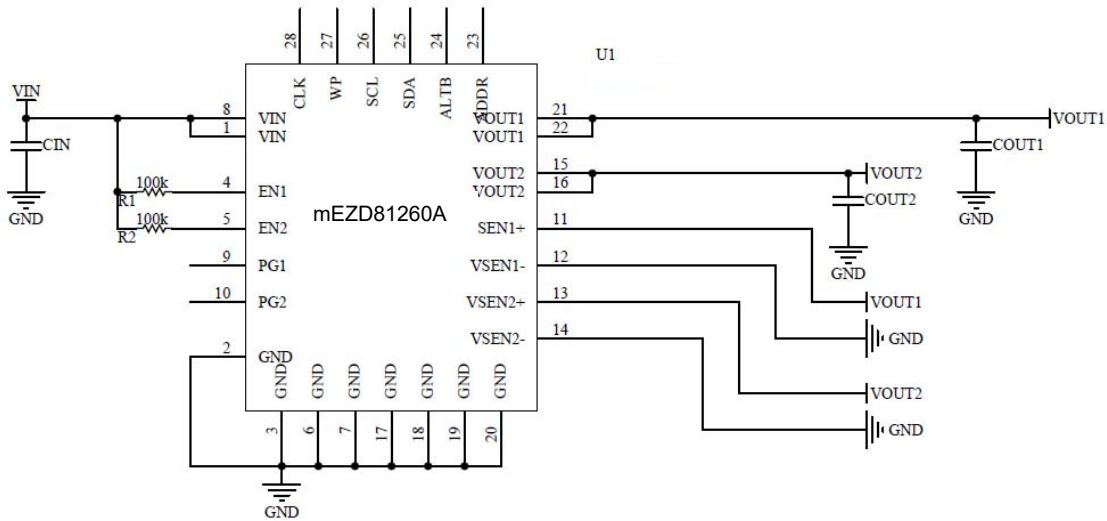

2 Phases:

