

### DESCRIPTION

The MPQ8039 is a general purpose, high frequency half bridge power driver capable of driving a 9A load. The device integrates both top and bottom N-Channel MOSFET power switches and is fully protected from both sourcing and sinking current by a preset cycle-by-cycle current limit. It has a wide input voltage range from 7.5V to 25V.

The MPQ8039 features a low-current shutdown mode, input under-voltage protection, thermal shutdown. It interfaces with standard logic signals and is available in a small SOIC8E package.

### FEATURES

- Guaranteed Industrial/Automotive Temp. Range Limits
- $\pm 9A$  Peak Current Output
- $\pm 4.25A$  Continuous Current Output
- Up to 1.2MHz Switching Frequency
- Protected Integrated Power 100m $\Omega$  Switches
- All Switches Current Limited
- Integrated Under-Voltage Protection
- Integrated Thermal Protection
- 2.5 $\mu A$  Standby Mode
- True 2-Quadrant Operation
- Sources and Sinks Current
- Available in AEC-Q100 Qualified Grade

### APPLICATIONS

- Class D Audio Driver
  - 25W/4 $\Omega$ /10% Output Power Single Ended
  - 70W/4 $\Omega$ /10% Output Power Full Bridge
- Full or Half Bridge DC-DC Switching Regulator
- Motor Driver

All MPS parts are lead-free and adhere to the RoHS directive. For MPS green status, please visit MPS website under Products, Quality Assurance page. "MPS" and "The Future of Analog IC Technology" are Trademarks of Monolithic Power Systems, Inc.

### TYPICAL APPLICATION

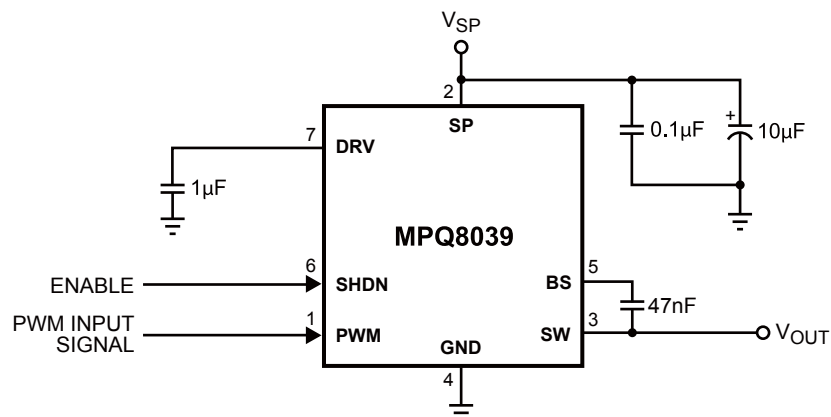

## ORDERING INFORMATION

Part Number	Package	Top Marking
MPQ8039GN*	SOIC8E	MP8039
MPQ8039GN-AEC1**	SOIC8E	MP8039

\* For Tape & Reel, add suffix –Z (eg. MPQ8039GN–Z)

\*\* For Tape & Reel, add suffix –Z (eg. MPQ8039GN-AEC1–Z)

## PACKAGE REFERENCE

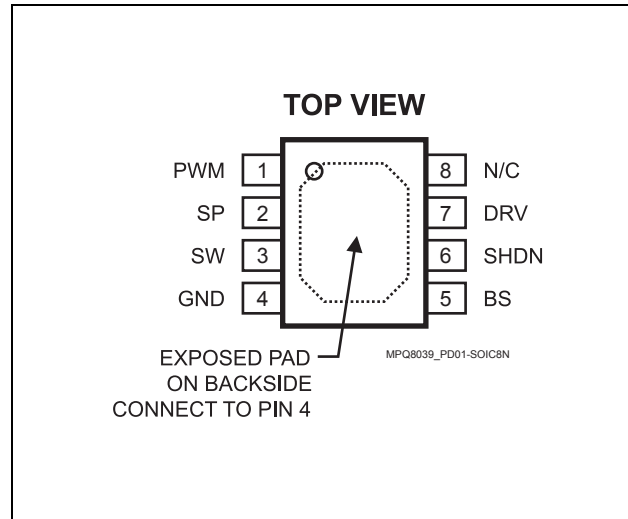

### ABSOLUTE MAXIMUM RATINGS <sup>(1)</sup>

SP Supply Voltage ( $V_{SP}$ ).....	-0.3V to +28V <sup>(5)</sup>
SW Pin Voltage.....	-0.3V to $V_{SP}$
SW to BS .....	-0.3V to +6V
Voltage at All Other Pins.....	-0.3V to +6V
Continuous Power Dissipation ( $T_A = +25^\circ\text{C}$ ) <sup>(2)</sup>	2.5W
Storage Temperature.....	-55°C to +150°C

### Recommended Operating Conditions <sup>(3)</sup>

SP Supply Voltage ( $V_{SP}$ ).....	7.5V to 24V
Peak Output Current.....	9A Maximum
Operating Junction Temp. ( $T_J$ ). .....	-40°C to +125°C

<b>Thermal Resistance <sup>(4)</sup></b>	$\theta_{JA}$	$\theta_{JC}$
SOIC8E .....	48	10 ... °C/W

Notes:

- 1) Absolute maximum ratings are rated under room temperature unless otherwise noted. Exceeding these ratings may damage the device.
- 2) The maximum allowable power dissipation is a function of the maximum junction temperature  $T_J$  (MAX), the junction-to-ambient thermal resistance  $\theta_{JA}$ , and the ambient temperature  $T_A$ . The maximum allowable continuous power dissipation at any ambient temperature is calculated by  $PD (MAX) = (T_J (MAX) - T_A) / \theta_{JA}$ . Exceeding the maximum allowable power dissipation will cause excessive die temperature, and the device will go into thermal shutdown. Internal thermal shutdown circuitry protects the device from permanent damage.
- 3) The device is not guaranteed to function outside of its operating conditions.
- 4) Measured on approximately 1" square of 1 oz copper.
- 5) For room temperature only.

## ELECTRICAL CHARACTERISTICS

$V_{SP} = 12V$ ,  $V_{SHDN} = 0V$ ,  $T_J = -40^{\circ}C$  to  $+125^{\circ}C$ , Typical value are  $T_J = 25^{\circ}C$ , unless otherwise noted.

Parameter	Symbol	Condition	Min	Typ	Max	Units
SP Operating Current				1.5	2.5	mA
SP Shutdown Current		$V_{SHDN} = 2V$		2.5	10	$\mu A$
SHDN, SP Threshold Low					1	V
SHDN, SP Threshold High			2			V
SHDN, SP Input Bias Current				1		$\mu A$
SW On Resistance		$V_{SP} = 7.5V$ , High-Side and Low-Side		0.1	0.25	$\Omega$
SW Current Limit <sup>(5)</sup>		$V_{PWM} = 5$ , (Sinking)		9		A
		$V_{PWM} = 0$ , (Sourcing)		9		A
SW Switching Frequency		$V_{PWM} = 0$ to $2V$ , 50% Duty Cycle			1.2	MHz
SW Maximum Duty Cycle <sup>(6)</sup>		$V_{SP} = 7.5V$ , $V_{PWM} = 2V$ , $C_{SW} 100nF$ , $f_{SW} = 3.3kHz$		99.5		%
SW Rise/Fall Time		$V_{PWM} = 0$ to $5V$		20		ns
PWM Pulse Width		$V_{PWM} = 0$ to $2V$ , High or Low Pulse	200			ns
PWM to SW Delay Time Rising		$V_{PWM} = 0$ to $5V$		70		ns
PWM to SW Delay Time Falling		$V_{PWM} = 5$ to $0V$		70		ns
Thermal Shutdown Temperature <sup>(5)</sup>		$T_J$ Rising, Hysteresis = $20^{\circ}C$		160		$^{\circ}C$
IN UVLO		Rising Edge	5.5		7.5	V
DRV Voltage	$V_{DRV}$	$V_{SP}=10V$	5.1	5.6	6.0	V
PWM Threshold Voltage		$V_{PWM}$ Rising			2.4	V
		$V_{PWM}$ Falling	1.3			V

**Notes:**

- 6) Not production tested.
- 7) SW drives low for  $1.5\mu s$  every  $300\mu s$  to charge the BS to SW capacitor.

### TYPICAL PERFORMANCE CHARACTERISTICS

Circuit of Figure 4,  $T_A = +25^\circ\text{C}$ , unless otherwise noted.

**Delay Time  
SW Falling ( $V_{SP}=25\text{V}$ )**

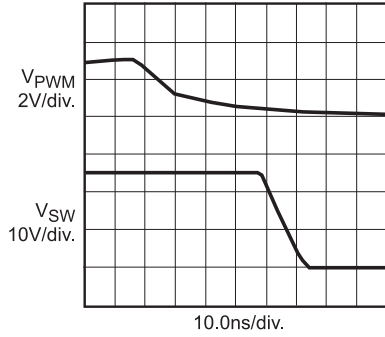

**Delay Time  
SW Rising ( $V_{SP}=25\text{V}$ )**

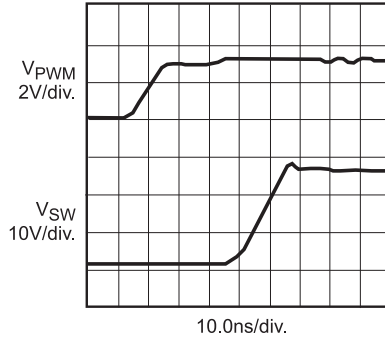

**THD+N vs Output Power**

( $V_{SP}=24\text{V}$ ) Bridged Output into  $4\Omega$   
(Class D Application using closed loop circuit)

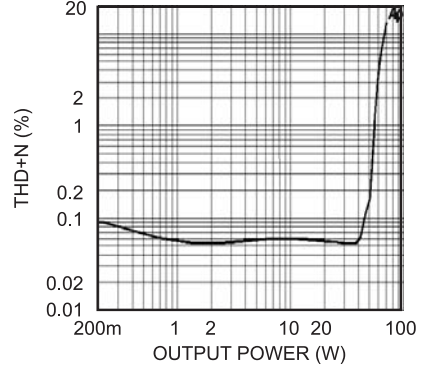

**Supply Current vs.  $T_J$**

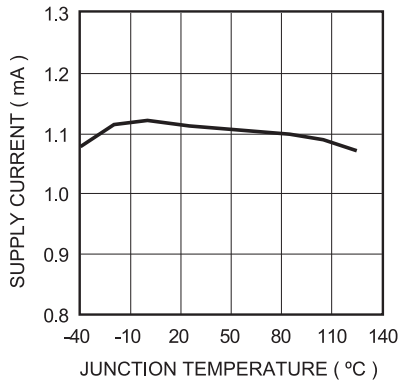

**H\_S  $R_{DS\_ON}$  vs.  $T_J$**

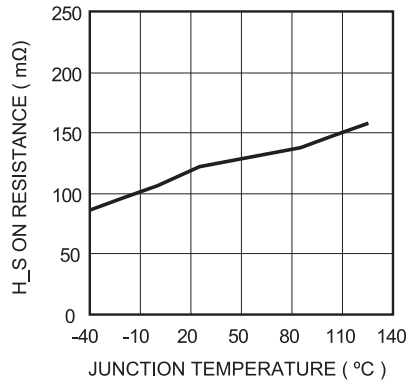

**L\_S  $R_{DS\_ON}$  vs.  $T_J$**

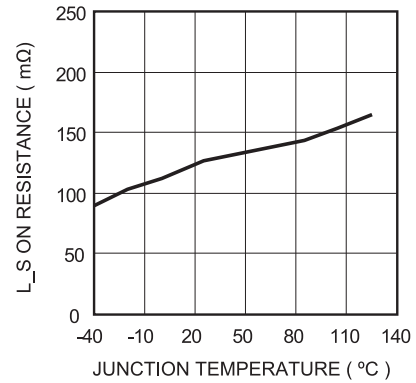

**UVLO Falling Voltage vs.  $T_J$**

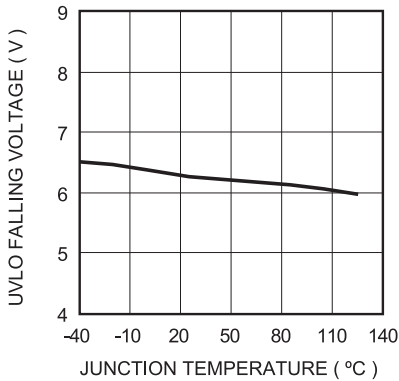

**UVLO Rising Voltage vs.  $T_J$**

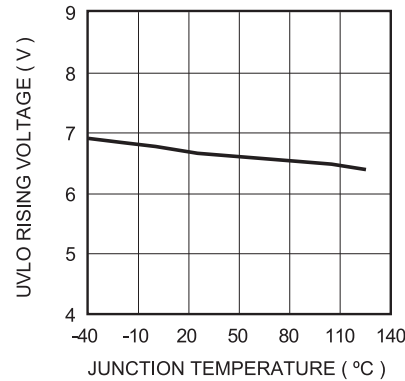

## TYPICAL PERFORMANCE CHARACTERISTICS

$V_{IN}=24V$ ,  $R_{LOAD}=4\Omega$ ,  $L=10\mu H$ ,  $F_{IN}=0.5MHz$ ,  $T_A=25^\circ C$ , Unless otherwise noted.

Steady State

$F_{IN}=0.1MHz$

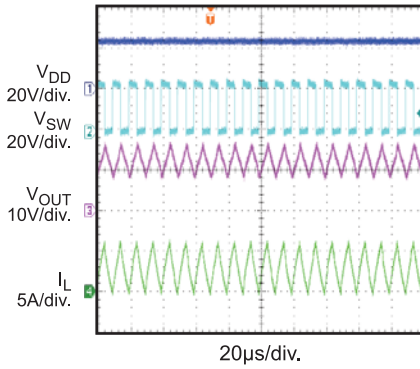

Steady State

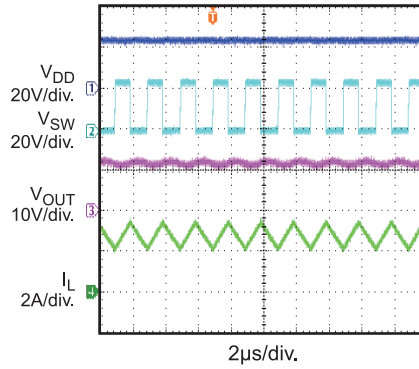

Steady State

$F_{IN}=1.2MHz$

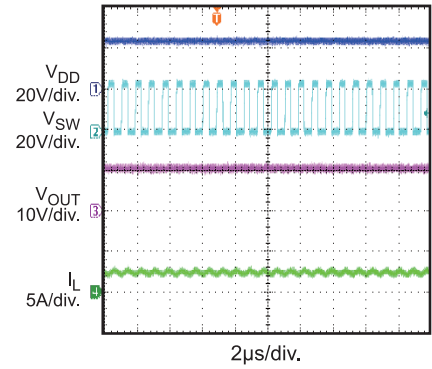

Power Ramp Up

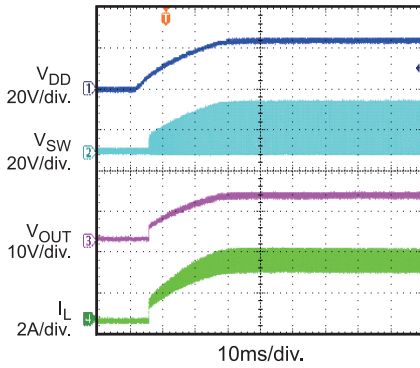

Power Ramp Down

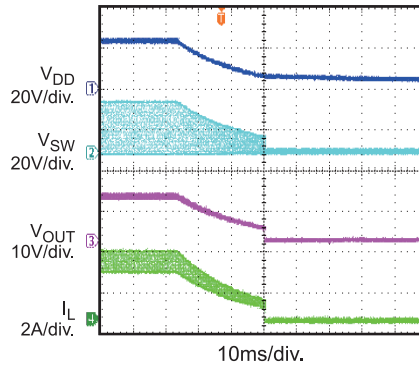

Short Output Protection

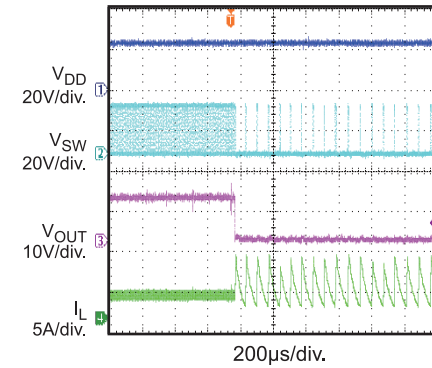

Enable On

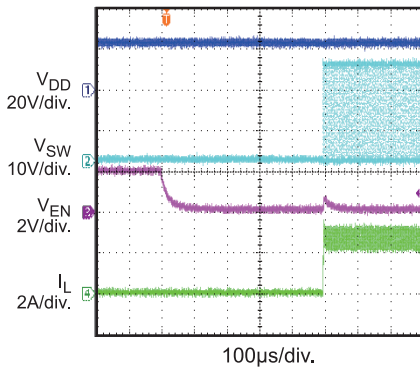

Enable Off

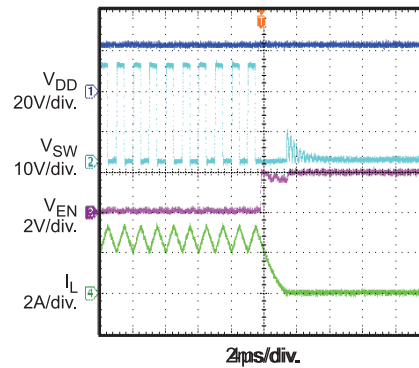

Short Output Recovery

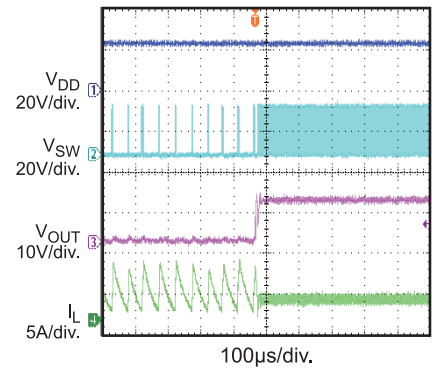

## PIN FUNCTIONS

Pin #	Name	Description
1	PWM	Driver Logic Input. Drive PWM with the signal that controls the MPQ8039 output. Drive PWM high to turn on the high-side switch; drive PWM low to turn on the low-side switch.
2	SP	Power Supply Input. Connect SP to the positive side of the input power supply. Bypass SP to GND as close to the IC as possible.
3	SW	Switched Output. SW is the power output of the MPQ8039. Connect the output LC filter to SW. SW is valid approximately 100µs after SP goes high.
4	GND	Ground. (Note: Connect the exposed pad on the bottom side to Pin 4).
5	BS	Bootstrap Supply. BS powers the high-side gate of the MPQ8039. Connect a 0.1µF or greater capacitor between BS and SW.
6	SHDN	Shutdown Input. SHDN enables/disables the MPQ8039. Drive SHDN low to turn on the MPQ8039, drive it high to turn it off. If not used, connect SHDN to GND.
7	DRV	Gate Drive Supply Bypass. The voltage at DRV is supplied from an internal regulator from SP. DRV powers the internal circuitry and internal MOSFET gate drives. Bypass DRV to GND with a 0.1µF to 10µF capacitor.
8	N/C	

## OPERATION

The MPQ8039 is a general purpose, power driver. It takes a logic input and drives a half bridge comprised of 0.1Ω high-side and low-side N-Channel MOSFET switches.

It operates at frequencies up to 1.2MHz, can accept a DC supply voltage as high as 25V, and produce peak output current as high as 9A.

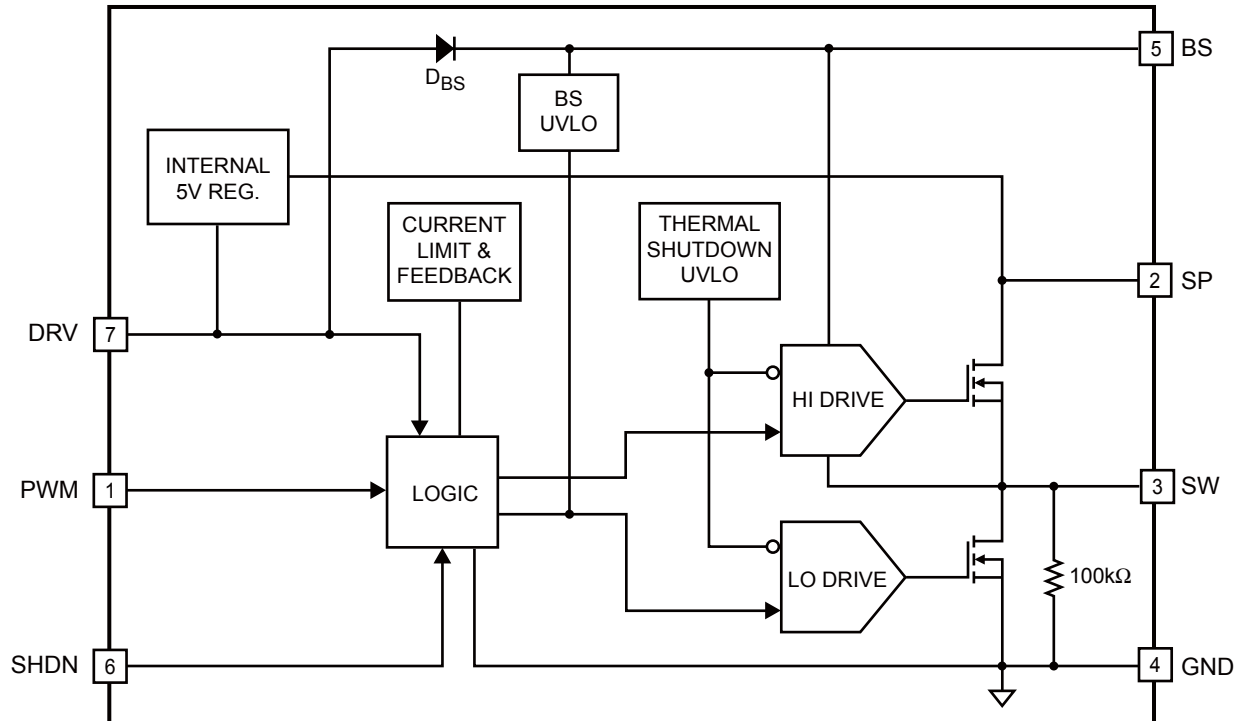

**Figure 1: Function Block Diagram**

### SW Output

The SW output drives the load. It is controlled by the logic input signal at PWM. When the signal at PWM is high (above 2V), the high-side switch is turned on. When the signal at PWM is low (less than 0.4V), the low-side switch is turned on.

The MPQ8039 uses internal N-Channel MOSFETs for both the high-side and low-side switches. The high-side MOSFET gate drive is powered from the voltage between SW and BS, allowing BS to rise above the SP input voltage to power the high-side MOSFET. To do this a bootstrap capacitor is connected between SW and BS. When the low-side switch is on, the capacitor is internally charged from the voltage at DRV, which is also internally generated. There is a dead time region (typically 40ns) where both the upper and lower switches are off (see Figure 2).

Both the high-side and low-side switches have internal current limits to prevent failure due to excessive load current. Once the current limit is reached, both output switches are turned off and the fault output is asserted (driven low).

### Shutdown

The MPQ8039 includes a 2.5μA shutdown mode. When SHDN is high, both output switches are turned off and the input current drops to 2.5μA. When the MPQ8039 is shutdown, the internally generated voltage at DRV drops to 0V. If the shutdown mode is not used, connect SHDN directly to GND.

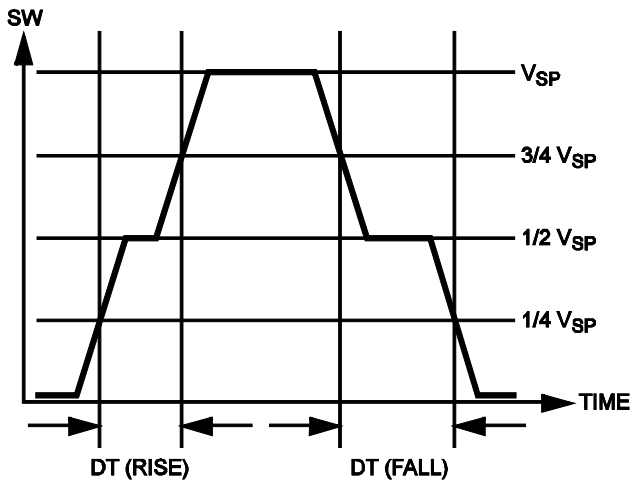

DEAD TIME RISING = 20ns  
 DEAD TIME FALLING = 40ns

Figure 2: Dead Time



## TYPICAL APPLICATION CIRCUITS

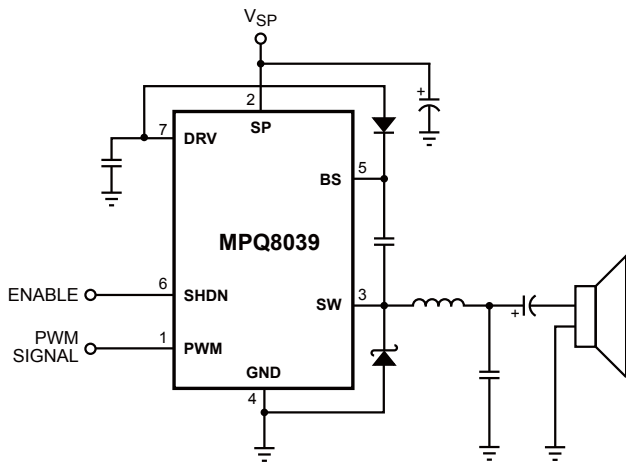

Figure 3: Single Ended Audio Amplifier

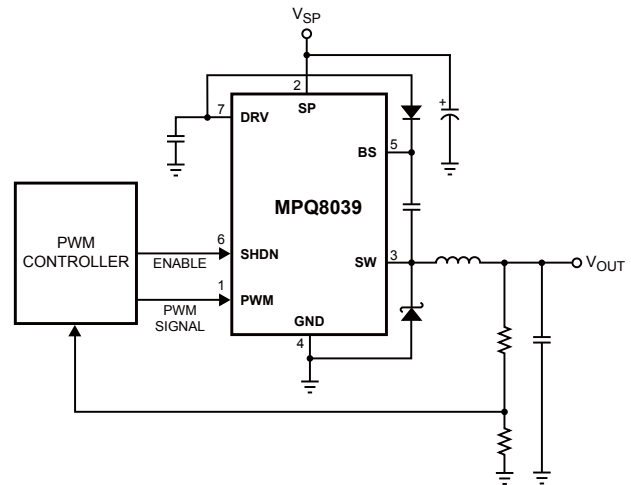

Figure 4: General Purpose DC to DC Converter

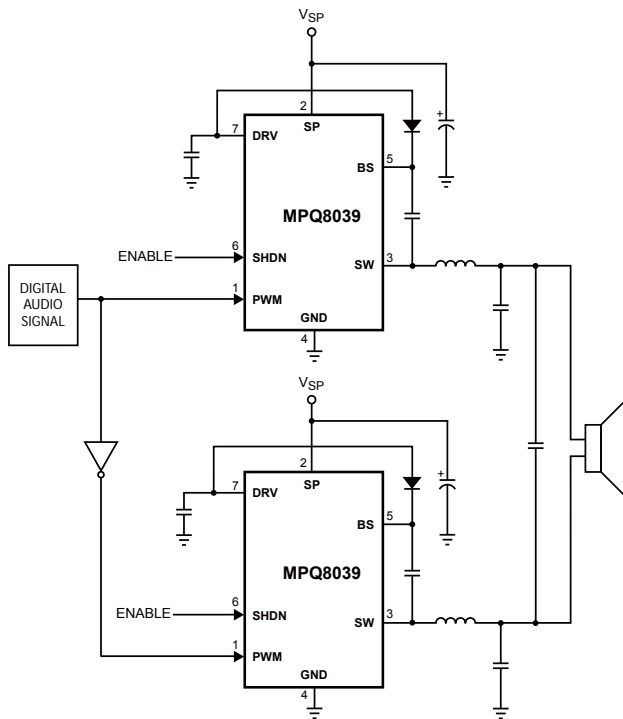

Figure 5: 80W Full Bridge Audio Amplifier

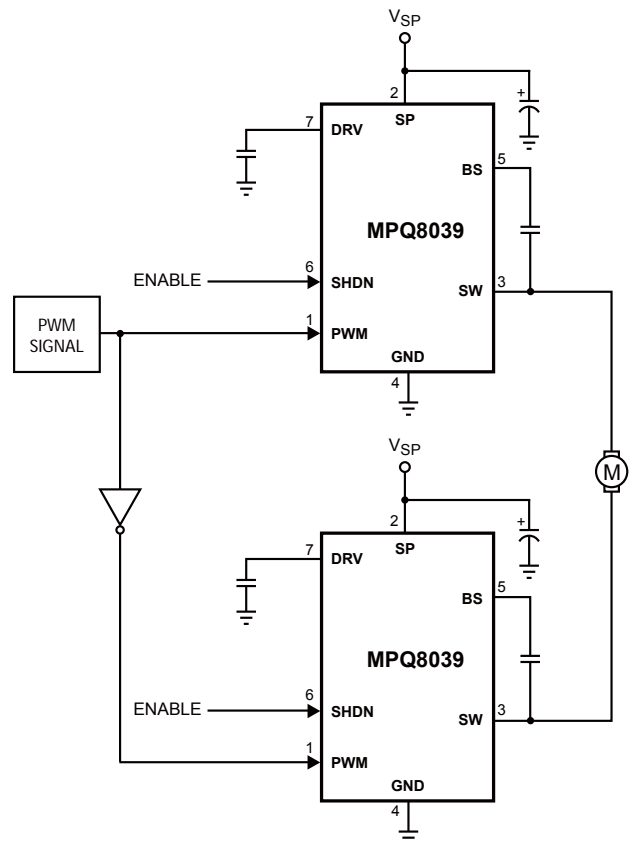

Figure 6: Full Bridge Motor Driver

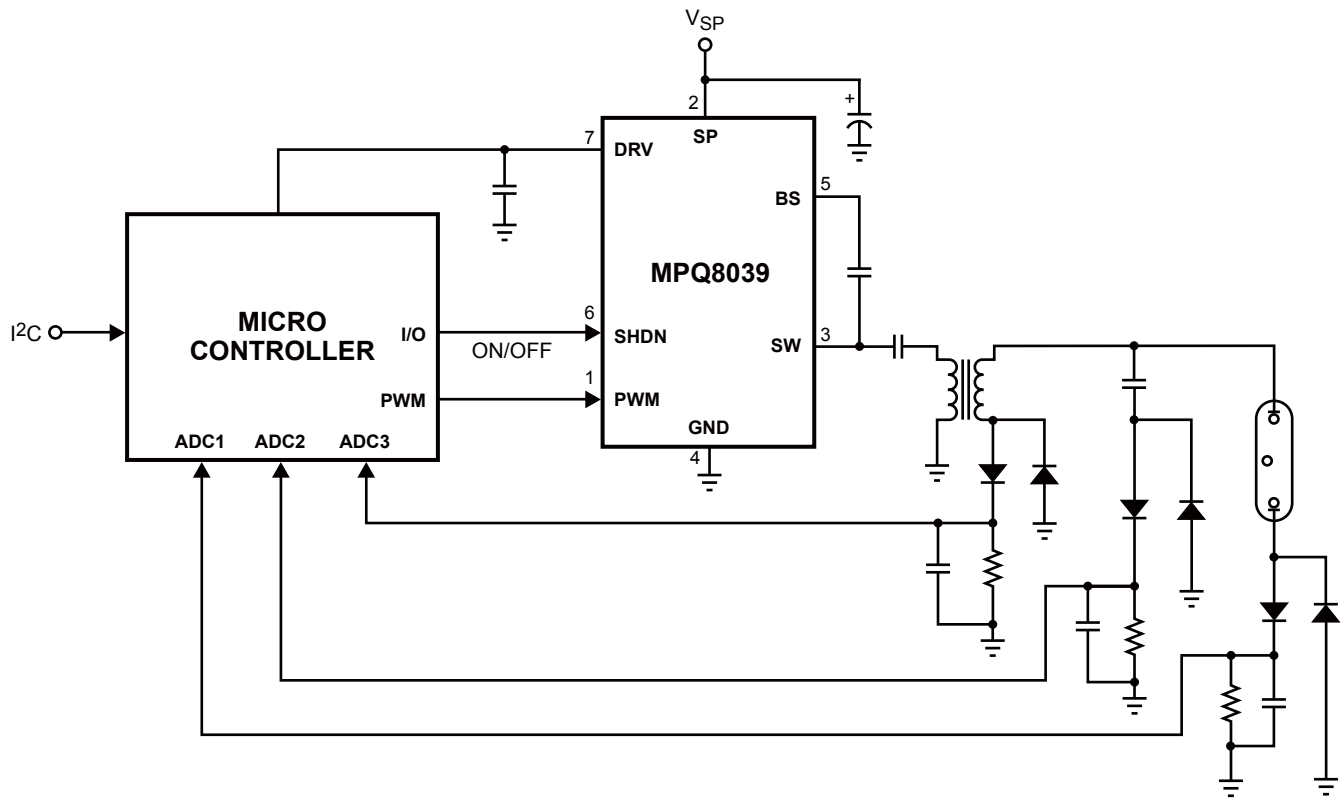
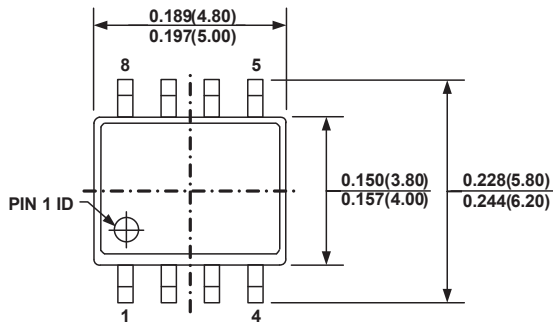

Figure 7: CCFL Driver Circuit

## PACKAGE INFORMATION

### SOIC8N (EXPOSED PAD)



**TOP VIEW**

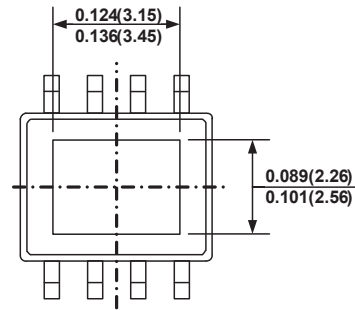

**BOTTOM VIEW**

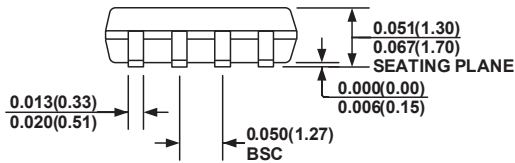

**FRONT VIEW**

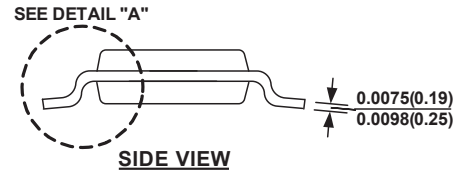

**SIDE VIEW**

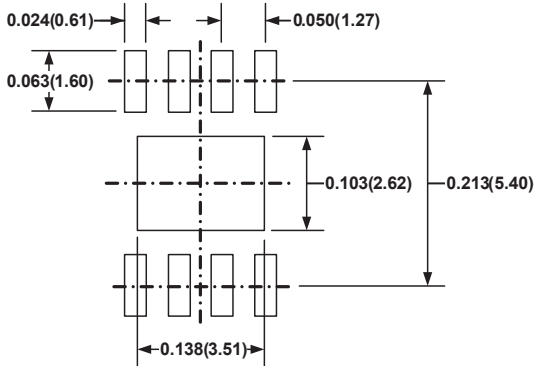

**RECOMMENDED LAND PATTERN**

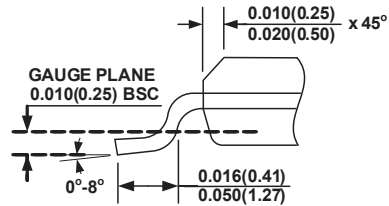

**DETAIL "A"**

**NOTICE:** The information in this document is subject to change without notice. Please contact MPS for current specifications. Users should warrant and guarantee that third party Intellectual Property rights are not infringed upon when integrating MPS products into any application. MPS will not assume any legal responsibility for any said applications.