



MPQ4328

36V, 4A, Low Quiescent Current, Synchronous Step-Down Converter, AEC-Q100 Qualified

DESCRIPTION

The MPQ4328 is a configurable-frequency (200kHz to 2.5MHz), synchronous, step-down switching converter with an integrated, internal high-side MOSFET (HS-FET) and low-side MOSFET (LS-FET). The device can achieve up to 4A of highly efficient output current (I_{OUT}) with peak current mode control.

The wide 3.3V to 36V input voltage (V_{IN}) range accommodates a variety of step-down applications in an automotive input environment. A 1 μ A quiescent current (I_Q) in shutdown mode allows the device to be used in battery-powered applications.

High power conversion efficiency across a wide load range is achieved by scaling down the switching frequency (f_{SW}) at light loads to reduce switching and gate driver losses. An open-drain power good (PG) signal indicates whether the output is within 94.5% to 105.5% of its nominal voltage.

Frequency foldback prevents inductor current (I_L) runaway during start-up. Thermal shutdown provides reliable, fault-tolerant operation. A high duty cycle and low drop-out mode are provided for automotive cold crank conditions.

The MPQ4328 is available in a QFN-14 (4mmx4mm) package.

FEATURES

- Designed for Automotive Applications
 - 42V Load Dump Tolerance
 - Up to 36V Operating Input Voltage (V_{IN})
 - Up to 4A Continuous Output Current (I_{OUT})
 - Low-Dropout Mode
 - 50ns Minimum On Time (t_{ON_MIN})
 - -40°C to +150°C Operating Junction Temperature (T_J)
 - Available in AEC-Q100 Grade 1
- Increases Battery Life
 - 1 μ A Low Shutdown Supply Current
 - 24 μ A Quiescent Current (I_Q) in Sleep Mode

FEATURES (continued)

- 28 μ A I_Q with Switching
- Advanced Asynchronous Modulation (AAM) Mode Increases Efficiency at Light Loads
- High Performance for Improved Thermals
 - Internal 45m Ω High-Side and 25m Ω Low-Side MOSFETs
- Optimized for EMC/EMI Reduction
 - 200kHz to 2.5MHz Configurable Switching Frequency (f_{SW})
 - Frequency Spread Spectrum (FSS) Modulation
 - Symmetric VIN Pinout
 - CISPR25 Class 5 Compliant
 - MeshConnect™ Flip-Chip Package
- Additional Features
 - Fixed Output Options ⁽¹⁾: 1V, 1.8V, 2.5V, 3V, 3.3V, 3.8V, or 5V
 - Power Good (PG) Output
 - Synchronizable to External Clock
 - Over-Current Protection (OCP) with Hiccup Mode
 - Available in a QFN-14 (4mmx4mm) Package with Wettable Flanks
- Functional Safety System Design Capability
 - Documents Available for MPSafe™ QM System Design



Note:

1) See the Ordering Information section on page 3 regarding the fixed-output versions. Additional output voltages may be available. Contact MPS for details.

APPLICATIONS

- Automotive Infotainment Systems
- Automotive Clusters
- Advanced Driver-Assistance Systems (ADAS)
- Industrial Power Systems

All MPS parts are lead-free, halogen-free, and adhere to the RoHS directive. For MPS green status, please visit the MPS website under Quality Assurance. "MPS", the MPS logo, and "Simple, Easy Solutions" are trademarks of Monolithic Power Systems, Inc. or its subsidiaries.

TYPICAL APPLICATION

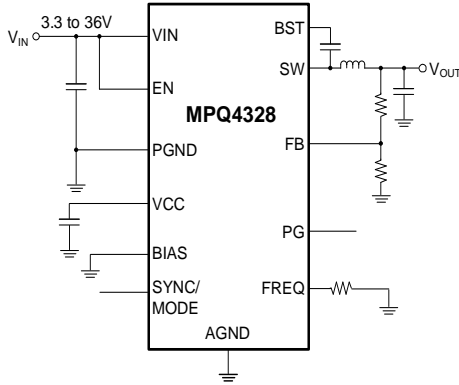

Figure 1: Typical Application (Adjustable Output)

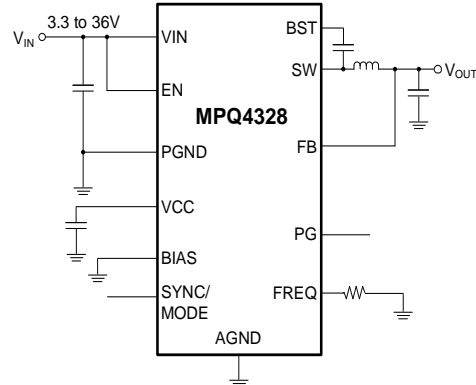
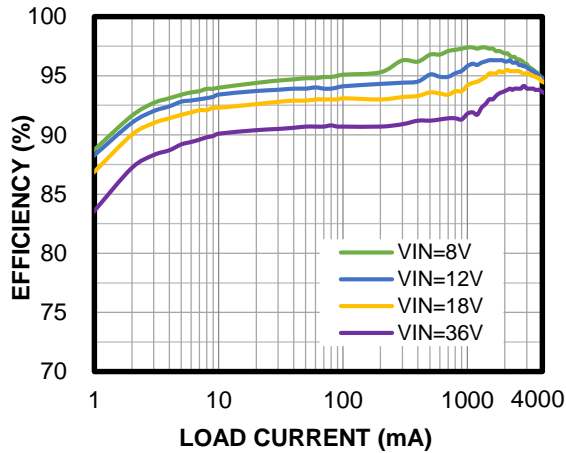

Figure 2: Typical Application (Fixed Output)

Efficiency vs. Load Current

$V_{OUT} = 5V$, $f_{SW} = 410kHz$, $L = 4.7\mu H$
(DCR = 15m Ω), AAM mode



Efficiency vs. Load Current

$V_{OUT} = 5V$, $f_{SW} = 2.2MHz$, $L = 1\mu H$
(DCR = 9.4m Ω), AAM mode

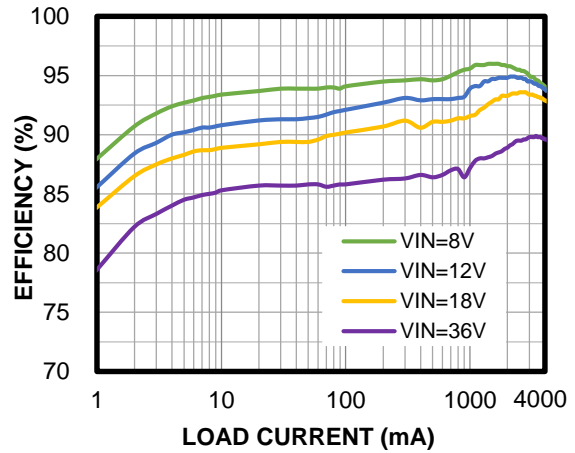

ORDERING INFORMATION

Part Number* (2)	Package	Top Marking	MSL Rating**
MPQ4328GRE-AEC1***	QFN-14 (4mmx4mm)	<i>See Below</i>	<i>Level 1</i>
MPQ4328GRE-5-AEC1***	QFN-14 (4mmx4mm)	<i>See Below</i>	<i>Level 1</i>

* For Tape & Reel, add suffix -Z (e.g. MPQ4328GRE-AEC1-Z).

** Moisture Sensitivity Level Rating

*** Wettable flank

Note:

2) Contact MPS for additional details on the fixed-output versions.

TOP MARKING

MPSYWW
MP4328
LLLLLL
E

MPS: MPS prefix
 Y: Year code
 WW: Week code
 MP4328: Part number
 LLLLLL: Lot number
 E: Wettable flank

PACKAGE REFERENCE

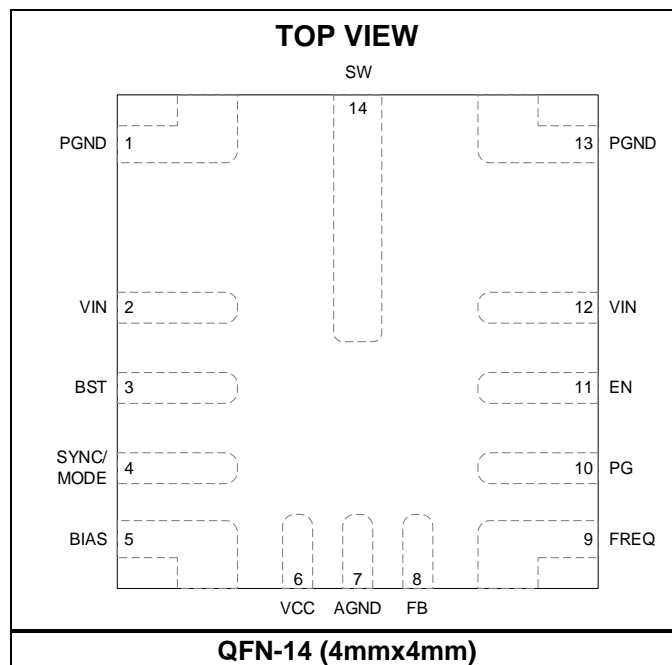

PIN FUNCTIONS

Pin #	Name	Description
1, 13	PGND	Power ground.
2, 12	VIN	Input supply. The VIN pin supplies power to all the internal control circuitry and the power MOSFET connected to SW. The two VIN pins are connected internally. Place decoupling capacitors from VIN to ground to minimize the input voltage ripple (ΔV_{IN}) and switching spikes. Place these capacitors close to each VIN pin.
3	BST	Bootstrap. The BST pin is the positive power supply for the high-side MOSFET (HS-FET) driver connected to SW. Connect a bypass capacitor between the BST and SW pins. See the Application Information section on page 38 to calculate the size of this capacitor.
4	SYNC/MODE	SYNC input and mode selection. Pulling the SYNC/MODE pin below the specified threshold (0.4V) to enter advanced asynchronous modulation (AAM) mode; pull SYNC/MODE above the specified threshold (1.4V) to enter forced continuous conduction mode (FCCM). Connect SYNC/MODE to an external 200kHz to 2.5MHz clock source to synchronize the converter to the external clock and enter FCCM. This pin has an internal, 100k Ω pull-down resistor. If SYNC/MODE is floated, the device operates in AAM mode.
5	BIAS	External bias. Connect the BIAS pin to a 5V output voltage (V_{OUT}) supply to achieve lower quiescent current (I_q). For the 5V output version, connect BIAS to V_{OUT} directly. For other output versions, connect BIAS to an external 5V source or ground. It is recommended to avoid providing an external bias voltage before V_{IN} . Do not float this pin.
6	VCC	Internal bias supply. The VCC pin is the output of the internal regulator that supplies power to the internal control circuitry and gate drivers. VCC is typically 5V. Place a >1 μ F decoupling capacitor between VCC and ground. Place this capacitor as close to VCC as possible.
7	AGND	Analog ground.
8	FB	Feedback input. For the fixed-output versions, connect the FB pin directly to V_{OUT} . For the adjustable-output version, connect FB to the middle point of the external feedback divider between the output and AGND to set V_{OUT} . The feedback (FB) threshold is 0.8V. Place the resistor divider as close to FB as possible. Avoid placing vias on the FB traces.
9	FREQ	Switching frequency configuration. Connect a resistor from the FREQ pin to ground to set the switching frequency (f_{sw}).
10	PG	Power good output. The PG pin is an open-drain output. If PG is used, connect a pull-up resistor to the power source. If V_{OUT} is within 94.5% to 105.5% of the nominal voltage, PG is pulled high. If V_{OUT} is above 107% or below 93% of the nominal voltage, PG is pulled low. Float the pin if not used.
11	EN	Enable. Pull the EN pin below the specified threshold (0.85V) to turn the converter off; pull EN above the specified threshold (1.02V) to turn it on. Do not float this pin.
14	SW	Switch node. The SW pin is the source of the HS-FET and the drain of the low-side MOSFET (LS-FET).

ABSOLUTE MAXIMUM RATINGS ⁽³⁾

VIN, EN.....	-0.3V to +40V
VIN, EN.....	42V for automotive load dump ⁽⁴⁾
SW.....	-0.3V to V _{IN_MAX} + 0.3V
BST.....	V _{SW} + 5.5V
FREQ.....	-0.3V to +5.5V
All other pins.....	-0.3V to +6V
Continuous power dissipation (T _A = 25°C) ⁽⁵⁾ ⁽⁹⁾	
QFN-14 (4mmx4mm)	4.86W
Junction temperature (T _J).....	150°C
Lead temperature.....	260°C
Storage temperature.....	-65°C to +150°C

ESD Ratings

Human body model (HBM).....	Class 2 ⁽⁶⁾
Charged-device model (CDM).....	Class C2b ⁽⁷⁾

Recommended Operating Conditions

Continuous input voltage (V _{IN}).....	3.3V to 36V
Output voltage (V _{OUT}).....	0.8V to 0.95 x V _{IN}
Operating junction temp (T _J)....	-40°C to +150°C

Thermal Resistance	θ_{JA}	θ_{JC}
QFN-14 (4mmx4mm)		
JESD51-7.....	46.7.....	7.9.....°C/W ⁽⁸⁾
EVQ4328-R-00A.....	25.7.....	°C/W ⁽⁹⁾
		Ψ_{JT}
QFN-14 (4mmx4mm)		
JESD51-7		2.6.....°C/W ⁽⁸⁾
EVQ4328-R-00A		2.2.....°C/W ⁽⁹⁾

Notes:

- 3) Absolute maximum ratings are rated under room temperature unless otherwise noted. Exceeding these ratings may damage the device.
- 4) Refer to ISO16750.
- 5) The maximum allowable power dissipation is a function of the maximum junction temperature, T_J (MAX), the junction-to-ambient thermal resistance, θ_{JA} , and the ambient temperature, T_A. The maximum allowable continuous power dissipation at any ambient temperature is calculated by P_D (MAX) = (T_J (MAX) - T_A) / θ_{JA} . Exceeding the maximum allowable power dissipation can cause an excessive die temperature, which may cause the converter to go into thermal shutdown. Internal thermal shutdown circuitry protects the device from permanent damage.
- 6) Per AEC-Q100-002.
- 7) Per AEC-Q100-011.
- 8) Measured on a JESD51-7, 4-layer PCB. The values given in this table are only valid for comparison with other packages and cannot be used for design purposes. These values were calculated in accordance with JESD51-7, and simulated on a specified JEDEC board. They do not represent the performance obtained in an actual application. The θ_{JC} value shows the thermal resistance from the junction-to-case bottom, and the Ψ_{JT} value shows the characterization parameter from the junction-to-case top.
- 9) Measured on an MPS standard EVB, 2oz. copper thickness, 4-layer PCB (8.3cmx8.3cm). The Ψ_{JT} value shows the characterization parameter from junction-to-case top.

ELECTRICAL CHARACTERISTICS

$V_{IN} = 12V$, $V_{EN} = 2V$, $T_J = -40^{\circ}C$ to $+150^{\circ}C$, typical values are at $T_J = 25^{\circ}C$, unless otherwise noted.

Parameter	Symbol	Condition	Min	Typ	Max	Units
Input Supply						
Minimum operating input voltage (V_{IN})	V_{IN_MIN}				3.3	V
V_{IN} under-voltage lockout (UVLO) rising threshold	$V_{IN_UVLO_RISING}$		3.5	3.7	3.9	V
V_{IN} UVLO falling threshold	$V_{IN_UVLO_FALLING}$		2.75	2.9	3.15	V
V_{IN} UVLO hysteresis	$V_{IN_UVLO_HYS}$			750		mV
VIN quiescent current	I_Q	$V_{FB} = 0.85V$, no load, sleep mode, without BIAS connection, $T_J = 25^{\circ}C$		24	35	μA
		$V_{FB} = 0.85V$, no load, sleep mode, without BIAS connection, $T_J = -40^{\circ}C$ to $+150^{\circ}C$		24	80	μA
		$V_{FB} = 0.85V$, no load, connect BIAS to 5V		3		μA
VIN quiescent current (switching)	I_{Q_Sleep}	SYNC/MODE is pulled to ground, AAM mode, switching, no load		28		μA
VIN active current (no switching)	I_{Q_Active}	SYNC/MODE is pulled to VCC, FCCM, no switching		950		μA
VIN shutdown current	I_{SD}	$V_{EN} = 0V$		1	10	μA
VIN over-voltage protection (OVP) rising threshold	$V_{IN_OVP_RISING}$		36	38	40	V
VIN OVP hysteresis	$V_{IN_OVP_HYS}$			1		V
MOSFETs and Frequency						
Switching frequency	f_{SW}	$R_{FREQ} = 49.9k\Omega$	350	410	460	kHz
		$R_{FREQ} = 19.6k\Omega$	900	1000	1100	kHz
		$R_{FREQ} = 8.66k\Omega$	1980	2200	2420	kHz
Minimum on time ⁽¹⁰⁾	t_{ON_MIN}			50	65	ns
Minimum off time ⁽¹⁰⁾	t_{OFF_MIN}			40	55	ns
Switch leakage current	I_{SW_LKG}	$T_J = 25^{\circ}C$		0.01	1	μA
		$T_J = -40^{\circ}C$ to $+150^{\circ}C$		0.01	5	μA
High-side MOSFET (HS-FET) on resistance	$R_{DS(ON)_HS}$	$V_{BST} - V_{SW} = 5V$		45		m Ω
Low-side MOSFET (LS-FET) on resistance	$R_{DS(ON)_LS}$	$V_{CC} = 5V$		25		m Ω
BIAS						
BIAS voltage (V_{BIAS}) takeover rising threshold	V_{BIAS_RISING}			4.6		V
V_{BIAS} takeover hysteresis	V_{BIAS_HYS}			240		mV

ELECTRICAL CHARACTERISTICS (continued)
 $V_{IN} = 12V$, $V_{EN} = 2V$, $T_J = -40^{\circ}C$ to $+150^{\circ}C$, typical values are at $T_J = 25^{\circ}C$, unless otherwise noted.

Parameter	Symbol	Condition	Min	Typ	Max	Units
Output and Regulation						
Feedback (FB) voltage	V_{FB}	$T_J = 25^{\circ}C$	794	800	806	mV
		$T_J = -40^{\circ}C$ to $+150^{\circ}C$	790	800	810	mV
FB input current	I_{FB}			0	100	nA
Output voltage (V_{OUT}) discharge current	$I_{DISCHARGE}$	$V_{EN} = 0V$, $V_{OUT} = 0.3V$	2			mA
Bootstrap (BST)						
BST to SW refresh rising threshold	V_{BST-SW_RISING}		2.2	2.7	3.2	V
BST to SW refresh falling threshold	$V_{BST-SW_FALLING}$		2	2.5	3	V
BST to SW refresh hysteresis	V_{BST-SW_HYS}			0.2		V
Enable (EN)						
EN rising threshold	V_{EN_RISING}		0.97	1.02	1.07	V
EN falling threshold	$V_{EN_FALLING}$		0.8	0.85	0.9	V
EN hysteresis voltage	V_{EN_HYS}			170		mV
Soft Start (SS) and VCC						
Soft-start time	t_{SS}	EN high to PG high	4.5	6	7.5	ms
VCC voltage	V_{CC}	$I_{VCC} = 0mA$	4.7	5	5.3	V
VCC regulation		$I_{VCC} = 30mA$, AAM mode		1		%
VCC current limit (I_{LIMIT})	I_{LIMIT_VCC}	$V_{CC} = 4V$	50	65		mA
SYNC/MODE						
SYNC/MODE voltage rising threshold	V_{SYNC_RISING}		1.4			V
SYNC/MODE voltage falling threshold	$V_{SYNC_FALLING}$				0.4	V
SYNC/MODE timeout	t_{MODE}	SYNC/MODE low to discontinuous conduction mode (DCM)		55	80	us
SYNC clock range	f_{SYNC}	% of freerunning frequency	90		110	% of f_{sw}
SYNC clock locking time	t_{SYNC_LOCK}	SYNC clock locking time			128	cycle
SYNC clock duty	D_{SYNC_DUTY}	SYNC clock duty for min input clock pulse width >40ns	20		80	%
f_{sw} after SYNC		f_{sw} accuracy compared to f_{SYNC}	-5		+5	%

ELECTRICAL CHARACTERISTICS (continued)
V_{IN} = 12V, V_{EN} = 2V, T_J = -40°C to +150°C, typical values are at T_J = 25°C, unless otherwise noted.

Parameter	Symbol	Condition	Min	Typ	Max	Units
Power Good (PG)						
PG rising threshold	V _{PG_RISING}	V _{OUT} rising	93	94.5	96	% of V _{REF}
		V _{OUT} falling	104	105.5	107	% of V _{REF}
PG falling threshold	V _{PG_FALLING}	V _{OUT} falling	91.5	93	94.5	% of V _{REF}
		V _{OUT} rising	105.5	107	108.5	% of V _{REF}
PG trip threshold hysteresis	V _{PG_HYS}			1.5		% of V _{REF}
PG low output voltage	V _{PG_LOW}	I _{SINK} = 1mA		0.1	0.3	V
PG start-up rising delay	t _{PG_RISING_DELAY}			1.2		ms
PG rising deglitch	t _{PG_RISING_DEGLITCH}			160		μs
PG falling deglitch	t _{PG_FALLING_DEGLITCH}			160		μs
Protections						
High-side (HS) I _{LIMIT}	I _{LIMIT_HS}	Duty cycle = 30%	5.5	7.5	9.5	A
Low-side (LS) valley I _{LIMIT}	I _{LIMIT_LS}		4	5	6.8	A
Zero-current detection (ZCD) current	I _{ZCD}	AAM mode	0	200		mA
LS reverse current limit	I _{LIMIT_REVERSE}	FCCM		3		A
Thermal shutdown ⁽¹⁰⁾	T _{SD}		155	170	185	°C
Thermal shutdown hysteresis ⁽¹⁰⁾	T _{SD_HYS}			20		°C

Note:

10) Guaranteed by design and characterization. Not tested in production.

TYPICAL CHARACTERISTICS

$V_{IN} = 12V$, $T_J = -40^{\circ}C$ to $+150^{\circ}C$, unless otherwise noted.

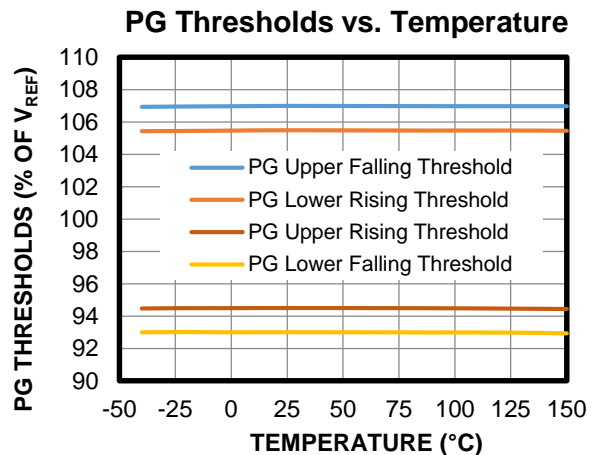
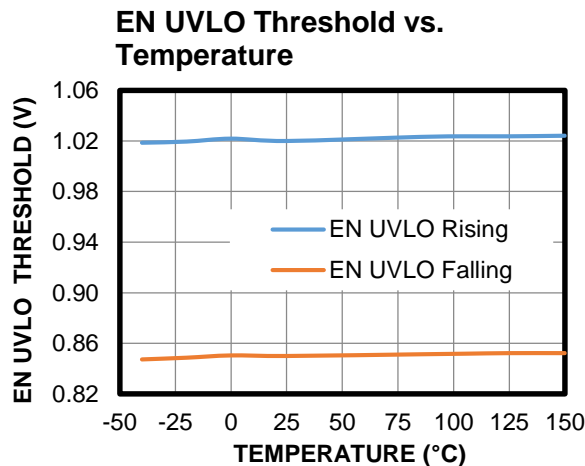
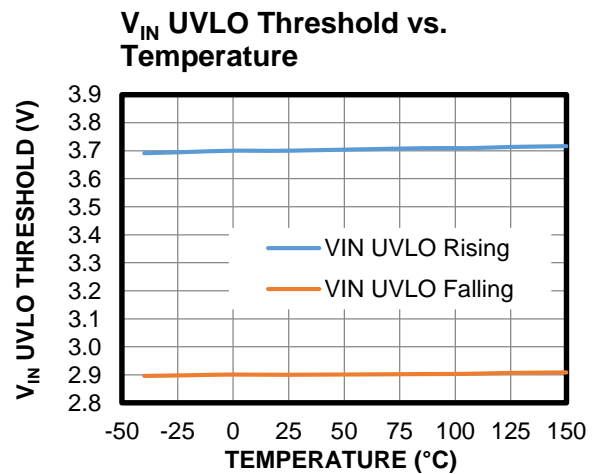
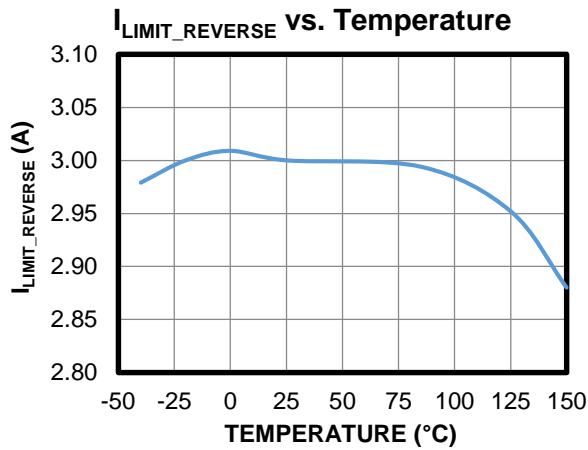
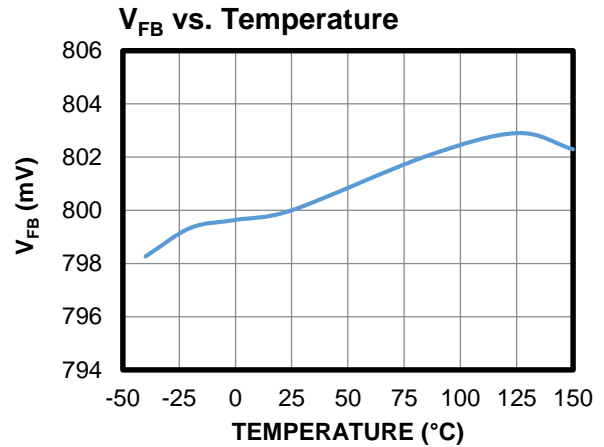
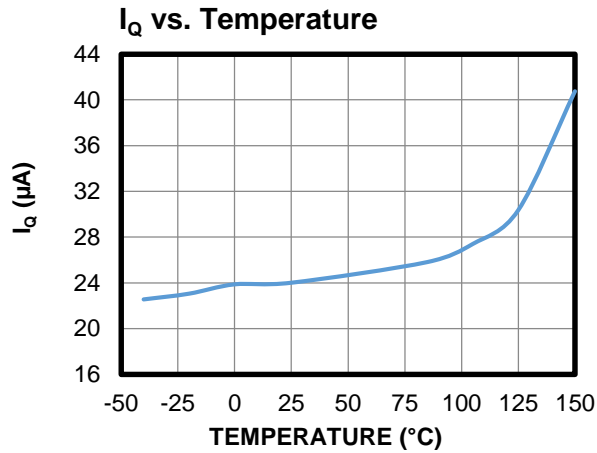

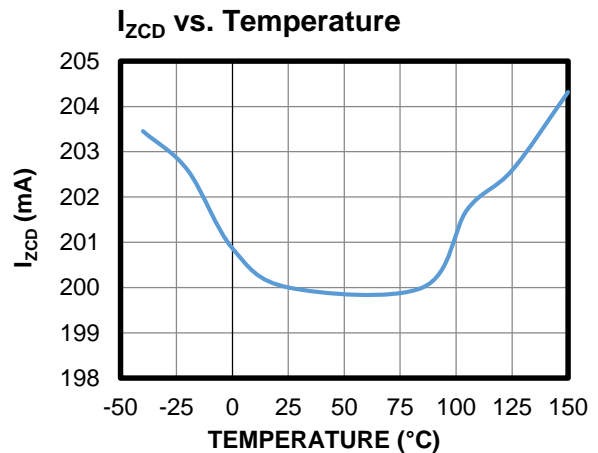
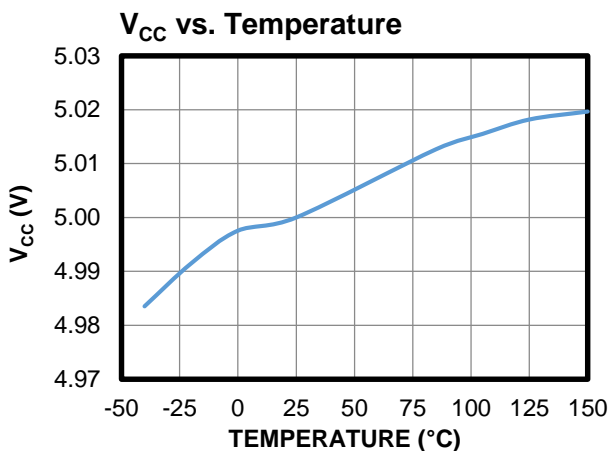
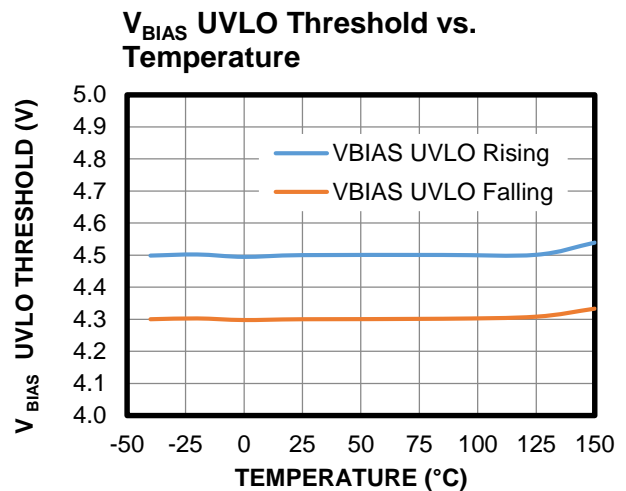
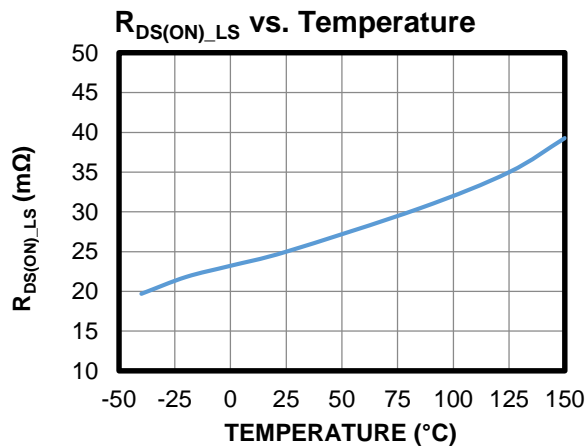
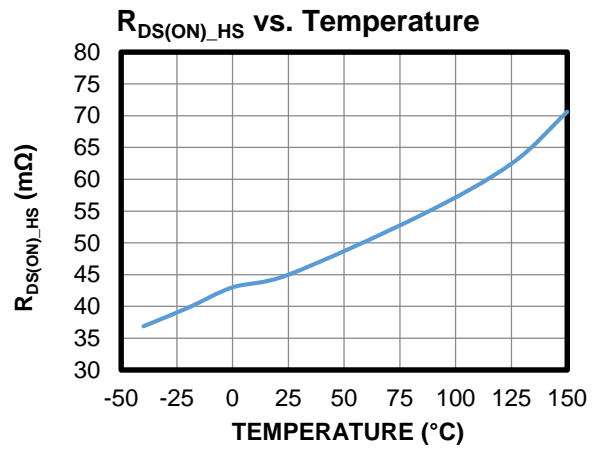
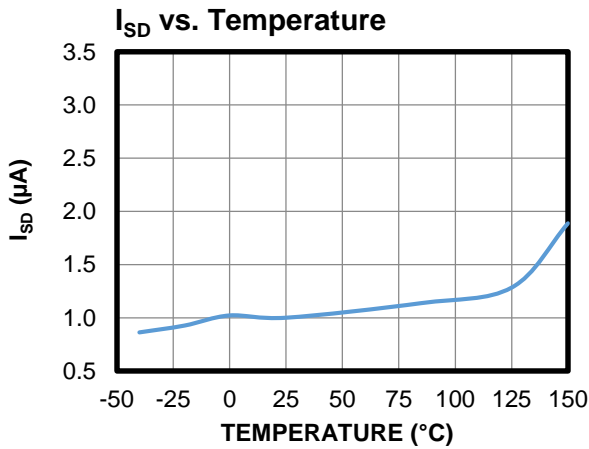
TYPICAL CHARACTERISTICS (continued)
 $V_{IN} = 12V$, $T_J = -40^{\circ}C$ to $+150^{\circ}C$, unless otherwise noted.

TYPICAL CHARACTERISTICS (continued)

V_{IN} = 12V, T_J = -40°C to +150°C, unless otherwise noted.

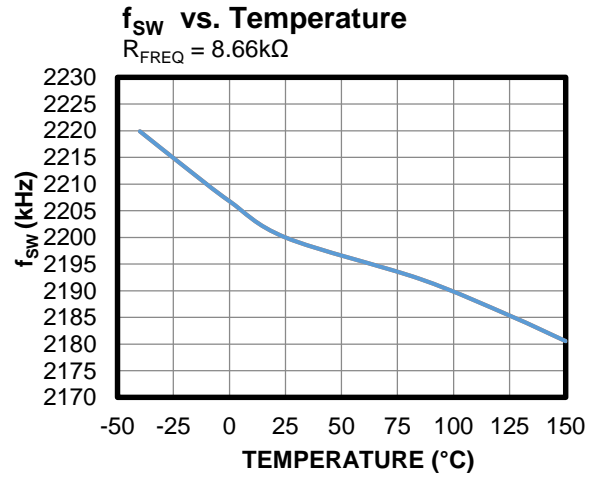
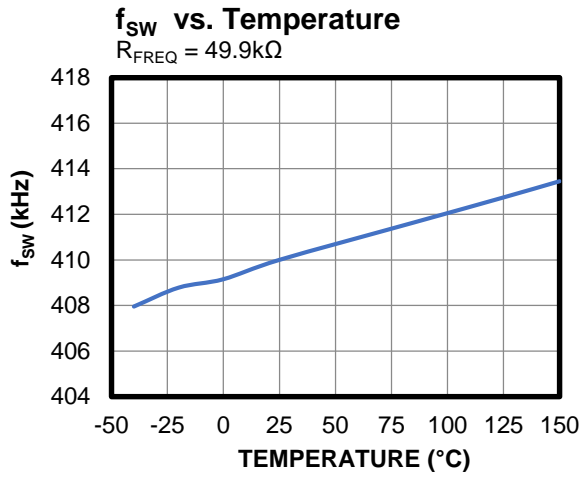

TYPICAL PERFORMANCE CHARACTERISTICS

$V_{IN} = 12V$, $V_{OUT} = 5V$, $L = 1\mu H$, $f_{SW} = 2.2MHz$, AAM mode, BIAS is connected to V_{OUT} , $T_A = 25^\circ C$, unless otherwise noted.

Input Current vs. Load Current

AAM mode, $V_{OUT} = 3.3V$, $f_{SW} = 2.2MHz$,
 $L = 1\mu H$ (DCR = 9.4m Ω)

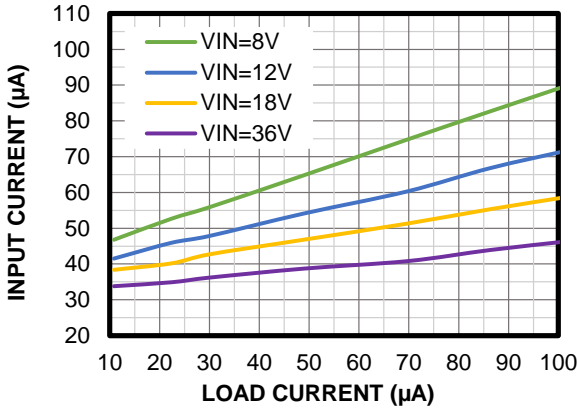

Efficiency vs. Load Current

AAM mode, $V_{OUT} = 3.3V$, $f_{SW} = 2.2MHz$,
 $L = 1\mu H$ (DCR = 9.4m Ω)

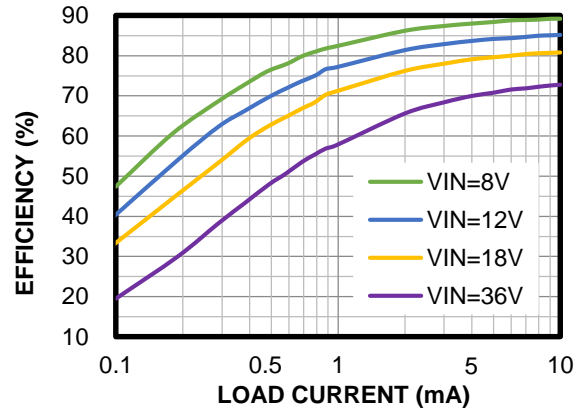

Efficiency vs. Load Current

AAM mode, $V_{OUT} = 3.3V$, $f_{SW} = 2.2MHz$,
 $L = 1\mu H$ (DCR = 9.4m Ω)

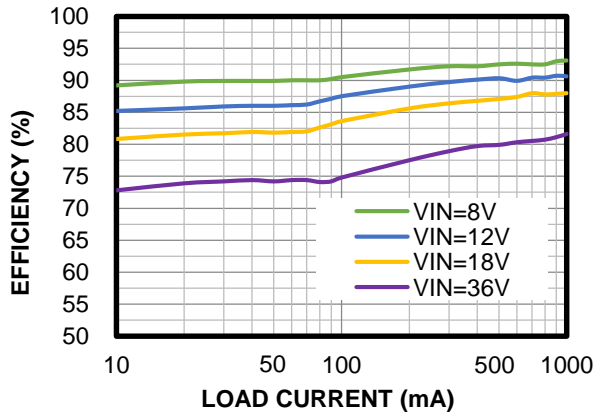

Efficiency vs. Load Current

AAM mode, $V_{OUT} = 3.3V$, $f_{SW} = 2.2MHz$,
 $L = 1\mu H$ (DCR = 9.4m Ω)

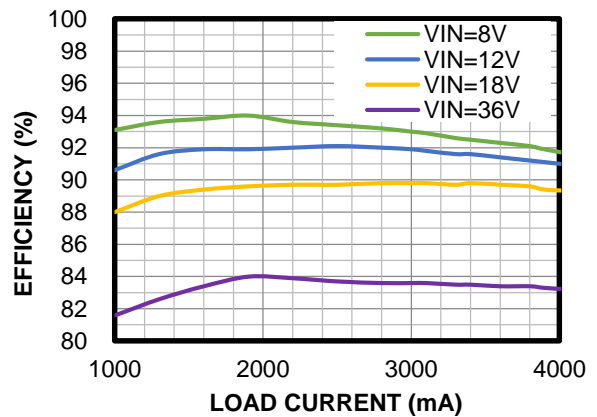

Efficiency vs. Load Current

FCCM, $V_{OUT} = 3.3V$, $f_{SW} = 2.2MHz$,
 $L = 1\mu H$ (DCR = 9.4m Ω)

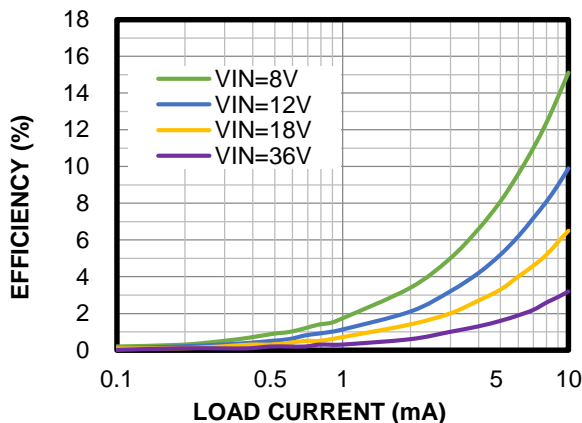

Efficiency vs. Load Current

FCCM, $V_{OUT} = 3.3V$, $f_{SW} = 2.2MHz$,
 $L = 1\mu H$ (DCR = 9.4m Ω)

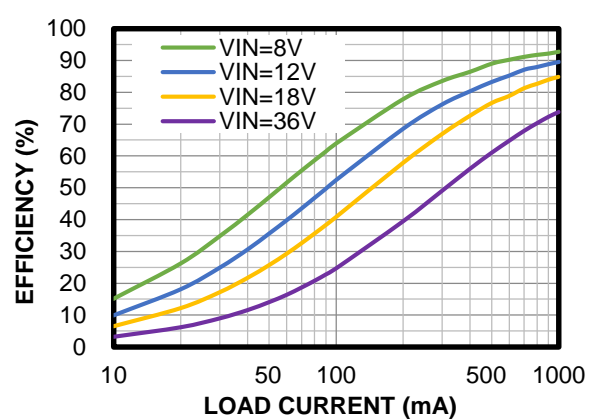

TYPICAL PERFORMANCE CHARACTERISTICS (continued)

V_{IN} = 12V, V_{OUT} = 5V, L = 1μH, f_{sw} = 2.2MHz, AAM mode, BIAS is connected to V_{OUT}, T_A = 25°C, unless otherwise noted.

Efficiency vs. Load Current

FCCM, V_{OUT} = 3.3V, f_{sw} = 2.2MHz,
L = 1μH (DCR = 9.4mΩ)

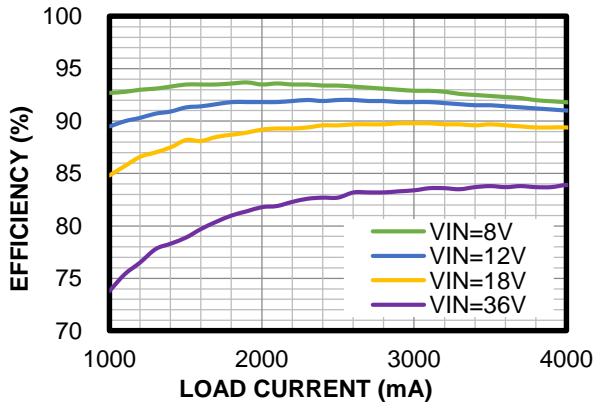

Input Current vs. Load Current

AAM mode, V_{OUT} = 5V, f_{sw} = 2.2MHz,
L = 1μH (DCR = 9.4mΩ)

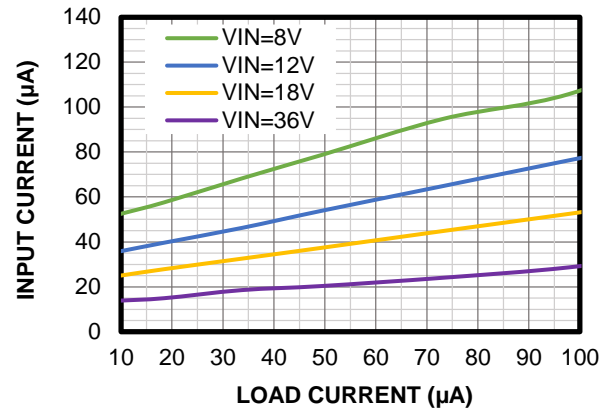

Efficiency vs. Load Current

AAM mode, V_{OUT} = 5V, f_{sw} = 2.2MHz,
L = 1μH (DCR = 9.4mΩ)

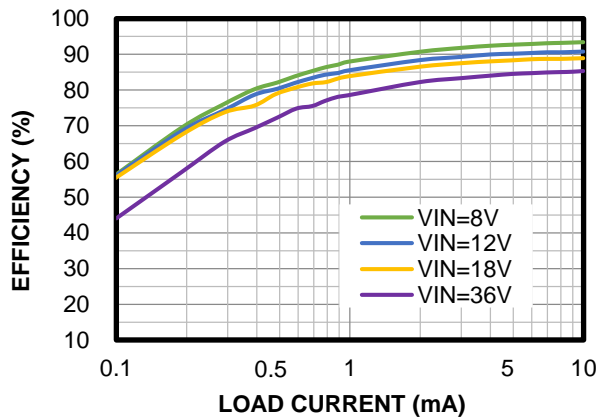

Efficiency vs. Load Current

AAM mode, V_{OUT} = 5V, f_{sw} = 2.2MHz,
L = 1μH (DCR = 9.4mΩ)

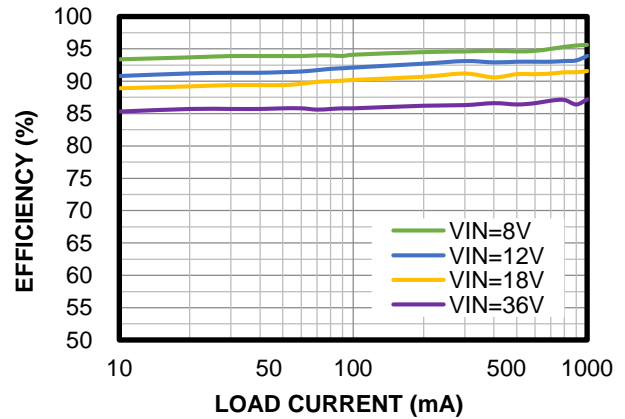

Efficiency vs. Load Current

AAM mode, V_{OUT} = 5V, f_{sw} = 2.2MHz,
L = 1μH (DCR = 9.4mΩ)

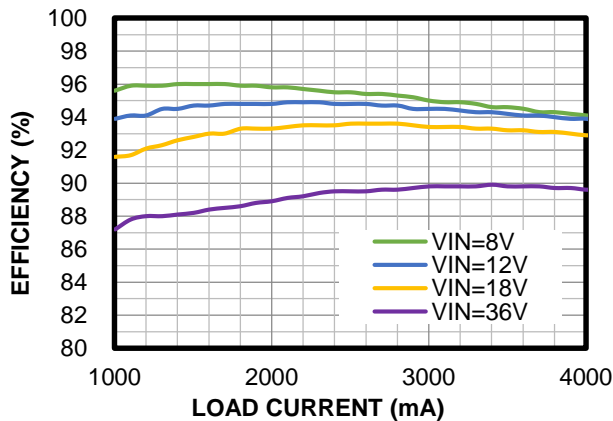

Efficiency vs. Load Current

FCCM, V_{OUT} = 5V, f_{sw} = 2.2MHz,
L = 1μH (DCR = 9.4mΩ)

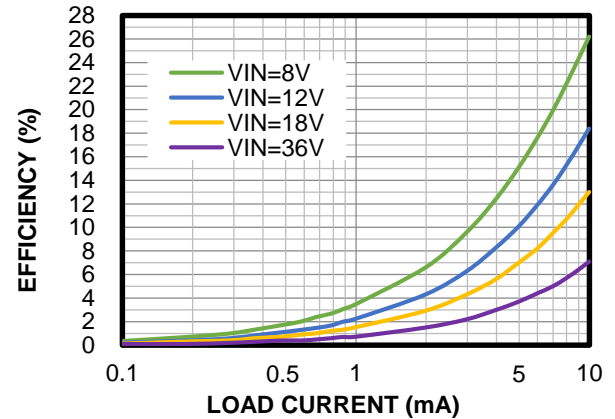

TYPICAL PERFORMANCE CHARACTERISTICS (continued)

V_{IN} = 12V, V_{OUT} = 5V, L = 1μH, f_{sw} = 2.2MHz, AAM mode, BIAS is connected to V_{OUT}, T_A = 25°C, unless otherwise noted.

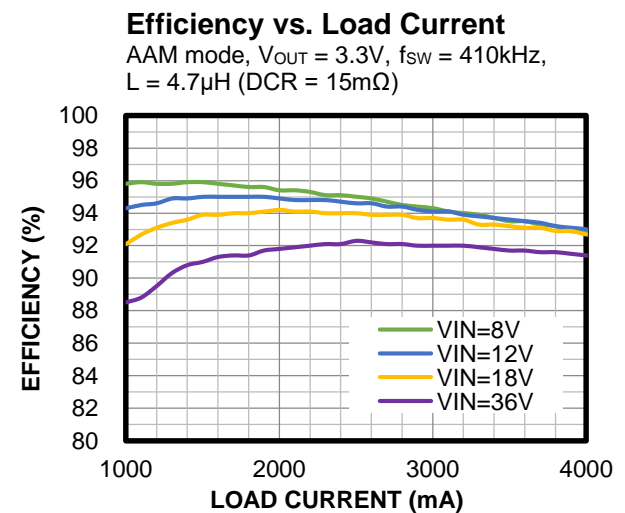
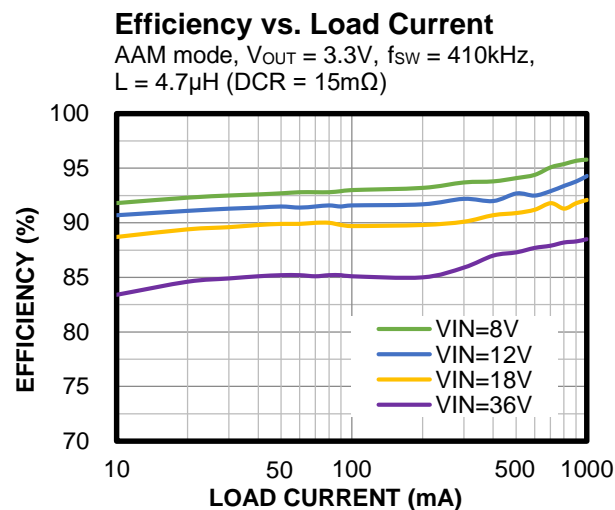
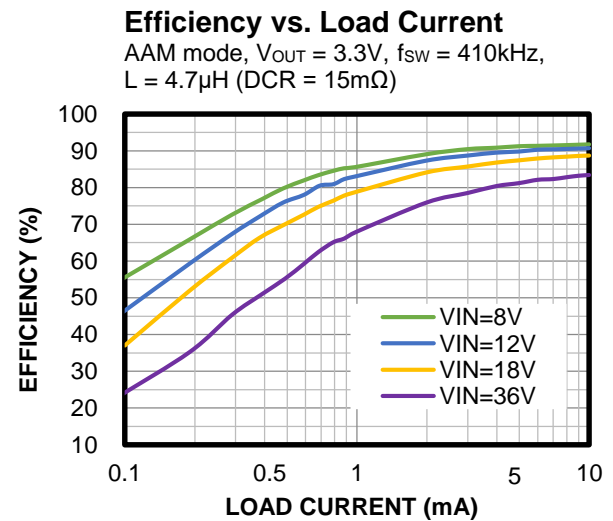
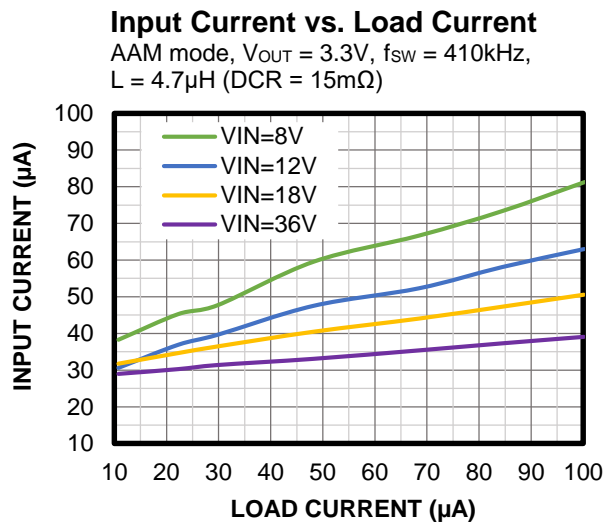
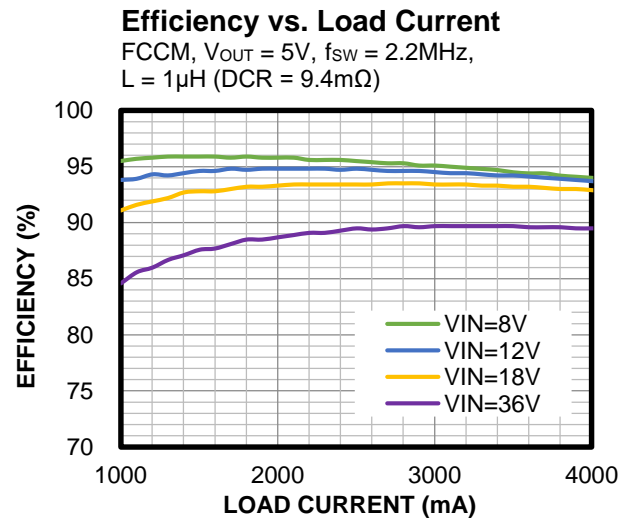
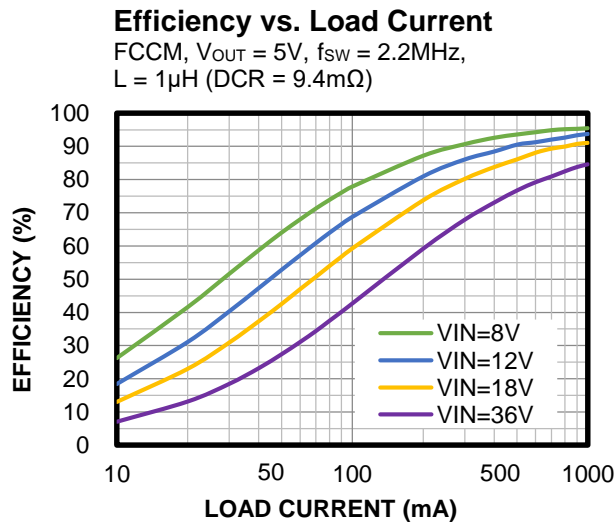

TYPICAL PERFORMANCE CHARACTERISTICS (continued)

V_{IN} = 12V, V_{OUT} = 5V, L = 1μH, f_{sw} = 2.2MHz, AAM mode, BIAS is connected to V_{OUT}, T_A = 25°C, unless otherwise noted.

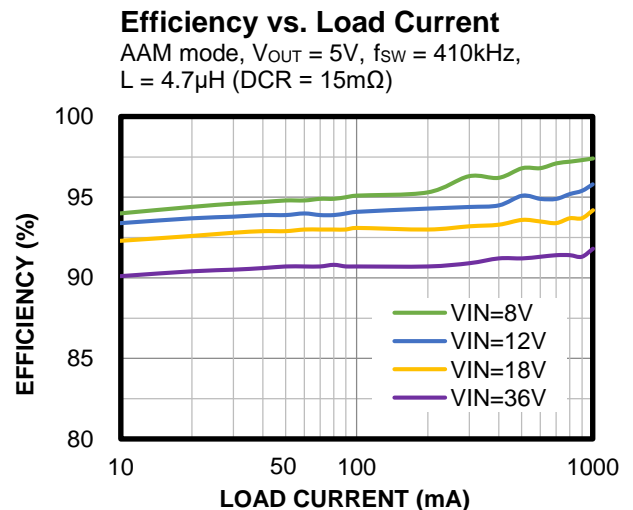
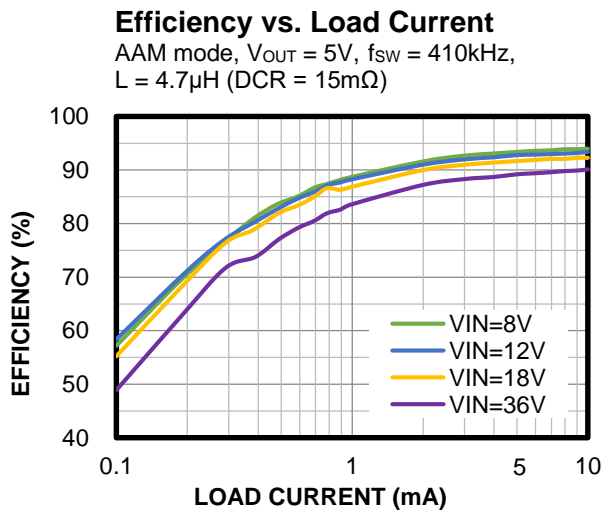
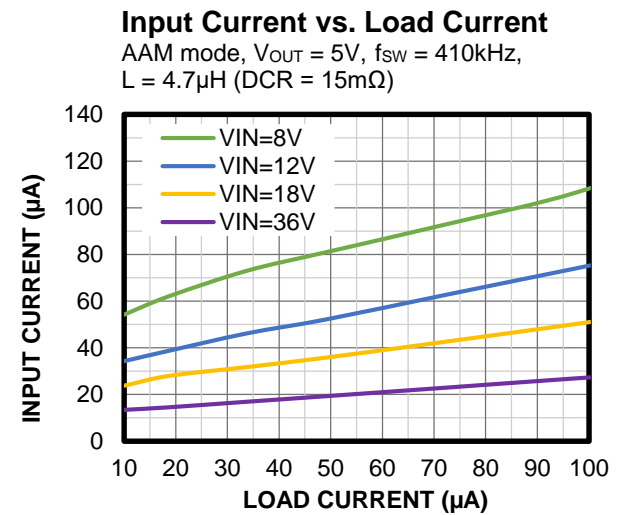
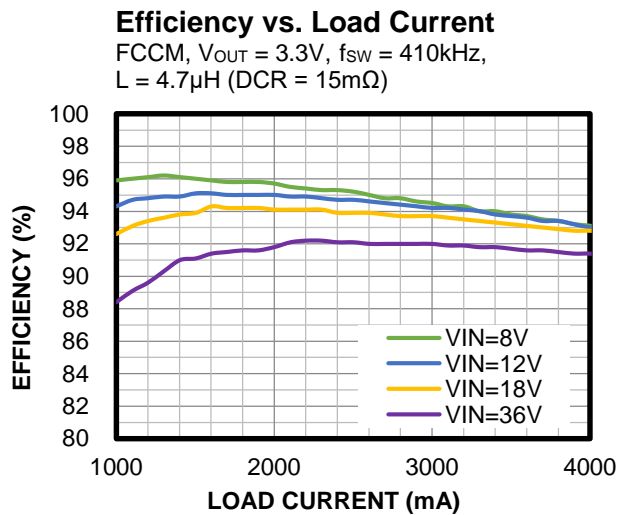
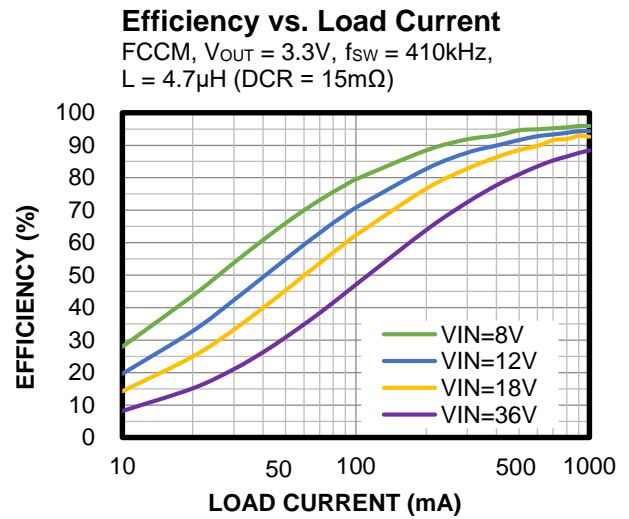
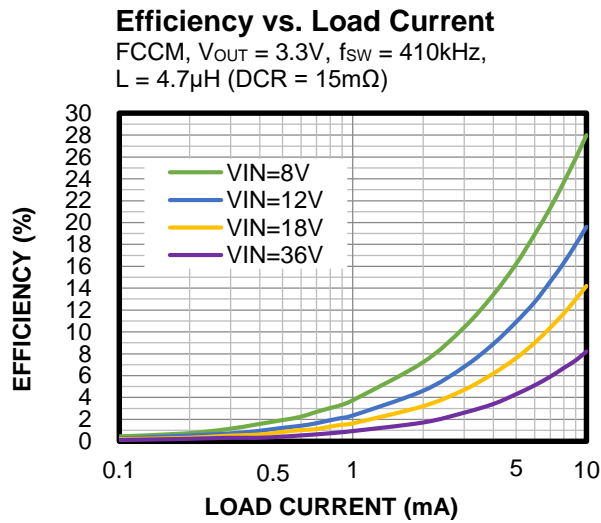

TYPICAL PERFORMANCE CHARACTERISTICS (continued)

V_{IN} = 12V, V_{OUT} = 5V, L = 1μH, f_{sw} = 2.2MHz, AAM mode, BIAS is connected to V_{OUT}, T_A = 25°C, unless otherwise noted.

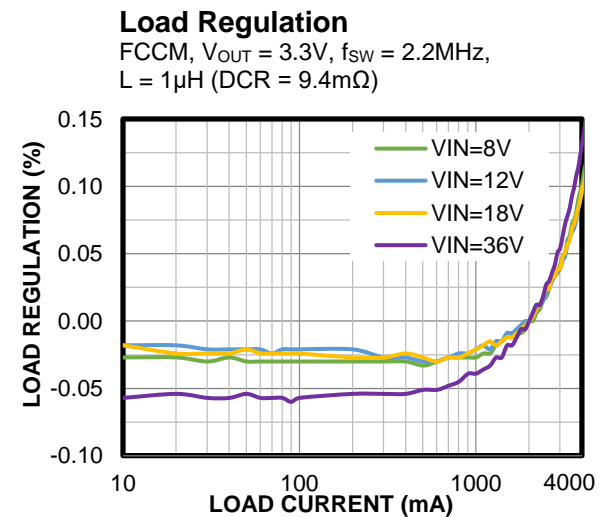
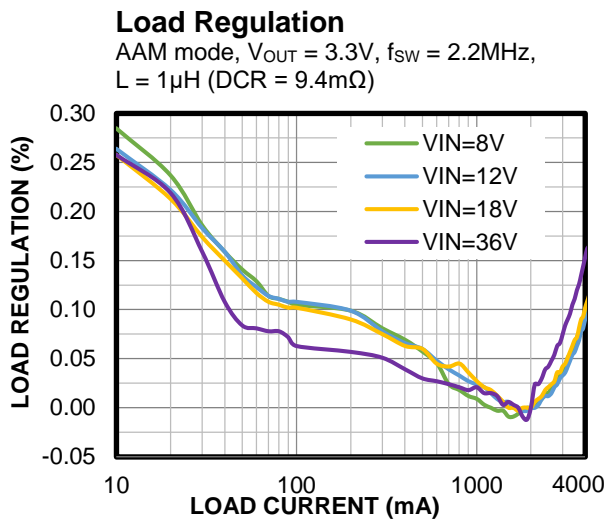
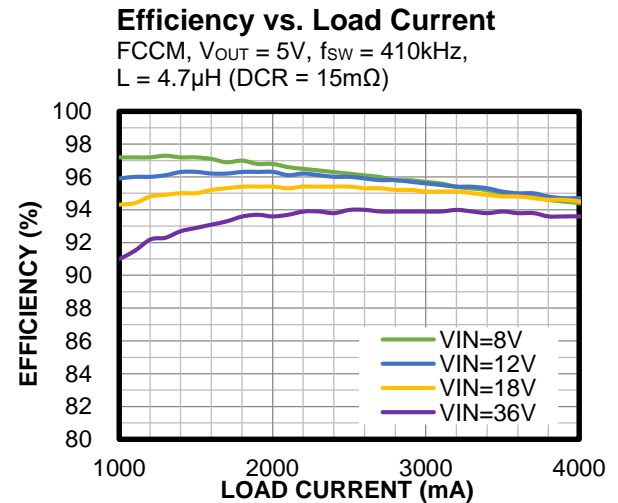
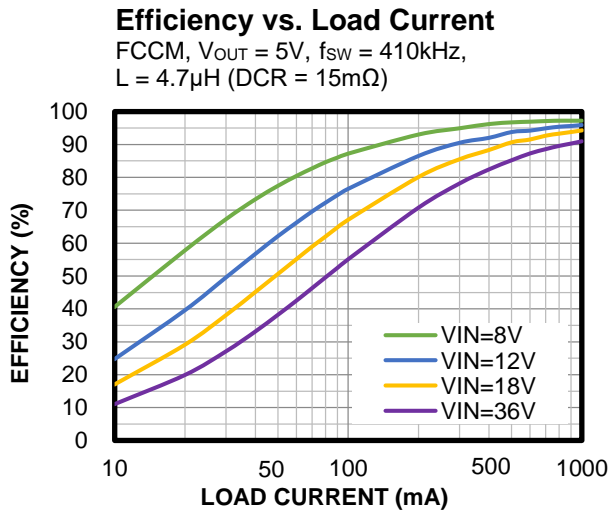
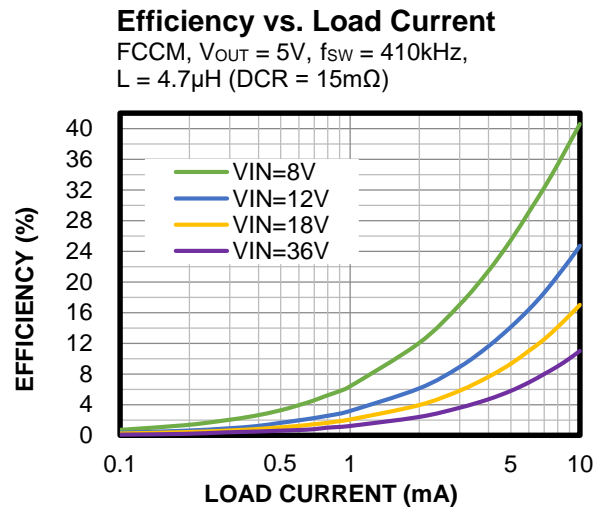
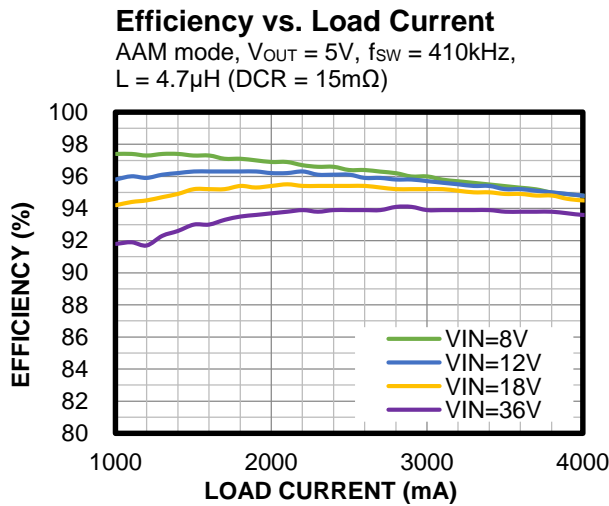

TYPICAL PERFORMANCE CHARACTERISTICS (continued)

V_{IN} = 12V, V_{OUT} = 5V, L = 1μH, f_{sw} = 2.2MHz, AAM mode, BIAS is connected to V_{OUT}, T_A = 25°C, unless otherwise noted.

Load Regulation

AAM mode, V_{OUT} = 5V, f_{sw} = 2.2MHz, L = 1μH (DCR = 9.4mΩ)

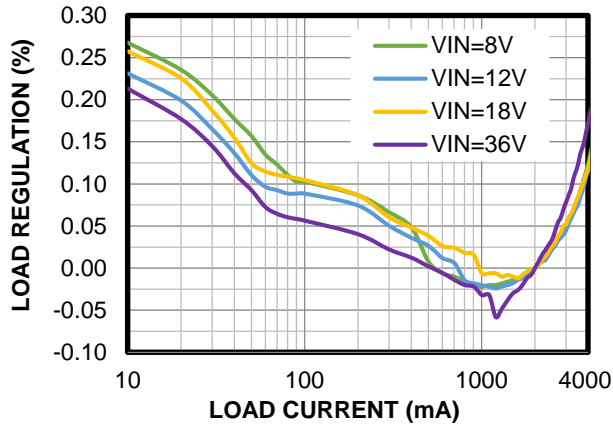

Load Regulation

FCCM, V_{OUT} = 5V, f_{sw} = 2.2MHz, L = 1μH (DCR = 9.4mΩ)

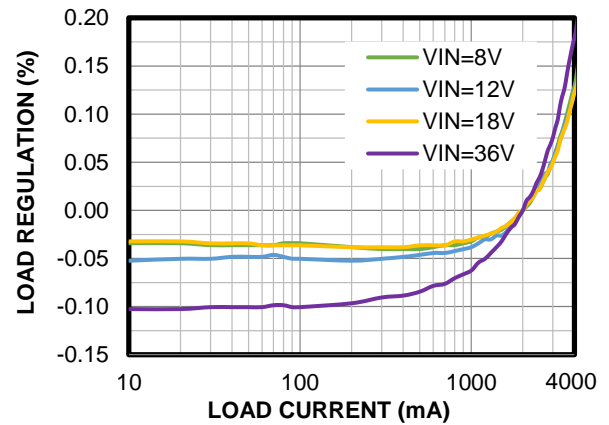

Load Regulation

AAM mode, V_{OUT} = 3.3V, f_{sw} = 410kHz, L = 4.7μH (DCR = 15mΩ)

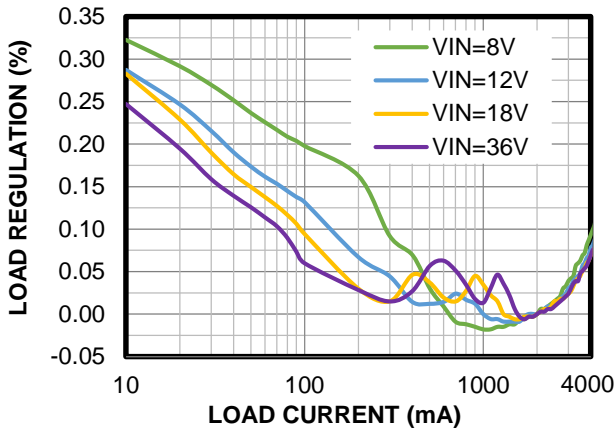

Load Regulation

FCCM, V_{OUT} = 3.3V, f_{sw} = 410kHz, L = 4.7μH (DCR = 15mΩ)

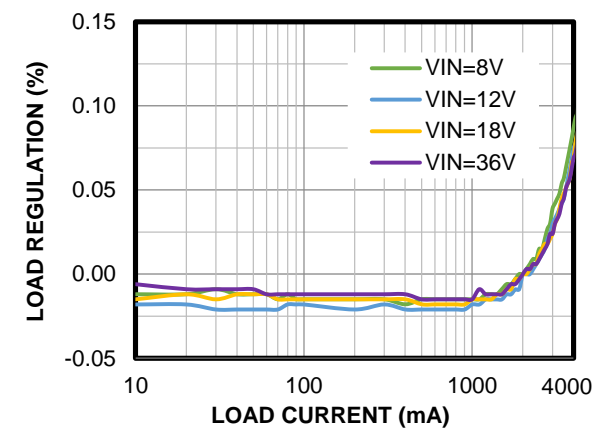

Load Regulation

AAM mode, V_{OUT} = 5V, f_{sw} = 410kHz, L = 4.7μH (DCR = 15mΩ)

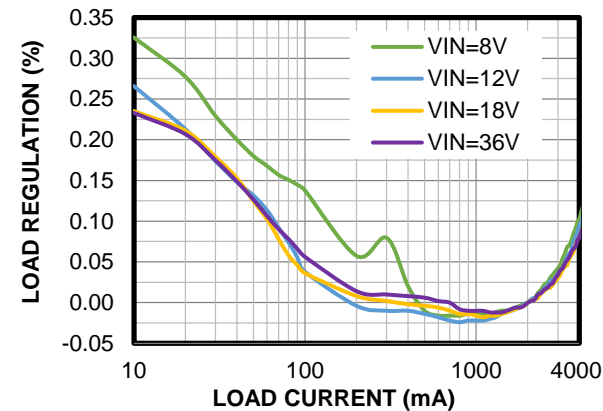

Load Regulation

FCCM, V_{OUT} = 5V, f_{sw} = 410kHz, L = 4.7μH (DCR = 15mΩ)

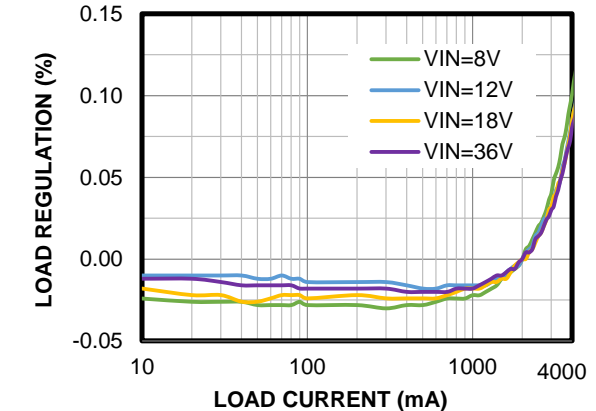

TYPICAL PERFORMANCE CHARACTERISTICS (continued)

V_{IN} = 12V, V_{OUT} = 5V, L = 1μH, f_{SW} = 2.2MHz, AAM mode, BIAS is connected to V_{OUT}, T_A = 25°C, unless otherwise noted.

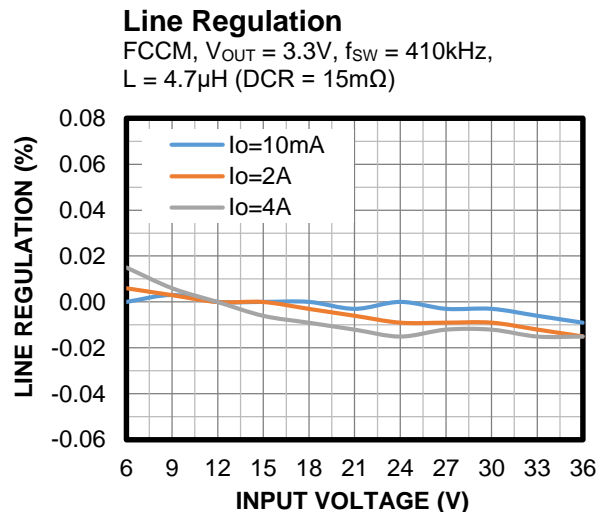
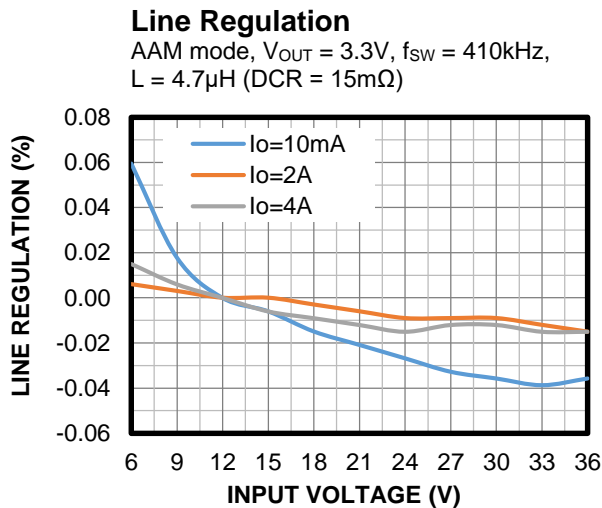
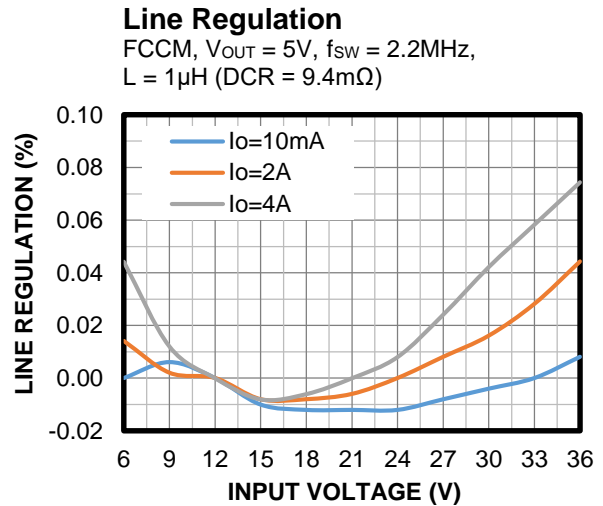
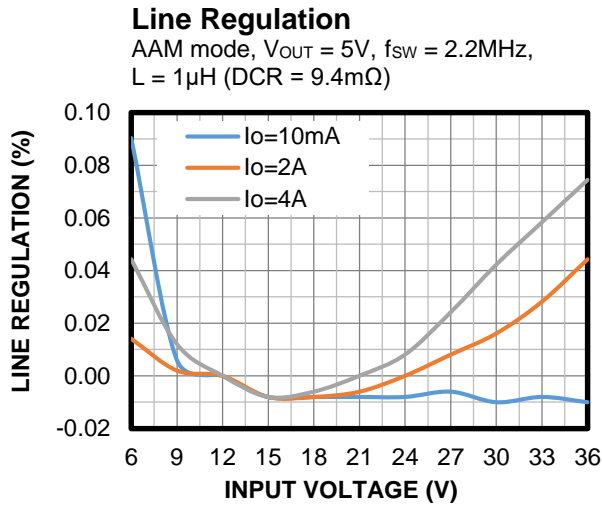
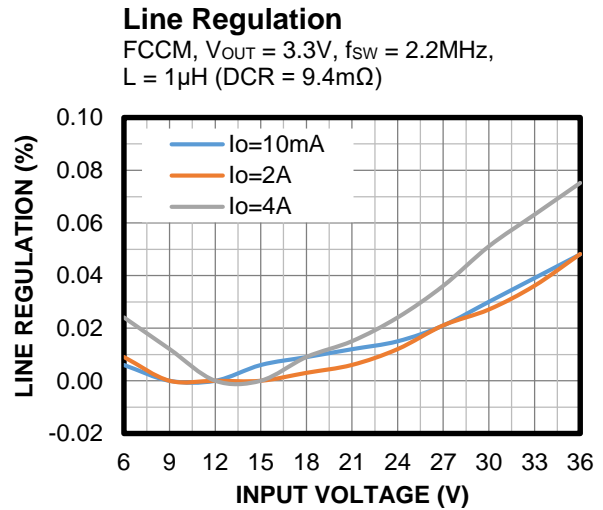
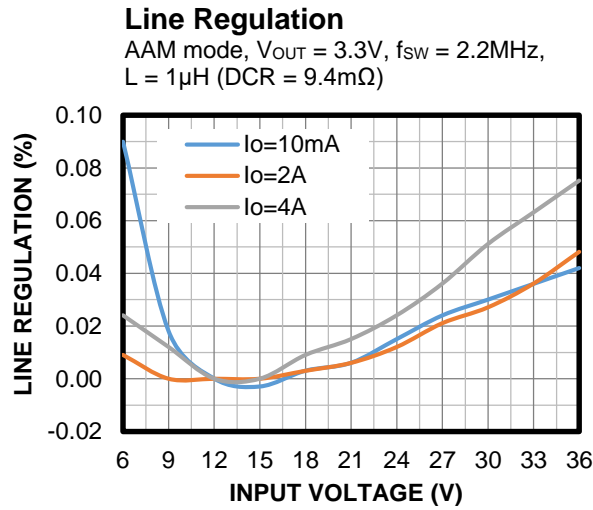

TYPICAL PERFORMANCE CHARACTERISTICS (continued)

V_{IN} = 12V, V_{OUT} = 5V, L = 1μH, f_{sw} = 2.2MHz, AAM mode, BIAS is connected to V_{OUT}, T_A = 25°C, unless otherwise noted.

Line Regulation

AAM mode, V_{OUT} = 5V, f_{sw} = 410kHz,
L = 4.7μH (DCR = 15mΩ)

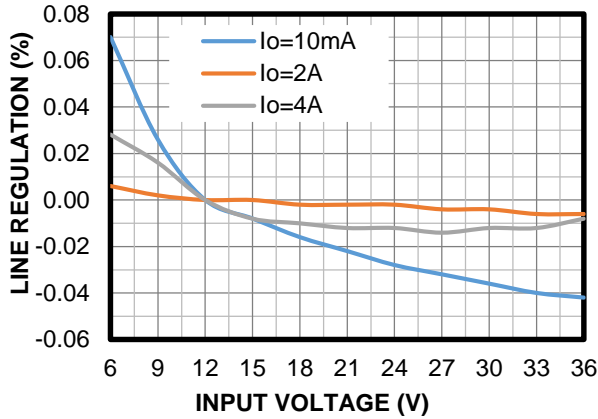

Line Regulation

FCCM, V_{OUT} = 5V, f_{sw} = 410kHz,
L = 4.7μH (DCR = 15mΩ)

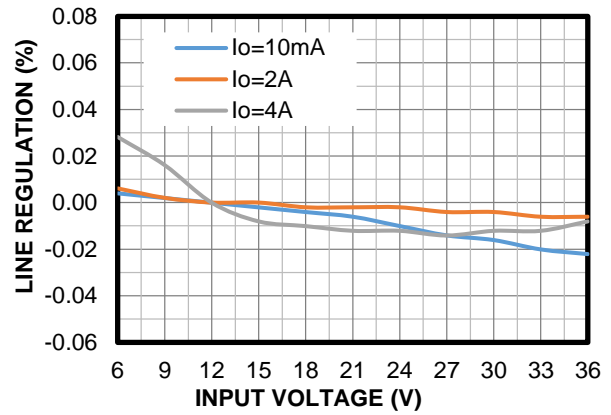

Case Temperature Rise

V_{OUT} = 3.3V, f_{sw} = 2.2MHz,
L = 1μH (DCR = 9.4mΩ)

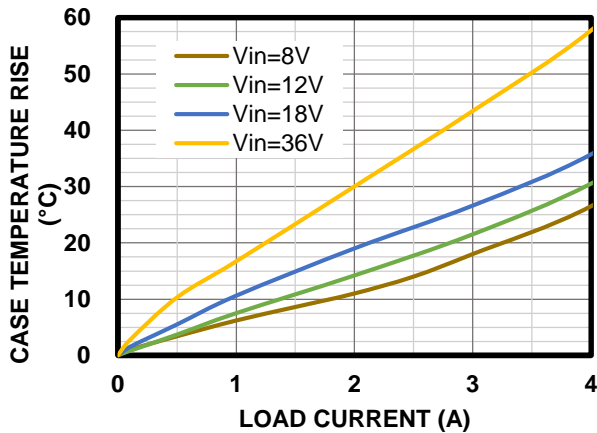

Case Temperature Rise

V_{OUT} = 5V, f_{sw} = 2.2MHz,
L = 1μH (DCR = 9.4mΩ)

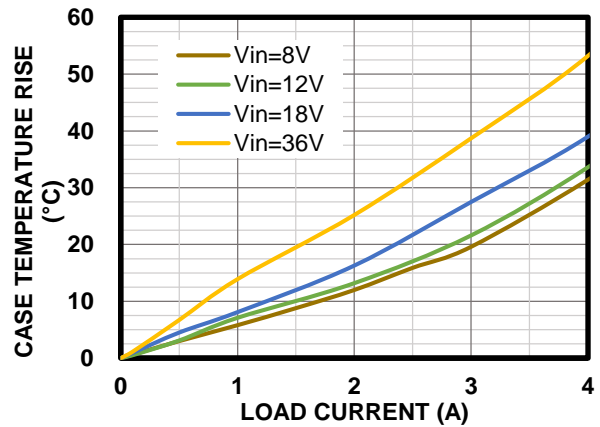

Case Temperature Rise

V_{OUT} = 3.3V, f_{sw} = 410kHz,
L = 4.7μH (DCR = 15mΩ)

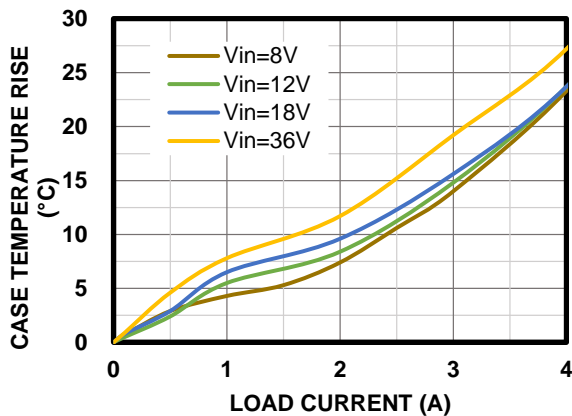

Case Temperature Rise

V_{OUT} = 5V, f_{sw} = 410kHz,
L = 4.7μH (DCR = 15mΩ)

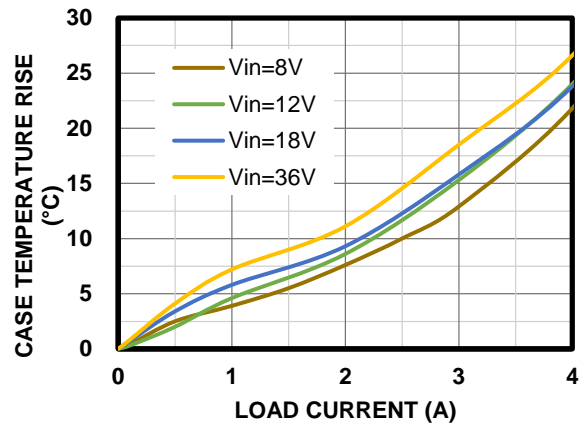

TYPICAL PERFORMANCE CHARACTERISTICS *(continued)*

$V_{IN} = 12V$, $V_{OUT} = 5V$, $L = 1\mu H$, $f_{SW} = 2.2MHz$, AAM mode, BIAS is connected to V_{OUT} , $T_A = 25^\circ C$, unless otherwise noted.

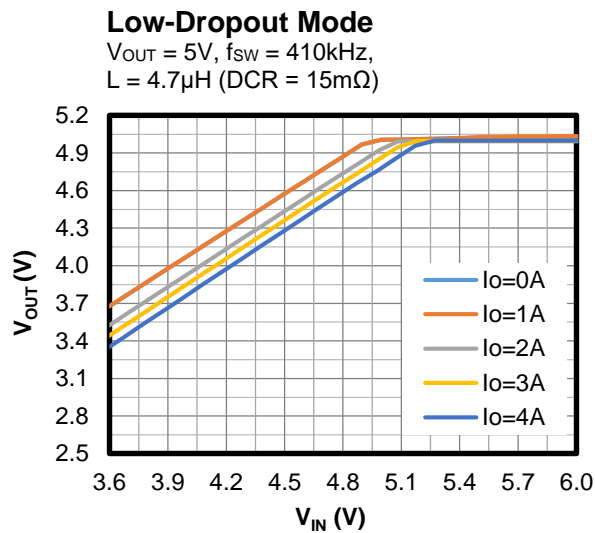
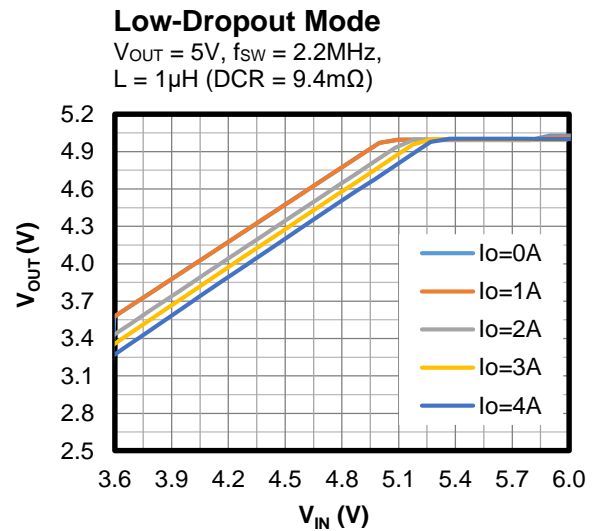
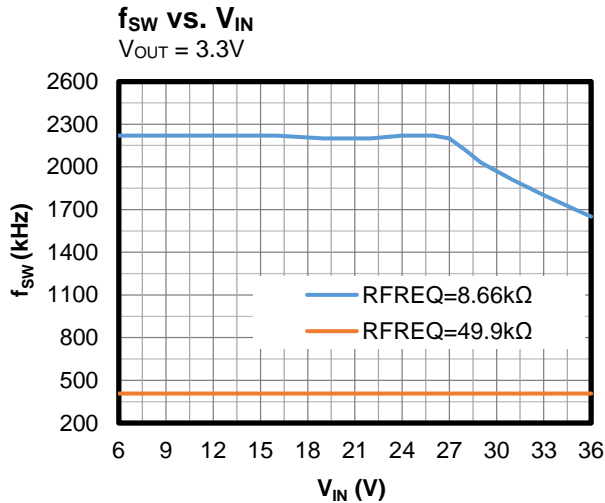

TYPICAL PERFORMANCE CHARACTERISTICS (continued)

$V_{IN} = 12V$, $V_{OUT} = 5V$, $I_{OUT} = 4A$, $L = 1\mu H$ ⁽¹¹⁾, $f_{SW} = 2.2MHz$, $T_A = 25^\circ C$, unless otherwise noted. ⁽¹²⁾

CISPR25 Class 5 Peak Conducted Emissions
150kHz to 108MHz

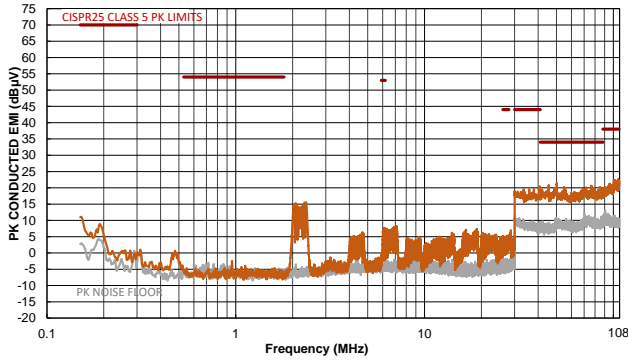

CISPR25 Class 5 Average Conducted Emissions
150kHz to 108MHz

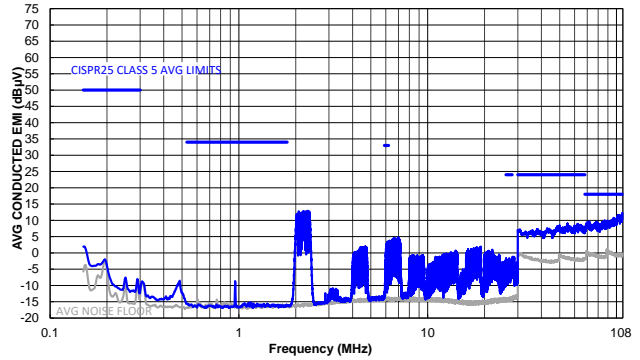

CISPR25 Class 5 Peak Radiated Emissions
150kHz to 30MHz

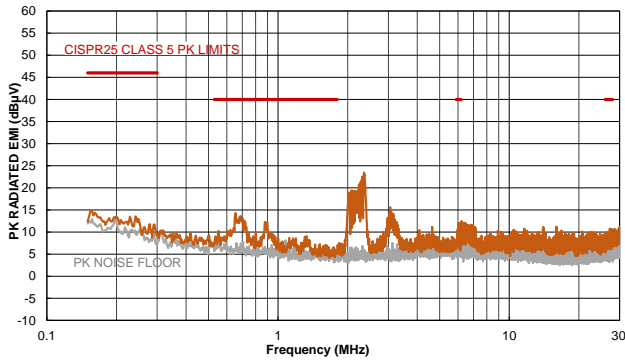

CISPR25 Class 5 Average Radiated Emissions
150kHz to 30MHz

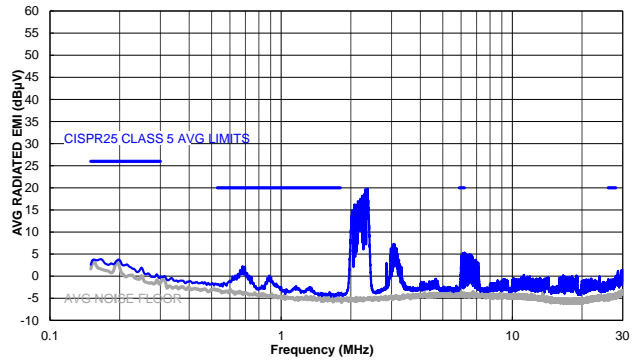

CISPR25 Class 5 Peak Radiated Emissions
Horizontal, 30MHz to 1GHz

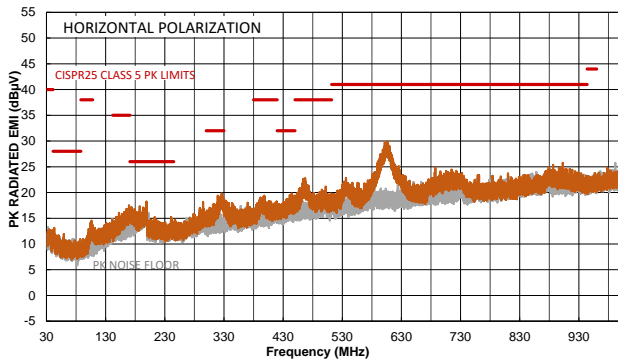

CISPR25 Class 5 Average Radiated Emissions
Horizontal, 30MHz to 1GHz

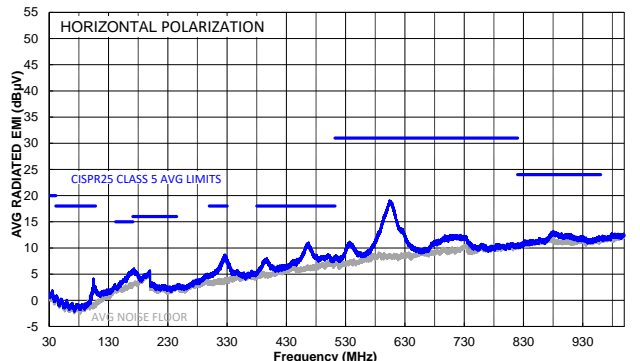

TYPICAL PERFORMANCE CHARACTERISTICS *(continued)*

V_{IN} = 12V, V_{OUT} = 5V, I_{OUT} = 4A, L = 1μH ⁽¹¹⁾, f_{SW} = 2.2MHz, T_A = 25°C, unless otherwise noted. ⁽¹²⁾

CISPR25 Class 5 Peak Radiated Emissions

Vertical, 30MHz to 1GHz

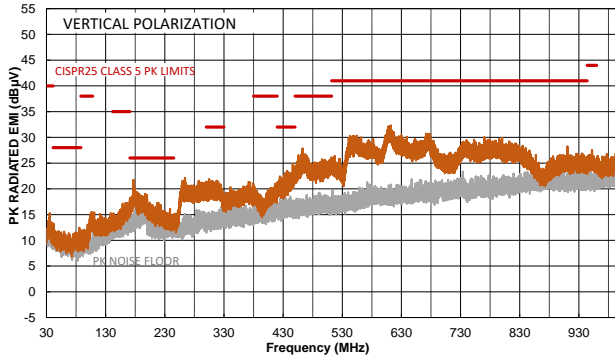

CISPR25 Class 5 Average Radiated Emissions

Vertical, 30MHz to 1GHz

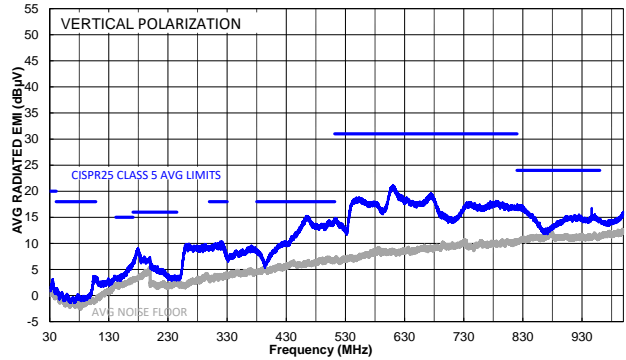

Notes:

11) Inductor part number: XEL4020-102MEB; DCR = 14.6mΩ.

12) The EMC test results are based on the application circuit with EMI filters (see Figure 17 on page 44).

TYPICAL PERFORMANCE CHARACTERISTICS (continued)

$V_{IN} = 12V$, $V_{OUT} = 5V$, $I_{OUT} = 4A$, $L = 4.7\mu H$ ⁽¹³⁾, $f_{SW} = 410kHz$, $T_A = 25^\circ C$, unless otherwise noted. ⁽¹⁴⁾

CISPR25 Class 5 Peak Conducted Emissions

150kHz to 108MHz

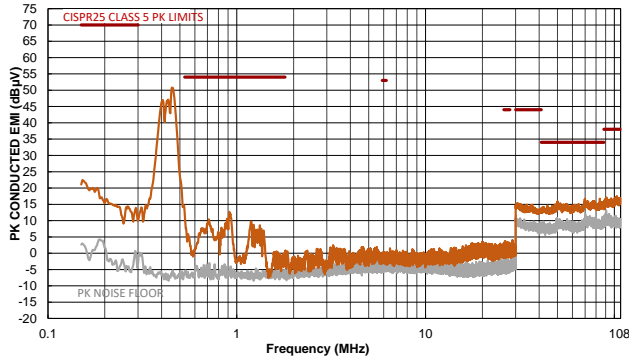

CISPR25 Class 5 Average Conducted Emissions

150kHz to 108MHz

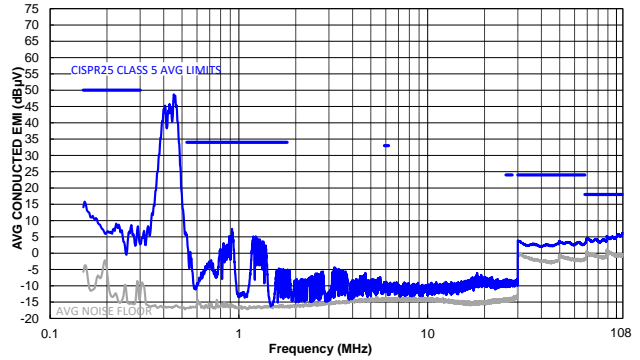

CISPR25 Class 5 Peak Radiated Emissions

150kHz to 30MHz

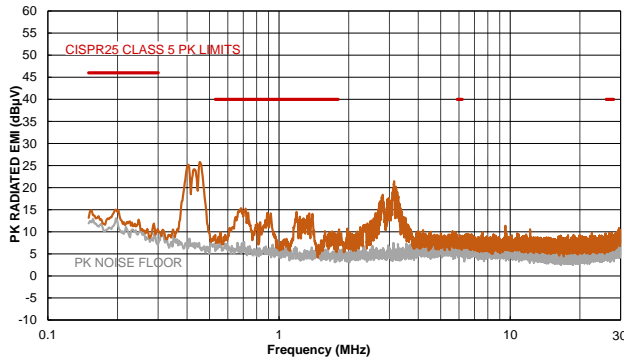

CISPR25 Class 5 Average Radiated Emissions

150kHz to 30MHz

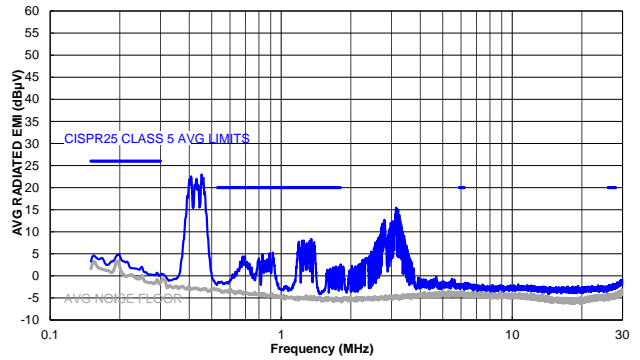

CISPR25 Class 5 Peak Radiated Emissions

Horizontal, 30MHz to 1GHz

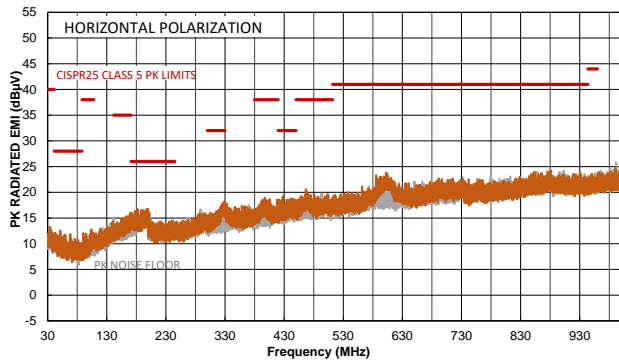

CISPR25 Class 5 Average Radiated Emissions

Horizontal, 30MHz to 1GHz

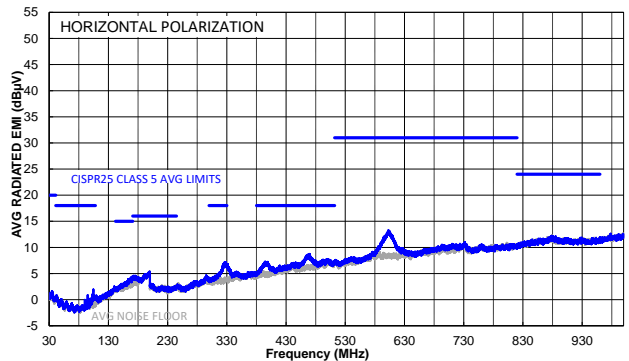

TYPICAL PERFORMANCE CHARACTERISTICS (continued)

V_{IN} = 12V, V_{OUT} = 5V, I_{OUT} = 4A, L = 4.7μH⁽¹³⁾, f_{SW} = 410kHz, T_A = 25°C, unless otherwise noted.⁽¹⁴⁾

CISPR25 Class 5 Peak Radiated Emissions

Vertical, 30MHz to 1GHz

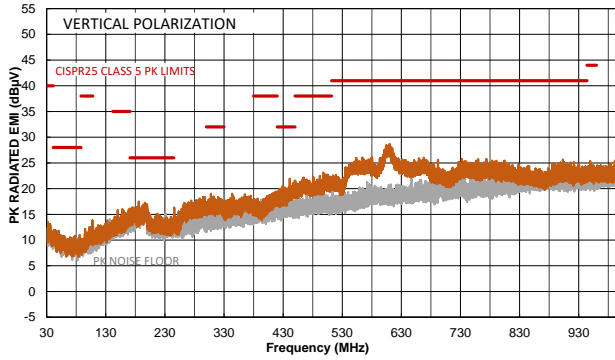

CISPR25 Class 5 Average Radiated Emissions

Vertical, 30MHz to 1GHz

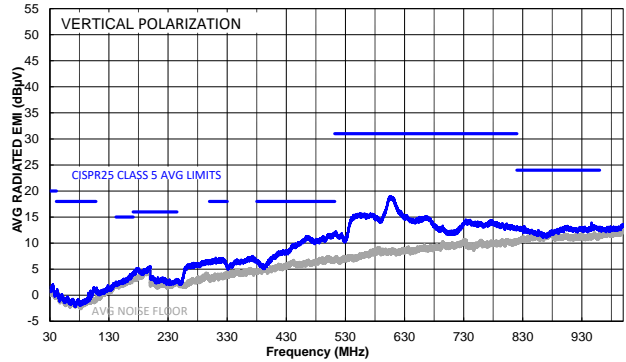

Notes:

13) Inductor part number: XEL6060-472MEB/C; DCR = 15.02mΩ.

14) The EMC test results are based on the application circuit with EMI filters (see Figure 18 on page 45).

TYPICAL PERFORMANCE CHARACTERISTICS (continued)
 $V_{IN} = 12V$, $V_{OUT} = 5V$, $L = 1\mu H$, $f_{SW} = 2.2MHz$, AAM mode, $T_A = 25^\circ C$, unless otherwise noted.

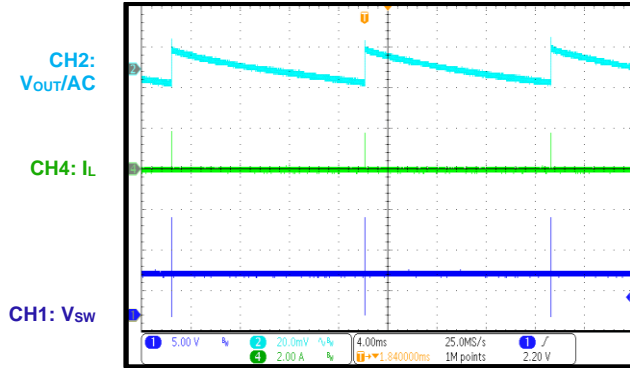
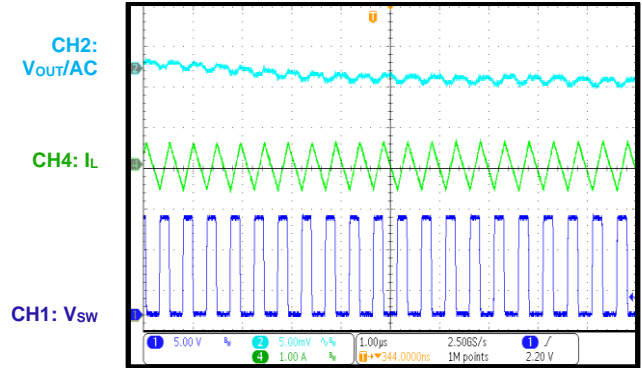
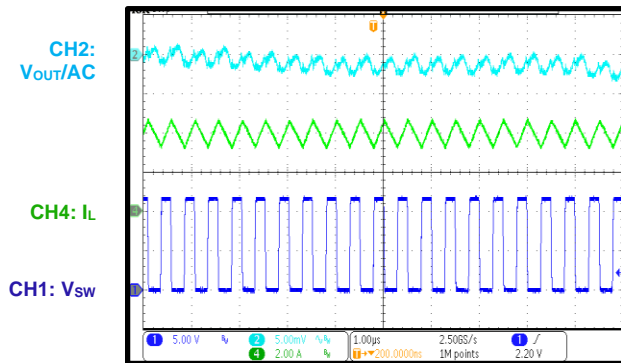
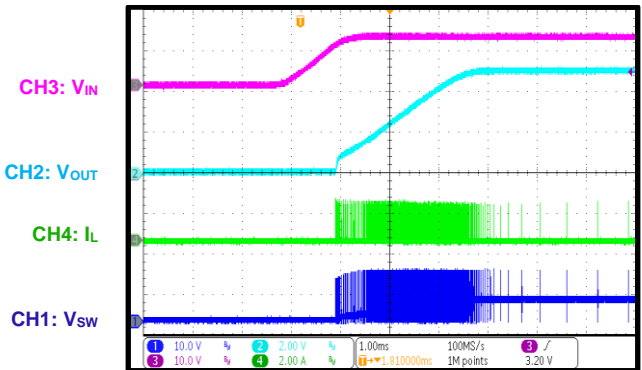
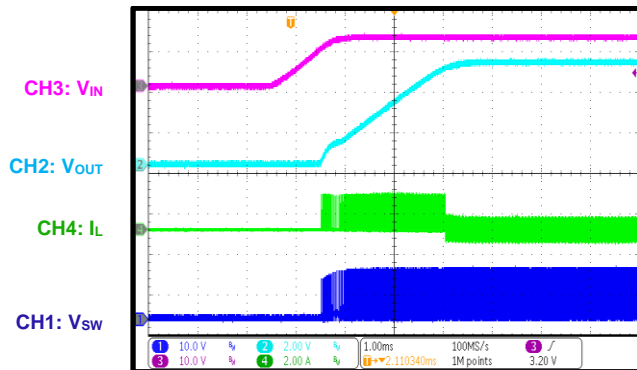
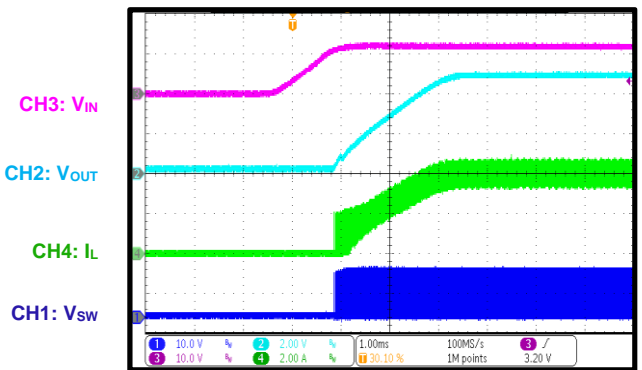
Steady State
 $I_{OUT} = 0A$, AAM mode

Steady State
 $I_{OUT} = 0A$, FCCM

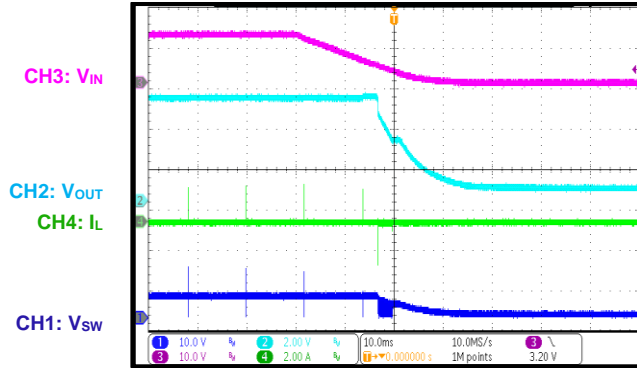
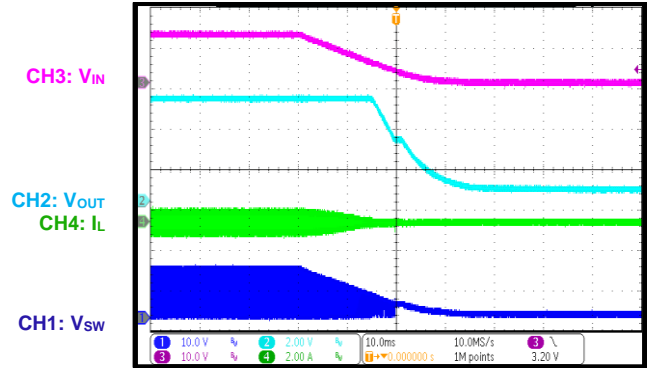
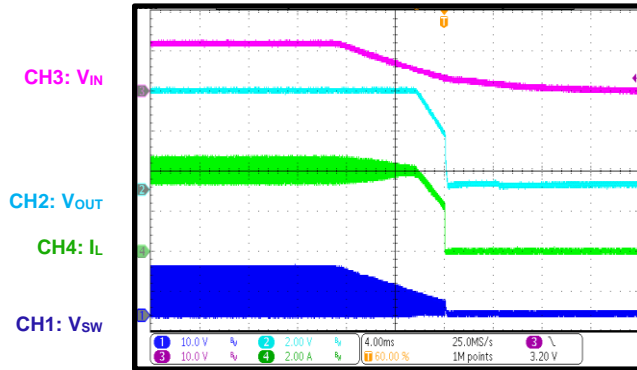
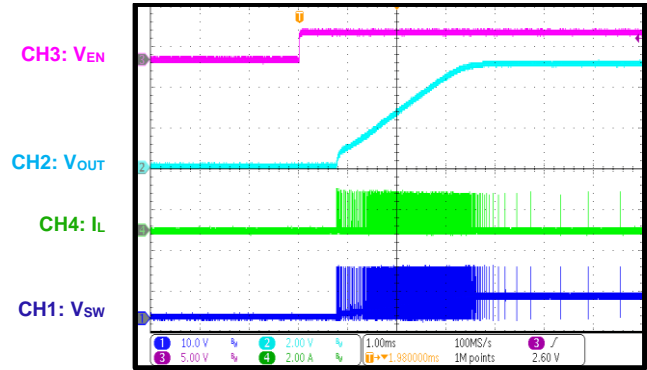
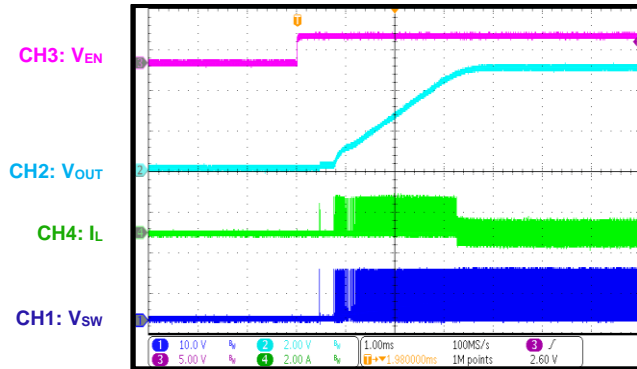
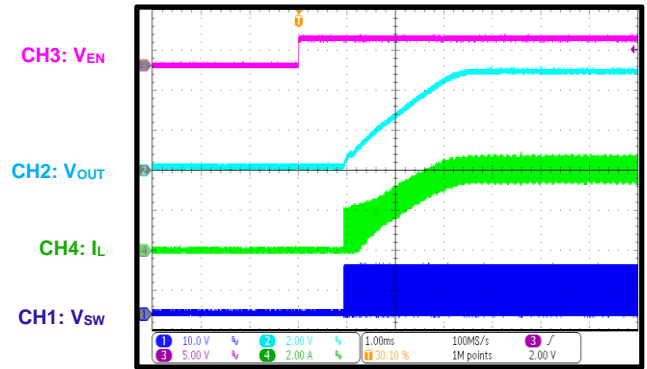
Steady State
 $V_{IN} = 12V$, $I_{OUT} = 4A$

Start-Up through VIN
 $I_{OUT} = 0A$, AAM mode

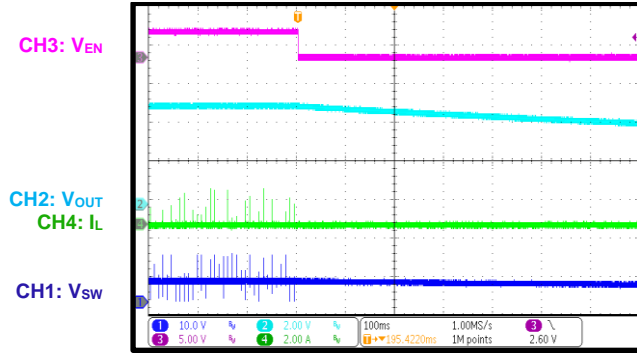
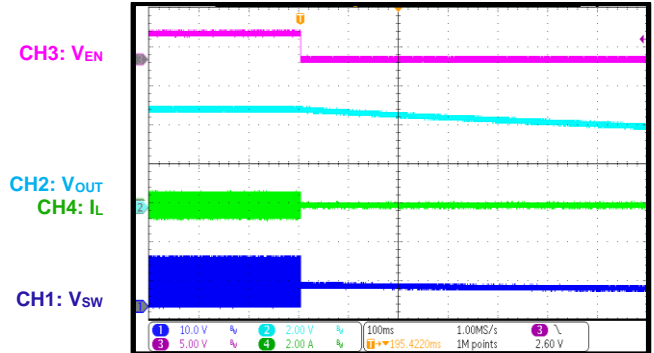
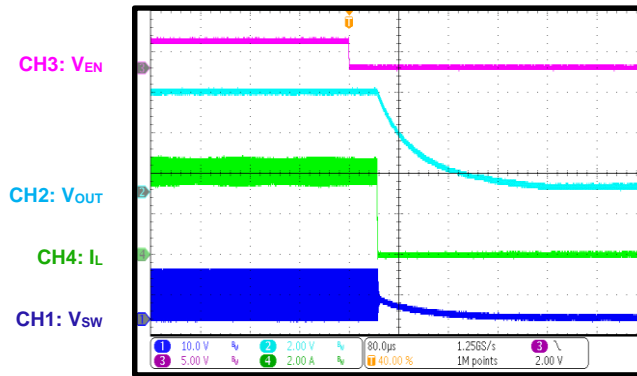
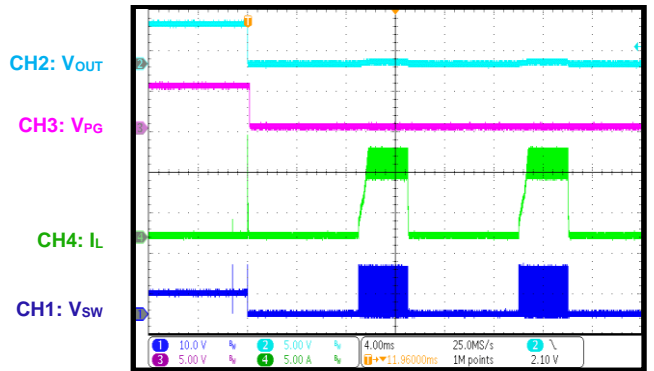
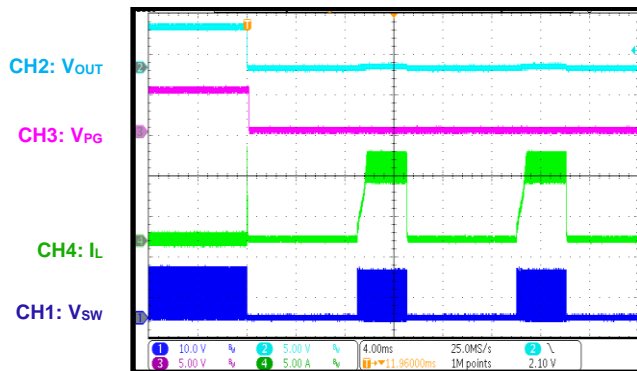
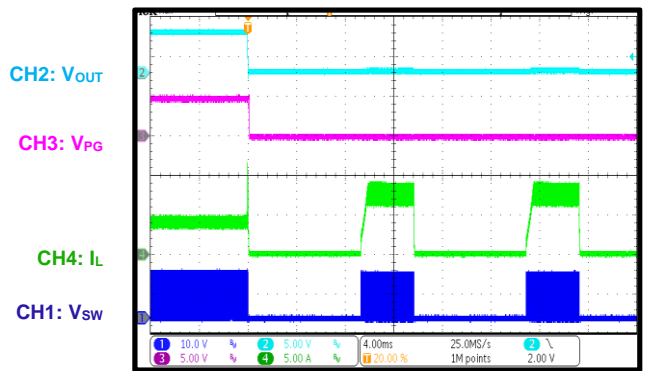
Start-Up through VIN
 $I_{OUT} = 0A$, FCCM

Start-Up through VIN
 $V_{IN} = 12A$, $I_{OUT} = 4A$

TYPICAL PERFORMANCE CHARACTERISTICS (continued)
 $V_{IN} = 12V$, $V_{OUT} = 5V$, $L = 1\mu H$, $f_{SW} = 2.2MHz$, AAM mode, $T_A = 25^\circ C$, unless otherwise noted.

Shutdown through VIN
 $I_{OUT} = 0A$, AAM mode

Shutdown through VIN
 $I_{OUT} = 0A$, FCCM

Shutdown through VIN
 $V_{IN} = 12A$, $I_{OUT} = 4A$

Start-Up through EN
 $I_{OUT} = 0A$, AAM mode

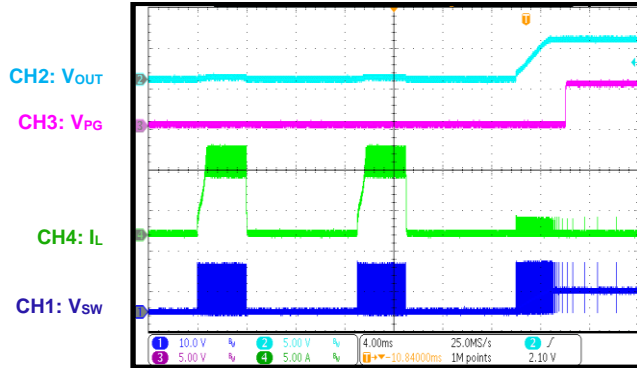
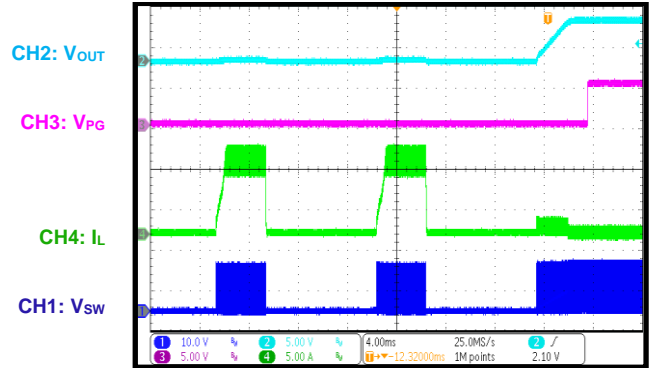
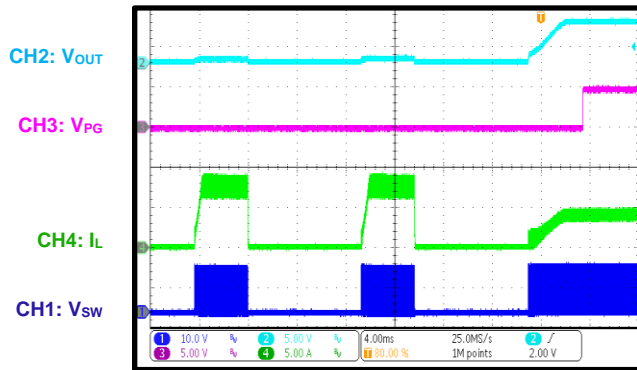
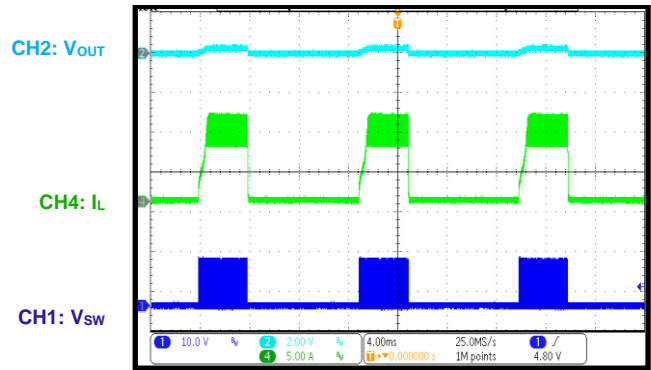
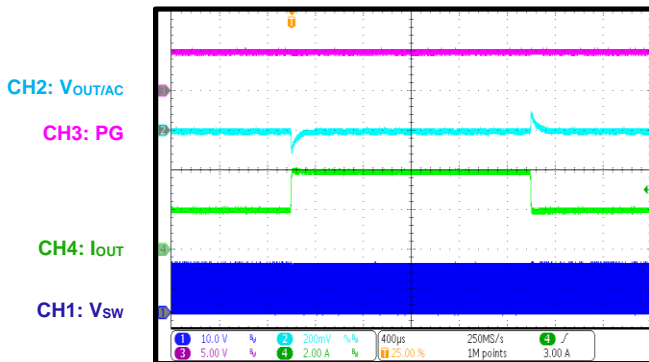
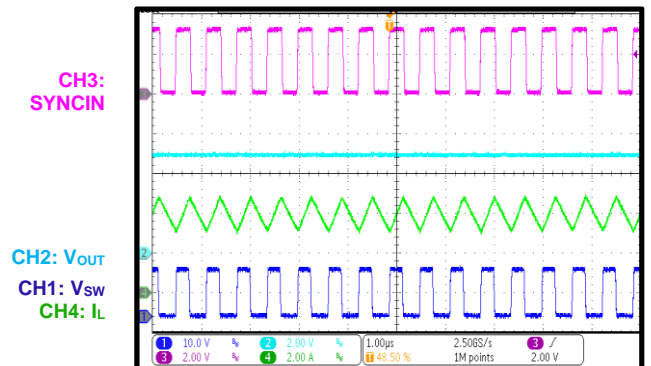
Start-Up through EN
 $I_{OUT} = 0A$, FCCM

Start-Up through EN
 $V_{IN} = 12V$, $I_{OUT} = 4A$

TYPICAL PERFORMANCE CHARACTERISTICS (continued)
 $V_{IN} = 12V$, $V_{OUT} = 5V$, $L = 1\mu H$, $f_{SW} = 2.2MHz$, AAM mode, $T_A = 25^\circ C$, unless otherwise noted.

Shutdown through EN
 $I_{OUT} = 0A$, AAM mode

Shutdown through EN
 $I_{OUT} = 0A$, FCCM

Shutdown through EN
 $I_{OUT} = 4A$

SCP Entry
 $I_{OUT} = 0A$, AAM mode

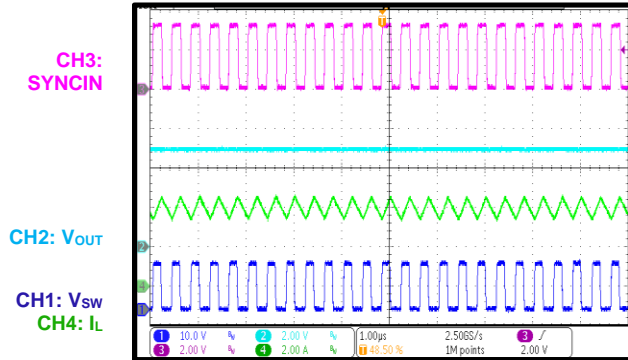
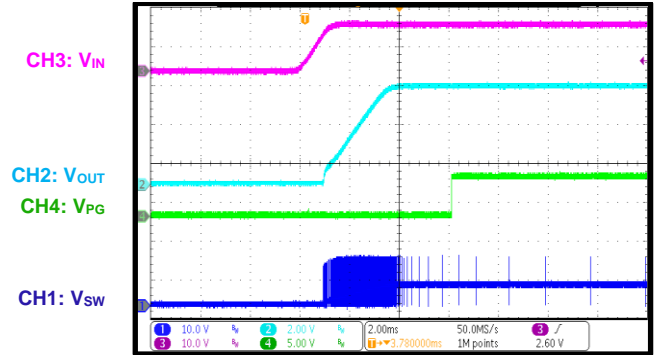
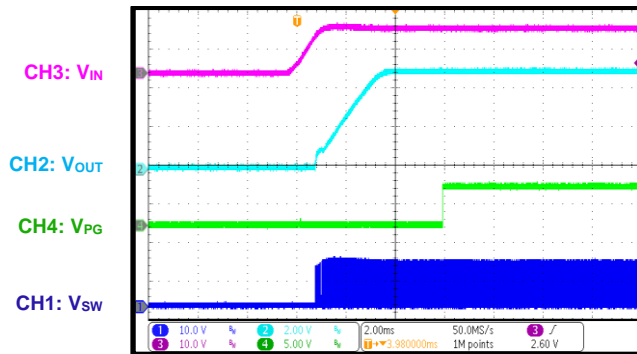
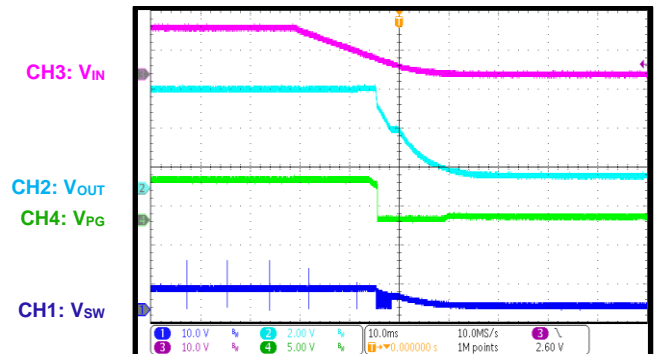
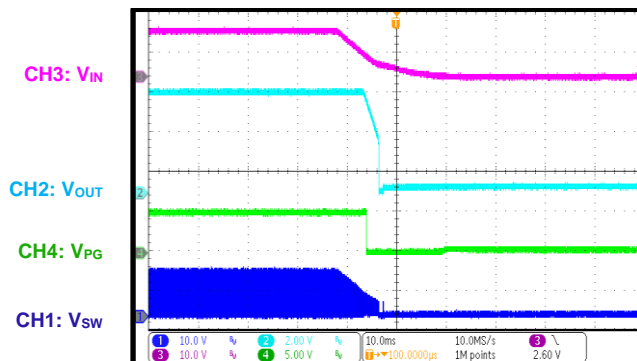
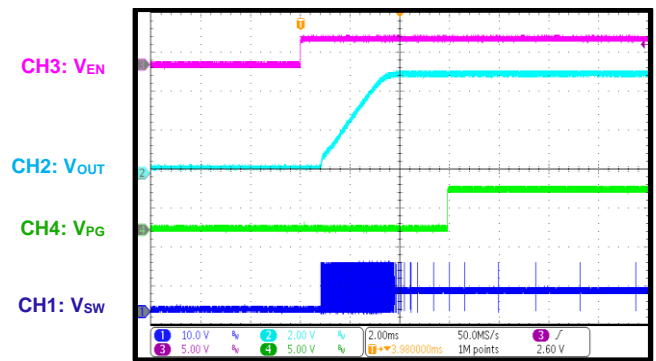
SCP Entry
 $I_{OUT} = 0A$, FCCM

SCP Entry
 $I_{OUT} = 4A$

TYPICAL PERFORMANCE CHARACTERISTICS (continued)
 $V_{IN} = 12V$, $V_{OUT} = 5V$, $L = 1\mu H$, $f_{SW} = 2.2MHz$, AAM mode, $T_A = 25^{\circ}C$, unless otherwise noted.

SCP Recovery
 $I_{OUT} = 0A$, AAM mode

SCP Recovery
 $I_{OUT} = 0A$, FCCM

SCP Recovery
 $I_{OUT} = 4A$

SCP Steady State

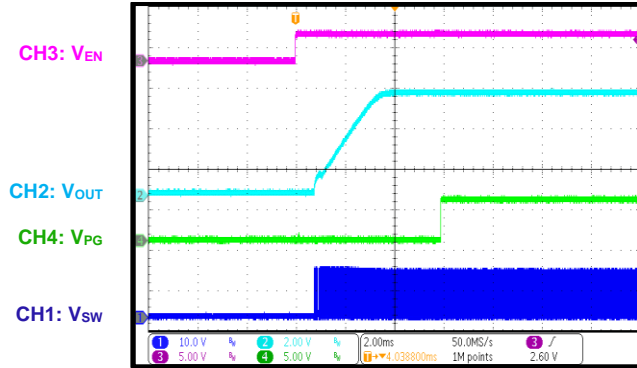
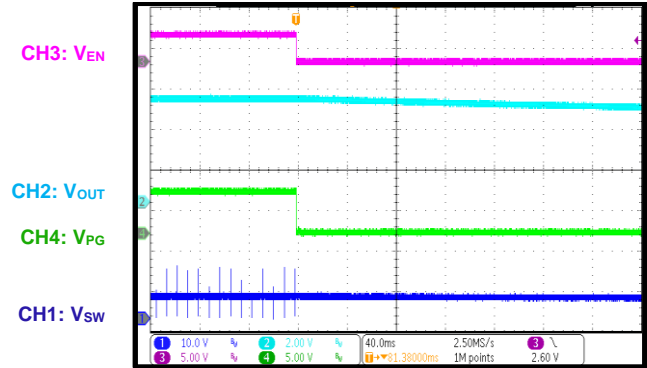
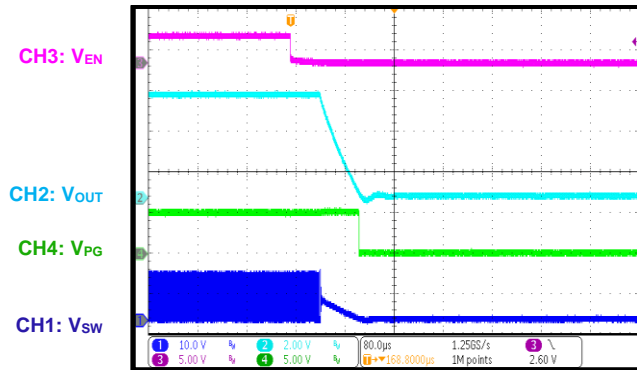
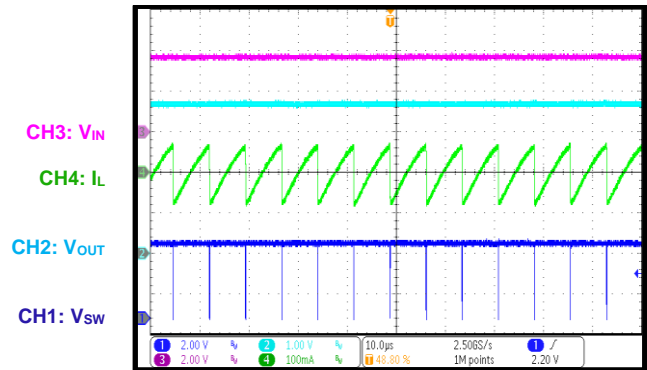
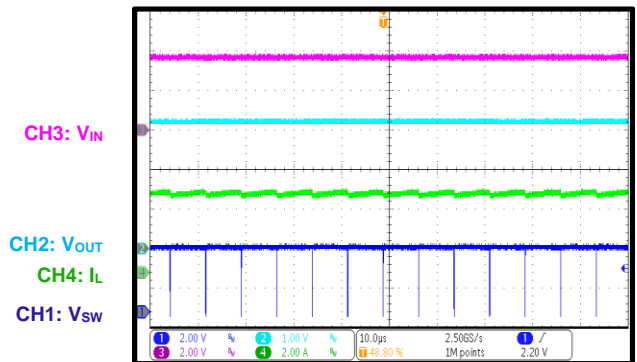
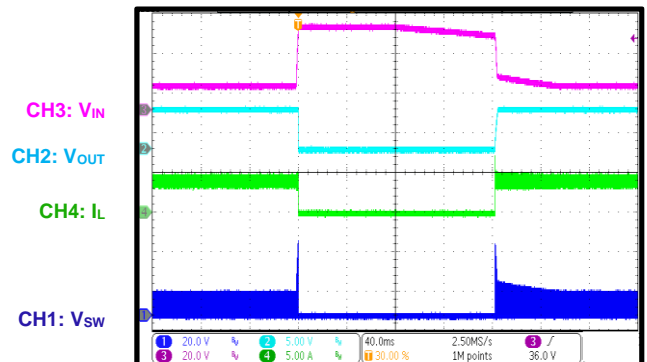
Load Transient
 $I_{OUT} = 2A$ to $4A$, $2A/\mu s$

SYNCIN Operation
 $I_{OUT} = 4A$, $f_{SYNC} = 1600kHz$

TYPICAL PERFORMANCE CHARACTERISTICS (continued)
 $V_{IN} = 12V$, $V_{OUT} = 5V$, $L = 1\mu H$, $f_{SW} = 2.2MHz$, AAM mode, $T_A = 25^\circ C$, unless otherwise noted.

SYNCIN Operation
 $I_{OUT} = 4A$, $f_{SYNC} = 2500kHz$

PG Start-Up through VIN
 $I_{OUT} = 0A$, AAM mode

PG Start-Up through VIN
 $I_{OUT} = 4A$

PG Shutdown through VIN
 $I_{OUT} = 0A$, AAM mode

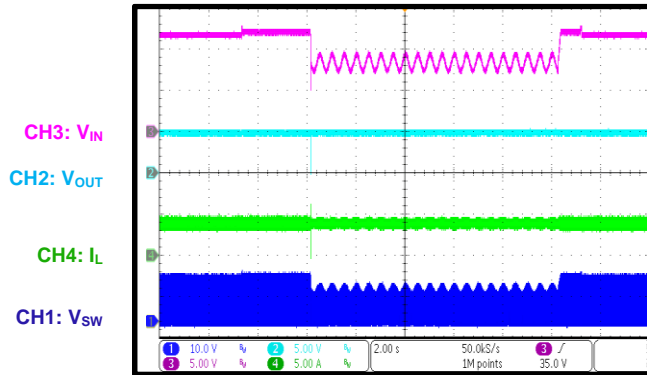
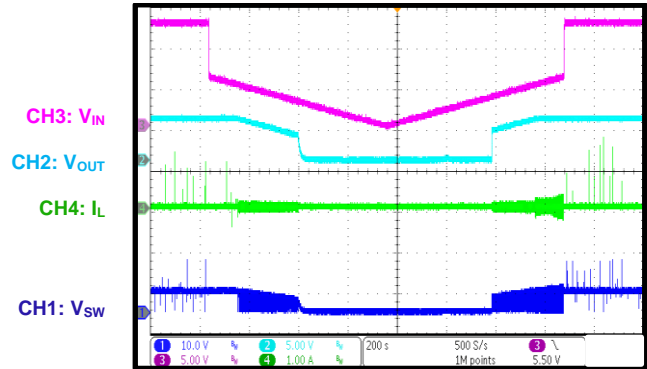
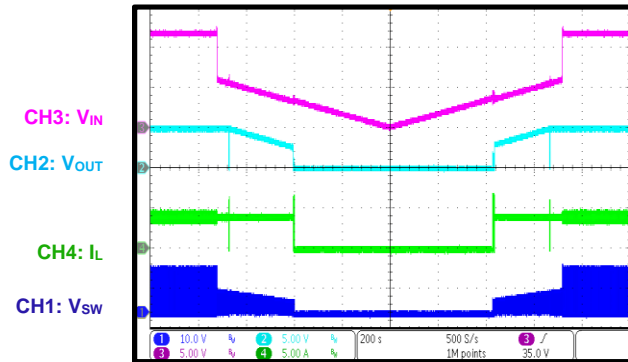
PG Shutdown through VIN
 $I_{OUT} = 4A$

PG Start-Up through EN
 $I_{OUT} = 0A$

TYPICAL PERFORMANCE CHARACTERISTICS (continued)
 $V_{IN} = 12V$, $V_{OUT} = 5V$, $L = 1\mu H$, $f_{SW} = 2.2MHz$, AAM mode, $T_A = 25^{\circ}C$, unless otherwise noted.

PG Start-Up through EN
 $I_{OUT} = 4A$

PG Shutdown through EN
 $I_{OUT} = 0A$

PG Shutdown through EN
 $I_{OUT} = 4A$

Low-Dropout Mode
 $V_{IN} = 3.7V$, $I_{OUT} = 0A$

Low-Dropout Mode
 $V_{IN} = 3.7V$, $I_{OUT} = 4A$

Load Dump
 $V_{IN} = 12V$ to $42V$, $I_{OUT} = 4A$

TYPICAL PERFORMANCE CHARACTERISTICS (continued)
 $V_{IN} = 12V$, $V_{OUT} = 5V$, $L = 1\mu H$, $f_{SW} = 2.2MHz$, AAM mode, $T_A = 25^\circ C$, unless otherwise noted.

Cold Crank
 $V_{IN} = 12V$ to 3.3V to 5V, $I_{OUT} = 4A$

 V_{IN} Ramping Down and Up
 $I_{OUT} = 0A$, AAM mode

 V_{IN} Ramping Down and Up
 $I_{OUT} = 4A$

FUNCTIONAL BLOCK DIAGRAMS

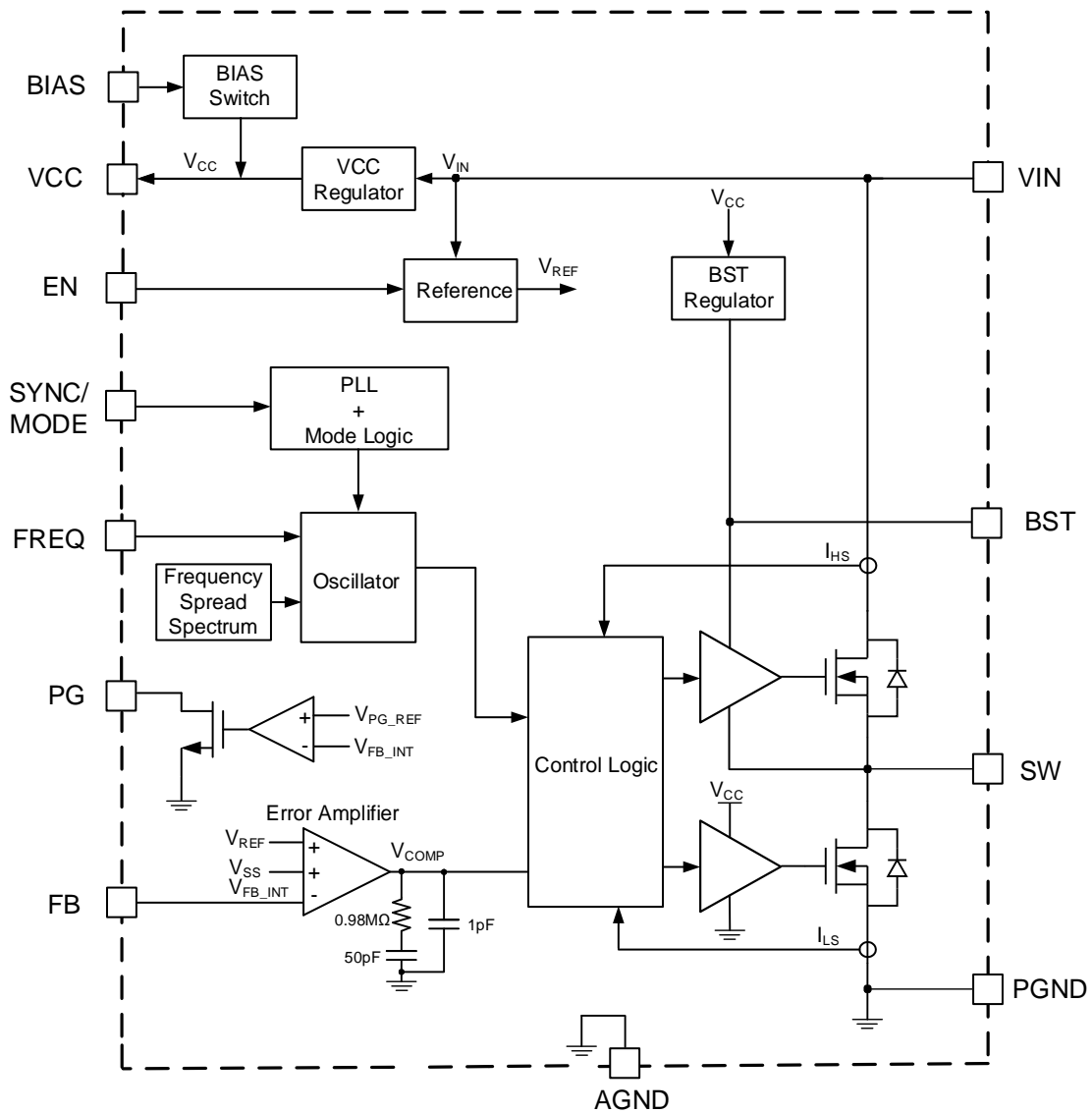
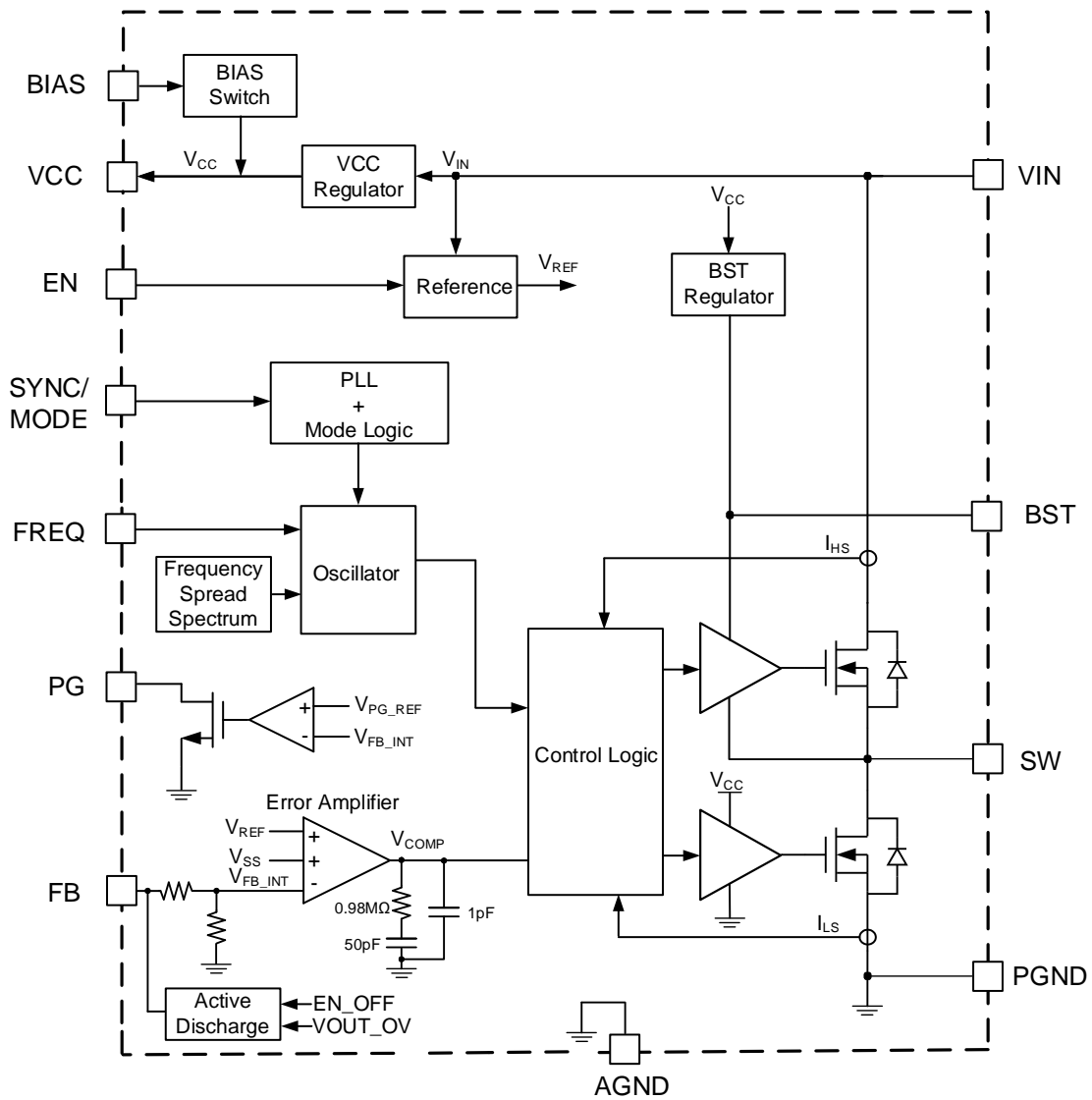

Figure 3: Functional Block Diagram (Adjustable Output)

FUNCTIONAL BLOCK DIAGRAMS (continued)

Figure 4: Functional Block Diagram (Fixed Output)

OPERATION

The MPQ4328 is a synchronous, step-down switching converter with an integrated internal high-side MOSFET (HS-FET) and low-side MOSFET (LS-FET). It provides up to 4A of highly efficient output current (I_{OUT}) with peak current mode control.

The MPQ4328 features wide input voltage (V_{IN}) range, configurable 200kHz to 2.5MHz switching frequency (f_{SW}), internal soft start (SS), and precision current limit (I_{LIMIT}). Its very low operational quiescent current (I_Q) makes the MPQ4328 well-suited for battery-powered applications.

Pulse-Width Modulation (PWM) Control

At moderate to high output currents, the MPQ4328 operates with fixed-frequency, peak current mode control to regulate the output voltage (V_{OUT}). A pulse-width modulation (PWM) cycle is initiated by the internal clock. At the clock's rising edge, the HS-FET turns on and remains on until the control signal reaches the value set by the internal COMP voltage (V_{COMP}).

If the HS-FET is off, the LS-FET turns on immediately and remains on until the next cycle starts or the inductor current (I_L) drops below the zero-current detection (ZCD) threshold. The LS-FET remains off for at least the minimum off time (t_{OFF_MIN}) before the next cycle starts.

If the HS-FET current does not reach the value set by V_{COMP} within one PWM period, the HS-FET remains on and skips a turn-off operation. The HS-FET is forced off until it reaches the value set by V_{COMP} , or once its 7 μ s maximum on time (t_{ON_MAX}) is reached. This mode extends the duty cycle, which achieves low dropout when $V_{IN} \approx V_{OUT}$.

Mode Selection and Light-Load Operation

The MPQ4328 provides forced continuous conduction mode (FCCM), advanced asynchronous modulation (AAM) mode, and on the fly mode selection (see Figure 5).

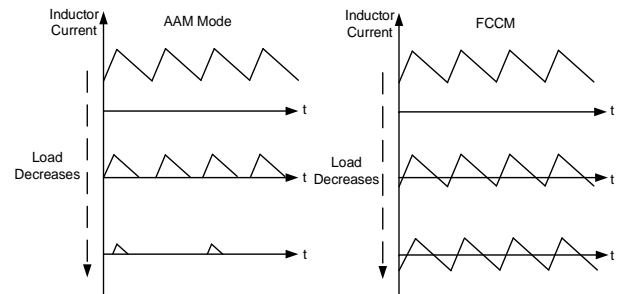

Figure 5: AAM Mode and FCCM

Under light-load conditions, the MPQ4328 can operate in two different modes by setting the state of the SYNC/MODE pin.

If SYNC/MODE is pulled above 1.4V or an external clock is used, then the MPQ4328 operates in FCCM. In FCCM, the device works with a fixed frequency from no-load to full-load conditions. The advantage of FCCM is the constant frequency and lower output ripple at light loads.

If SYNC/MODE is pulled below 0.4V, then the MPQ4328 operates in AAM mode, which optimizes efficiency under light-load and no-load conditions.

The MPQ4328 enters asynchronous operation as I_L approaches 0A under light-load conditions. If the load decreases further, V_{COMP} drops to its set value, and the device enters AAM mode. In AAM mode, the internal clock resets once V_{COMP} reaches its set value. The crossover time is used as a benchmark for the next clock. If the load increases and V_{COMP} exceeds its set value, the device operates in discontinuous conduction mode (DCM) or continuous conduction mode (CCM) with a constant f_{SW} .

Error Amplifier (EA)

The error amplifier (EA) compares the FB pin voltage (V_{FB}) with the internal reference (V_{REF}) (typically 0.8V) and outputs a current proportional to the difference between the two voltages. This current charges the compensation network to form V_{COMP} , which controls the power MOSFET's duty cycle.

During normal operation, the minimum V_{COMP} is clamped at 0.9V, and the maximum V_{COMP} is clamped at 2V. If the IC shuts down, V_{COMP} is internally pulled down to ground.

Frequency Spread Spectrum (FSS)

The MPQ4328 employs a 7.5kHz modulation frequency with a 128-step triangular profile to spread the internal oscillator frequency across a 20% ($\pm 10\%$) window. The steps vary with the set oscillator frequency to ensure that the exact f_{SW} steps cycle by cycle (see Figure 6).

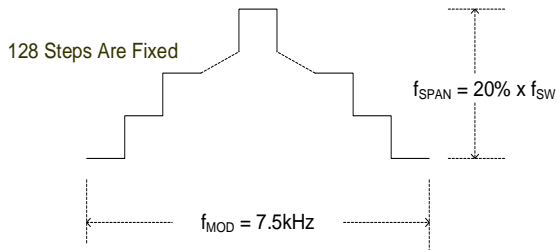

Figure 6: Frequency Spread Spectrum

Side-bands are created by modulating the switching frequency with the triangle modulation waveform. The emission power of the fundamental switching frequency and its harmonics is distributed into smaller pieces. Thus, the peak EMI noise is reduced significantly.

Low-Dropout Operation

To improve dropout, the MPQ4328 is designed to operate at close to 100% duty cycle when the BST-to-SW voltage exceeds 2.7V.

Once the device exits low-dropout mode, it initiates an SS to restart the part and prevent V_{COMP} from rising too high during this period. Even if V_{IN} increases rapidly, inductive voltage spikes are also minimized.

The effective duty cycle during the converter's dropout period is mainly influenced by the voltage drops across the power MOSFET, the inductor resistance, the low-side (LS) diode, and the PCB resistance.

Soft Start (SS)

Soft start (SS) prevents V_{OUT} from overshooting during start-up, where the SS time (t_{SS}) is fixed internally.

Once t_{SS} starts, the SS voltage (V_{SS}) rises from 0V to 1.2V with a set slew rate. If V_{SS} drops below the 0.8V internal reference voltage (V_{REF}), then V_{SS} takes over and the EA uses V_{SS} as its reference. If V_{SS} exceeds V_{REF} , the EA uses V_{REF} as its reference.

During t_{SS} , the converter operates in AAM mode for a smooth SS regardless of the MODE setting.

When the chip is enabled by EN, the first pulse will come after $\sim 710\mu s$. During this period, V_{CC} is regulated, internal bias and charging of the compensator network are completed. After another 2.9ms, V_{OUT} ramp up and reaches the set value. Then the entire soft start will be completed after 2.3ms. PG will also be pulled high after a 160 μs deglitch.

Pre-Biased Start-Up

If V_{FB} exceeds V_{SS} during start-up ($V_{FB} > V_{SS} - 150mV$), this means that the output has a pre-biased voltage. Both the HS-FET and LS-FET remain off until V_{SS} exceeds V_{FB} .

V_{IN} Over-Voltage Protection (OVP)

The MPQ4328 can operate across a wide V_{IN} range up to 36V. If V_{IN} exceeds its over-voltage protection (OVP) rising threshold ($V_{IN_OVP_RISING}$) (typically 38V), then the device stops switching. If V_{IN} drops to the OVP falling threshold (typically 37V), then the device resumes switching and normal regulation. This ensures the device can survive in load dump conditions up to 42V.

Thermal Shutdown

Thermal shutdown is implemented to prevent the chip from thermally running away. When the silicon die temperature exceeds its upper threshold (170°C), the power MOSFETs shut down. When the temperature is lower than its lower threshold 150°C, thermal shutdown is gone so the chip is enabled again.

Start-Up and Shutdown

If both V_{IN} and the EN voltage (V_{EN}) exceed their respective thresholds, the device starts up. The reference block starts up first to generate a stable V_{REF} and reference currents. Then the internal regulator is enabled to provide a stable supply for the remaining circuitry.

Once the internal supply rail is up, the LS-FET turns on to charge the BST pin if the voltage between BST and SW (V_{BST-SW}) does not exceed the BST refresh rising threshold (typically 2.7V). The HS-FET remains off during this time. When the soft-start block is enabled, it first holds its soft-start output low to ensure that the remaining circuits are ready. Then the soft-start block slowly ramps up.

Three events shut down the chip: EN going low, V_{IN} falling below its under-voltage lockout (UVLO) threshold, and thermal shutdown. During shutdown, the signaling path is blocked to avoid any fault triggering. Then V_{COMP} is pulled down and the floating driver disables the HS-FET.

APPLICATION INFORMATION

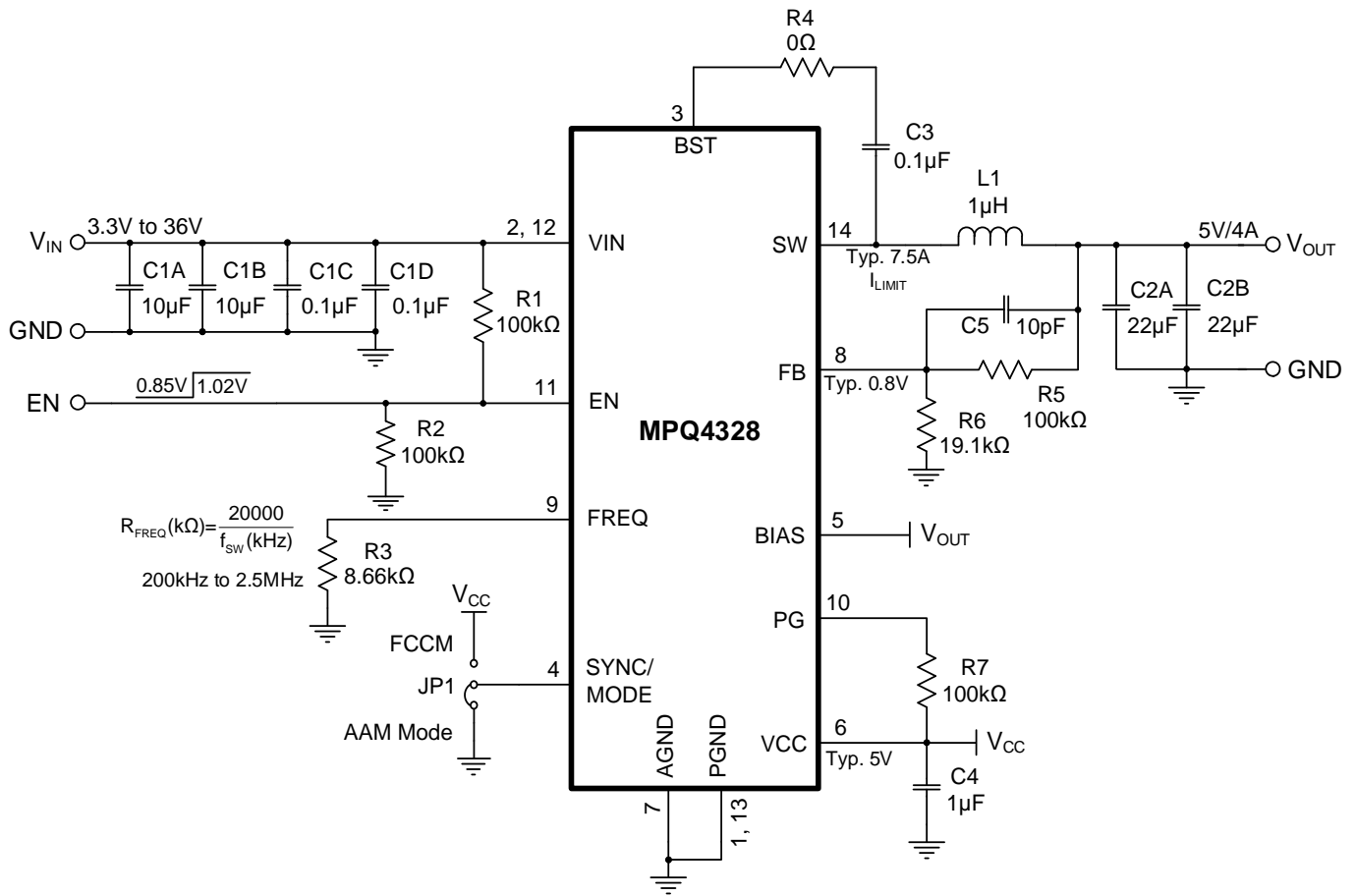

Figure 7: Typical Application Circuit ($V_{OUT} = 5V$, $f_{sw} = 2.2MHz$)

Table 1: Design Guide Index

Pin #	Pin Name	Component	Design Guide Index
1, 13	PGND	-	Ground Connection (PGND, Pins 1 and 13; AGND, Pin 7)
2, 12	VIN	C1A, C1B, C1C, C1D	Selecting the Input Capacitors (VIN, Pins 2 and 12)
3	BST	R4, C3	Floating Driver and Bootstrap Charging (BST, Pin 3)
4	SYNC/ MODE	-	Synchronous Input and Mode Selection (SYNC/MODE, Pin 4)
5	BIAS	-	External Bias for Low Quiescent Current (BIAS, Pin 5)
6	VCC	C4	Internal Bias Supply (VCC, Pin 6)
7	AGND	-	Ground Connection (PGND, Pins 1 and 13; AGND, Pin 7)
8	FB	R5, R6, C5	Feedback (FB, Pin 8)
9	FREQ	R3	Setting the Switching Frequency (f_{sw}) (FREQ, Pin 9)
10	PG	R7	Power Good (PG) Indicator (PG, Pin 10)
11	EN	R1, R2	Enable (EN) and Under-Voltage Lockout (UVLO) (EN, Pin 11)
14	SW	L1, C2A, C2B	Selecting the Inductor and Output Capacitors (SW, Pin 14)

Ground Connection (PGND, Pins 1 and 13; AGND, Pin 7)

See the PCB Layout Guidelines section on page 43 for more details.

Selecting the Input Capacitors (VIN, Pins 2 and 12)

The step-down converter has a discontinuous input current (I_{IN}) and requires a capacitor to supply AC current to the converter while maintaining the DC V_{IN}. Use low-ESR capacitors for the best performance. Ceramic capacitors with X5R or X7R dielectrics are highly recommended due to their low ESR and small temperature coefficients.

For most applications, a 4.7μF to 10μF capacitor is sufficient. It is strongly recommended to use an additional, lower-value capacitor (e.g. 0.1μF) with a small package size (0603) to absorb high-frequency switching noise. Place the smaller capacitor as close to VIN and PGND as possible.

Since the input capacitor (C_{IN}) absorbs the input switching current, it requires an adequate ripple current rating. The RMS current in C_{IN} (I_{CIN}) can be estimated with Equation (1):

$$I_{CIN} = I_{LOAD} \times \sqrt{\frac{V_{OUT}}{V_{IN}} \times \left(1 - \frac{V_{OUT}}{V_{IN}}\right)} \quad (1)$$

The worst-case condition occurs at V_{IN} = 2 × V_{OUT}, which can be calculated with Equation (2):

$$I_{CIN} = \frac{I_{LOAD}}{2} \quad (2)$$

For simplification, choose C_{IN} with an RMS current rating greater than half of the maximum load current (I_{LOAD_MAX}). C_{IN} can be electrolytic, tantalum, or ceramic. When using electrolytic or tantalum capacitors, add a small, high-quality ceramic capacitor (e.g. 0.1μF) as close to the IC as possible. When using ceramic capacitors, ensure that they have enough capacitance to provide a sufficient charge to prevent excessive voltage ripple at the input. The input voltage ripple (ΔV_{IN}) caused by the capacitance can be estimated with Equation (3):

$$\Delta V_{IN} = \frac{I_{LOAD}}{f_{SW} \times C_{IN}} \times \frac{V_{OUT}}{V_{IN}} \times \left(1 - \frac{V_{OUT}}{V_{IN}}\right) \quad (3)$$

Floating Driver and Bootstrap Charging (BST, Pin 3)

The bootstrap (BST) capacitor (C₃, also called C_{BST}) is recommended to be between 0.1μF and 0.22μF.

It is not recommended to place a resistor (R_{BST}) in series with C_{BST}, unless there is a strict EMI requirement. R_{BST} reduces EMI and voltage stress at high input voltages. A higher resistance is better for switching spike reduction but compromises efficiency. If necessary, R_{BST} should be less than 5Ω.

The voltage between the BST and SW pins (V_{BST-SW}) is regulated to about 5V by the dedicated internal BST regulator. If V_{BST-SW} drops below its regulated value, then an N-channel MOSFET pass transistor connected between VCC and BST turns on to charge C_{BST}. The external circuit should provide enough voltage headroom to facilitate charging.

When the HS-FET is on, V_{BST} exceeds V_{CC} and C_{BST} cannot charge. At a higher duty cycle, the time available for BST charging is shorter, so C_{BST} may not be charged sufficiently. If the external circuit has an insufficient voltage and time to charge C_{BST}, additional external circuitry can be used to ensure that V_{BST} remains within its normal operating region.

If V_{BST} reaches its UVLO threshold, then the HS-FET turns off, and the LS-FET turns on for t_{OFF_MIN} to refresh V_{BST} via the set f_{SW}.

Synchronous Input and Mode Selection (SYNC/MODE, Pin 4)

f_{SW} can be synchronized to the rising edge of a clock signal applied at SYNC/MODE. The recommended SYNCIN frequency range is between 200kHz and 2.5MHz.

Switching can be synchronized to an external clock within a SYNCIN clock locking time (128 cycles), ranging from ±10% of the set clock frequency.

When SYNC/MODE is used for mode selection, pull this pin high to allow the part to enter FCCM; pull this pin low to allow the part to enter AAM mode. Table 2 on page 40 shows the details for mode selection.

Table 2: Mode Selection

SYNC/MODE Input	Operation
<0.4V	AAM mode
>1.4V	FCCM
External clock in	FCCM

External Bias for Low Quiescent Current (BIAS, Pin 5)

BIAS is the external bias pin. When BIAS is connected to a 5V voltage, the internal LDO turns off, and a smaller input supply current enables higher efficiency. If the BIAS pin voltage (V_{BIAS}) exceeds 4.6V, the pin starts to work; if V_{BIAS} drops below 4.36V, the pin is disabled. For the 5V output version, connect BIAS to V_{OUT} directly. For the other lower (<4.6V) or higher (>6V) output versions, connect BIAS to an external 5V source to achieve a lower input supply current, or connect BIAS to ground to disable the external bias. It is recommended to avoid providing V_{BIAS} before V_{IN} .

Internal Bias Supply (VCC, Pin 6)

The VCC capacitor (C4) is recommended to be 1 μ F.

Most of the internal circuitry is powered by the internal 5V VCC regulator. This regulator uses V_{IN} as its input and operates across the entire V_{IN} range. If V_{IN} exceeds 5V, then V_{CC} is in full regulation. If V_{IN} drops below 5V, then the VCC output degrades.

Feedback (FB, Pin 8)

For the adjustable-output version, the typical feedback (FB) voltage (V_{FB}) is 0.8V. The external resistor divider (R5 and R6) connected to FB sets V_{OUT} (see Figure 8).

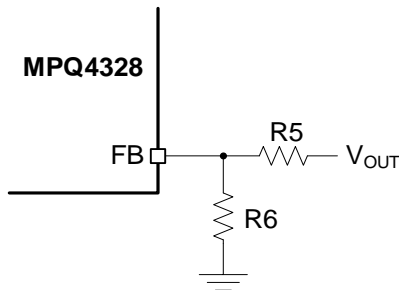
Figure 8: Feedback Divider Network for Adjustable-Output Version

R6 can be calculated with Equation (4):

$$R6 = \frac{R5}{\frac{V_{OUT}}{0.8V} - 1} \quad (4)$$

Table 3 lists the recommended FB resistances for common output voltages.

Table 3: Resistor Selection for Output Voltages

V_{OUT} (V)	R5 (k Ω)	R6 (k Ω)
3.3	100 (0.1%)	31.6 (0.1%)
5	100 (0.1%)	19.1 (0.1%)

For the fixed-output version, the FB resistor divider (R_{FB1} and R_{FB2}) are integrated internally (see Figure 9). Connect FB directly to the output to set V_{OUT} . The following fixed outputs can be selected: 1V, 1.8V, 2.5V, 3V, 3.3V, 3.8V, or 5V.

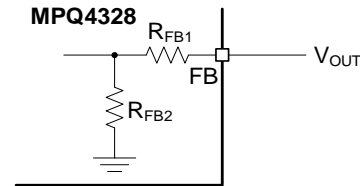

Figure 9: Feedback Divider Network for Fixed-Output Version

Table 4 shows the relationship between the internal R_{FB} and V_{OUT} .

Table 4: R_{FB} vs. V_{OUT}

V_{OUT} (V)	R_{FB1} (k Ω)	R_{FB2} (k Ω)
1	64	256
1.8	320	256
2.5	544	256
3.0	704	256
3.3	800	256
3.8	960	256
5	1344	256

Setting the Switching Frequency (f_{sw}) (FREQ, Pin 9)

A frequency resistor (R3, also called R_{FREQ}) can be used to set f_{sw} (see Figure 10 on page 40).

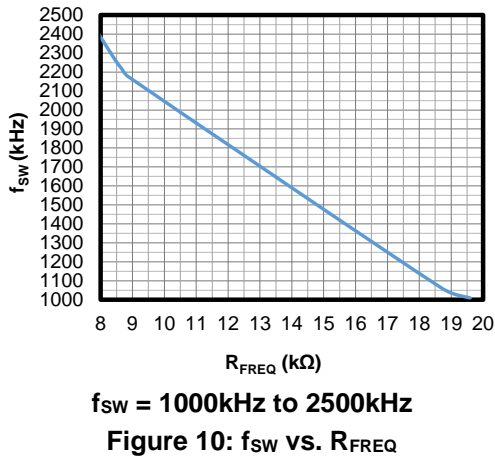
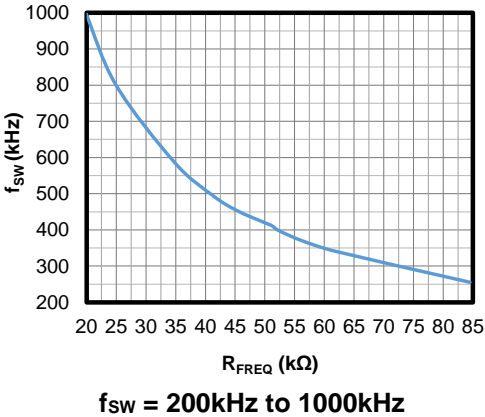

Figure 10: f_{sw} vs. R_{FREQ}

Table 5 shows the relationship between f_{sw} and R_{FREQ}.

Table 5: f_{sw} vs. R_{FREQ}

R _{FREQ} (kΩ)	f _{sw} (kHz)
7.87	2500
8.66	2200
14.3	1500
18.7	1060
19.6	1000
24.9	800
34.8	590
43.2	470
49.9	410
52.3	400
56.2	370
62	340
84.5	255
100	210

Power Good (PG) Indicator (PG, Pin 10)

The PG resistor (R7, also called R_{PG}) is recommended to have a resistance of about 100kΩ.

The MPQ4328 includes an open-drain power good (PG) output that indicates whether V_{OUT} is

within a specific window of its nominal range.

If PG is used, connect it to a logic high power source in the system via a pull-up resistor. If V_{OUT} is within 94.5% to 105.5% of the nominal voltage, PG goes high; if V_{OUT} exceeds 107% or drops below 93% of the nominal voltage, PG goes low. Float PG if it is not used.

Enable (EN) and Under-Voltage Lockout (UVLO) (EN, Pin 11)

EN is a digital control pin that turns the converter on and off.

Enabled by an External Logic High/Low Signal

If V_{EN} reaches about 0.7V, the bandgap (BG) does not turn on until V_{IN} exceeds about 2.7V. The BG then provides an accurate V_{REF} for the EN threshold. Pull EN above its rising threshold (1.02V) to enable the device. Pull EN below 0.85V to shut down the device. There is no internal pull-up or pull-down resistor connected to EN. Do not float EN to avoid uncertain states. If the control signal cannot give an accurate high or low logic, then an external pull-up or pull-down resistor is required.

Configurable V_{IN} Under-Voltage Lockout (UVLO) Threshold

The MPQ4328 has an internal, fixed UVLO threshold. The rising threshold is 3.7V, and the falling threshold is about 2.9V. For applications that require a higher UVLO level, place an external resistor divider between V_{IN} and EN to raise the equivalent UVLO threshold (see Figure 11).

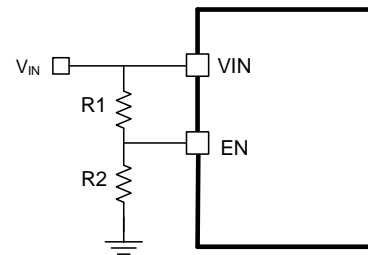

Figure 11: Adjustable UVLO via the EN Divider

The UVLO rising threshold (V_{IN_UVLO_RISING}) can be calculated with Equation (5):

$$V_{IN_UVLO_RISING} = \left(1 + \frac{R1}{R2}\right) \times V_{EN_RISING} \quad (5)$$

Where V_{EN_RISING} is 1.02V.

The UVLO falling threshold ($V_{IN_UVLO_FALLING}$) can be calculated with Equation (6):

$$V_{IN_UVLO_FALLING} = \left(1 + \frac{R1}{R2}\right) \times V_{EN_FALLING} \quad (6)$$

Where $V_{EN_FALLING}$ is 0.85V.

If EN is not used to turn the device on and off, connect EN to a high-voltage source (e.g. VIN) to turn the device on by default.

Selecting the Inductor and Output Capacitors (SW, Pin 14)

The inductance ($L1$) can be calculated with Equation (7):

$$L1 = \frac{V_{OUT}}{f_{SW} \times \Delta I_L} \times \left(1 - \frac{V_{OUT}}{V_{IN}}\right) \quad (7)$$

Where ΔI_L is the peak-to-peak inductor ripple current.

A 1 μ H to 10 μ H inductor with a DC current rating at least 25% higher I_{LOAD_MAX} is recommended for most applications. For higher efficiency, choose an inductor with a lower DC resistance. A larger-value inductor results in less ripple current and a lower output ripple voltage; however, it also has a larger physical size, higher series resistance, and lower saturation current. A small-size inductor also provides benefits for EMI. A good rule for determining the inductance is to allow the inductor ripple current to be approximately 30% of I_{LOAD_MAX} .

The peak inductor current (I_{L_PEAK}) can be calculated with Equation (8):

$$I_{L_PEAK} = I_{LOAD} + \frac{V_{OUT}}{2 \times f_{SW} \times L1} \times \left(1 - \frac{V_{OUT}}{V_{IN}}\right) \quad (8)$$

Choose an inductor that does not saturate under I_{L_PEAK} .

Peak and Valley Current Limits

Both the HS-FET and LS-FET have cycle-by-cycle I_{LIMIT} protection. If I_L reaches the high-side (HS) peak I_{LIMIT} (typically 7.5A) while the HS-FET is on, then the HS-FET is immediately forced off to prevent the current from rising further.

When the LS-FET is on, the next clock's rising edge is held until I_L drops below the LS valley I_{LIMIT} (typically 5A). Once the HS-FET turns on

again, I_L drops to a sufficiently low value. This I_{LIMIT} scheme prevents current runaway if an overload or short-circuit event occurs.

Short-Circuit Protection (SCP)

If the output is shorted to ground, and V_{OUT} drops below 70% of its nominal output, then the MPQ4328 shuts down momentarily and discharge V_{SS} . Once V_{SS} is fully discharged, the device initiates an SS. This hiccup process is repeated until the fault is removed.

During the hiccup period, if V_{FB} reaches 50% of the internal V_{REF} , the device triggers the SCP recovery action and initiates an SS to avoid large spikes. When applying SCP function, V_{IN} is recommended to be lower than 24V.

The output voltage ripple (ΔV_{OUT}) can be estimated with Equation (9):

$$\Delta V_{OUT} = \frac{V_{OUT}}{f_{SW} \times L1} \times \left(1 - \frac{V_{OUT}}{V_{IN}}\right) \times \left(R_{ESR} + \frac{1}{8 \times f_{SW} \times C_{OUT}}\right) \quad (9)$$

Where R_{ESR} is the equivalent series resistance (ESR) of the output capacitor (C_{OUT}).

C_{OUT} maintains the DC V_{OUT} . Use ceramic, tantalum, or low-ESR electrolytic capacitors. For the best results, use low-ESR capacitors to keep ΔV_{OUT} low.

For ceramic capacitors, the capacitance dominates the impedance at f_{SW} and causes the majority of ΔV_{OUT} . For simplification, ΔV_{OUT} can be estimated with Equation (10):

$$\Delta V_{OUT} = \frac{V_{OUT}}{8 \times f_{SW}^2 \times L1 \times C_{OUT}} \times \left(1 - \frac{V_{OUT}}{V_{IN}}\right) \quad (10)$$

For tantalum or electrolytic capacitors, the ESR dominates the impedance at f_{SW} . For simplification, ΔV_{OUT} can be estimated with Equation (11):

$$\Delta V_{OUT} = \frac{V_{OUT}}{f_{SW} \times L1} \times \left(1 - \frac{V_{OUT}}{V_{IN}}\right) \times R_{ESR} \quad (11)$$

When selecting C_{OUT} , consider the allowable overshoot in V_{OUT} if the load is suddenly removed. In this scenario, energy stored in the inductor is transferred to C_{OUT} , causing its voltage to rise. To achieve an optimal overshoot relative to the regulated voltage, C_{OUT} can be estimated with Equation (12):

$$C_{OUT} = \frac{(I_{OUT})^2 \times L1}{(V_{OUT})^2 \times ((V_{OUT_MAX} / (V_{OUT})^2) - 1)} \quad (12)$$

Where V_{OUT_MAX} / V_{OUT} is the allowable maximum overshoot.

After calculating the capacitance that meets both the ripple and overshoot needs, choose the larger capacitance.

The C_{OUT} characteristics also affect the stability of the regulation system. The MPQ4328 can be optimized for a wide range of capacitances and ESR values.

Output Over-Voltage Protection (OVP) and Discharge

If V_{OUT} exceeds 130% of its nominal regulation value, the MPQ4328 stops switching. An internal 75Ω discharge path from FB to ground discharges V_{OUT} . This discharge path is only activated if the output is fixed. Once V_{OUT} drops back to 125% of its nominal voltage, the discharge path is disabled, and the device resumes switching.

For the fixed-output version, the V_{OUT} discharge path is also activated if a shutdown through EN occurs. Once V_{CC} drops to its UVLO threshold, the discharge path is disabled.

PCB Layout Guidelines ⁽¹⁵⁾

Efficient PCB layout, especially input capacitor placement, is critical for stable operation. A 4-layer layout is strongly recommended to achieve better thermal performance. For the best results, refer to Figure 12 and follow the guidelines below:

1. Place the symmetric input capacitors as close to VIN and PGND as possible.
2. Connect a large ground plane directly to PGND.
3. If the bottom layer is a ground plane, add vias near PGND.
4. Route the high-current paths at GND and VIN using short, direct, and wide traces.
5. Place the ceramic input capacitor, especially the small package size (0603) input bypass capacitor, as close to VIN and PGND as possible to minimize high-frequency noise.
6. Keep the connection between the input capacitor and VIN as short and wide as possible.
7. Place the VCC capacitor as close to VCC and AGND as possible.
8. Route SW and BST away from sensitive analog areas, such as FB.
9. Reduce the SW node routing size to reduce EMI.
10. Place the feedback resistors close to the IC to keep the FB trace as short as possible.
11. Use multiple vias to connect the power planes to the internal layers.

Note:

15) The recommended PCB layout is based on Figure 13 on page 44.

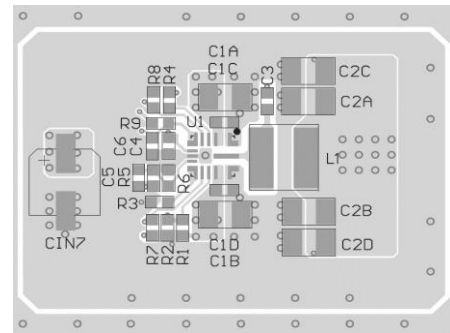
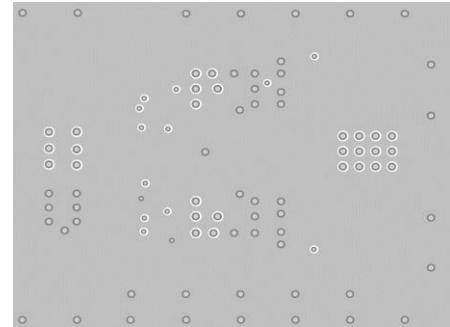
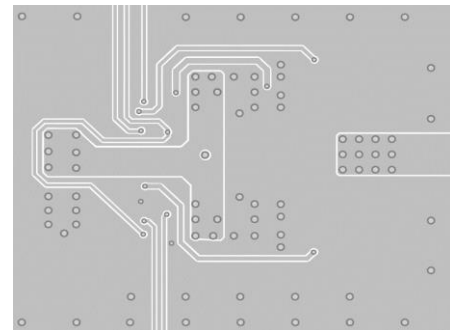
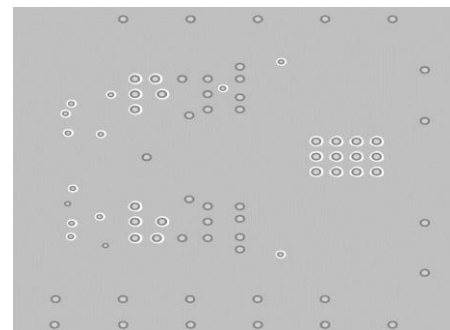
Top Layer

Mid-Layer 1

Mid-Layer 2

Bottom Layer
Figure 12: Recommended PCB Layout

TYPICAL APPLICATION CIRCUITS

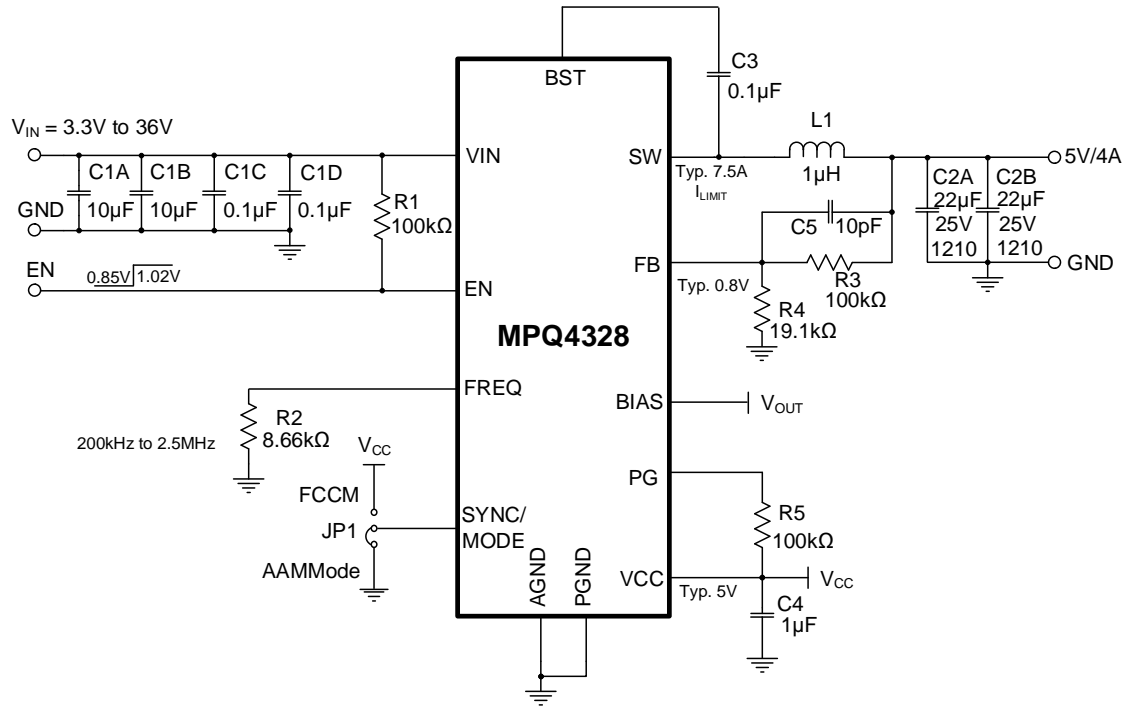

Figure 13: Typical Application Circuit ($V_{OUT} = 5V$, $f_{sw} = 2.2MHz$)

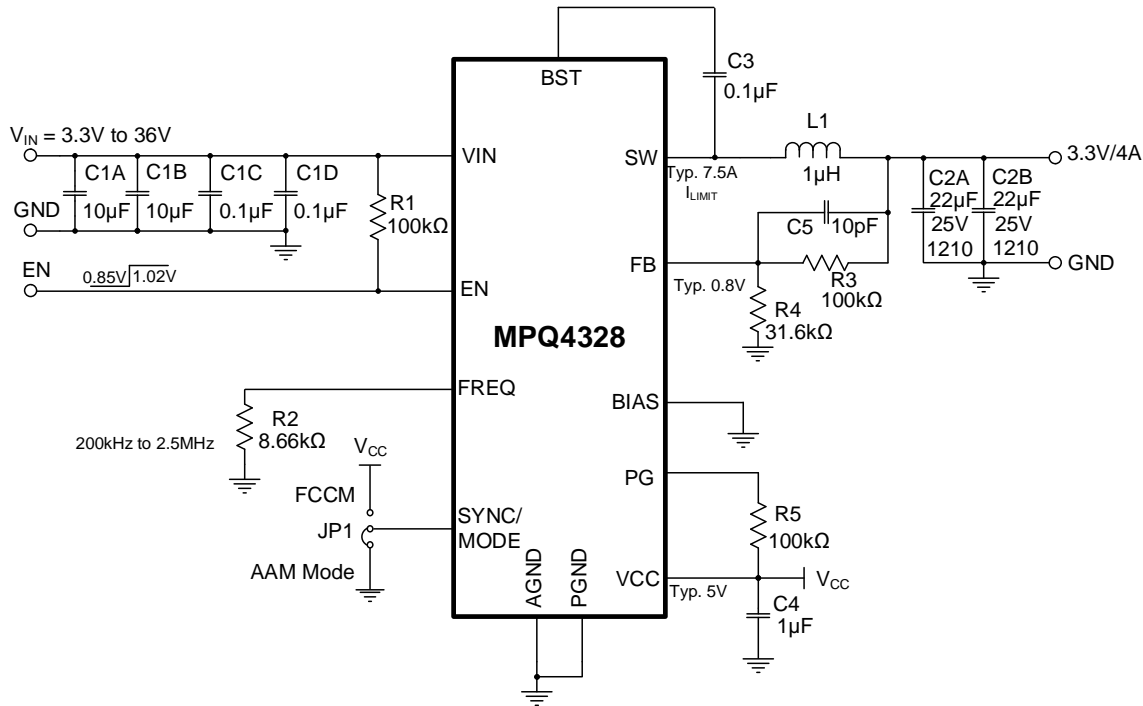
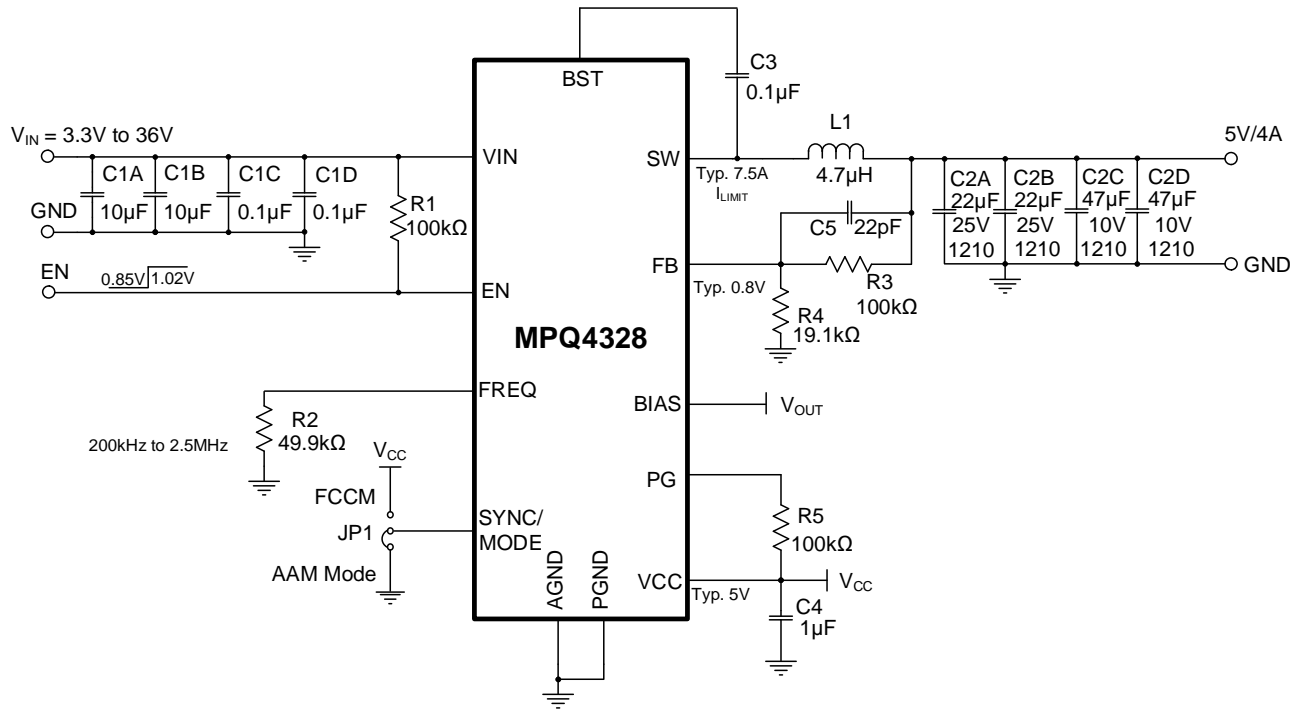
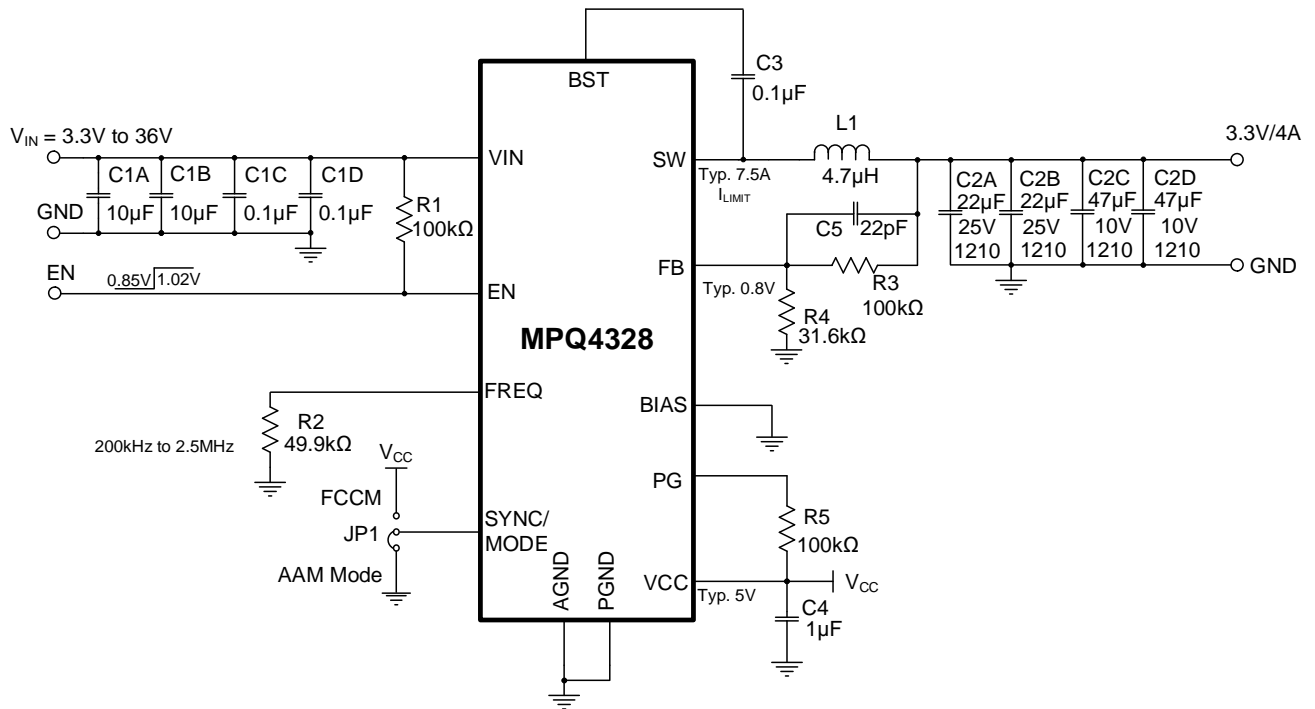

Figure 14: Typical Application Circuit ($V_{OUT} = 3.3V$, $f_{sw} = 2.2MHz$)

TYPICAL APPLICATION CIRCUITS (continued)

 Figure 15: Typical Application Circuit ($V_{OUT} = 5V$, $f_{sw} = 410kHz$)

 Figure 16: Typical Application Circuit ($V_{OUT} = 3.3V$, $f_{sw} = 410kHz$)

TYPICAL APPLICATION CIRCUITS (continued)

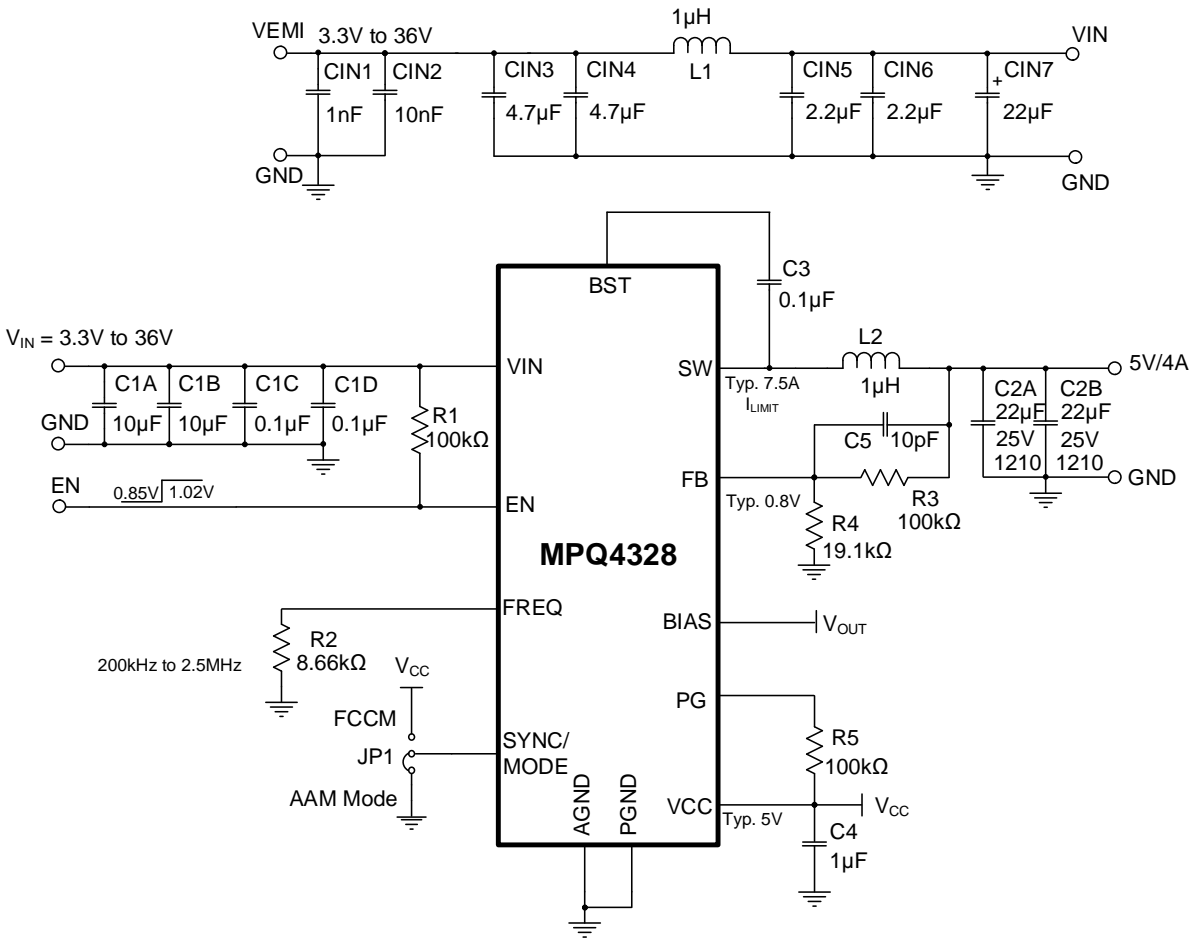
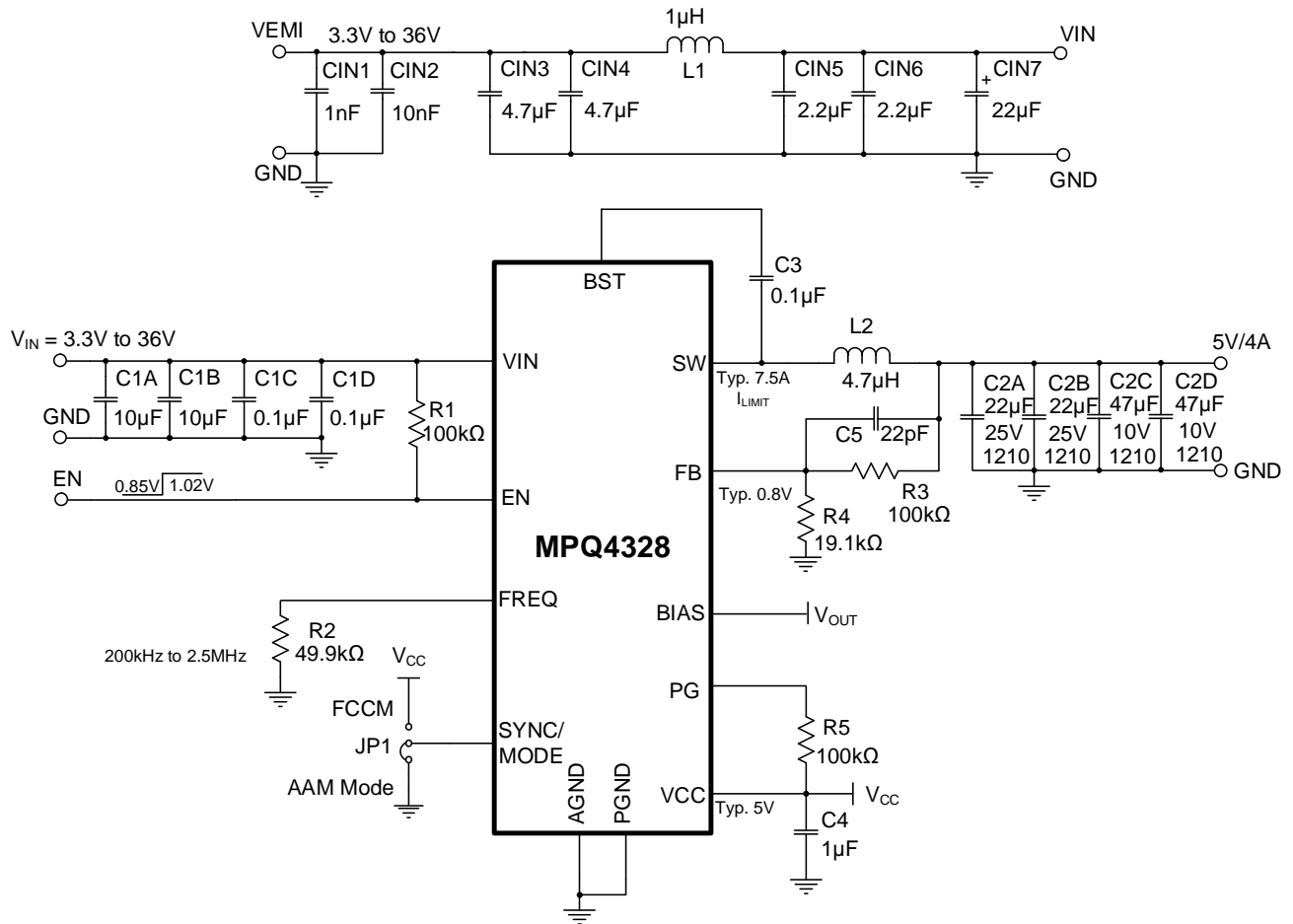
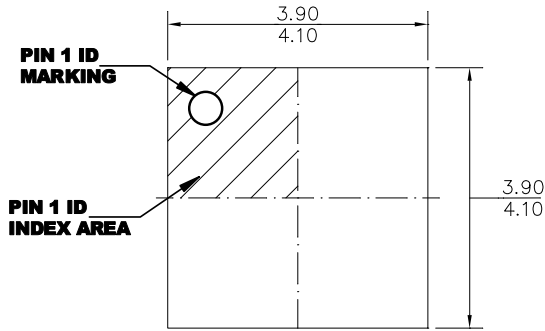

Figure 17: Typical Application Circuit with EMI Filters ($V_{OUT} = 5V$, $f_{sw} = 2.2MHz$)

TYPICAL APPLICATION CIRCUITS (continued)

Figure 18: Typical Application Circuit with EMI Filters ($V_{OUT} = 5V$, $f_{sw} = 410kHz$)

PACKAGE INFORMATION

QFN-14 (4mmx4mm) Wettable Flank

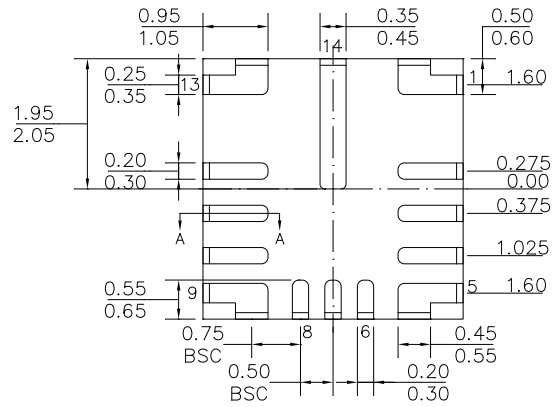

TOP VIEW



BOTTOM VIEW

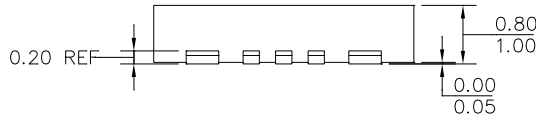

SIDE VIEW

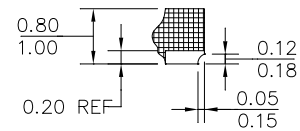

SECTION A-A

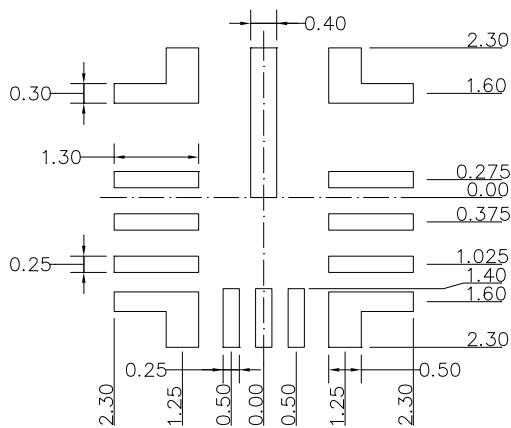

RECOMMENDED LAND PATTERN

NOTE:

- 1) THE LEAD SIDE IS WETTABLE.
- 2) ALL DIMENSIONS ARE IN MILLIMETERS.
- 3) LEAD COPLANARITY SHALL BE 0.08 MILLIMETERS MAX.
- 4) JEDEC REFERENCE IS MO-220.
- 5) DRAWING IS NOT TO SCALE.

CARRIER INFORMATION

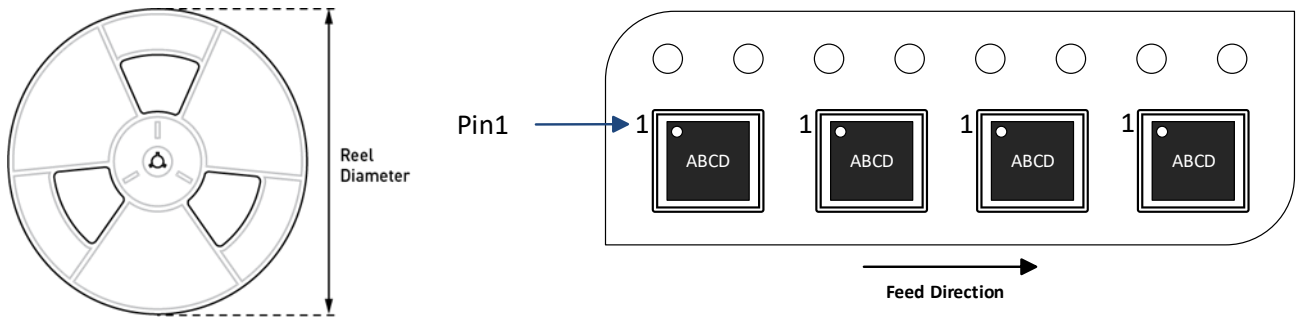

Part Number	Package Description	Quantity/ Reel	Quantity/ Tube ⁽¹⁶⁾	Quantity/ Tray ⁽¹⁶⁾	Reel Diameter	Carrier Tape Width	Carrier Tape Pitch
MPQ4328GRE-AEC1-Z	QFN-14 (4mmx4mm)	5000	N/A	N/A	13in	12mm	8mm
MPQ4328GRE-5-AEC1-Z	QFN-14 (4mmx4mm)	5000	N/A	N/A	13in	12mm	8mm

Note:

16) N/A indicates “not available” in tube and tray. For 500-piece tape & reel prototype quantities, please contact the factory. (The order code for a 500-piece partial reel is “-P”. Tape & reel dimensions are the same as the full reel.)



REVISION HISTORY

Revision #	Revision Date	Description	Pages Updated
1.0	8/30/2023	Initial Release	-

Notice: The information in this document is subject to change without notice. Please contact MPS for current specifications. Users should warrant and guarantee that third-party Intellectual Property rights are not infringed upon when integrating MPS products into any application. MPS will not assume any legal responsibility for any said applications.