

DESCRIPTION

The MP86912C is a monolithic half-bridge driver with built-in, internal power MOSFETs and gate drivers. It achieves 25A of continuous output current over a wide input supply range.

The integration of the driver and MOSFETs provides high efficiency due to an optimal dead time and parasitic inductance reduction. The MP86912C can operate from 100kHz to 2MHz.

The device works with tri-state output controllers and offers general-purpose current sense and temperature sense.

The MP86912C is ideal for notebook applications where efficiency and small sizes are a premium. It is available in an LGA (3mmx4mm) package.

FEATURES

- Wide Operating Input Range
- Compliant with Intel DrMOS V4.0 Spec
- 25A Output Current
- Accepts Tri-State PWM Signal
- Built-In Switch for Bootstrap
- Current Sense
- Temperature Sense
- Current-Limit Protection
- Over-Temperature Protection (OTP)
- Fault Reporting: Over-Current (OC) and Over-Temperature (OT)
- Used for Multi-Phase Operation
- Available in an LGA (3mmx4mm) Package

APPLICATIONS

- Notebook Core Voltage
- Graphic Card Core Regulators
- Power Modules

All MPS parts are lead-free, halogen-free, and adhere to the RoHS directive. For MPS green status, visit the MPS website under Quality Assurance. "MPS", the MPS logo, and "Simple, Easy Solutions" are trademarks of Monolithic Power Systems, Inc. or its subsidiaries.

TYPICAL APPLICATION

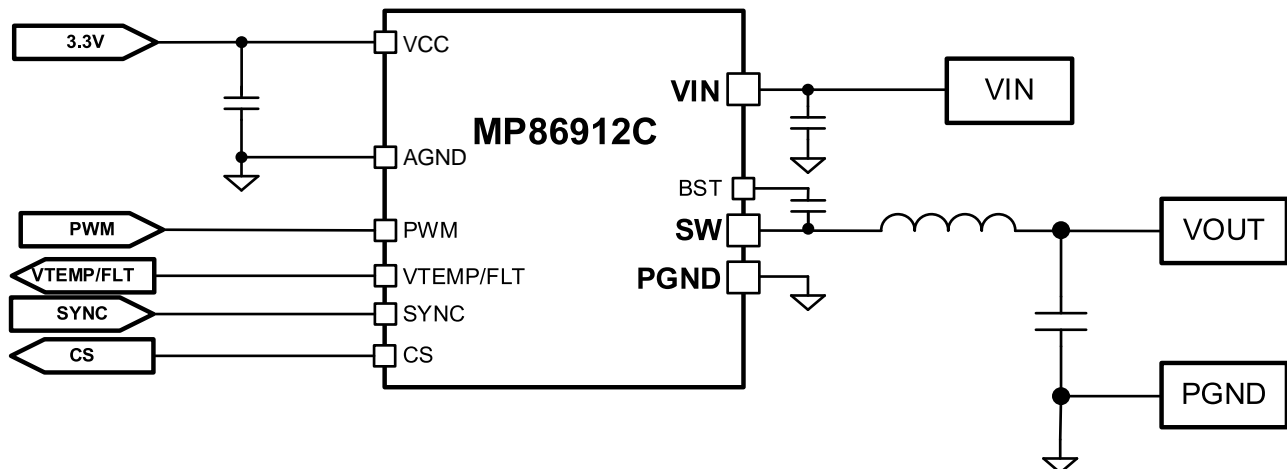

Notice: The information in this document is subject to change without notice. Please contact MPS for current specifications. Users should warrant and guarantee that third-party Intellectual Property rights are not infringed upon when integrating MPS products into any application. MPS will not assume any legal responsibility for any said applications.