



DESCRIPTION

The MP6710 is a high-performance motion controller incorporating proportion-integral-differential (PID) algorithms, a curve-planning algorithm, and rich protection functions. It is used for applications with three-phase PMSM and BLDC motors together with the MP6570 to achieve better dynamic response.

The operation of the MP6710 supports three modes: speed mode, position mode, and torque mode. The reference command comes from either the digital interface or the PULSE/DIR input pin. A 12-bit ADC is employed for accurate sampling of the DC voltage and temperature.

Non-volatile memory is employed in the MP6710 to store parameters programmed through the selectable RS485 digital interface.

Application design is aided by MPS's eMotion System™ Virtual Bench online developer tool.

Robust failure protection modes include over-current protection, long-time overload protection, rotor-lock protection, and input bus over-voltage and over-current protection.

The MP6710 is available in a TQFN-32 (4mmx4mm) package.

FEATURES

- 3.3V Operating Supply Voltage
- Flexible Parameter Configuration with Non-Volatile Memory
- Selectable RS485/External IO Interface
- Three-Loop Control
- Good Dynamic Performance
- Position/Speed/Torque Operation Modes
- PWM/Pulse/Digital Interface Reference Input
- Energy Regeneration Braking Mode
- 12-Bit ADC
- Up to 80kHz Programmable Switching Frequency
- Up to 127 Programmable Slave Addresses
- Input Bus UVLO and Over-Voltage Protection
- Over-Current Protection
- Locked Rotor Detection and Restart
- Programmable Speed Limit -n Torque Mode
- Available in a TQFN-32 (4mmx4mm) Package

APPLICATIONS

- PMSM Motors
- BLDC Motors
- Servo Controllers

All MPS parts are lead-free, halogen-free, and adhere to the RoHS directive. For MPS green status, please visit the MPS website under Quality Assurance. "MPS", the MPS logo, and "Simple, Easy Solutions" are trademarks of Monolithic Power Systems, Inc. or its subsidiaries.

TYPICAL APPLICATION

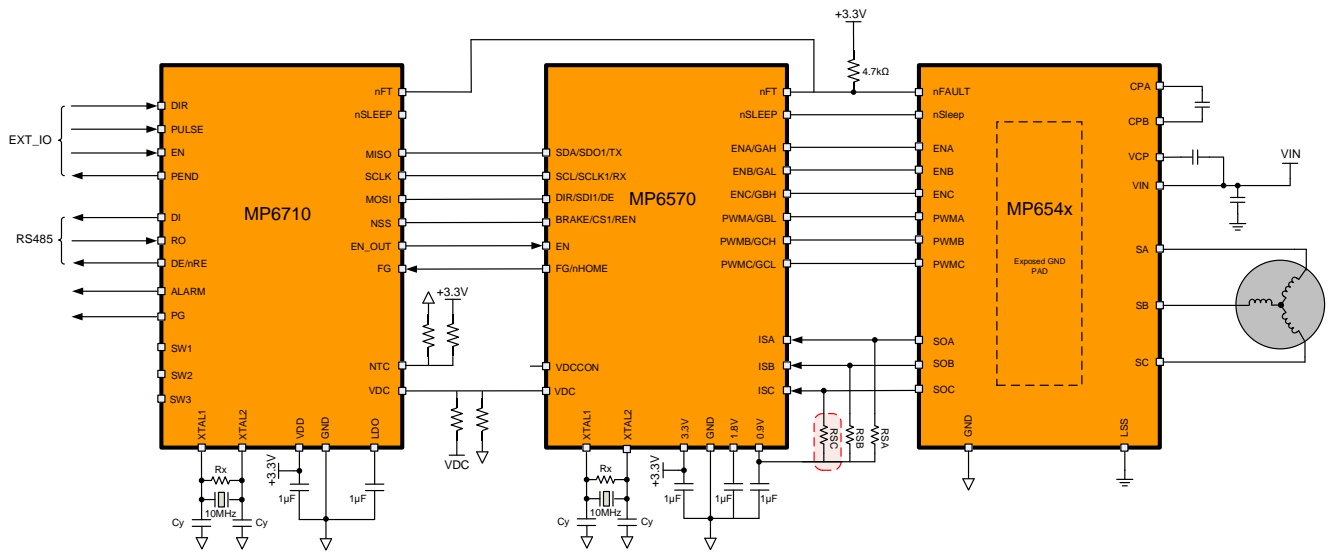

Figure 1: MP6710 + MP6570 + MP654x Solution

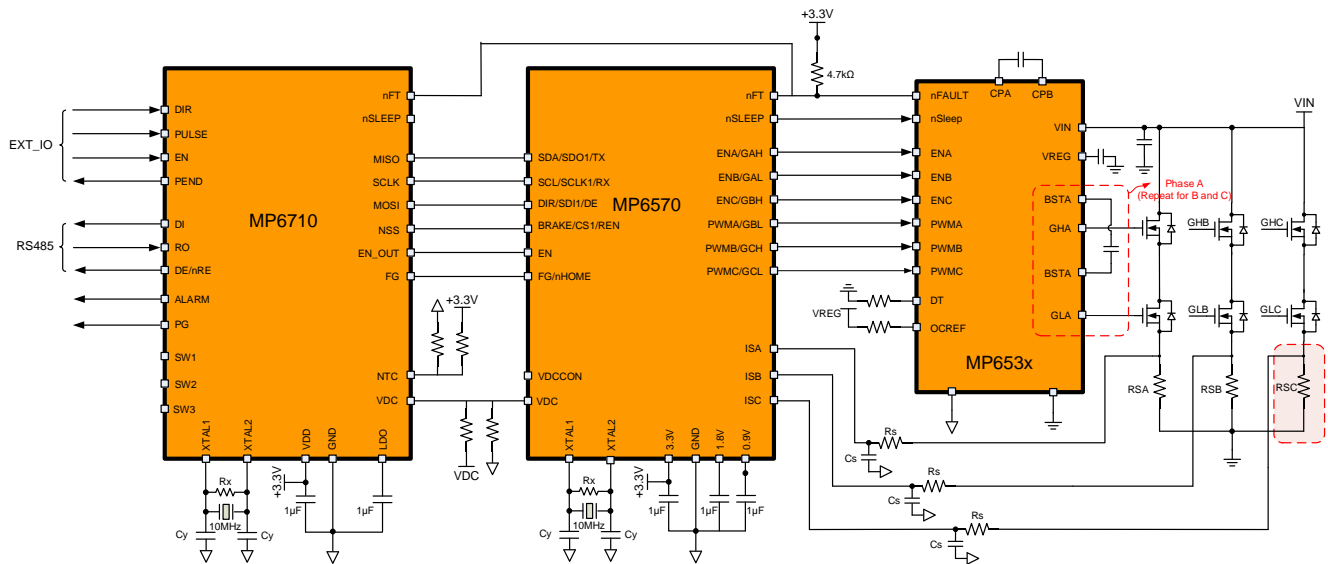

Figure 2: MP6710 + MP6570 + Pre-Driver + MOSFETs Solution

ORDERING INFORMATION

Part Number*	Package	Top Marking	MSL Rating
MP6710GRT-xxxx**	TQFN-32 (4mmx4mm)	<i>See Below</i>	3

* For Tape & Reel, add suffix –Z (e.g. MP6710GRT-xxxx–Z).

** “xxxx” is the register setting option. The factory default is “0000”. For customized options, contact an MPS FAE to obtain a “xxxx” value.

TOP MARKING

MPSYWW

MP6710

LLLLLL

MPS: MPS prefix
 Y: Year code
 WW: Week code
 MP6710: Part number
 LLLLLL: Lot number

PACKAGE REFERENCE

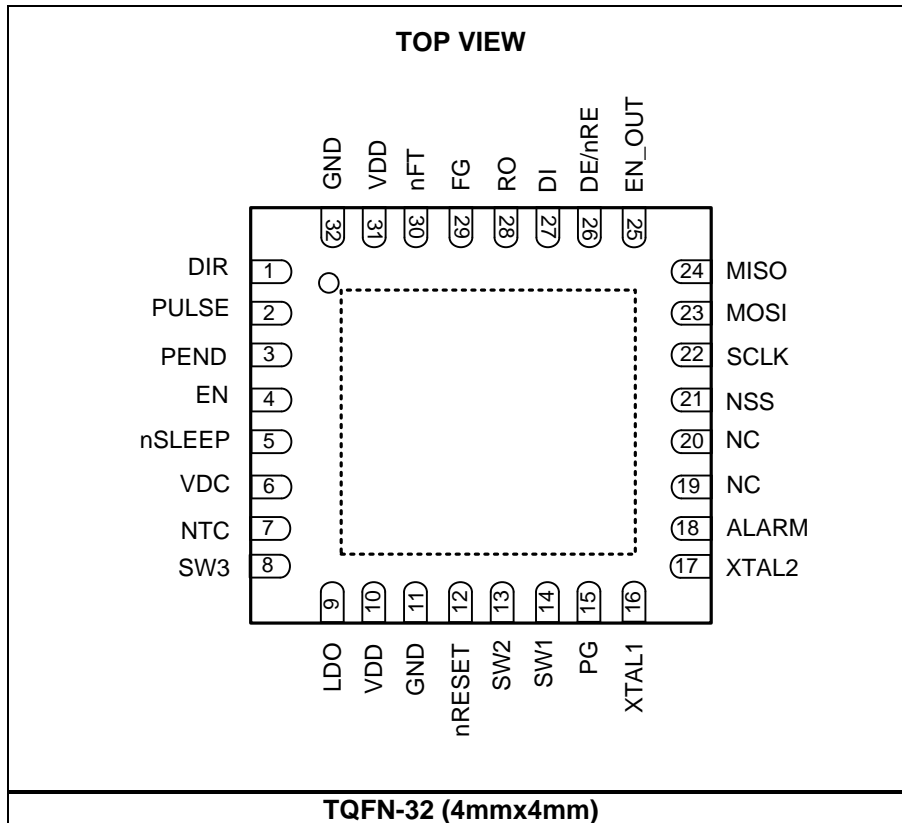

PIN FUNCTIONS

Pin #	Name	Description
1	DIR	Direction selection input: <ul style="list-style-type: none"> • High: clockwise • Low: counterclockwise
2	PULSE	Pulse signal input. Up to 500kHz.
3	PEND	Reach target indication signal output.
4	EN	Enable signal input.
5	nSLEEP	nSLEEP signal output. This pin enables and disables the power stage.
6	VDC	DC input voltage sensing.
7	NTC	PCB temperature-sensing NTC input.
8	SW3	NSTEP setting input 3.
9	LDO	Internal LDO output. Decouple LDO with a 1 μ F to 4.7 μ F ceramic capacitor.
10, 31	VDD	IC power supply input. Bypass VDD with a 1 μ F ceramic capacitor to ground.
11, 32	GND	Ground.
12	nRESET	Analog POR reset for the IC. When the voltage is above the threshold, the MP6710 begins operation. Connect nRESET to VDD through a 4.7k Ω resistor and a 10nF capacitor to ground.
13	SW2	NSTEP setting input 2.
14	SW1	NSTEP setting input 1.
15	PG	Power good output.
16	XTAL1	External crystal oscillator signal input.
17	XTAL2	External crystal oscillator signal output.
18	ALARM	Alarm indication output.
19, 20	NC	No connection.
21	NSS	SPI chip select signal output.
22	SCLK	SPI clock signal output.
23	MOSI	SPI master output slave input.
24	MISO	SPI master input slave output.
25	EN_OUT	Enable signal output.
26	DE/nRE	RS485 DE/nRE signal output.
27	DI	RS485 Tx output signal.
28	RO	RS485 Rx input signal.
29	FG	Rotor position FG input signal.
30	nFT	Fault indication input from power stage and internal fault output.

ABSOLUTE MAXIMUM RATINGS ⁽¹⁾

Supply voltage (V_{DD})	3.6V
All other pins	-0.5V to +3.6V
Continuous power dissipation.... ($T_A = 25^\circ\text{C}$) ⁽²⁾	
TQFN-32 (4mmx4mm).....	2.6W
Junction temperature	150°C
Lead temperature	260°C
Storage temperature.....	-55°C to +150°C

ESD Rating

Human body model (HBM).....	2000V
Charged device model (CDM).....	1000V

Recommended Operating Conditions ⁽³⁾

Supply voltage (V_{DD})	3.3V
Operating junction temp (T_J).....	-40°C to +85°C

Thermal Resistance ⁽⁴⁾	θ_{JA}	θ_{JC}
TQFN-32 (4mmx4mm)	47	4.5 .. °C/W

Notes:

- 1) Exceeding these ratings may damage the device.
- 2) The maximum allowable power dissipation is a function of the maximum junction temperature T_J (MAX), the junction-to-ambient thermal resistance θ_{JA} , and the ambient temperature T_A . The maximum allowable continuous power dissipation at any ambient temperature is calculated by P_D (MAX) = $(T_J$ (MAX) - T_A) / θ_{JA} . Exceeding the maximum allowable power dissipation will cause excessive die temperature, and the regulator will go into thermal shutdown. Internal thermal shutdown circuitry protects the device from permanent damage.
- 3) The device is not guaranteed to function outside of its operation conditions.
- 4) Measured on JESD51-7, 4-layer board.

ELECTRICAL CHARACTERISTICS

VDD = 3.3V, TA = 25°C, EN = high, unless otherwise noted.

Parameters	Symbol	Condition	Min	Typ	Max	Units
Supply Voltage						
VDD operating range	V _{DD}		3	3.3	3.6	V
Quiescent current	I _Q	V _{DD} = 3.3V		12		mA
Power-On Reset (POR)						
POR release threshold	V _{ROT}	V _{DD} rising	1.66	1.79	1.9	V
PUL Input						
PUL input frequency	f _{PUL}				500	kHz
PWM input frequency	f _{PWM}		0.1		10	kHz
Minimum pulse width on PWM	t _{PWM}			1		μs
Logic Input						
Logic high threshold	V _{L_HIGH}		0.6V _{DD}			V
Logic low threshold	V _{L_LOW}				0.3V _{DD}	V
Off-state leakage current	I _{IH}				1	μA
Open-Drain Output						
Low logic output voltage	V _{OL}	2mA load		0.1	0.5	V
High-voltage output voltage	V _{OH}		2.5			V
Output leakage current	I _{OH}	3.3V output			1	μA
Internal Clock Oscillator						
System clock frequency	f _{40M}			40		MHz
ADC and Sample Hold						
Voltage range			0		V _{DD}	V
Resolution ⁽⁵⁾				12		bits
Integral nonlinearity	INL			±2	5	LSB
Sample rate				10		kHz

Note:

5) Guaranteed by characterization data.

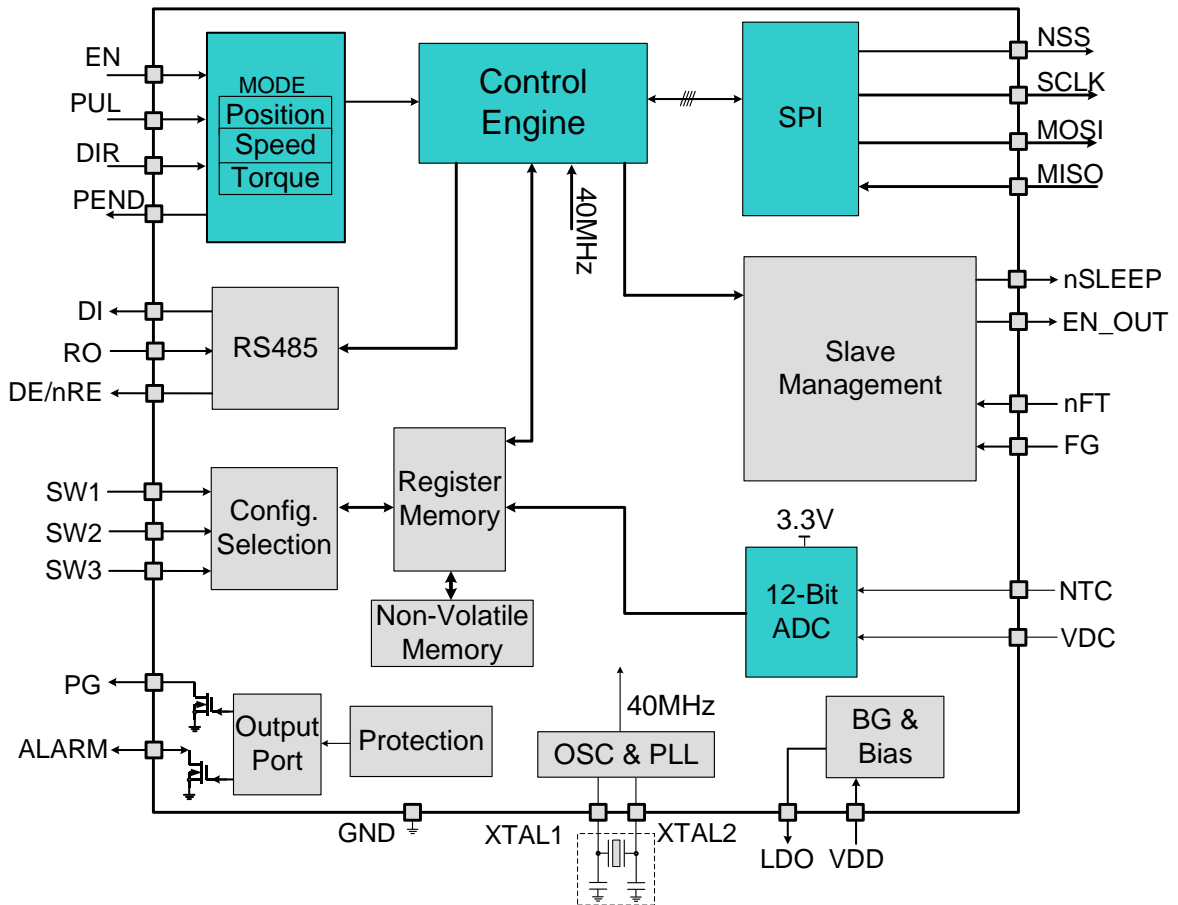
FUNCTIONAL BLOCK DIAGRAM

Figure 3: Functional Block Diagram

OPERATION

The MP6710 is a high-performance motion controller incorporating proportion-integral-differential (PID) algorithms, a curve-planning algorithm, and rich protection functions. It is used for applications with three-phase PMSM and BLDC motors together with the MP6570 to achieve better dynamic response.

The operation of the MP6710 supports three operation modes: speed mode, position mode, and torque mode. The reference command can come from either the digital interface or PULSE/DIR input pins.

A 12-bit ADC is employed for accurate sampling of DC voltage and temperature.

A non-volatile memory is employed in the MP6710 to store parameters programmed through the selectable RS485 digital interface.

Application design is aided by MPS's eMotion System™ Virtual Bench online developer tool.

Robust failure protections include over-current protection, long-time overload protection, rotor-lock protection, over-temperature protection, and over-current protection.

Register Definition

The MP6710 has many operation modes. Almost all the modes can be set by register 34h, including the operation mode, command type, and more.

Address 34h			
Bits	Name	Default	Description
[15:11]	RESERVED	0H	Reserved. Set to default.
[10]	UVLO_EN	0H	UVLO function enable or disable. See the Under-Voltage Lockout (UVLO) section on page 22 for details. 0: Disable UVLO function 1: Enable UVLO function
[9]	FEED_FORWARD	0H	Feed-forward enable or disable. 0: Disable feed-forward function 1: Enable feed-forward function
[8]	SCURVE	0H	S-curve function enable or disable. 0: Disable S-curve function, the position reference profile is the ramp profile 1: Enable S-curve function (see the Position Mode section on page 13 for details)
[7]	NSTEP_TYPE	0H	0: NSTEP determined by register value 1: NSTEP determined by switches
[6]	PWM_MODE	0H	Defines the three-phase bridge PWM driver output mode. 0: Outputs six separate PWM signals to drive the three-phase bridge MOSFETs 1: EN and PWM combination mode, compatible with MPS's MP65xx family of parts
[5]	STANDBY	1H	Standby function in PULSE/DIR mode enable or disable. If standby mode is enabled, the motor starts to run once EN is low and a start command is sent. 0: Standby mode enabled 1: Standby mode disabled

[4]	POS_CMD_TYPE	1H	Selects relative or absolute position mode. 0: Relative position mode 1: Absolute position mode
[3:2]	CMD_MODE	0H	Selects the command type. 00: Digital command 01: Reserved 10: Pulse and direction input 11: PWM and direction input
[1:0]	MODE	0H	Selects the operation mode. 00: Speed mode 01: Position mode 10: Torque mode 11: Reserved

Part and Motor Information

Descriptions

To run the motor, the basic parameters of the motor should be known and stored in the registers of the MP6710. The most important parameters are the motor phase resistance (in mΩ) (MOTOR_R), the rated voltage of the motor

(in V) (MOTOR_V), and the pole pairs (MOTOR_P).

The registers that are not listed in the register definition section from 0x00 to 0x14 can be used to store custom parameters.

Register Definition

Address 00h			
Bits	Name	Default	Description
[15:0]	PART_NUM	6710H	Part number.

Address 01h			
Bits	Name	Default	Description
[15:0]	MOTOR_R	010EH	Motor phase resistor (mΩ).

Address 06h			
Bits	Name	Default	Description
[15:0]	MOTOR_V	0022H	Rated voltage of the motor (V).

Address 08h			
Bits	Name	Default	Description
[15:0]	MOTOR_P	0004H	Motor pole pairs.

Address 14h			
Bits	Name	Default	Description
[15:0]	PART_VER	1900H	Part version identifier.

RS485 Communication

The RS485 communication port can be used to set configuration parameters and send commands during operation.

The frame format should be 1 start bit, 8 data bits, 1 odd parity check bit, and 1 stop bit, with the least significant bit (LSB) sent first.

Write Register Operation

To write data to the MP6710, a data packet is sent that contains a slave address, register

address, and data (see Figure 4). The 1 sent at the beginning of the register address byte indicates a write operation.

Read Register Operation

To read data from the MP6710, the slave address and register address are sent, and then the MP6710 returns the data (see Figure 5). The 0 sent at the beginning of the register address byte indicates a read operation.

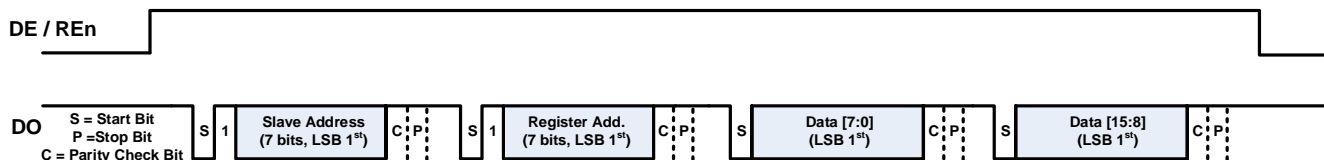

Figure 4: MP6710 Write Register Protocol

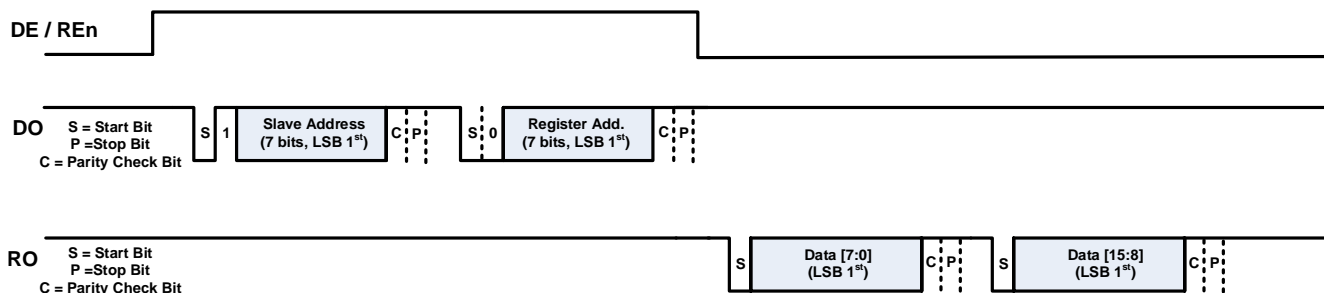

Figure 5: MP6710 Read Register Protocol

Register Definition

Address 5Ch			
Bits	Name	Default	Description
[16:7]	RESERVED	0H	Reserved. Set to default.
[6:0]	RS485_ADDR	00H	RS485 slave address.

Address 5Dh			
Bits	Name	Default	Description
[15:0]	RS485_BAUD RATE	0E10H	RS485 baud rate setting. Baud rate = RS485_BAUD_RATE x 32. To set the baud rate to 115,200bps, RS485_BAUD_RATE should be 115,200 / 32 = 3600.

Operation Mode

The MP6710 supports three operation modes: torque mode, speed mode, and position mode. For each operation mode, the reference command can come from either the RS485 interface or the PULSE/DIR input pins.

Torque Mode

Torque mode enables the motor to output a specified mechanical torque. The MP6710 supports torque commands from the communication interface or the PULSE/DIR pins. In torque mode, the maximum speed limit is programmable through the T_MAX_SPD and ANTI_TORQUE_GAIN registers. The loop parameters are optimized through the CURRENT_KP and CURRENT_KI registers (see the Loop Parameters section on page 17 for details).

RS-485 Control Mode

In torque control mode, the torque command (which corresponds to quadrature axis current) is set directly through the IQ_CMD (0x2F) register.

If I_Q is positive, then $IQ_CMD[11:0] = I_Q \times 1.5 \times K_{AD} \times 1024 / 1.6$.

If I_Q is negative, then $IQ_CMD[11:0] = 2^{12} - (I_Q \times 1.5 \times K_{AD} \times 1024 / 1.6)$.

Where I_Q is the torque current in A, and has the same value as the motor phase peak current; and K_{AD} is the current-sense gain coefficient.

Register Definition

Address 2Dh			
Bits	Name	Default	Description
[15:0]	T_MAX_SPD	0064H	Speed limit at torque mode (LSB/100µs). 1LSB/100µs = 9.155rpm.

Address 2Eh			
Bits	Name	Default	Description
[15:0]	ANTI_TORQUE_GAIN	000AH	Anti-torque gain of speed limit in torque mode.

Address 2Fh			
Bits	Name	Default	Description
[15:12]	RESERVED	0H	Reserved. Set to default.

If using an MP654x series power stage, then $K_{AD} = R_{PULL} \times K_{CS}$, where R_{PULL} is the pull-up resistor value (in Ω), and K_{CS} is the current-sense ratio of the MP654x power stage.

If using a MP653x or MP192x series power stage, $K_{AD} = R_{CS} \times AD_GAIN$, where R_{CS} is the current-sense resistance (in Ω), and AD_GAIN is the amplifier gain setting described in the Hardware Settings section on page 24.

PWM/DIR Mode

In PWM/DIR command control mode, the motor torque is controlled by the duty cycle of the PWM input. The real motor torque is IQ_CMD multiplied by $DUTY_CYCLE$, and IQ_CMD is programmable (register 0x2F). The PWM signal frequency should be between 100Hz and 10kHz to achieve better adjustment resolution. The DIR pin can control the torque direction. When DIR is high, the torque is positive, which means the motor tries to go clockwise.

Torque Mode Speed Limit

Because the motor speed is not controlled in torque mode, to avoid the motor running too fast, the torque mode speed limit function should be used.

If the motor speed is below the speed limit setting, the output torque is the same as the IQ_CMD setting. If the motor speed is above the speed limit setting, the output torque (IQ_OUT) is $IQ_CMD - ANTI_TORQUE_GAIN \times (SPEED - T_MAX_SPD)$.

[11:0]	IQ_CMD	000AH	<p>I_Q reference, which is proportional to the motor's output torque.</p> <p>When I_Q is positive: $IQ_CMD[11:0] = I_Q \times 1.5 \times K_{AD} \times 1024 / 1.6$</p> <p>When I_Q is negative: $IQ_CMD[11:0] = 2^{12} - I_Q \times 1.5 \times K_{AD} \times 1024 / 1.6$</p>
--------	--------	-------	---

Speed Mode

In speed mode, the velocity ramp-up/ramp-down slope is programmable with the SPD_CMD_SLOPE register.

The loop parameters can be optimized through registers KP_SPD, KP_GAIN_SPD, KI_SPD, KI_GAIN_SPD, and KC_SPD, based on the real mechanical load and desired loop response.

After sending the speed command, 0x0000 should be written to register 0x76 to update the speed command.

RS-485 Control Mode

If the speed command is set through the RS-485 interface, then it is set using the SPD_CMD register (0x4D and 0x4E), described below:

Clockwise:

$$SPD_CMD[31:0] = (\text{speed} / 60) \times 2^{32} / 10,000$$

$$0x4D = SPD_CMD[31:16]$$

$$0x4E = SPD_CMD[15:0]$$

Counterclockwise:

$$SPD_CMD[31:0] = 2^{32} - (\text{speed} / 60) \times 2^{32} / 10,000$$

$$0x4D = SPD_CMD[31:16]$$

$$0x4E = SPD_CMD[15:0]$$

Where speed is the target speed (in rpm).

PWM/DIR Control Mode

In PWM/DIR command control mode, the motor speed is controlled by the duty cycle of the PWM input. The real motor speed is SPD_CMD multiplied by DUTY_CYCLE, and SPD_CMD is programmable (registers 0x4D and 0x4E). The PWM signal frequency should be between 100Hz and 10kHz to achieve better resolution.

The DIR pin can control the direction. When DIR is at a high level, the motor tries to move clockwise.

Speed Mode Slope Setting

The MP6710 speed reference uses a linear ramp profile (trapezoidal profile) (see Figure 6).

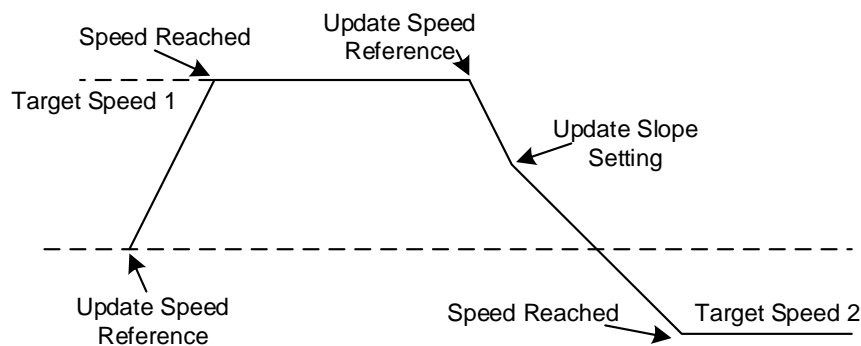

Figure 6: Speed Reference Profile

After updating the speed reference, the motor speed ramps to the target speed using the set slope rate. If the slope rate setting is changed during ramping, the actual slope rate changes immediately, and the motor changes speed according to the newly set ramp slope.

SPD_CMD_SLOPE is calculated using Equation (1):

$$SPD_CMD_SLOPE = \text{slope} \times 2^{32} \times 10^{-5} / 60 \quad (1)$$

Where slope is the speed ramping slope (in rpm/ms).

Register Definition

Address 4Dh			
Bits	Name	Default	Description
[15:0]	SPD_CMD [31:16]	000AH	Speed reference high (16 bits).

Address 4Eh			
Bits	Name	Default	Description
[15:0]	SPD_CMD [15:0]	0000H	Speed reference low (16 bits).

Address 4Fh			
Bits	Name	Default	Description
[15:0]	SPD_CMD_ SLOPE	1300H	Speed reference slope (LSB/100µs/100µs). The relationship between the register value and the real slope is calculated with the following equation: $\text{SPD_CMD_SLOPE} = \text{slope} \times 2^{32} \times 10^{-5} / 60$ Where slope is the speed ramping slope (in rpm/ms).

Position Mode

To smoothly ramp the motor speed, the velocity up/down slope is programmable via the POS_CMD_SLOPE register.

The loop parameters can be optimized via the KP_POS and KP_GAIN_POS registers, according to the system requirements with the real mechanical load.

The maximum torque limit is programmable via the MAX_LIMIT_IQ register.

After sending the position command, 0x0000 should be written to register 0x76 to update the position command.

RS-485 Control Mode

Using RS-485 control, the position mode is programmable in absolute command mode or incremental command mode. The mode is set through the POS_CMD_TYPE register (0x34h). Absolute command mode moves the motor to an absolute position; incremental command mode moves the motor relative to its present position.

In absolute command mode, the maximum command limit is ±32,767 mechanical revolutions.

The command is set via POS_CMD (registers 0x4A and 0x4B), as described below:

Clockwise:

$$\text{POS_CMD}[31:0] = (\text{revs} + \theta / 360) \times 2^{16}$$

$$0x4A[15:0] = \text{POS_CMD}[31:16]$$

$$0x4B[15:0] = \text{POS_CMD}[15:0]$$

Counterclockwise:

$$\text{POS_CMD}[31:0] = 2^{32} - (\text{revs} + \theta / 360) \times 2^{16}$$

$$0x4A[15:0] = \text{POS_CMD}[31:16]$$

$$0x4B[15:0] = \text{POS_CMD}[15:0]$$

Where revs is the target position command (in number of full revolutions), and θ is the target position command angle.

PUL/DIR Control Mode

In PUL/DIR command control mode, the motor works in incremental position mode. Each rising edge on the PUL input moves the motor by a programmable increment. The number of pulses per revolution is programmable to be 512, 1024, 2048, or 4096 pulses per mechanical revolution. This is set through the NSTEP register or the SW1, SW2, and SW3 pins. The default value is 4096.

Position Mode Slope Setting

In position mode, after a new position command is given, the reference generation block inside the MP6710 calculates the position curve every 100µs to make the motion smooth (see Figure 7).

When the speed limit is not reached and there is enough angle left for the motor to decrease the speed and stop, the motor increases the speed or maintains its speed. When the speed reaches the speed limit, the motor limits the speed at the set value. When the reference generation block detects that the remaining angle is not enough for the motor to ramp down the speed using the set speed slope, it slows the motor, so that once the position is reached, the speed is zero.

If a new position command is given when the motor speed is ramping down, the reference generation block increases the motor speed again to make the motor reach the target position as soon as possible.

The position mode slope is set via the ACCE and POS_CMD_SLOPE registers.

ACCE sets the speed ramp slope in position mode. The ACCE value range can be 1 to 31; the larger the ACCE is, the larger the speed slope will be.

POS_CMD_SLOPE sets the position ramp slope, which is the same as the speed limit.

The relationship between the real speed limit (in rpm) and the POS_CMD_SLOPE register value is $POS_CMD_SLOPE = rpm \times 2^{16} / 60 / 10,000$.

Position Bias Setting

To make it possible to set the mechanical zero position, POS_BIAS can be set (registers 0x4A and 0x4B).

After finding the mechanical zero position, the POSITION (registers 0x5F and 0x60) can be read back and written to POS_BIAS, so the MP6710 treats that position as the zero position. POS_CMD is then relative to that position.

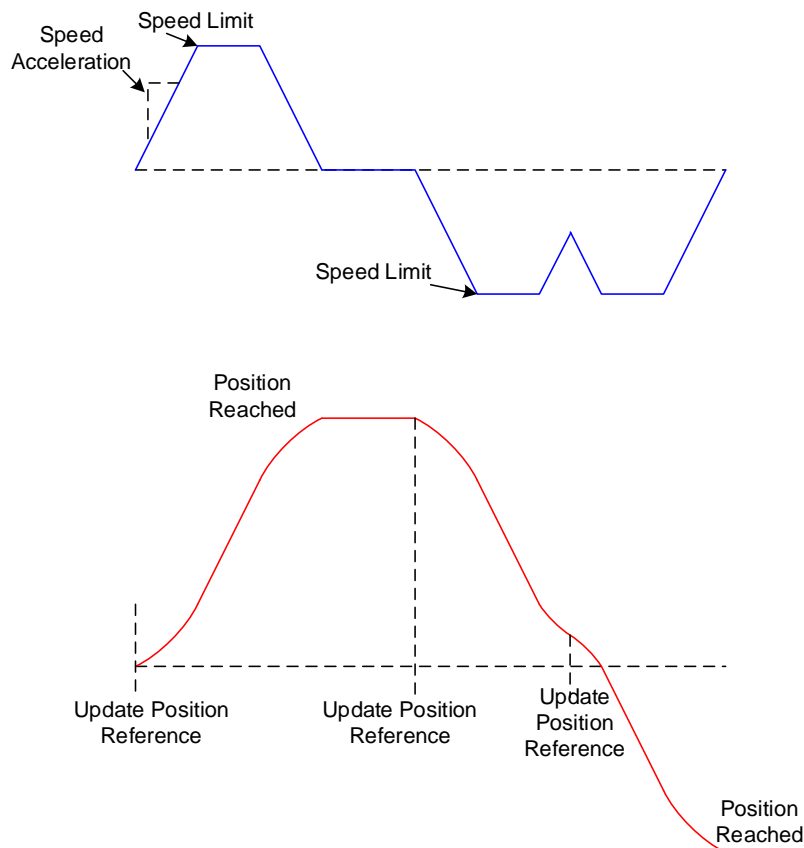

Figure 7: Position Reference Profile

Register Definition

Address 1Dh			
Bits	Name	Default	Description
[15:5]	RESERVED	0H	Reserved. Set to default.
[4:0]	ACCE	1H	S-curve acceleration setting. The value range is 1 to 31. When ACCE = 1, the acceleration rate is 11444rpm/s.

Address 48h			
Bits	Name	Default	Description
[15:0]	POS_BIAS [31:16]	0x0000	Position bias rounds.

Address 49h			
Bits	Name	Default	Description
[15:0]	POS_BIAS [15:0]	0x0000	Position bias angle (LSB).

Address 4Ah			
Bits	Name	Default	Description
[15:0]	POS_CMD [31:16]	0000H	Position reference rounds.

Address 4Bh			
Bits	Name	Default	Description
[15:0]	POS_CMD [15:0]	0000H	Position reference angle (LSB).

Address 4Ch			
Bits	Name	Default	Description
[15:0]	POS_CMD_ SLOPE	0064H	Position reference slope (LSB/100µs). POS_CMD_SLOPE = rpm x 2 ¹⁶ / 60 / 10,000

Address 50h			
Bits	Name	Default	Description
[15:0]	NSTEP	0004H	NSTEP in pulse input mode. Pulses per revolution is 65,536 / 2 ^{NSTEP} . If NSTEP is set by the SW1, SW2, and SW3 pins, then the relationship between NSTEP and the SWx pin level is calculated with the following equation: $\text{NSTEP} = (\text{SW3} \times 4 + \text{SW2} \times 2 + \text{SW1}) + 4$

Loop Parameters

The MP6710 use a three-loop control method. To achieve a more compact design, the current loop is implemented inside the MP6570, and the speed loop and position loop is in the MP6710 (see Figure 8).

MPS provides an easy-to-use GUI to help engineers design and tune better loop parameters. Download the eMotion System™ Virtual Bench from the MPS website: www.monolithicpower.com.

To make it easier to tune, the loop parameters are simplified to the loop bandwidth. After setting the motor and load parameters, start in torque mode and select the bandwidth to be about 600Hz to 1000Hz; select the speed loop bandwidth to be about 100Hz to 200Hz; select the speed loop zero to be between 2Hz and 10Hz; and select the position loop bandwidth to be about 10Hz to 30Hz.

This is a good start to get the motor running. To achieve better dynamic response, the speed and position loop should be higher, though higher bandwidth causes more vibration and noise, so the appropriate tradeoff must be chosen between dynamic response and noise.

Current Loop

The current loop is the most internal loop. The MP6710 uses $I_D = 0$ control, which controls the direct-axis current to 0, so that the output torque is almost proportional to the quadrature axis current (I_Q).

Speed Loop

The speed loop is used to control the motor speed. The input is the speed command, and the output is I_Q referenced to the current loop. The speed loop uses PI control.

I_{Q_LIMIT} (in A) of the speed loop limits the maximum output phase peak current, which limits the maximum output torque.

Position Loop

The position loop is the outermost loop, and is used to control the motor position. The input is the position command, and the output is speed referenced to the speed loop. The position loop uses P control to avoid overshoot. Feed-forward functionality can be enabled if a low following error is needed.

SPD_LIMIT of the position loop limits the maximum motor speed in position mode.

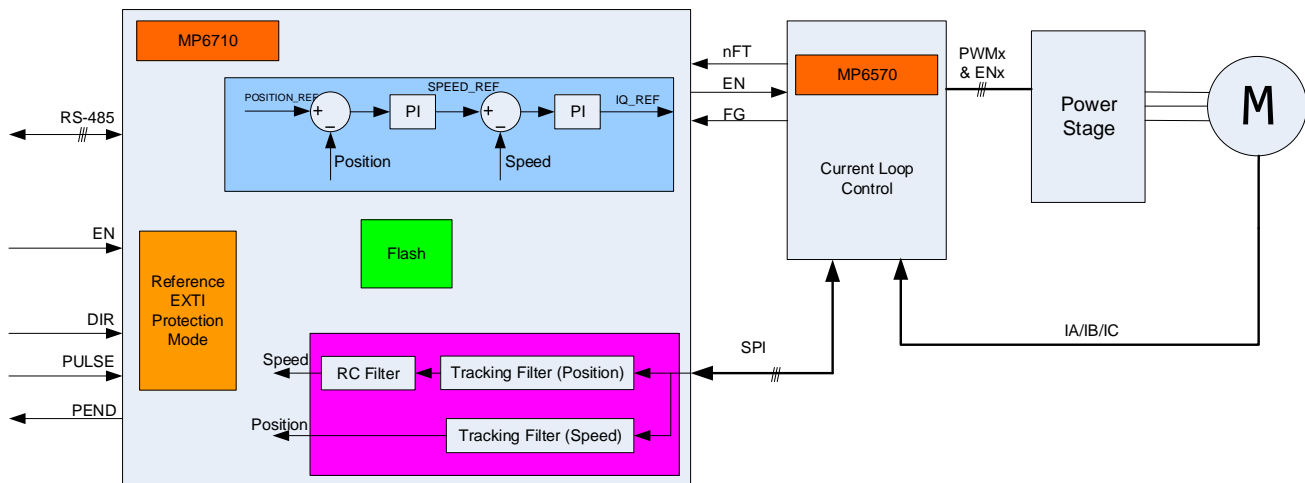

Figure 8: Control Loop Block Diagram

Register Definition

Address 2Bh			
Bits	Name	Default	Description
[15:0]	KP_CURRENT	3BB5H	Current loop proportional gain.

Address 2Ch			
Bits	Name	Default	Description
[15:0]	KI_CURRENT	2BA6H	Current loop integral gain.

Address 22h			
Bits	Name	Default	Description
[15:0]	KP_SPD	FDE8H	Speed loop proportional gain.

Address 23h			
Bits	Name	Default	Description
[15:0]	KP_SPD_GAIN	8009H	Gain ratio of the speed loop proportional gain.

Address 24h			
Bits	Name	Default	Description
[15:0]	KI_SPD	0309H	Speed loop integral gain.

Address 25h			
Bits	Name	Default	Description
[15:0]	KI_SPD_GAIN	8013H	Gain ratio of speed loop integral gain.

Address 26h			
Bits	Name	Default	Description
[15:0]	KC_SPD	0032H	Speed loop anti-integral gain.

Address 27h			
Bits	Name	Default	Description
[15:0]	MAX_LIMIT_IQ	03FFH	Maximum I _q limit of the speed loop output. $MAX_LIMIT_IQ = I_{Q_LIMIT} \times 1.5 \times K_{AD} \times 1024 / 1.6$

Address 1Ah			
Bits	Name	Default	Description
[15:0]	KP_POS	00FAH	Position loop proportional gain.

Address 1Bh			
Bits	Name	Default	Description
[15:0]	KP_POS_GAIN	8008H	Gain ratio of the position loop proportional gain.

Address 1Ch			
Bits	Name	Default	Description
[15:0]	SPD_LIMIT	02FFH	Output limit of the position loop (LSB/100µs). 1LSB/100µs = 9.155rpm.

Filters

To filter out the noise of the position and speed feedback signals, low-pass and tracking filters are added.

The filter bandwidth is calculated automatically by the eMotion System™ Virtual Bench program.

Register Definition

Address 40h			
Bits	Name	Default	Description
[15:0]	TRACK_POS_ALPHA	1999H	Alpha of position tracking filter.

Address 41h			
Bits	Name	Default	Description
[15:0]	TRACK_POS_BETA	0007H	Beta of position tracking filter.

Address 42h			
Bits	Name	Default	Description
[15:0]	TRACK_SPD_ALPHA	03333H	Alpha of speed tracking filter.

Address 43h			
Bits	Name	Default	Description
[15:0]	TRACK_SPD_BETA	000DH	Beta of speed tracking filter.

Address 44h			
Bits	Name	Default	Description
[15:0]	RC_SPD_ALPHA	3333H	Alpha of speed RC filter.

INL Calibration

To improve the intrinsic nonlinearity (INL) of the angle sensor, the MP6570 embeds an AccuFilter function with 32 data points, which is stored in the NVM for calibration.

INL Calibration Principle

To get the angle error, a reference must be known. The reference can be the position information of the optical encoder or other low-

INL position sensors. Another way to get the reference is to let the motor run at a constant speed with a large inertia on the shaft so that the speed is stable in one turn. Then the MP6710 samples the sensor angle with accurate timing (see Figure 9).

It is recommended to perform INL calibration using the eMotion System™ Virtual Bench program.

Use the MP6710 to implement the calibration sequence by following the steps below:

1. Run the motor run at a steady speed and sample the sensor data. The high-accuracy timing signal is taken as a reference, assuming that the motor speed is constant in one revolution (see Figure 9). To provide a stable speed, it is necessary to run the motor with a high speed and a large inertial load; 5 to 8 times the motor inertia is a good choice.
2. Save the error data reference minus the sensor data to the 32 data points in the MP6570, and store them in the NVM of the MP6570.

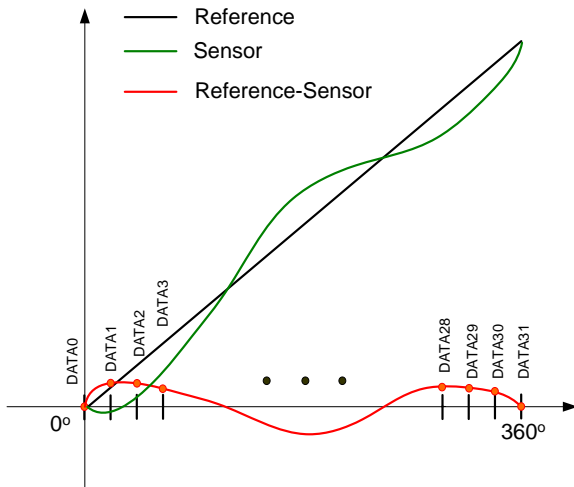
Figure 9: Sensor Error Calibration

Find Theta Bias

Find Theta Bias Principles

To detect the rotor position, attach a magnet at the shaft of the motor (see Figure 10). The magnetic angular sensor embedded in the MP6570 works as an absolute rotor position

sensor. In the FOC algorithm, the electrical angle must be used for Park and inverse Park

Register Definition

Address 3Eh			
Bits	Name	Default	Description
[15:0]	I_HOLD	08C4H	Hold current when the rotor is aligning (mA).

Address 3Fh			
Bits	Name	Default	Description
[15:0]	T_HOLD	03E8H	Hold time when the rotor is aligning (ms).

transformations. The sensor only detects the magnetic field angle of the magnet attached to the motor shaft; therefore, the sensor position bias angle when the rotor is aligning with Phase A must be determined first.

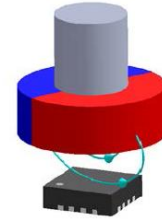
Figure 10: How to Sense the Rotor Position

Use the MP6710 to implement the find theta bias sequence by following the steps below:

1. Apply a current to terminals U and V to generate torque and drag the shaft to position 1, then read the sensor data 1.
2. Apply a current to terminals U and W to generate torque and drag the shaft to position 2, then read the sensor data 2.
3. Calculate THETA_BIAS and THETA_DIR from data 1 and data 2.
4. Write THETA_BIAS and THETA_DIR to the MP6570 register, and store them in the NVM.

For more details, refer to Application Note AN131: How to Set the Sensor Position Bias Angle.

The eMotion System™ Virtual Bench provide an auto-theta-bias function. After setting I_HOLD and T_HOLD, send the find theta bias command; then the MP6710 does the steps described above automatically.

Address 67h			
Bits	Name	Default	Description
[15:0]	THETA_BIAS	0000H	Theta bias between the rotor and magnet.

Address 68h			
Bits	Name	Default	Description
[15:1]	RESERVED	0000H	Reserved. Set to default.
[0]	THETA_DIR	0000H	Theta DIR or the sensor. 0: The IC uses the original data value from the angular sensor 1: The IC uses the complementary data value from the angular sensor

Load to Flash

To store the parameters in the flash memory, send a load to flash command (send 0x0002 to register 0x73) to the MP6710.

Load to flash is only possible when the motor is stopped.

Reach Target Indication

The reach target indication function is useful when the user wants to know whether the last command was processed correctly by the motor.

Register Definition

Address 1Eh			
Bits	Name	Default	Description
[15:0]	POS_IN_RANGE	0024H	Position reach target threshold (LSB). 1LSB = 360 / 65536°.

Address 29h			
Bits	Name	Default	Description
[15:0]	SPD_IN_RANGE	0006H	Speed reach target threshold (LSB/100µs). 1LSB/100µs = 9.155rpm.

Address 69h			
Bits	Name	Default	Description
[15:2]	RESERVED	0H	Reserved. Set to default.
[1]	SPD_REACH	0H	Motor reach target speed. Active only in speed mode.
[0]	POS_REACH	0H	Motor reach target position. Active only in position mode.

Brake Mode

The MP6710 has an energy-recycle brake function. After the brake command is sent, the MP6710 controls the motor to generate a reverse torque that slows down the motor.

When the motor speed is lower than BRAKE_STOP_SPEED, no additional reverse torque is generated. The brake torque current and BRAKE_STOP_SPEED can be set.

If energy recycle is not allowed, set BRAKE_IQ to zero. Under this setting, when braking, the

motor does not generate reverse torque and the motor stops due to mechanical friction.

Register Definition

Address 37h			
Bits	Name	Default	Description
[15:11]	RESERVED	0H	Reserved. Set to default.
[10:0]	BRAKE_IQ	0000H	The reverse I _Q current in energy-recycle brake mode. BRAKE_IQ[11:0] = I _{Q_BRAKE} X 3 / 2 X AD_GAIN x 1024 / 1.6

Address 38h			
Bits	Name	Default	Description
[15:0]	BRAKE_STOP_SPEED	0x0000	Defines the minimum speed threshold in energy-recycle brake mode. When the motor speed is below this speed threshold, the IC exits energy-recycle brake mode and switches to coasting brake mode with all MOSFETs off (LSB/100µs). 1LSB/100µs = 9.155rpm.

Protections

The MP6710 has rich protection functions to avoid unexpected failure modes and external component damage. The fault type can be determined either from the value of register 0x53 or from the ALARM pin signal (see Table 1).

Power Stage Fault Protection

If the power stage fault signal is connected to the MP6570's nFT pin, the MP6710 can detect the power stage fault.

If the fault is detected, the MP6710 shuts down the power stage to avoid further damage to the system.

Under-Voltage Lockout (UVLO) Protection

If UVLO protection is enabled, when the DC bus voltage is below V_{UVLO} (register 5Bh), the UVLO bit in register 53h will be set. The user can decide what to do in this condition.

UVLO protection can be disabled by setting UVLO_EN to 0.

Rotor-Lock Protection

In speed mode, if the speed command is greater than 20rpm and the angle that the motor shaft turns in a time window is less than 5°, rotor-lock protection is triggered.

In position mode, if the target position is not reached and the angle that the motor shaft turns in a time window is less than 5°, rotor-lock protection is triggered.

This protection can be disabled by setting the LOCK_EN to 0. The time window can be set. See register 0x55 for details.

Over-Current Protection (OCP)

OCP usually occurs when the components on the board are damaged or a short circuit occurs. The MP6710 shuts down the power stage to avoid further damage to the system.

The OCP threshold can be set via register 5Ah.

Overload Protection

To avoid damaging the mechanical system and the motor, overload protection is triggered when the output torque exceeds 75% of IQ_LIMIT and lasts for a set time window. The MP6710 shuts down the power stage so that electrical power is not delivered to the motor or mechanical system.

Overload protection can be disabled by setting OVERLOAD_EN to 0, and the time window can be set. See register 55h for details.

Over-Temperature Protection

If there is an NTC that can sense the temperature (and it is connected to the MP6710's NTC pin), over-temperature protection can be achieved.

Temperature sensing is optimized when using the MURATA NCU15XH103F60RC NTC. If using another NTC, the real temperature should be calibrated separately to obtain the accurate temperature. When the sensing temperature exceeds the set value, over-temperature protection is triggered. The MP6710 does not shut down the power stage when over-temperature protection is triggered. It sends a fault signal, and lets the user decide what to do in this condition.

Clear Error

To clear the error and restart the motor from a fault state without powering off the motor, send the Clear Error command (send 0x0000 to register 0x72).

Table 1: Fault Time Indication

Fault Type	Register 0x53 Flag Bit	ALARM Pin Toggle Times
OCP	Bit 2	3
Rotor lock	Bit 3	4
Overload	Bit 4	5
Over-temperature	Bit 5	6

Register Definition

Address 53h			
Bits	Name	Default	Description
[15:7]	RESERVED	0H	Reserved. Set to default.
[6]	UVLO	0H	Under-voltage status.
[5]	OTP	0H	Over-temperature status flag.
[4]	OVERLOAD	0H	Overload protection triggered flag.
[3]	LOCK	0H	Lock protection triggered flag.
[2]	OCP	0H	Over-current protection triggered flag.
[1]	PSFT	0H	Power stage fault protection triggered flag.
[0]	MEMORY	0H	MP6570 memory fault status.

Address 54h			
Bits	Name	Default	Description
[15:5]	RESERVED	0H	Reserved. Set to default.
[4]	RETRY_EN[4]	0H	Fault retry function enable or disable. 0: Disabled. Fault protections are in latch-off mode 1: Enabled. Fault protections are in retry mode
[3:0]	FAULT_ RETRY_ TIME [3:0]	2H	Fault retry time setting. Retry time = (FAULT_RETRY_TIME + 1) x 0.5s

Address 55h			
Bits	Name	Default	Description
[15:13]	RESERVED	0H	Reserved. Set to default.
[12]	OVERLOAD_EN	0H	Overload protection function enable or disable. 0: Disabled 1: Enabled
[11:8]	OVERLOAD_TIME	0H	Overload detection time setting. Detection time = (OVERLOAD_TIME + 1) x 1s
[7:5]	RESERVED	0H	Reserved. Set to default.
[4]	LOCK_EN	0H	Lock protection function enable or disable. 0: Disabled 1: Enabled
[3:0]	LOCK_TIME	0H	Lock detection time setting. Detection time = (LOCK_TIME + 1) x 0.5s

Address 56h			
Bits	Name	Default	Description
[15:1]	VDC_LIMIT	0000H	VDC limit voltage. $VDC_LIMIT[15:1] = V_{IN_LIMIT} / 1.6 \times K_{VIN} \times 256$ Where K_{VIN} is the resistor-divider ratio, calculated with $R_L / (R_L + R_H)$.
[0]	VDC_LIMIT_EN	0000H	VDC limit function enable bit. 0: Disabled 1: Enabled

Address 5Ah			
Bits	Name	Default	Description
[15:10]	RESERVED	0H	Reserved. Set to default.
[9:0]	IOCP	03FFH	OCP protection threshold. The protection threshold current is $IOCP[9:0] \times AD_GAIN \times 1024 / 1.6$.

Address 5Bh			
Bits	Name	Default	Description
[15:0]	V_UVLO	0000H	UVLO voltage threshold. $UVLO[15:0] = V_{UVLO} / 3.3 \times K_{VIN} \times 4096$ Where K_{VIN} is the resistor-divider ratio, calculated with $R_L / (R_L + R_H)$.

Address 6Bh			
Bits	Name	Default	Description
[15:0]	OTP_SET	0055H	Over-temperature indication threshold.

Hardware Settings

Switching Frequency

A higher switching frequency leads to a smaller current ripple, but higher switching loss on the MOSFETs. Select the appropriate tradeoff for the design. For most applications, a 20kHz to 40kHz frequency is a good choice.

Dead Time

To avoid shoot-through on the three-phase bridge, insert a dead time between the turn-on and turn-off signals of the MOSFETs for the same half-bridge. The dead time should be determined according to the specifications of the MOSFET and the pre-driver.

AD Gain

If using current-sense resistors as current feedback, AD_GAIN can be set to achieve better current-sense accuracy.

The reference for current-sensing ADC is 1.6V, and the bias voltage is 0.9V. To achieve the best accuracy, first determine the maximum phase current (I_{PEAK}). The AD_GAIN selection should follow $0 < 0.9 + I_{PEAK} \times R_{CS} \times AD_GAIN < 1.6$.

Therefore, if $AD_GAIN < 0.7 / I_{PEAK} / R_{CS}$, choose the largest AD_GAIN from the possible values. See register 59h for details.

Register Definition

Address 57h			
Bits	Name	Default	Description
[15:0]	FSW	0014H	Switching frequency (kHz).

Address 58h			
Bits	Name	Default	Description
[15:0]	DEAD_TIME	0020H	Dead time of the half-bridge switching signal. DEAD_TIME x 12.5ns.

Address 59h			
Bits	Name	Default	Description
[15:4]	RESERVED	0H	Reserved. Set to default.
[3]	AD_MODE	0H	Defines the AD sample mode. 0: Voltage signal input mode for ADC sample 1: Current signal input mode for ADC sample
[2:0]	AD_GAIN	7H	Defines the AD gain setting in voltage-signal input mode. 000: $K_{AD} = 12X$ 001: $K_{AD} = 8X$ 010: $K_{AD} = 7X$ 011: $K_{AD} = 6X$ 100: $K_{AD} = 5X$ 101: $K_{AD} = 4X$ 110: $K_{AD} = 3X$ 111: $K_{AD} = 2X$

Read-Only Registers

Description

The MP6710 has some read-only registers for position, speed, and other information readback.

For the relationship between the register value and the real physical value, see the Register Definition section on page 26.

Register Definition

Address 5Eh			
Bits	Name	Default	Description
[15:0]	TEMPER- ATURE	0H	PCB temperature. Temperature-sensing is optimized when using the MURATA NCU15XH103F60RC NTC. If using another NTC, the real temperature should be calibrated separately to get the accurate temperature.

Address 5Fh			
Bits	Name	Default	Description
[15:0]	POSITION [31:16]	0000H	Theta angle of the motor shaft rounds.

Address 60h			
Bits	Name	Default	Description
[15:0]	POSITION [15:0]	0000H	Theta angle of the motor shaft angle (LSB). 1LSB = 360 / 65536°

Address 61h			
Bits	Name	Default	Description
[15:0]	SPEED[15:0]	0000H	Speed feedback low (16 bits). The negative value is represented by a complement code. SPEED [31:0] = (rpm / 60) x 2 ³² / 10,000

Address 62h			
Bits	Name	Default	Description
[15:0]	SPEED[31:16]	0000H	Speed feedback high (16 bits).

Address 63h			
Bits	Name	Default	Description
[15:12]	RESERVED	0H	Reserved. Set to default.
[11:0]	IQ_LATCH	0000H	I _q feedback. The negative value is represented by a complement code. IQ_LATCH[11:0] = I _q x 1.5 x K _{AD} x 1024 / 1.6

Address 64h			
Bits	Name	Default	Description
[15:12]	RESERVED	0H	Reserved. Set to default.
[11:0]	ID_LATCH	0000H	I _d feedback. The negative value is represented by a complement code. ID_LATCH[11:0] = I _d x 1.5 x K _{AD} x 1024 / 1.6

Address 65h			
-------------	--	--	--

Bits	Name	Default	Description
[15:12]	RESERVED	0H	Reserved. Set to default.
[11:0]	UQ_LATCH	0000H	Quadrature axis voltage.

Address 66h			
Bits	Name	Default	Description
[15:12]	RESERVED	0H	Reserved. Set to default.
[11:0]	UD_LATCH	0000H	Direct axis voltage.

Address 6Ah			
Bits	Name	Default	Description
[15:1]	RESERVED	0000H	Reserved. Set to default.
[0]	RUN	0H	Motor running status flag. 0: Motor is not running 1: Motor is running

Address 6Ch			
Bits	Name	Default	Description
[15:12]	RESERVED	0H	Reserved. Set to default.
[11:0]	VIN_SENSE	0000H	DC voltage ADC sample value. $VIN_SENSE[11:0] = V_{UVLO} / 3.3 \times K_{VIN} \times 4096$ Where K_{VIN} is the resistor-divider ratio, calculated with $R_L / (R_L + R_H)$.

Address 6D-6Fh			
Bits	Name	Default	Description
[15:0]	RESERVED	0000H	Reserved. Set to default.

Commands

Descriptions

Commands can be sent through the RS485 port. Commonly used commands include RUN, BRAKE, and UPDATE.

After the command is sent, the MP6710 operates according to the command(s).

See the Register Definition section below for details regarding each command.

Register Definition

Address 70h			
Bits	Name	Default	Description
[15:0]	RUN	0000H	Runs/stops the motor. 1: Motor runs 0: Motor stops

Address 71h			
Bits	Name	Default	Description

[15:0]	BRAKE	0000H	Brakes/runs the motor. 1: Motor brakes 0: Motor runs
--------	-------	-------	--

Address 73h			
Bits	Name	Default	Description
[15:0]	LOAD_TO_FLASH	0000H	Loads register values to the flash memory. Write 0x0002 to load all parameters to the flash memory.

Address 74h			
Bits	Name	Default	Description
[15:0]	LOAD_FROM_FLASH	0000H	Loads the register value from the flash memory.

Address 75h			
Bits	Name	Default	Description
[15:0]	FIND_BIAS	0000H	Find theta bias command.

Address 76h			
Bits	Name	Default	Description
[15:0]	UPDATE	0000H	Update command in position and speed mode.

REGISTER MAP

Addr	VALUE[15:0]
INFO	
00H	PART_NUM[15:0]
01H	MOTOR_R[15:0]
06H	MOTOR_V[15:0]
08H	MOTOR_P[15:0]
14H	PART_VER[15:0]
Position Loop Settings	
1AH	KP_POS[15:0]
1BH	KP_POS_GAIN[15:0]
1CH	SPD_LIMIT[15:0]
Position Command	
1DH	RESERVED ACCE[4:0]
1EH	POS_IN_RANGE[15:0]
48H	POS_BIAS[31:16]
49H	POS_BIAS[15:0]
4AH	POS_CMD[31:16]
4BH	POS_CMD [15:0]
4CH	POS_CMD_SLOPE[15:0]
50H	NSTEP[15:0]
Speed Loop Settings	
22H	KP_SPD[15:0]
23H	KP_SPD_GAIN [15:0]
24H	KI_SPD[15:0]
25H	KI_SPD_GAIN[15:0]
26H	KC_SPD[15:0]
27H	MAX_LIMIT_IQ[15:0]
Speed Command	
29H	SPD_IN_RANGE[15:0]
4DH	SPD_CMD [31:16]
4EH	SPD_CMD [15:0]
4FH	SPD_CMD_SLOPE[15:0]

Torque Loop Settings										
2BH	KP_CURRENT[15:0]									
2CH	KI_CURRENT[15:0]									
Torque Command										
2DH	T_MAX_SPD[15:0]									
2EH	ANTI_TORQUE_GAIN[15:0]									
2FH	RESERVED					IQ_CMD[11:0]				
Operating Mode										
34H	RESE RVED	UVLO_ EN	FEED_ FORW ARD	SCURV E	NSTEP _TYPE	PWM_ MODE	STAND BY	POS_ CMD_ TYPE	CMD_ MODE [1:0]	MODE [1:0]
Brake Mode										
37H	RESERVED			BRAKE_IQ[10:0]						
38H	BRAKE_STOP_SPEED[15:0]									
Auto Theta Bias										
3EH	I_HOLD[15:0]									
3FH	T_HOLD[15:0]									
Filters										
40H	TRACK_POS_ALPHA[15:0]									
41H	TRACK_POS_BETA[15:0]									
42H	TRACK_SPD_ALPHA[15:0]									
43H	TRACK_SPD_BETA[15:0]									
44H	RC_SPD_ALPHA[15:0]									
Protection Parameters										
53H	RESERV ED	UVLO	OTP	OVERLO AD	LOCK	OCF	PSFT	MEMORY		
54H	RESERVED			RETRY_EN			FAULT_RETRY_TIME[3:0]			
55H	RESERVED	OVERLOAD_ EN	OVERLOAD_ TIME[3:0]	RESERVED		LOCK_EN	LOCK_TIME [3:0]			
56H	VDC_LIMIT[15:1]					VDC_LIMIT_EN[0]				
57H	FSW[15:0]									
58H	DEAD_TIME[15:0]									
59H	RESERVED			AD_MODE			AD_GAIN[2:0]			
5AH	RESERVED					IOCP[9:0]				
5BH	V_UVLO[15:0]									
6BH	OTP_SET [15:0]									

Read-Only Information			
5EH	TEMPERATURE[15:0]		
5FH	POSITION[31:16]		
60H	POSITION[15:0]		
61H	SPEED[15:0]		
62H	SPEED[31:16]		
63H	RESERVED	IQ_LATCH[11:0]	
64H	RESERVED	ID_LATCH[11:0]	
65H	RESERVED	UQ_LATCH[11:0]	
66H	RESERVED	UD_LATCH[11:0]	
67H	THETA_BIAS[15:0]		
68H	RESERVED	THETA_DIR	
69H	RESERVED	SPD_REACH	POS_REACH
6AH	RESERVED	RUN	
6CH	RESERVED	VIN_SENSE[11:0]	
6DH	RESERVED		
6EH	RESERVED		
6FH	RESERVED		
RS485 Communication			
5CH	RESERVED	RS485_ADDR[6:0]	
5DH	RS485_BAUDRATE[15:0]		
Operating Command			
70H	RUN[15:0]		
71H	BRAKE[15:0]		
73H	LOAD_TO_FLASH[15:0]		
74H	LOAD_FROM_FLASH[15:0]		
75H	FIND_BIAS[15:0]		
76H	UPDATE[15:0]		

APPLICATION INFORMATION

Selecting the Input Capacitor

The input capacitor reduces the surge current drawn from the input supply and the switching noise from the device.

The input capacitor impedance at the switching frequency should be less than the input source impedance to prevent the high-frequency switching current from passing through to the input.

It is recommended to use ceramic capacitors with X5R or X7R dielectrics for their low ESR and small temperature coefficients. Higher-value capacitors are helpful to reduce input voltage ripple and noise.

Setting the Switching Frequency

A higher switching frequency leads to smaller current ripple, but higher switching loss on the MOSFETs. Select the appropriate tradeoff for the design. For most applications, a 20kHz to 40kHz frequency is recommended.

PCB Layout Guidelines

Efficient layout is critical for proper device operation. For the best results, follow the guidelines below:

1. Place the decoupling capacitor close to the VDD and LDO pins. For most applications, a 1 μ F X7R ceramic capacitor is recommended.
2. Use a wide copper area for the input, output, and GND connecting wires to improve thermal performance.
3. Place GND vias near the output and input capacitors to improve thermal performance and reduce ground impedance.
4. Connect the ground copper that is near the external sensing resistor of the power stage to the IC's GND pin with a wide copper plane.

TYPICAL APPLICATION CIRCUITS

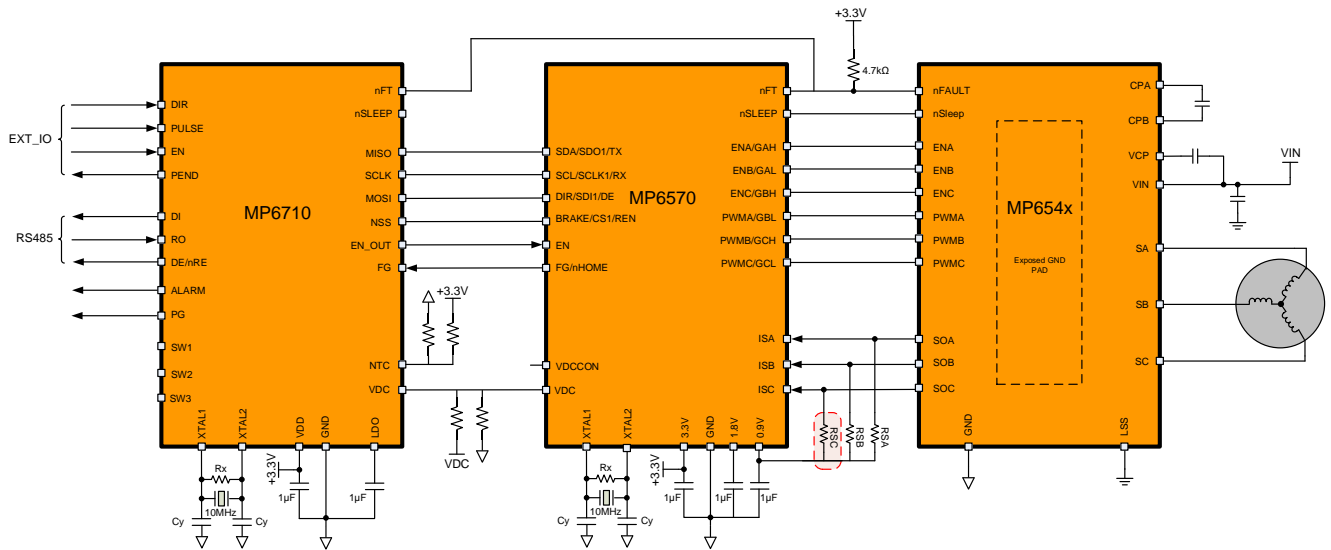

Figure 11: MP6710 + MP6570 + MP654x Solution

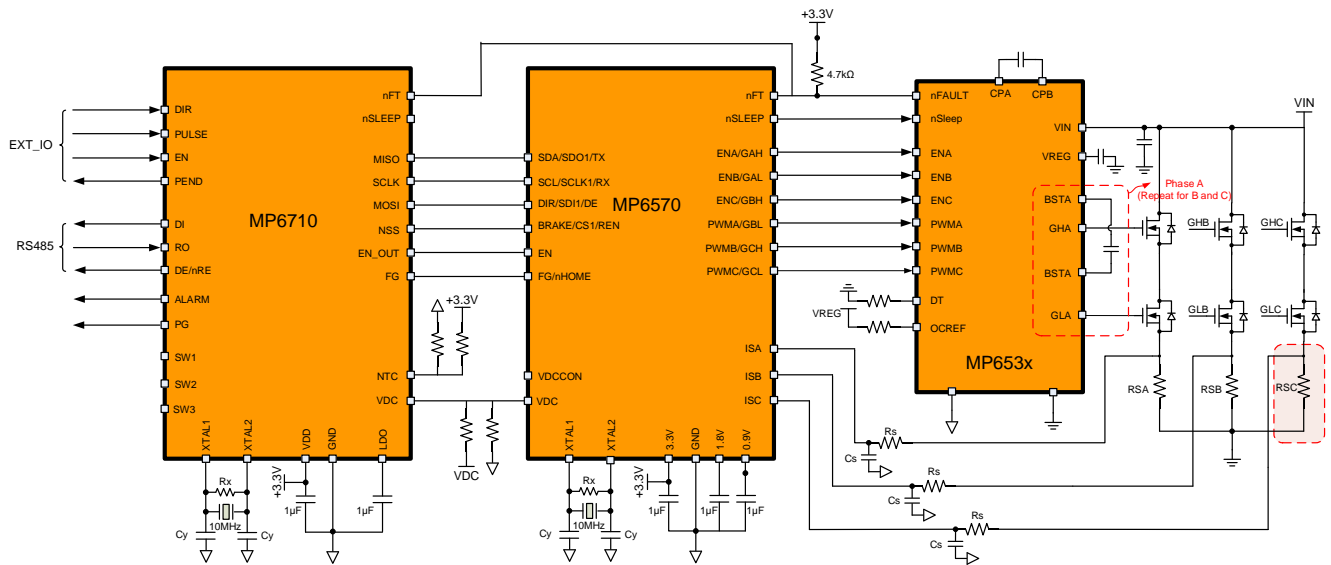
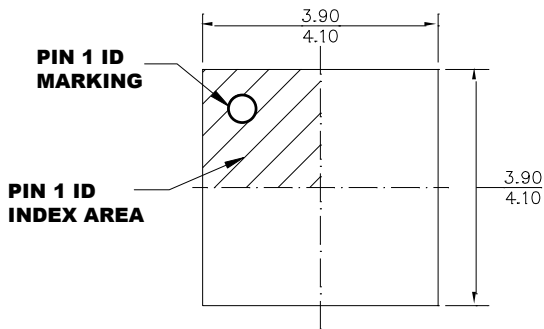

Figure 12: MP6710 + MP6570 + Pre-Driver + MOSFETs Solution

PACKAGE INFORMATION

TQFN-32 (4mmx4mm)



TOP VIEW

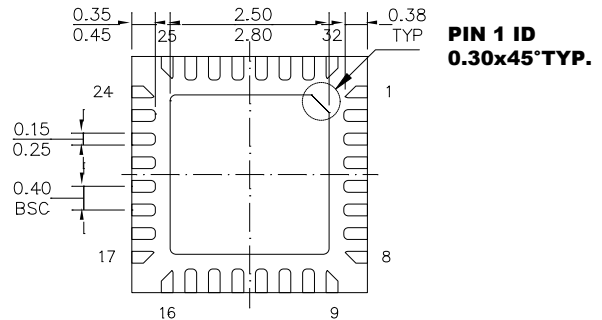

BOTTOM VIEW

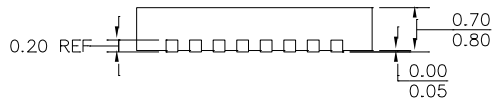

SIDE VIEW

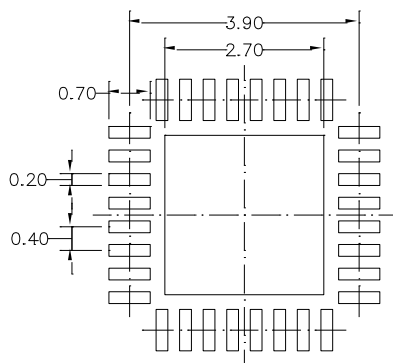

RECOMMENDED LAND PATTERN

NOTE:

- 1) ALL DIMENSIONS ARE IN MILLIMETERS.
- 2) EXPOSED PADDLE SIZE DOES NOT INCLUDE MOLD FLASH.
- 3) LEAD COPLANARITY SHALL BE 0.08 MILLIMETERS MAX.
- 4) JEDEC REFERENCE IS MO-220.
- 5) DRAWING IS NOT TO SCALE.

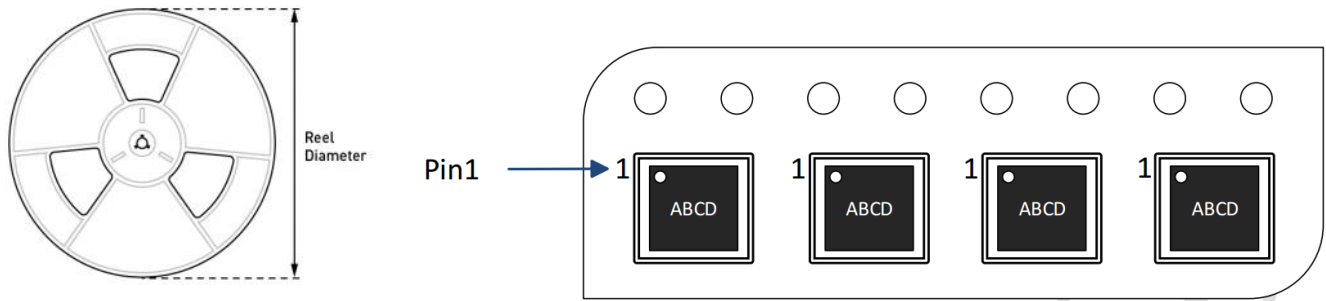
CARRIER INFORMATION

Part Number	Package Description	Quantity/Reel	Quantity/Tube	Quantity/Tray	Reel Diameter	Carrier Tape Width	Carrier Tape Pitch
MP6710GRT-Z	TQFN-32 (4mmx4mm)	5000	N/A	N/A	13in	12mm	8mm

Revision History

Revision #	Revision Date	Description	Pages Updated
1.0	5/15/2020	Initial Release	-

NOTICE: The information in this document is subject to change without notice. Users should warrant and guarantee that third-party Intellectual Property rights are not infringed upon when integrating MPS products into any application. MPS will not assume any legal responsibility for any said applications.