



The Future of Analog IC Technology®

MP6601

35V, 2.5A, Stepper Motor Driver

DESCRIPTION

The MP6601 is a stepper motor driver with parallel inputs and current regulation. Current sensing is internal and requires no external sense resistors. High integration and a small package size make the MP6601 a space-saving and cost-effective solution for bipolar stepper motor drives.

The MP6601 operates from a wide supply voltage of 4.5 - 35V and can deliver motor current up to 2.5A (depending on thermal conditions and the package). The MP6601 can operate a bipolar stepper motor in full-, half-, or quarter-step modes using internal 2-bit DACs.

Full protection features include over-current protection (OCP), input over-voltage protection (OVP), under-voltage lockout (UVLO), and thermal shutdown.

The MP6601 is available in QFN-24 (5mmx5mm) and TSSOP-28 EP packages.

FEATURES

- Wide 4.5V to 35V Input Voltage Range
- Two Internal Full-Bridge Drivers
- Internal Current Sensing and Regulation
- Low On Resistance (HS: 170mΩ, LS: 150mΩ)
- No Control Power Supply Required
- Simple PHASE/I0/I1 Logic Interface
- 3.3V and 5V Compatible Logic Supply
- Step Modes from Full-Step to Quarter-Step
- 2.5A Output Current
- Automatic Current Decay
- Over-Current Protection (OCP)
- Input Over-Voltage Protection (OVP) Function
- Thermal Shutdown and Under-Voltage Lockout (UVLO) Protection
- Fault Indication Output
- Available in QFN-24 (5mmx5mm) and Thermally Enhanced TSSOP-28 EP Packages

APPLICATIONS

- Bipolar Stepper Motors
- Printers

All MPS parts are lead-free, halogen-free, and adhere to the RoHS directive. For MPS green status, please visit the MPS website under Quality Assurance. "MPS" and "The Future of Analog IC Technology" are registered trademarks of Monolithic Power Systems, Inc.

TYPICAL APPLICATION

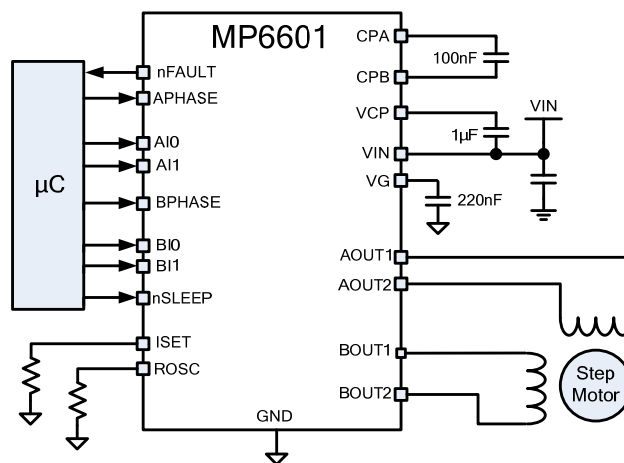

ORDERING INFORMATION

Part Number*	Package	Top Marking
MP6601GU	QFN-24 (5mmx5mm)	See Below
MP6601GF	TSSOP-28 EP	See Below

* For Tape & Reel, add suffix -Z (e.g.: MP6601GU-Z)

TOP MARKING (MP6601GU)

MPSYYWW
MP6601
LLLLLLL

TOP MARKING (MP6601GF)

MPSYYWW
MP6601
LLLLLLLLL

MPS: MPS prefix
 YY: Year code
 WW: Week code
 MP6601: Product code of MP6601GU
 LLLLLLL: Lot number

MPS: MPS prefix
 YY: Year code
 WW: Week code
 MP6601: Product code of MP6601GF
 LLLLLLLLL: Lot number

PACKAGE REFERENCE

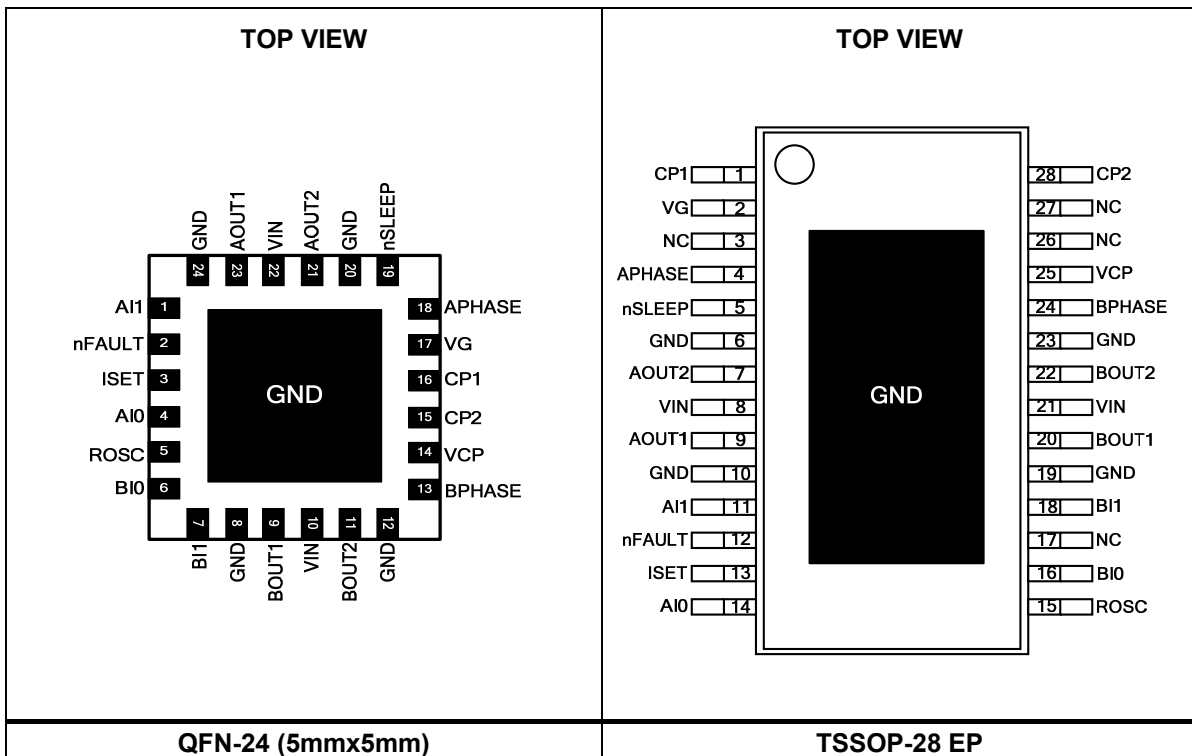



ABSOLUTE MAXIMUM RATINGS (1)

Supply voltage (V _{IN})	-0.3V to 40V
xOUTx voltage (V _{A/BOU1/2})	-0.7V to 40V
VCP, CPB	V _{IN} to V _{IN} + 6.5V
ESD rating (HBD).....	2kV
All other pins to AGND.....	-0.3V to 6.5V
Continuous power dissipation (T_A = +25°C) (2)	
QFN-24 (5mmx5mm).....	3.5W
TSSOP-24 EP.....	3.9W
Storage temperature	-55°C to +150°C
Junction temperature	+150°C
Lead temperature (solder)	+260°C

Recommended Operating Conditions (3)

Supply voltage (V _{IN})	4.5V to 35V
Operating junction temp. (T _J)....	-40°C to +125°C

Thermal Resistance (4)	θ_{JA}	θ_{JC}	
QFN-24 (5mmx5mm).....	36	8	°C/W
TSSOP-28 EP.....	32	6	°C/W

NOTES:

- 1) Exceeding these ratings may damage the device.
- 2) The maximum allowable power dissipation is a function of the maximum junction temperature T_J (MAX), the junction-to-ambient thermal resistance θ_{JA}, and the ambient temperature T_A. The maximum allowable continuous power dissipation at any ambient temperature is calculated by P_D (MAX) = (T_J (MAX)-T_A)/θ_{JA}. Exceeding the maximum allowable power dissipation produces an excessive die temperature, causing the regulator to go into thermal shutdown. Internal thermal shutdown circuitry protects the device from permanent damage.
- 3) The device is not guaranteed to function outside of its operating conditions.
- 4) Measured on JESD51-7, 4-layer PCB.

ELECTRICAL CHARACTERISTICS

$V_{IN} = 24V$, $T_A = +25^{\circ}C$, unless otherwise noted.

Parameter	Symbol	Condition	Min	Typ	Max	Units
Power Supply						
Input supply voltage	V_{IN}		4.5	24	35	V
Quiescent current	I_Q	$V_{IN} = 24V$, nSLEEP = 1, with no load		1.5	5	mA
	I_{SLEEP}	$V_{IN} = 24V$, nSLEEP = 0			1	μA
Internal MOSFETs						
Output on resistance	R_{HS}	$V_{IN} = 24V$, $I_{OUT} = 1A$, $T_J = 25^{\circ}C$		0.195	0.23	Ω
		$V_{IN} = 24V$, $I_{OUT} = 1A$, $T_J = 85^{\circ}C$ ⁽⁵⁾		0.25		Ω
	R_{LS}	$V_{IN} = 24V$, $I_{OUT} = 1A$, $T_J = 25^{\circ}C$		0.17	0.22	Ω
		$V_{IN} = 24V$, $I_{OUT} = 1A$, $T_J = 85^{\circ}C$ ⁽⁵⁾		0.25		Ω
Body diode forward voltage	V_F	$I_{OUT} = 1.5A$			1.1	V
Control Logic						
Input logic low threshold	V_{IL}				0.8	V
Input logic high threshold	V_{IH}		2.1			V
Logic input current	$I_{IN(H)}$	$V_{IH} = 5V$			20	μA
	$I_{IN(L)}$	$V_{IL} = 0.8V$			5	μA
Internal pull-down resistance	R_{PD}			500		k Ω
Home nFAULT Outputs (Open-Drain Outputs)						
Output low voltage	V_{OL}	$I_O = 5mA$			0.5	V
Output high leakage current	I_{OH}	$V_O = 3.3V$			1	μA
Protection Circuit						
UVLO rising threshold	V_{IN_RISE}			3.4	4.5	V
UVLO hysteresis	V_{HYS}			300		mV
Input OVP threshold	V_{OVP}		36	37.5	38.5	V
Input OVP hysteresis	ΔV_{OVP}			1900		mV
Over-current trip level	I_{OCP1}	Sinking	3	6	8	A
	I_{OCP2}	Sourcing	3	6	8	A
Over-current deglitch time ⁽⁵⁾	t_{OCP}			1		μs
Thermal shutdown ⁽⁵⁾	T_{TSD}			165		$^{\circ}C$
Thermal shutdown hysteresis ⁽⁵⁾	ΔT_{TSD}			15		$^{\circ}C$
Current Control						
Constant off time	t_{OFF}	$R_t = 200k\Omega$	20	23	26	μs
Blanking time ⁽⁵⁾	t_{BLANK}			2		μs
Peak current regulation level	I_{PEAK}	$R_{ISET} = 71k\Omega$	0.95	1.0	1.05	A
ISET voltage	V_{ISET}			0.9		V
ISET current ratio	A_{ISET}	I_{ISET}/I_{OUT}	11	12.676	14	$\mu A/A$
Current trip accuracy	ΔI_{TRIP}	$R_{ISET} = 71k\Omega$, 71 - 100%	-5		5	%
		$R_{ISET} = 71k\Omega$, 38 - 67%	-10		10	%

NOTE:

5) Guaranteed by design.

TYPICAL CHARACTERISTICS

ISET Voltage vs. Temperature

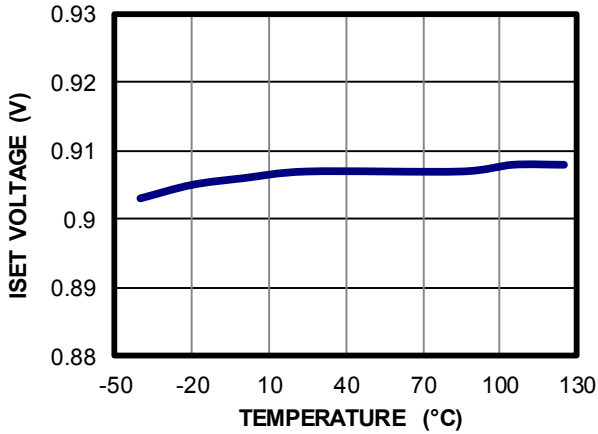

ISET Current Ratio vs. Temperature

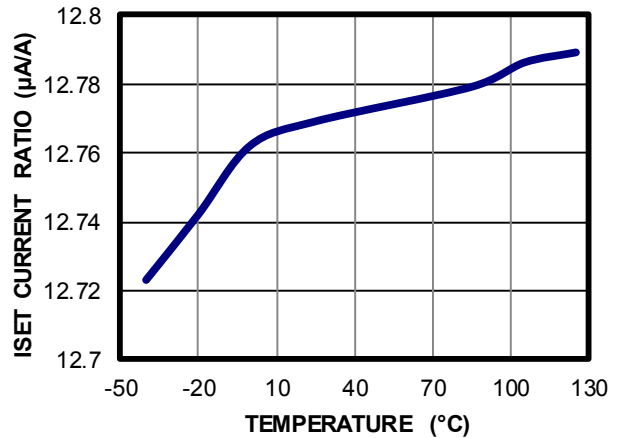

Bridge A HS On Resistance vs. Temperature

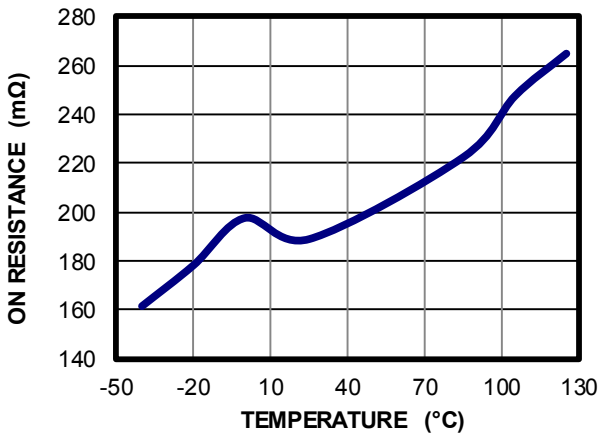

Bridge B HS On Resistance vs. Temperature

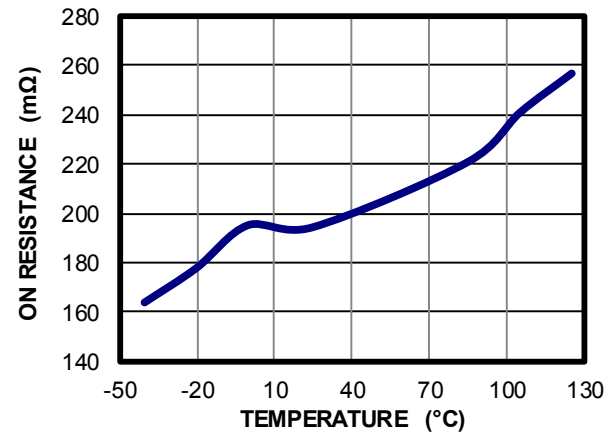

Bridge A LS On Resistance vs. Temperature

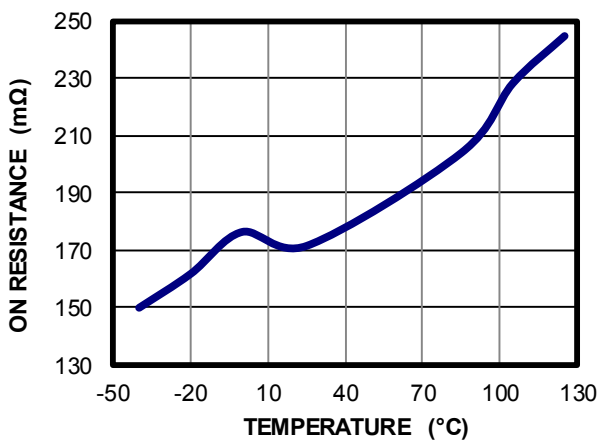

Bridge B LS On Resistance vs. Temperature

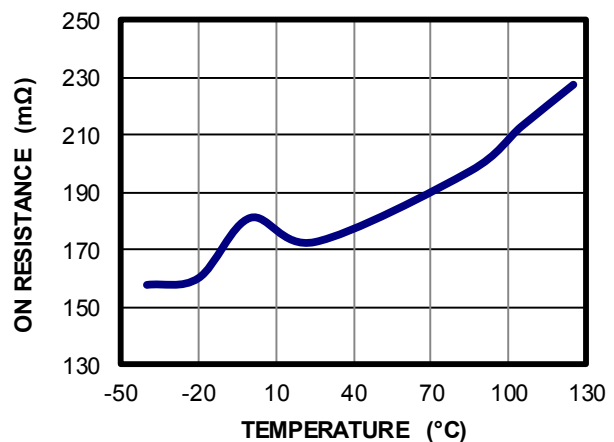

TYPICAL CHARACTERISTICS *(continued)*

Input OVP Threshold vs. Temperature

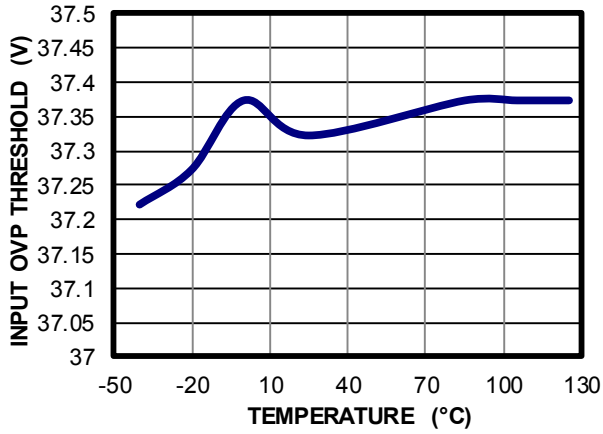

TYPICAL PERFORMANCE CHARACTERISTICS *(continued)*

$V_{IN} = 24V$, $I_{OUT} = 2.5A$, 1/4-step, $T_A = 25^{\circ}C$, resistor + inductor load: $R = 3.3\Omega$, $L = 1.5mH/channel$, unless otherwise noted.

Normal Operation

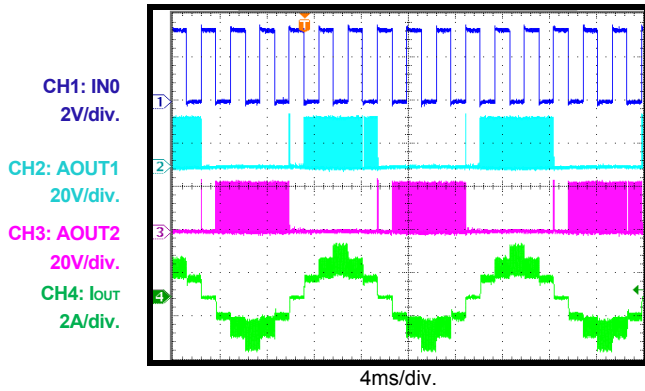

VIN Power Start-Up

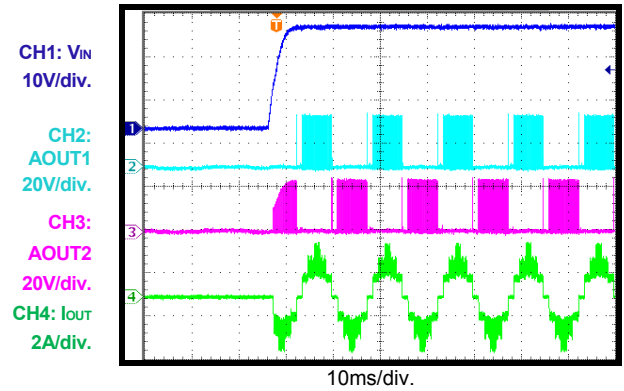

VIN Power Shutdown

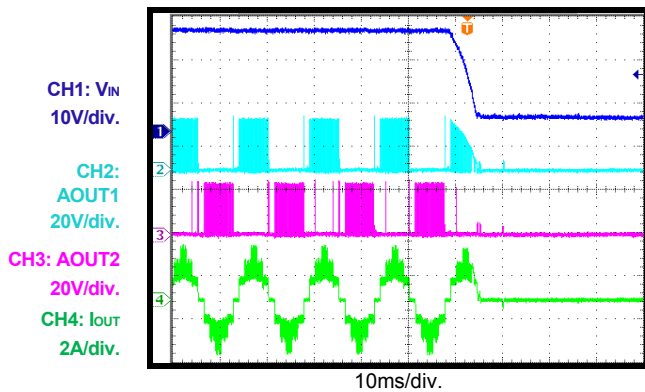

Sleep Entry

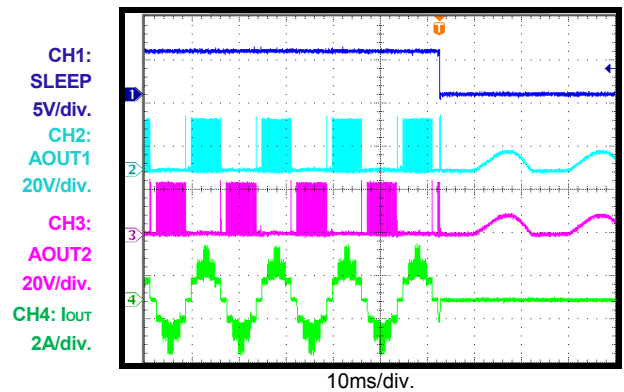

Sleep Recovery

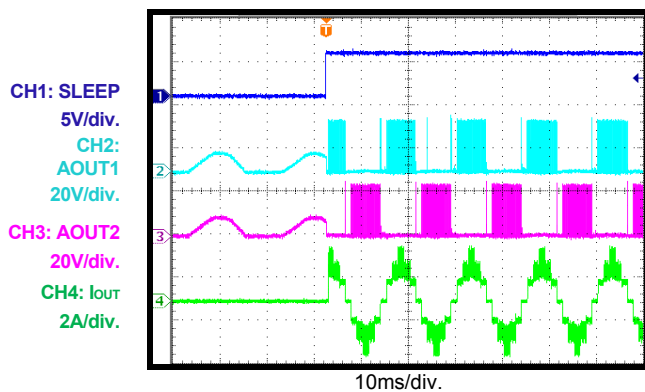

PIN FUNCTIONS

Pin # QFN	Pin # TSSOP	Name	Description
1	11	AI1	Current-set inputs for phase A.
2	12	nFAULT	Fault indication. nFAULT is an open-drain output. nFAULT is at logic low when a fault condition occurs (i.e.: OCP, OTP, OVP).
3	13	ISET	Current set programming pin. Connect a resistor from ISET to ground to set the current through the motor.
4	14	AI0	Current-set inputs for phase A.
5	15	ROSC	Constant off time programming pin. Connect a resistor from ROSC to ground to set the PWM off time.
6	16	BI0	Current-set inputs for phase B.
7	18	BI1	
8, 12, 20, 24, EP	6, 10, 19, 23, EP	GND	Power ground.
9	20	BOUT1	Bridge B output terminal 1.
10, 22	8, 21	VIN	Input supply voltage. Both VIN pins must be connected to the same supply. Decouple VIN to ground with a minimum 100nF ceramic capacitor.
11	22	BOUT2	Bridge B output terminal 2.
13	24	BPHASE	Phase (direction) input for bridge B.
14	25	VCP	Charge pump output. Connect a 1 μ F, 16V ceramic capacitor from VCP to VIN.
15	28	CP2	Charge pump capacitor. Connect a 100nF ceramic capacitor rated for the VIN voltage between these terminals.
16	1	CP1	
17	2	VG	Low-side MOSFETs gate drive voltage. Connect a 220nF, 16V ceramic capacitor from VG to ground.
-	3, 17, 26, 27	NC	No connection.
18	4	APHASE	Phase (direction) input for bridge A.
19	5	nSLEEP	Sleep mode input. Drive nSLEEP to logic low to place the MP6601 in low-power sleep mode. Drive nSLEEP to logic high to enable normal operation. nSLEEP has an internal pull-down resistor.
21	7	AOUT2	Bridge A output terminal 2.
23	9	AOUT1	Bridge A output terminal 1.

BLOCK DIAGRAM

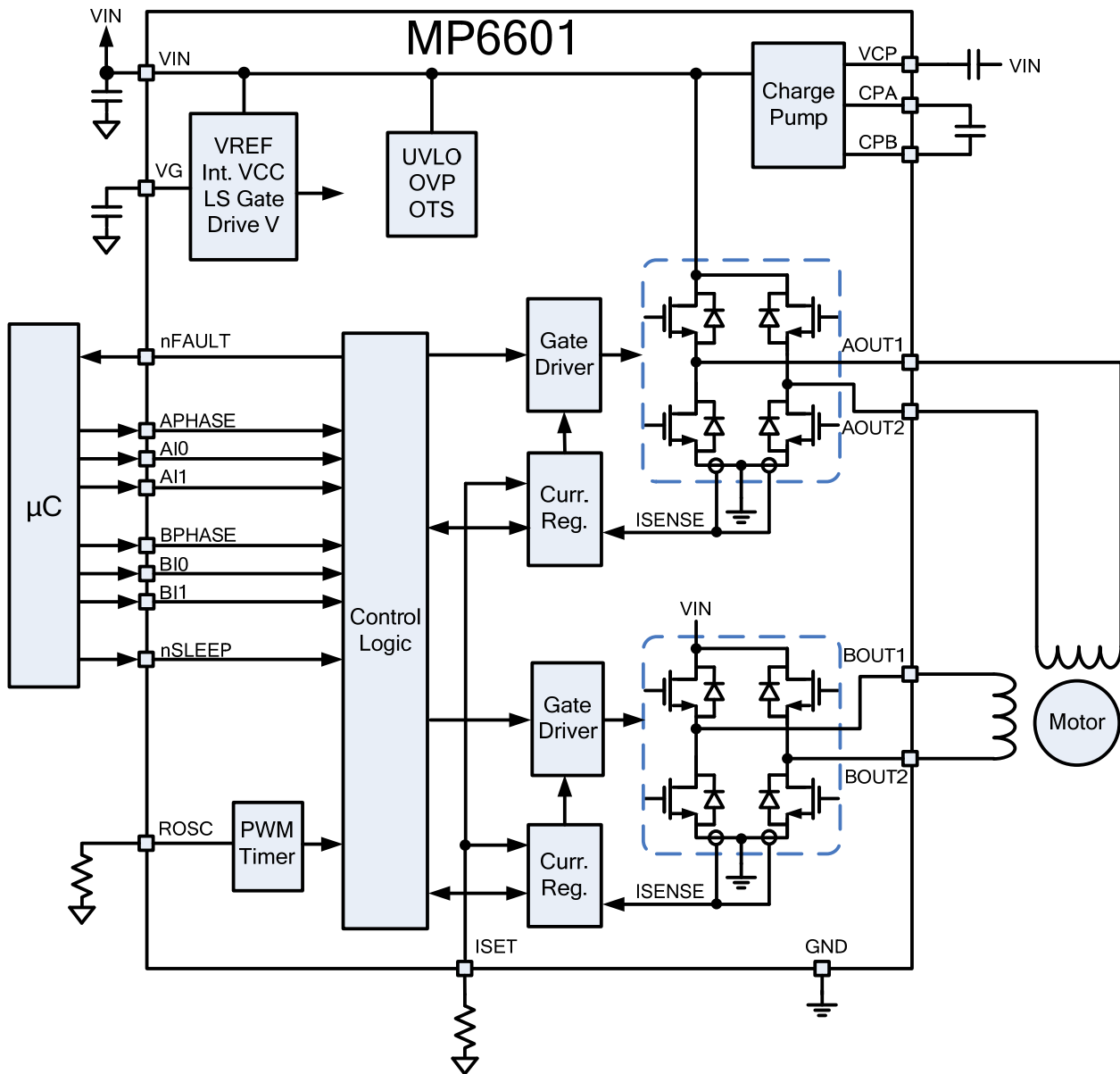

Figure 1: Functional Block Diagram

OPERATION

The MP6601 is a bipolar stepper motor driver that integrates eight N-Channel power MOSFETs comprised of two internal full-bridges with 2.5A of current capability. The MP6601 operates over a wide supply voltage range of 4.5 - 35V.

The MP6601 is designed to operate bipolar stepper motors in full-, half-, and quarter-step modes. The current of each full-bridge is set by the output voltage of an internal DAC, which is controlled by the xI0 and xI1 input pins.

The currents in each of the two outputs are regulated with programmable, constant off-time, pulse-width modulation (PWM) control circuitry. The MP6601 integrates internal current sensing, eliminating the need for external sense resistors.

Input Interface

The MP6601 contains two full H-bridges that operate independently. Each H-bridge has an input signal that controls the current flow direction in the H-bridge (see Table 1).

Table 1: Input Control Truth Table

xPHASE	xOUT1	xOUT2
0	L	H
1	H	L

Additionally, each H-bridge has two input pins that are used to scale the current regulation point in the bridge (see Table 2).

Table 2: Current Regulator Sensing

xI1	xI0	Current
0	0	100%
0	1	71%
1	0	38%
1	1	0% (high impedance)

Programmable Constant Off-Time Current Control

The motor current is regulated by a programmable constant off-time PWM current control circuit. Its operation is described below:

- Initially, a diagonal pair of MOSFETs turns on and drives current through the motor winding.
- The current increases in the motor winding, which is sensed by an internal current-sense circuit. During the initial blanking time

(t_{BLANK}), the high-side MOSFET (HS-FET) always turns on in spite of current-limit detection.

- When the current reaches the current trip threshold, the internal current comparator either shuts off the HS-FET so the winding inductance current freewheels through the two low-side MOSFETs (LS-FET) (slow decay) or turns on another diagonal pair of MOSFETs so the current flows back to the input (fast decay).
- The current keeps decreasing for the constant off-time unless a zero current level is detected. Afterward, the HS-FET is enabled to increase the winding current again.
- The cycle then repeats.

Constant-off-time (t_{off}) is determined by the selection of an external resistor (R_t), which can be approximated with Equation (1):

$$t_{OFF}(\text{ns}) = 190 \times R_t(\text{k}\Omega) \quad (1)$$

The full-scale (100%) regulation current can be calculated with Equation (2):

$$I_{Max} = 71\text{k}\Omega / R_{ISET} \quad (2)$$

Blanking Time

There is usually a current spike during the switching transition due to the body diode's reverse-recovery current or the distributed inductance or capacitance. This current spike requires filtering to prevent it from erroneously shutting down the HS-FET.

After the PWM cycle begins, the output of the current sense comparator is ignored for the fixed blanking time. This blanking time results in a minimum on time for the PWM cycle.

Automatic Decay Mode

The MP6601 uses a fully automatic decay mode to provide accurate current regulation.

Initially, slow decay is used. At the end of the fixed off time, if the current is above the I_{TRIP} threshold, then fast decay mode is initiated by reversing the state of the H-bridge outputs.

Once the current level during this fast decay period drops below the I_{TRIP} threshold,

slow decay is engaged again for another fixed off time. After the completion of this second fixed off time, a new PWM cycle begins.

Figure 2 shows the automatic decay mode operation during a current reduction as a result of a change in xI0 or xI1.

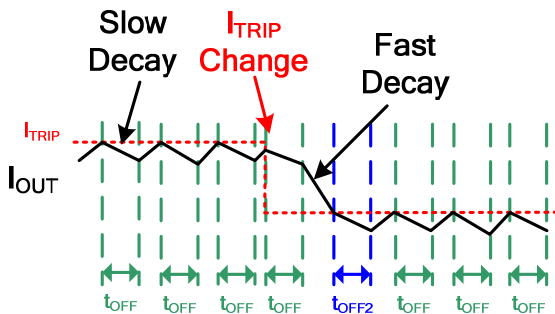

Figure 2: Slow Decay during t_{OFF} Unless $I_{OUT} > I_{TRIP}$ at End of t_{OFF}

In some cases (specifically high voltage and low inductance or regulation of very small currents), the minimum on time of the PWM cycle (set by the blanking time described above) can cause the current to rise very quickly. In this case, both slow and fast decay are used (see Figure 3).

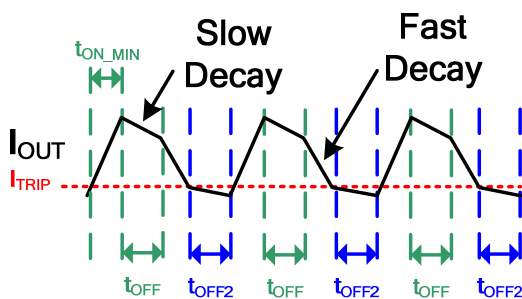

Figure 3: Current Regulation of Low Current/Low Inductance

Sleep Operation (nSLEEP)

Driving nSLEEP low puts the device into a low-power sleep state. In this state, the gate drive charge pump is stopped, and all internal circuits and H-bridge outputs are disabled. All inputs are ignored when nSLEEP is active low.

When waking up from sleep mode, approximately 1ms of time must pass before issuing a step command to allow the internal circuitry time to stabilize. nSLEEP has an internal pull-down resistor.

Fault (nFAULT)

The MP6601 provides an nFAULT pin that reports to the system if a fault condition occurs, such as over-current protection (OCP), over-temperature protection (OTP), or over-voltage protection (OVP). nFAULT is an open-drain output type and is driven low when a fault condition occurs. If the fault condition is released, nFAULT is pulled high by an external pull-up resistor.

Over-Current Protection (OCP)

OCP circuitry limits the current through the MOSFETs by disabling the gate driver. If the current reaches the over-current limit threshold and stays there for longer than the over-current deglitch time, all MOSFETs in the H-bridge are disabled, and nFAULT is driven low. The driver is disabled for 5ms, typically. Afterward, the driver is re-enabled automatically.

Over-current conditions on both the high- and low-side devices (i.e.: a short to ground, supply, or across the motor winding) result in an over-current shutdown. Note that OCP does not use the current-sense circuitry used for PWM current control.

Over-Voltage Protection (OVP)

If the input voltage on VIN is higher than the OVP threshold, the H-bridge output is disabled, and nFAULT is driven low. This protection is released when VIN drops below 38V.

Input UVLO Protection

If at any time the voltage on VIN falls below the under-voltage lockout (UVLO) threshold voltage, all circuitry in the device is disabled, and the internal logic is reset. Operation resumes when VIN rises above the UVLO threshold.

Thermal Shutdown

If the die temperature exceeds safe limits, all MOSFETs in the H-bridge are disabled, and nFAULT is driven low. Once the die temperature has fallen to a safe level, operation resumes automatically.

APPLICATIONS INFORMATION

Driving DC Brush Motors

The MP6601 can be used to drive two DC brush motors. The connections are shown in Figure 4 below:

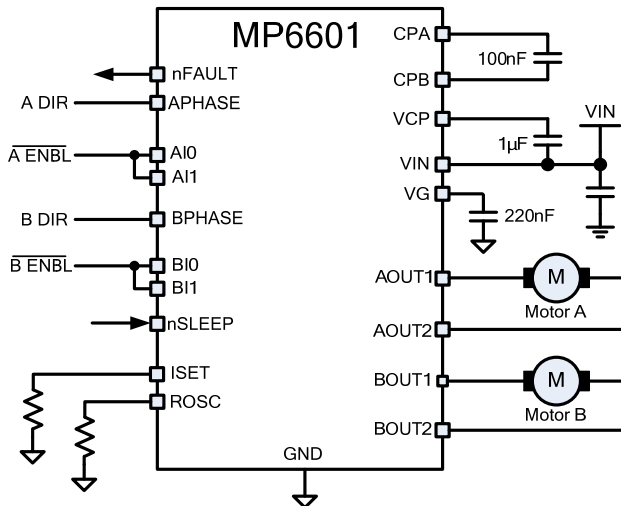

Figure 4: DC Brush Motor Connection

When driving DC motors with the MP6601, there are some limitations that must be taken into account.

Since both H-bridges use the same current regulation threshold, both motors will current limit at the same current. Often, current regulation is not used with DC brush motors; in this case, it is recommended to select a 28kΩ ISET resistor to set the current limit at 2.5A. If it is desired to limit the stall current of the motors to a lower value, select an appropriate value for the ISET resistor as described in Equation (2) above.

The MP6601 does not support the short brake function, where both outputs are connected together. The enable signal shown above drives the motor when low, and the motor coasts when high. Speed control can be implemented by applying a PWM signal to the enable signals. Bidirectional control can be accomplished by applying a PWM signal to the direction inputs – duty cycles above 50% will cause rotation in one direction, and less than 50% will cause rotation in the other direction.

PCB Layout

The power dissipated in the output MOSFETs must be removed from the IC package to keep the device temperature within limits. The exposed pad under the device is used to conduct heat out of the die.

The pad should be connected to a large copper area or ground plane, using thermal vias to transmit heat to other layers as needed.

External components, including the ISET and ROSC resistors and a supply bypass capacitors, should be placed as close as possible to the device.

PACKAGE INFORMATION

QFN-24 (5mmx5mm)

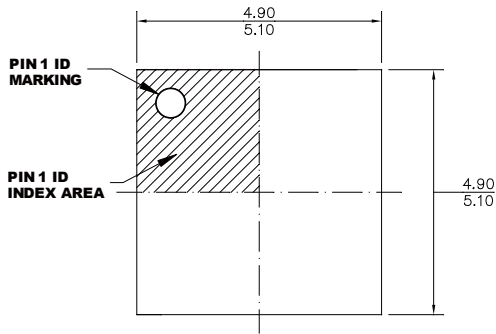

TOP VIEW

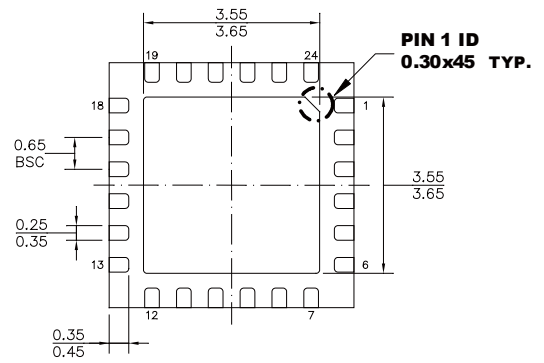

BOTTOM VIEW



SIDE VIEW

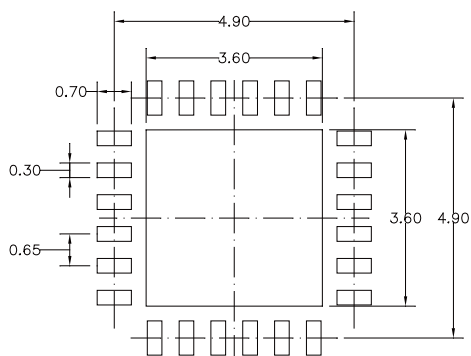

RECOMMENDED LAND PATTERN

NOTE:

- 1) ALL DIMENSIONS ARE IN MILLIMETERS
- 2) EXPOSED PADDLE SIZE DOES NOT INCLUDE MOLD FLASH
- 3) LEAD COPLANARITY SHALL BE ≤ 0.10 MILLIMETERS MAX
- 4) DRAWING CONFIRMS TO JEDEC MQ220.
- 5) DRAWING IS NOT TO SCALE

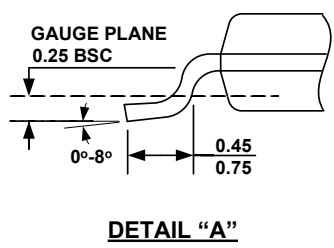
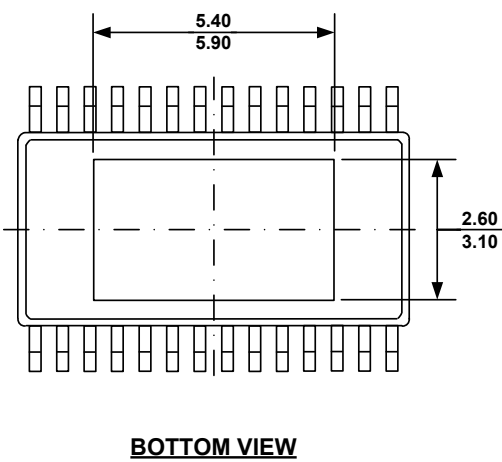
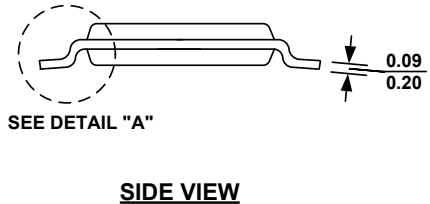
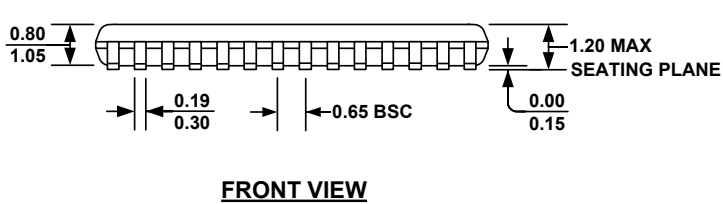
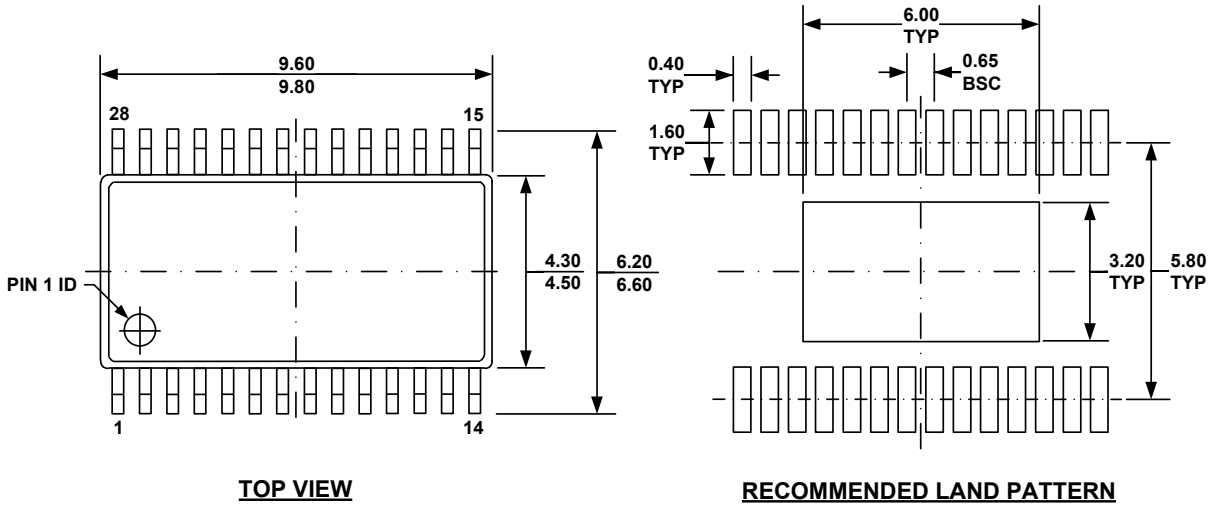
PACKAGE INFORMATION (continued)
TSSOP-28 EP

- NOTE:**
- 1) ALL DIMENSIONS ARE IN MILLIMETERS.
 - 2) PACKAGE LENGTH DOES NOT INCLUDE MOLD FLASH, PROTRUSION OR GATE BURR.
 - 3) PACKAGE WIDTH DOES NOT INCLUDE INTERLEAD FLASH OR PROTRUSION.
 - 4) LEAD COPLANARITY (BOTTOM OF LEADS AFTER FORMING) SHALL BE 0.10 MILLIMETERS MAX.
 - 5) DRAWING CONFORMS TO JEDEC MO-153, VARIATION AET.
 - 6) DRAWING IS NOT TO SCALE.

NOTICE: The information in this document is subject to change without notice. Please contact MPS for current specifications. Users should warrant and guarantee that third party Intellectual Property rights are not infringed upon when integrating MPS products into any application. MPS will not assume any legal responsibility for any said applications.