



The Future of Analog IC Technology®

MP5920

Hot-Swap Controller and Energy Monitor with PMBus Interface

DESCRIPTION

The MP5920 is a hot-swap protection controller designed to protect circuitry on its output from transients on its input. The MP5920 allows a circuit board to be removed from or inserted into a live backplane and protects its input from undesired shorts and transients coming from its output.

The MP5920 works with an Intelli-Fuse, which can feed back the current, voltage, and temperature information to the MP5920. The Intelli-Fuse can be turned on or off through the ON pin. The MP5920 limits the Intelli-Fuse maximum load current by controlling the current limit reference voltage through CLPWM.

The MP5920 can be configured to a single output easily with several fuses in parallel.

The PMBus interface allows the MP5920 to read current, voltage, or temperature data and input power from a 12-bit ADC.

The MP5920 is available in a 32-pin TQFN (4mmx4mm) package.

FEATURES

- Easily Configure to a Single Output with Intelli-Fuses in Parallel
- Controllable Intelli-Fuse On or Off through ON
- Programmable Parameters through PMBus
- Programmable Current Limit Reference Voltage for Intelli-Fuse Current Limit Set
- Precision Current Sensing and Temperature Sensing from Intelli-Fuse
- PMBus Fast Mode Compliant
- Built-In 12-Bit ADC for Current, V_{IN} , V_{OUT} , or Temperature Reading
- Programmable Average Time
- Reports Power and Energy Consumption
- Available in a TQFN-32 (4mmx4mm) Package

APPLICATIONS

- Hot Swap
- PC Cards
- Disk Drives
- Servers
- Networking
- Laptops

All MPS parts are lead-free, halogen-free, and adhere to the RoHS directive. For MPS green status, please visit the MPS website under Quality Assurance. "MPS" and "The Future of Analog IC Technology" are registered trademarks of Monolithic Power Systems, Inc.

TYPICAL APPLICATION

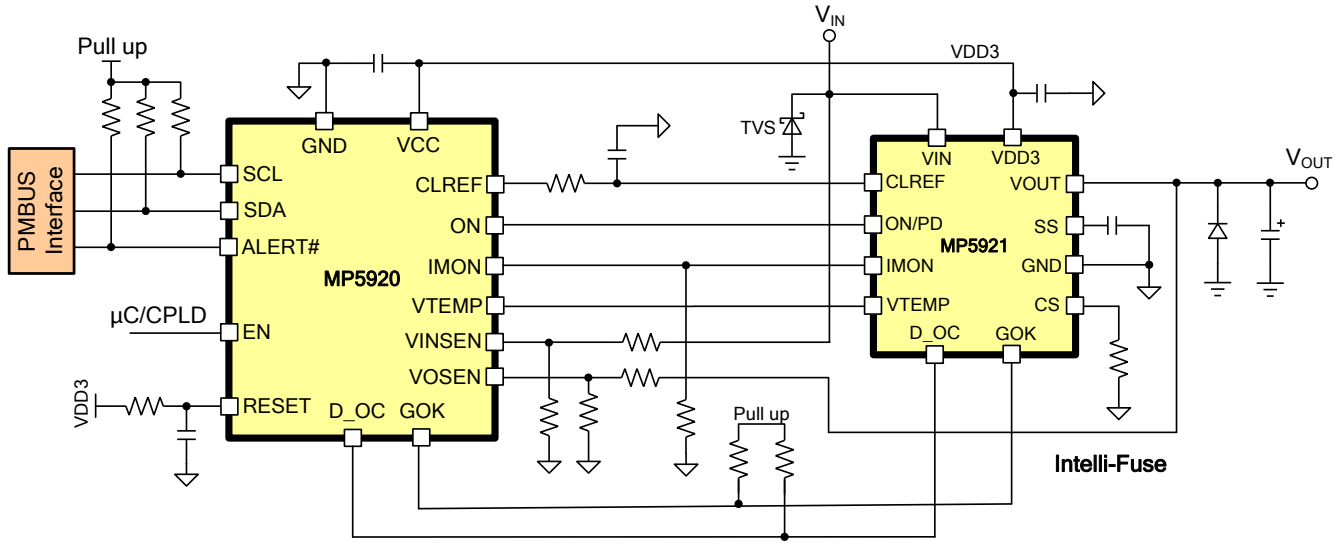

MP5920 + MP5921 with Dynamic Max Current Limit via CLREF

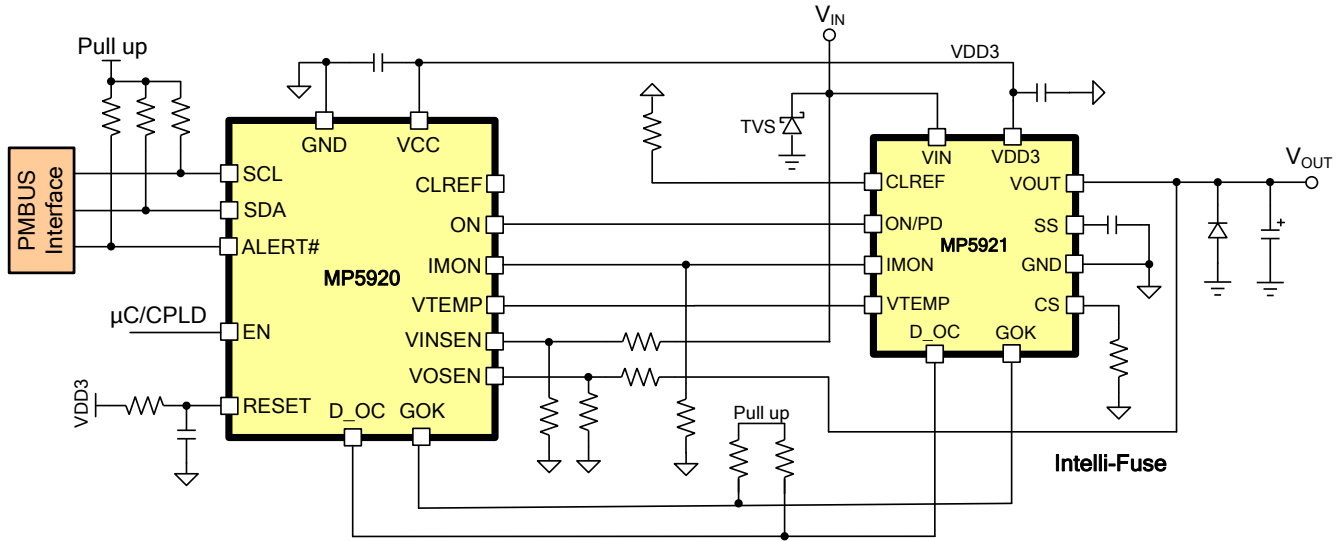

MP5920 + MP5921 with Static Max Current Limit

ORDERING INFORMATION

Part Number*	Package	Top Marking
MP5920GRT-xxxx**	TQFN-32 (4mmx4mm)	<i>See Below</i>

* For Tape & Reel, add suffix -Z (e.g. MP5920GRT-xxxx-Z)

** "xxxx" is the configuration code identifier for the register settings. Each "x" can have a hexadecimal value between 0 and F. Please work with an MPS FAE to create this unique number.

TOP MARKING

MPSYWW

MP5920

LLLLLL

MPS: MPS prefix
 Y: year code
 WW: week code
 MP5920: part number
 LLLLLL: lot number

PACKAGE REFERENCE

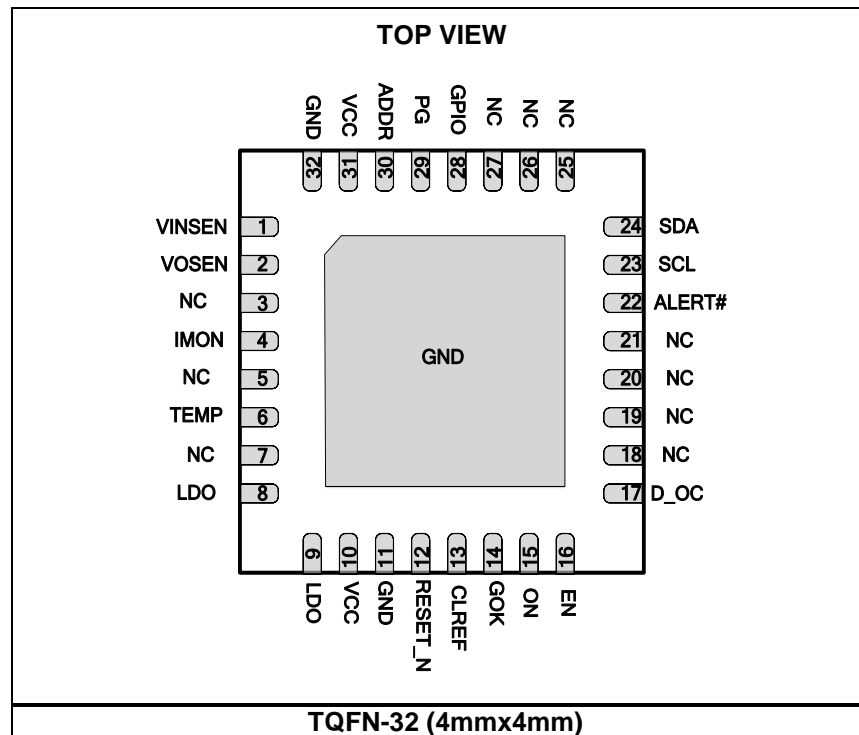

ABSOLUTE MAXIMUM RATINGS ⁽¹⁾

Supply voltage (VCC)3.6V
RESET_N..... -0.5V to +3.6V
All other pins..... -0.5V to VCC + 0.5V
Storage temperature..... -55°C to +150°C

Recommended Operating Conditions ⁽²⁾

VCC.....+3.3V
Operating junction temp. (T_J) -40°C to +85°C

Thermal Resistance ⁽³⁾ θ_{JA} θ_{JC}
TQFN-32 (4mmx4mm) 474.5... °C/W

NOTES:

- 1) Exceeding these ratings may damage the device.
- 2) The device is not guaranteed to function outside of its operating conditions.
- 3) Measured on JESD51-7, 4-layer PCB.

ELECTRICAL CHARACTERISTICS ⁽⁴⁾
VCC = 3.3V, T_A = 25°C, unless otherwise noted.

Parameters	Symbol	Condition	Min	Typ	Max	Units
Power Supply						
Operating voltage range	V _{CC}			3.3	3.6	V
Quiescent current	I _{CC}	VCC = 3.3V		10		mA
Power-On Reset (POR)						
Release threshold of POR	V _{ROT}	VCC rising	1.66	1.79	1.9	V
RESET_N						
RESET_N threshold voltage	V _{RST}		0.2V _{CC}		0.9V _{CC}	V
Minimum pulse width on RESET_N	t _{RST}	VCC = 3.3V		700		ns
Time-out after reset	t _{TOUT}			64	128	ms
CLREF						
Frequency	f _{CLREF}	VCC = 3.3V		50		kHz
ON						
Output low voltage	V _{OL_ON}	I _{OL} = 5mA			0.5	V
Output high voltage	V _{OH_ON}		2.5			V
Off-state leakage current	I _{ON_LKG}	V _{ON} = 3.3V			1	μA
GOK						
Input high voltage	V _{IH}		0.6V _{CC}			V
Input low voltage	V _{IL}				0.3V _{CC}	V
Off-state leakage current	I _{GOK_LKG}				1	μA
D_OC INPUT						
Input high voltage	V _{IH}		0.6V _{CC}			V
Input low voltage	V _{IL}				0.3V _{CC}	V
Off-state leakage current	I _{GOK_LKG}				1	μA
ADC						
Voltage range			0		VCC	V
Resolution				12		bits
Integral non-linearity	INL			±2	5	LSB
Sample rate				36		kHz
ADC conversion output			0		4095	LSB
PMBus DC Characteristics						
Input high voltage	V _{IH}	SCL, SDA	0.7V _{CC}		V _{CC} +0.5	V
Input low voltage	V _{IL}	SCL, SDA	-0.5		0.3V _{CC}	V
Output low voltage	V _{OL}	SDA, ALERT#, 3mA sink current			0.4	V

ELECTRICAL CHARACTERISTICS ⁽⁴⁾
VCC = 3.3V, T_A = 25°C, unless otherwise noted.

Parameters	Symbol	Condition	Min	Typ	Max	Units
PMBus Timing Characteristics						
Spikes suppressed by input filter	t _{SP}		0		50	ns
Operating frequency range	f _{SCL}				1000	kHz
Hold time (repeated) start condition	t _{HD:STA}		0.6		-	μs
Low period of SCL clock	t _{LOW}		1.3		-	μs
High period of SCL clock	t _{HIGH}		0.6		-	μs
Set-up time for repeated start condition	t _{SU:STA}		0.6			μs
Data hold time	t _{HD:DAT}		0		0.9	μs
Data setup time	t _{SU:DAT}		100			ns
Set-up time for stop condition	t _{SU:STO}		0.6		-	μs
Bus free time between stop and start condition	t _{BUF}		1.3		-	μs

NOTE:

4) Sampled during initial release to ensure compliance, not subject to production testing.

PIN FUNCTIONS

Pin #	Name	Description
1	VINSEN	Input rail voltage sense input. VINSEN is used to read back the input voltage using the internal ADC. Connect VINSEN to the V_{IN} rail through a resistor divider.
2	VOSEN	Output voltage sense input. VOSEN is used to read back the output voltage using the internal ADC. Connect VOSEN to the main rail output through a resistor divider.
3, 5, 7, 18 -21, 25 - 27	NC	No connection.
4	IMON	Current monitor input from Intelli-Fuse. IMON is used to read back the load current using the internal ADC. Connect the IMON signals from the main rail Intelli-Fuse to IMON with a resistor to GND. IMON provides a voltage that corresponds to the load current.
6	TEMP	Intelli-Fuse temperature sensing. Connect TEMP to the VTEMP pin of Intelli-Fuse. Connect all VTEMP pins from the main rail Intelli-Fuse together to produce the maximum junction temperature before connecting to the MP5920's TEMP pin. The voltage at VTEMP is measured by the internal ADC.
8, 9	LDO	Internal LDO output. Decouple LDO with a 4.7 μ F ceramic capacitor.
10	VCC	3 - 3.3V power supply input. Bypass VCC with a 1 μ F ceramic capacitor to ground.
11, 32	GND	Ground.
12	RESET_N	Analog POR reset for the IC. When the voltage is above the threshold, the MP5920 begins operation. Connect RESET_N to VCC through a 4.7k Ω resistor and a 10nF capacitor to ground.
13	CLREF	Current limit reference PWM output.
14	GOK	Intelli-Fuse fault status input. When the Intelli-Fuse detects a MOSFET short, short-circuit, or over-temperature condition, GOK is pulled low.
15	ON	Intelli-Fuse power MOSFET on/off control.
16	EN	Enable. Logic input from the system to turn on the E-fuse device. This can be delayed by a programmable amount of time.
17	D_OC	Open-drain output. When the current is 85% of the CLREF limit, D_OC asserts low to indicate that the current is more than 85% of the CLREF current limit.
22	ALERT#	PMBus alert. ALERT# is active low.
23	SCL	PMBus clock.
24	SDA	PMBus data.
28	GPIO	Open-drain general purpose. GPIO can be programmed to output a fault signal.
29	PG	Open-drain indicator. PG indicates to the system that the E-fuse voltage is within the programmed level.
30	ADDR	Address. Connect a resistor divider from VCC to set the PMBus address.
31	VCC	3 - 3.3V power supply input. Bypass VCC with a 4.7 μ F + 0.1 μ F ceramic capacitor to ground.

OPERATION

The MP5920 is a hot-swap controller designed to sequence MPS Intelli-Fuse devices and provide telemetry and fault detection. The MP5920 allows a circuit board to be removed from or inserted into a live backplane by providing a sequenced turn-on of the Intelli-Fuse devices based on the system enable and input voltage level. A black box recording of the telemetry and fault information to NVM provides detailed diagnostics for faults in the system.

The MP5920 can work with all Intelli-Fuse devices, which feeds back current, voltage, and temperature information to the MP5920. The MP5920 provides telemetry information for the Intelli-Fuse devices via the PMBus. The Intelli-Fuse can be turned on or off through the MP5920 along with a programmable delay to allow for system sequencing.

The MP5920 limits the Intelli-Fuse MP5921 maximum load current by controlling the current-limit reference voltage through CLPWM. For other Intelli-Fuse devices, the IOUT_OC_FAULT_LIMIT can be used to set the current limit below the maximum current limit of the Intelli-Fuse device.

The MP5920 contains a precision analog-digital converter (ADC) to provide accurate telemetry information, Intelli-Fuse on/off control, PMBus interface, and black box capability. The MP5920 can be configured for a single output with a single Intelli-Fuse device or multiple devices in parallel.

MP5920 Reset Sources

The MP5920 has two reset sources: power-on reset and external reset. In power-on reset, the MP5920 is reset when the supply voltage is below the power-on reset threshold (V_{POT}). In external reset, the MP5920 is reset when a low level is present on RESET_N for longer than the minimum pulse length.

Power-On Reset (POR)

A power-on reset (POR) pulse is generated by an on-chip detection circuit. The POR is activated whenever VCC is below the detection level. The POR circuit can be used to trigger the start-up reset and detect a failure in the supply voltage.

A POR circuit ensures that the device is reset from the power-on. Reaching the power-on reset threshold voltage invokes the delay counter, which determines how long the device is kept in reset after VCC rises. The reset signal is activated again without any delay when VCC decreases below the detection level (see Figure 1 and Figure 2).

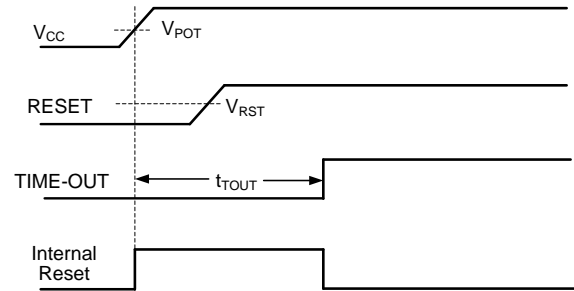

Figure 1: MP5920 Start-Up, RESET_N High before Initial Time-Out

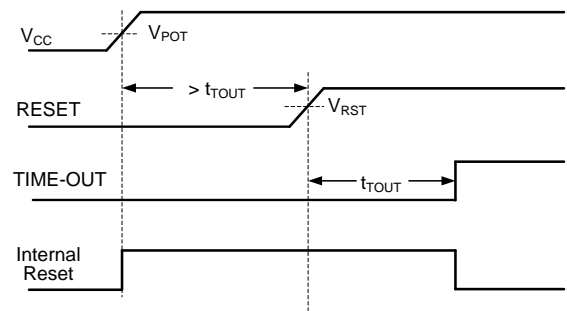
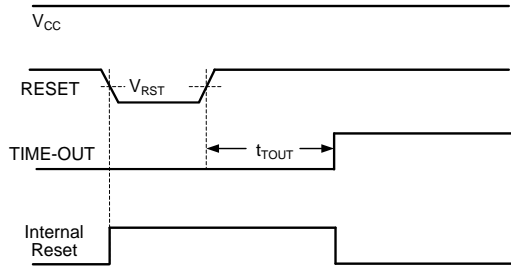

Figure 2: MP5920 Start-Up, RESET_N Extended Eternally

External Reset

An external reset is generated by a low level on RESET_N if it is enabled. Reset pulses longer than the minimum pulse width generate a reset. Shorter pulses are not guaranteed to generate a reset. When the applied signal reaches the reset threshold voltage (V_{RST}) on its positive edge, the delay counter starts the MP5920 after the time-out period (t_{TOUT}) has expired. The external reset is ignored during the power-on start-up count. After the power-on reset, the internal reset is extended only if RESET_N is low when the initial power-on delay count is complete (see Figure 3).

Figure 3: External Reset during Operation

Intelli-Fuse Power MOSFET On/Off Control

ON is connected to ON or EN of the Intelli-Fuse, depending on which device is being interfaced with the MP5920.

When the EN signal is pulled high to enable the Intelli-Fuse, the MP5920 ensures that the POR sequence has occurred, and the input voltage is above the programmed under-voltage lockout (UVLO). If the POR has passed, and V_{IN} is above UVLO, the MP5920 begins the power-on sequence. ON is held low until the T_{ON} delay has passed. Once the T_{ON} delay has occurred, the MP5920 sends a high signal to the Intelli-Fuse. The T_{ON} delay is a programmable value set by register 60h (TON DELAY).

ON can also be controlled by the operation command by setting bit 7. This can be used during operation to turn the device on or off via the PMBus or to reset the E-fuse ON pin state after a non-latching fault event. To do this, clear faults must be sent first to clear fault flags. The operation command is then set to off and back to on. The MP5920 then enables the device using the same T_{ON} delay.

Power-Up Sequence between the MP5920 and Intelli-Fuse

The MP5920 can be powered up by the Intelli-Fuse LDO output or an external power supply. If the MP5920 is powered by the Intelli-Fuse 3.0V LDO output, VCC ramps up with the input voltage. After the MP5920 supply voltage rises above the POR and the time-out period ends, the internal control logic is operational.

For hot-swap applications, the input of the Intelli-Fuse can experience a voltage spike or transient during the hot-plug procedure. This is caused by the parasitic inductance of the input trace and the input capacitor. The internal T_{ON} delay counter delays turn-on until the input voltage has stabilized.

Figure 4 shows the start-up sequence through EN. EN is pulled high after V_{IN} rises. When VCC passes the UVLO threshold and the system initialization finishes, the on signal is driven high immediately once EN is pulled high.

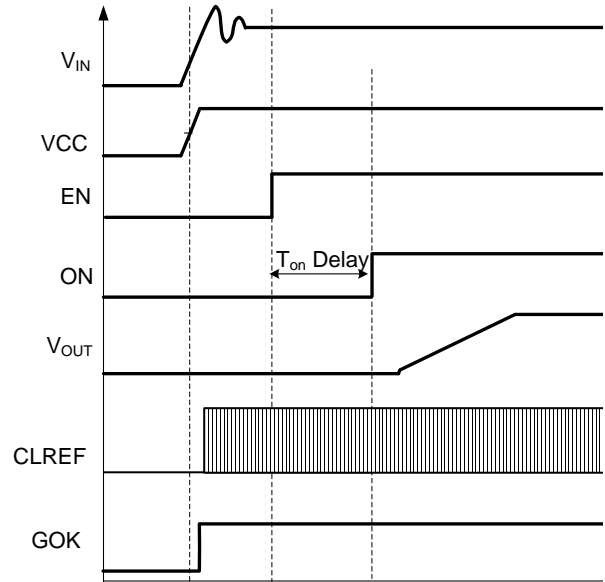
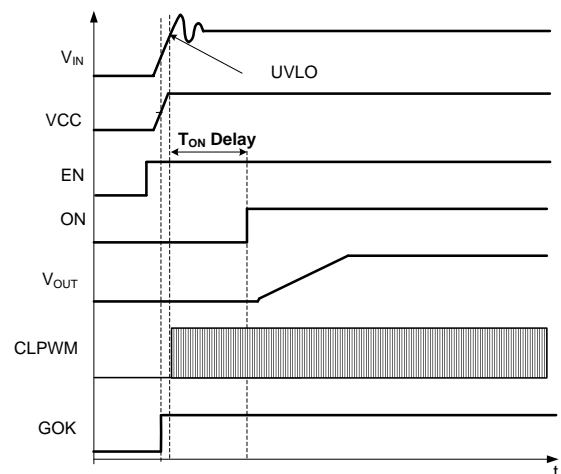

Figure 4: Start-Up Sequences when EN is High after VCC Rises

Figure 5 shows the start-up sequence through the input voltage. EN is pulled high before V_{IN} rises. When VCC passes the UVLO threshold and the system initialization finishes, the on signal is driven high.

Figure 5: Start-Up Sequences when EN is High before VCC Rises

When the high level of ON is detected by the Intelli-Fuse and no fault occurs, the power MOSFET gate voltage is charged up higher by its internal charge pump. Once the Intelli-Fuse power MOSFET V_{GS} voltage reaches its threshold, the power MOSFET is turned on, and the output voltage rises.

Under-Voltage Lockout (UVLO)

UVLO is a programmable level that determines the input voltage level at which the MP5920 turns the MP5921 on or off. When the input voltage rises above the VIN ON (35h) threshold, the MP5920 turns the MP5921 on. When the input voltage falls below the VIN OFF (36h) threshold, the MP5920 turns the MP5921 off.

Current Limit Reference CLREF Output (MP5921)

For the MP5921, a variable current-limit reference voltage (CLREF) can be used to set the over-current protection (OCP) level for an over-current event. This reference voltage is compared to the current sense of the MP5921 to determine whether the limit has been reached. CLREF limiting allows the MP5921 OCP current limit to be adjusted dynamically.

If the CLREF limiting threshold is reached during start-up, the power MOSFET gate voltage of the MP5921 is regulated to hold the MOSFET current constant. The current-limit CLREF can be set higher through the PMBus to allow for higher current limits after the soft start.

For the MP5920, the current-limit reference voltage is achieved by a pulse-width modulation (PWM) output from CLREF. Connect an R-C network to the CLREF output to smooth the CLREF voltage. Generally, 4.7k Ω and 220nF can be chosen to achieve a smooth CLREF value.

The CLREF voltage can be programmed by the PMBus register (0xE7). When the CLREF voltage is exceeded, the MP5921 trips due to the OCP condition and latches off. The power to the MP5921 must be recycled to clear the fault condition.

Over-Current (OC) Fault Limit

The OCP of the E-fuse can also be set by the PMBus command 46h (IOUT OC FAULT LIMIT). This value is compared to the averaged output

current telemetry value. When the current is higher than the programmed limit, the MP5920 disables the MP5921 device(s) (see Figure 6).

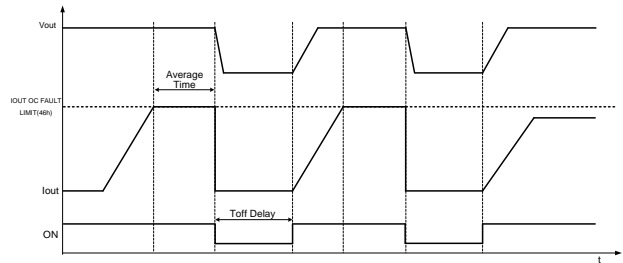

Figure 6: OCP Fault Operation

The number of retries and the time delay between retries is set by IOUT OC FAULT RESPONSE (47h). OCP uses the averaged telemetry values to ensure that the average is updated. The delay time between retries is a multiple of the average time. This ensures that the average has completely cleared the previous current information before trying to restart the MP5921.

This function allows OCP to be set below the max OCP level set by the MP5921 CLREF level. This allows the MP5920 to turn off the MP5921 when currents are above the programmed value and retry. If the current level falls below the OCP value, the MP5920 continues with normal operation. If the MP5921 CLREF level is tripped, the MP5921 latches off, and the power must be cycled to restart the device (see Figure 7).

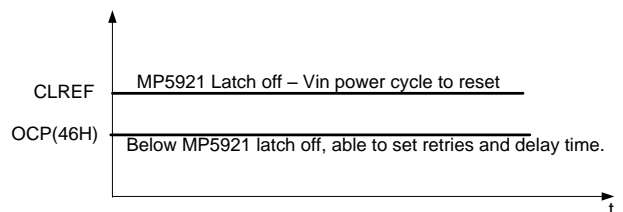

Figure 7: OCP and CLREF Limits

The OCP function uses the averaged output current value and, depending on the average time, can be quite slow to respond. In the instance of large averaging times, it is possible that fast currents rise to the CLREF limit, or shorted output conditions can cause the MP5921 to latch off.

Warning Limits

The MP5920 has programmable warning levels for the output current, temperature, and power. These warnings can be configured as an output on GPIO to alert the system that a warning level has been exceeded. These warnings also have corresponding PMBus bits that can be read to determine which limit has been exceeded.

GOK Report from Intelli-Fuse

GOK is an open-drain, active-low signal from the Intelli-Fuse. GOK is pulled high during normal operation. When a fault has occurred in the Intelli-Fuse, GOK is pulled low. Intelli-Fuse fault events include over-current, short-circuit, Intelli-Fuse power MOSFET short, and thermal shutdown. During the first start-up, if the MP5920 detects a low on the GOK signal, ON is pulled low to turn off the power MOSFET until the signal is released high by the Intelli-Fuse (see Figure 8).

During normal operation, once GOK is pulled low by the Intelli-Fuse, the MP5920 on signal is driven low as well. The release of the GOK fault latch during normal operation can be done by removing fault and recycling VIN.

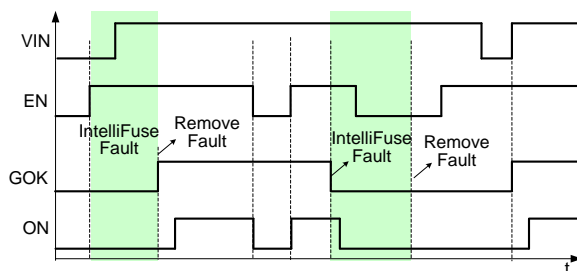

Figure 8: MP5920 Control with GOK Signal

GPIO

GPIO can be programmed to report PWRGD, OCP fault, over-temperature fault, over-temperature warning, and input current warning. GPIO is an open drain and asserts low when the configured setting occurs. GPIO can be used to inform the system that a fault has occurred to disable the power-supply unit (PSU) quickly.

Monitoring the Output Current

IMON provides a voltage proportional to the Intelli-Fuse output current and is set via a resistor to ground. When multiple E-fuse devices are placed in parallel, the equivalent

IMON resistor must be used for accurate current readings (i.e.: $R_{CS}/N_{\text{devices}}$). For the best accuracy, use resistors 1% or better.

There is a possibility of current reading offset due to the offset in the MP5921 IMON output. This can be removed using the IOUT CAL OFFSET (39h) or IOUT AUTO CALIBRATION (E0h). If IOUT AUTO CALIBRATION is used, the MP5920 samples the offset of the MP5921 IMON before enabling the device. This value is used to correct the output current reading. Auto-calibration provides a more accurate current reading by providing the necessary offset for each instance of the MP5921 instead of using a set value. Figure 9 shows the timing of the auto-calibration sampling for IMON offset correction.

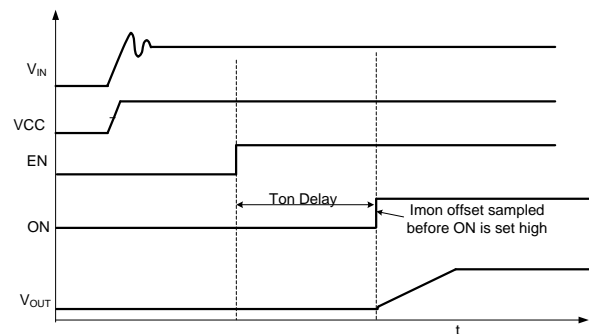

Figure 9: Auto-Calibration Sample

Over-Temperature Protection (OTP)

The MP5920 employs over-temperature warning and over-temperature protection (OTP). These levels can be adjusted to meet the specific needs of the system.

For over-temperature warning, the MP5920 sets the ALERT signal. This signal can also be programmed to be issued on GPIO to be used at a system level for fan control.

The over-temperature limit disables the MP5921 when the temperature reaches the programmed level. The MP5921 is disabled until the temperature level falls to the value programmed in OTP HYSTERESIS (E5h). When the temperature falls below the hysteresis value, the MP5921 is enabled again (see Figure 10).

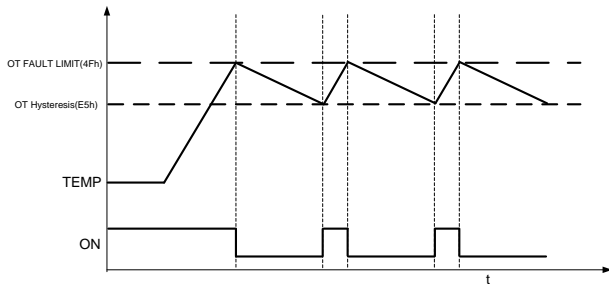

Figure 10: OTP Response

The time between turn-off and turn-on is dependent on the thermal dissipation in the system. The turn-on is completely dependent on the MP5921 temperature falling to the over-temperature (OT) hysteresis level. OT FAULT RESPONSE (50h) determines the number of times the MP5920 attempts to restart the MP5921 due to an OT condition.

Black Box

The black box feature allows the maximum, minimum, and average telemetry values to be stored along with the status registers in the event of a black box trigger. Once the black box write has been initiated, the values cannot be read until the next power cycle to ensure that there is no corruption of data. After the values have been stored, a power cycle of the device is required to allow the stored values to be read. Once the black box password has been written, the corresponding registers can be read via the PMBus.

The black box can be over-written by writing 0 to bit 15 of the black box configuration register. This allows the next black box trigger to save the telemetry to NVM.

Slave Address

ADDR is used to set the PMBus address for the device using an external resistor divider from VCC to GND. The voltage at ADDR during turn-on is sampled and sets the PMBus address. This value is only sampled before controlled E-fuses are enabled. If an external address setting is not needed, the PMBus address can be stored in the NVM and loaded at turn-on.

Table 1 shows the PMBus address for different ADDR voltages.

Table 1: Slave Address vs. ADDR Voltage

V _{ADDR} (V)	Slave Address
0	40h
0.55	41h
0.95	42h
1.35	43h
1.75	44h
2.15	45h
2.55	46h
3	47h

Register E4h allows for configuration of the address for the MP5920. The configuration allows for pin setting of the address or setting via NVM. The register also allows for the extension of the PMBus addressing range. The default is 40 - 47h. The base can be changed from 0 - F, which allows for addressing from 0 - 7h up to F0 - F7h. This allows the device to operate in systems that may have a larger variety of PMBus addresses on a given segment.

PMBUS INTERFACE

PMBus Serial Interface Description

The system management bus (PMBus) is a two-wire, bidirectional, serial interface consisting of a data line (SDA) and a clock line (SCL). The lines are pulled to a bus voltage externally when they are idle. When connecting to the line, a master device generates the SCL signal and device address and arranges the communication sequence. This is based on the principles of I²C operation. The MP5920 interface is a PMBus slave which supports both standard mode (100kHz) and fast mode (400kHz).

PMBus Password

To protect the contents of the PMBus settings, a PMBus password is used. If the PMBus password is not set, all reads from the PMBus registers return 0x0000. The default PMBus password is 0x82C2. Writing 0x82C2 to E1h unlocks protected PMBus registers and allow writes and reads to all PMBus registers.

Start and Stop Conditions

Start and stop are signaled by the master device, which signifies the beginning and end of the PMBus transfer. The start condition is defined as the SDA signal transitioning from high to low while the SCL is high. The stop condition is defined as the SDA signal transitioning from low to high while the SCL is high (see Figure 11).

The master then generates the SCL clocks and transmits the device address and the read/write direction bit (r/w) on the SDA line. Data is transferred in 8-bit bytes by the SDA line. Each byte of data is to be followed by an acknowledge bit.

PMBus Update Sequence

The MP5920 requires a start condition, a valid PMBus address, a register address byte, and a data byte for a single data update. The MP5920 acknowledges the receipt of each byte by pulling the SDA line low during the high period of a single clock pulse. A valid PMBus address selects the MP5920. The MP5920 performs an update on the falling edge of the least significant byte (LSB).

Protocol Usage

All PMBus transactions on the MP5920 are done using defined bus protocols. The following protocols are implemented:

- Send byte with PEC
- Receive byte with PEC
- Write byte with PEC
- Read byte with PEC
- Write word with PEC
- Read word with PEC
- Block read with PEC

PMBus Bus Message Format

In the following charts on page 14 and page 15, the unshaded cells indicate that the bus host is driving the bus actively. The shaded cells indicate that the MP5920 is driving the bus. Refer to the key in Table 2.

Table 2: Protocol Usage Key

S	Start condition
Sr	Repeated start condition
P	Stop condition
R	Read bit
\overline{W}	Write bit
A	Acknowledge bit (0)
\overline{A}	Acknowledge bit (1)

“A” represents the acknowledge (ACK) bit. The ACK bit is active low (logic 0) typically if the transmitted byte is received successfully by a device. However, when the receiving device is the bus master, the acknowledge bit for the last byte read is a logic 1, indicated by “ \overline{A} ”.

Packet Error Checking (PEC)

The MP5920 PMBus interface supports the use of the packet error checking (PEC) byte. The PEC byte is transmitted by the MP5920 during a read transaction or sent by the bus host to the MP5920 during a write transaction. The PEC byte is used by the bus host or the MP5920 to detect errors during a bus transaction, depending on whether the transaction is a read or a write. If the host determines that the PEC byte read during a read transaction is incorrect, it can decide to repeat the read if necessary. If the MP5920 determines that the PEC byte sent during a write transaction is incorrect, it ignores the command and sets a status flag. Within a group command, the host can choose to send or not send a PEC byte as part of the message to the MP5920.

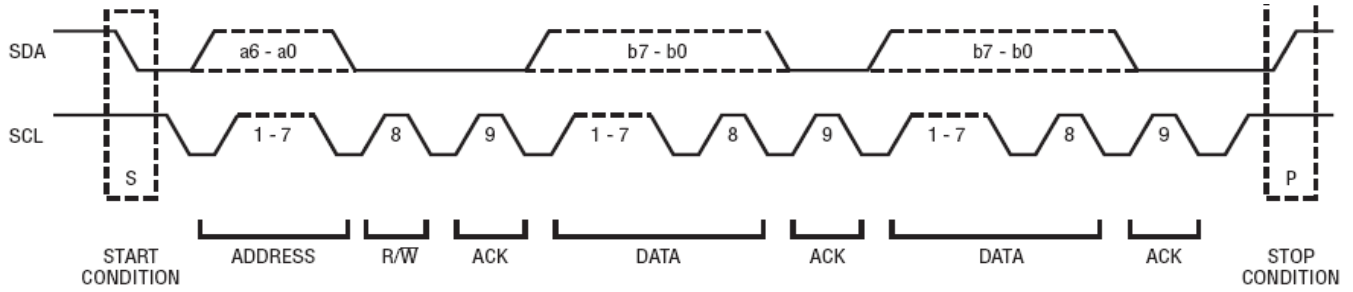
Figure 11: Data Transfer over PMBus
Send Byte and Send Byte with PEC

1	7	1	1	8	1	1
S	Slave Address	Wr	A	Data Byte	A	P

1	7	1	1	8	1	8	1	1
S	Slave Address	Wr	A	Data Byte	A	PEC	A	P

Receive Byte and Receive Byte with PEC

1	7	1	1	8	1	1
S	Slave Address	Rd	A	Data Byte	A	P

1	7	1	1	8	1	8	1	1
S	Slave Address	Rd	A	Data Byte	A	PEC	A	P

Write Byte and Write Byte with PEC

1	7	1	1	8	1	8	1	1
S	Slave Address	Wr	A	Command Code	A	Data Byte	A	P

1	7	1	1	8	1	8	1	8	1	1
S	Slave Address	Wr	A	Command Code	A	Data Byte	A	PEC	A	P

Write Word and Write Word with PEC

1	7	1	1	8	1	8	1	8	1	1
S	Slave Address	Wr	A	Command Code	A	Data Byte Low	A	Data Byte High	A	P

1	7	1	1	8	1	8	1	8	1	8	1	1
S	Slave Address	Wr	A	Command Code	A	Data Byte Low	A	Data Byte High	A	PEC	A	P

Read Byte and Read Byte with PEC

1	7	1	1	8	1	1	7	1	1	8	1	1
S	Slave Address	Wr	A	Command Code	A	S	Slave Address	Rd	A	Data Byte	A	P

1	7	1	1	8	1	1	7	1	1	8	1	8	1	1
S	Slave Address	Wr	A	Command Code	A	S	Slave Address	Rd	A	Data Byte	A	PEC	A	P

Read Word and Read Word with PEC

1	7	1	1	8	1	1	7	1	1	8	1
S	Slave Address	Wr	A	Command Code	A	S	Slave Address	Rd	A	Data Byte Low	A

8	1	1
Data Byte High	A	P

1	7	1	1	8	1	1	7	1	1	8	1
S	Slave Address	Wr	A	Command Code	A	S	Slave Address	Rd	A	Data Byte Low	A

8	1	8	1	1
Data Byte High	A	PEC	A	P

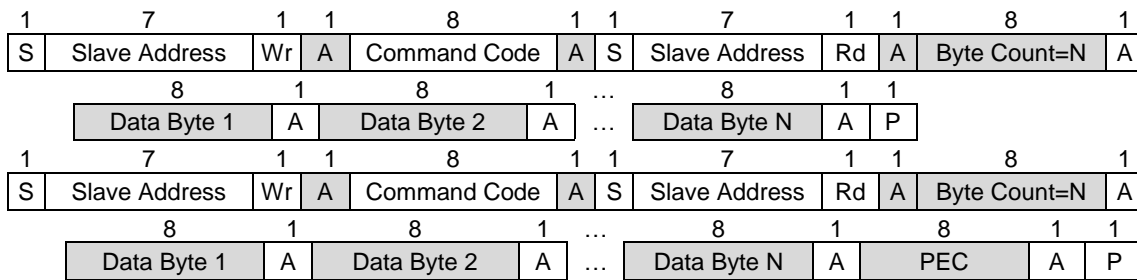
Block Read with PEC

ADC Sampling

The MP5920 features an integrated 12-bit ADC that measures the IMON sense current, the input voltage through VINSEN, the output voltage by VOSEN, and the temperature from VTEMP accurately. The MP5920 reports the measured output current, input voltage, output voltage, and temperature. The measured input voltage and current being delivered to the load are multiplied together to produce a power value that can be read back. Each power value is also added to an energy accumulator that can be read back to allow an external device to calculate the energy consumption of the load.

The telemetry values can be averaged over a programmed period of time. This time period is set via the 0xE2 register. The selected value for averaging is applied to all parameters (V_{IN} , V_{OUT} , I_{OUT} , temp, P_{OUT}). Time current sense and input voltage measurements are taken, and a power calculation is performed, multiplying the two measurements together. This can be read from the device using the READ_POUT command, returning the input power.

At the same time, the calculated power value is added to a power accumulator register that may increment a rollover counter if the value exceeds the maximum accumulator value. The power accumulator register also increments a power sample counter. The power accumulator and power sample counter are read using the same READ_EIN command (86h) to ensure that the accumulated value and sample count are from the same point in time. The bus host reading the data assigns a time stamp when the data is read. By calculating the time difference between consecutive uses of READ_EIN and determining the delta in the power consumed, it is possible for the host to determine the total energy consumed over that period.

PMBus Direct Format Conversions

The MP5920 uses the PMBus direct format to represent real-world quantities, such as voltage, current, and power values. A direct format number takes the form of a 2-byte, twos complement, binary integer value.

It is possible to convert between direct format values and real-world quantities using the following equations.

Convert from real-world quantities to PMBus direct values with Equation (1):

$$Y = (mX + b) \times 10^R \quad (1)$$

Convert PMBus direct format values to real-world values with Equation (2):

$$X = \frac{1}{m} (Y \times 10^{-R} - b) \quad (2)$$

Where Y is the value in PMBus direct format; X is the real-world value; m is the slope coefficient, a 2-byte, or twos complement integer; b is the offset, a 2-byte, or twos complement integer; and R is a scaling exponent, a 1-byte, or twos complement integer.

The same equations can be used for voltage, current, power, and temperature conversions, the only difference being the values of the m, b, and R coefficients.

REGISTER DISCRIPTION

Note that the number of data bytes does not include PEC bytes, if used, nor does it include the byte count byte of block read transactions.

Name	Code	Type	Bytes	Default Value	Data Formats	PWD Protect
PAGE	0x00	r/w byte	1	0x00		
OPERATION	0x01	r/w byte	1	0x80		
CLEAR_FAULTS	0x03	Send byte	0	Not applicable	-	
STORE_USER_ALL	0X15	Send byte	0			
CAPABILITY	0x19	Read byte	1	0xD0	-	
VIN_ON	0X35	r/w word	2	Set by Config	Direct	PMBUS
VIN_OFF	0X36	r/w word	2	Set by Config	Direct	PMBUS
IOUT_CAL_OFFSET	0X39	r/w word	2	Set by Config	Direct	PMBUS
IOUT_OC_FAULT_LIMIT	0X46	r/w word	2	Set by Config	Direct	PMBUS
IOUT_OC_FAULT_RESPONSE	0X47	r/w byte	1	Set by Config	Direct	PMBUS
OT_FAULT_LIMIT	0X4F	r/w word	2	Set by Config	Direct	PMBUS
OT_FAULT_RESPONSE	0X50	r/w word	2	Set by Config	Direct	PMBUS
OT_WARN_LIMIT	0X51	r/w word	2	Set by Config	Direct	PMBUS
VIN_OV_FAULT_LIMIT	0X55	r/w word	2	Set by Config	Direct	PMBUS
IIN_OC_WARN_LIMIT	0X5D	r/w word	2	Set by Config	Direct	PMBUS
POWER_GOOD_ON	0X5E	r/w word	2	Set by Config	Direct	PMBUS
POWER_GOOD_OFF	0X5F	r/w word	2	Set by Config	Direct	PMBUS
TON_DELAY	0X60	r/w word	2	Set by Config	Direct	PMBUS
POUT_OP_WARN_LIMIT	0X6A	r/w word	2	Set by Config	Direct	PMBUS
STATUS_WORD	0x79	Read word	2	0x0000	-	
STATUS_IOUT	0X7B	Read byte	1	0x00		
STATUS_INPUT	0X7C	Read byte	1	0x00		
STATUS_TEMP	0X7D	Read byte	1	0x00		
READ_EIN	0x86	Block read	6	0x000000000000	Direct	
READ_VIN	0x88	Read word	2	0x0000	Direct	
READ_VOUT	0x8B	Read word	2	0x0000	Direct	
READ_IOUT	0x8C	Read word	2	0x0000	Direct	
READ_TEMPERATURE	0x8D	Read word	2	0x0000	Direct	
READ_POUT	0x96	Read word	2	0x0000	Direct	
PMBUS_REVISION	0x98	Read byte	1	0x33	-	
MFR_ID	0x99	Block read	3	ASCII "MPS"	-	
MFR_MODEL	0x9A	Block read	6	ASCII "MP5920"	-	
MFR_REVISION	0x9B	Block read	1	0x30	-	
MIN_VIN	0XA0	Read word	2	Set by Config	Direct	
MAX_VIN	0XA1	Read word	2	Set by Config	Direct	
MIN_VOUT	0XA4	Read word	2	Set by Config	Direct	
MAX_VOUT	0XA5	Read word	2	Set by Config	Direct	
MAX_IOUT	0XA6	Read word	2	Set by Config	Direct	
MAX_POUT	0XA7	Read word	2	Set by Config	Direct	
MAX_TAMBIENT	0XA8	Read word	2	Set by Config	Direct	
USER_DATA_00	0XB0	r/w word	2	0x0000		PMBUS
USER_DATA_01	0XB1	r/w word	2	0x0000		PMBUS
USER_DATA_02	0XB2	r/w word	2	0x0000		PMBUS
USER_DATA_03	0XB3	r/w word	2	0x0000		PMBUS
USER_DATA_04	0XB4	r/w word	2	0x0000		PMBUS
USER_DATA_05	0XB5	r/w word	2	0x0000		PMBUS
USER_DATA_06	0XB6	r/w word	2	0x0000		PMBUS
USER_DATA_07	0XB7	r/w word	2	0x0000		PMBUS
USER_DATA_08	0XB8	r/w word	2	0x0000		PMBUS
USER_DATA_09	0XB9	r/w word	2	0x0000		PMBUS
USER_DATA_10	0XBA	r/w word	2	0x0000		PMBUS

REGISTER DISCRIPTION (continued)

Name	Code	Type	Bytes	Default Value	Data Formats	PWD Protect
IOUT AUTO CALIBRATION	0xE0	r/w byte	1	Set by Config		PMBUS
PMBUS_PWD	0xE1	r/w word	2	0x0000		
TELEMETRY_AVERAGE	0xE2	r/w word	2	Set by Config		PMBUS
ADDRESS CONFIG	0XE4	r/w word	2	Set by Config		PMBUS
OTP HYSTERESIS	0XE5	r/w word	2	Set by Config		PMBUS
GPIO CONFIG	0XE6	r/w word	2	Set by Config		PMBUS
CLREF DUTY CYCLE	0XE7	r/w byte	1	Set by Config		PMBUS
BLACK BOX PWD	0XF0	r/w word	2			
BLACK BOX VIN	0XF1	Block read	6		DIRECT	BLACK BOX
BLACK BOX VOUT AVG	0XF2	Block read	8		DIRECT	BLACK BOX
BLACK BOX VOUT MAX	0XF4	Block read	8		DIRECT	BLACK BOX
BLACK BOX FAULTS	0XF6	Block read	8			BLACK BOX
BLACK BOX STATUS	0XF7	Block read	8			BLACK BOX
BLACK BOX CONFIG	0XFC	r/w word	2			BLACK BOX
NVM PWD	0XFD	r/w word	2			

PMBUS COMMANDS

PAGE (00h)

This PAGE command provides the ability to configure, control, and monitor through only one physical address.

Bits	Name	Behavior	Default Set	Description
[7:2]	Reserved	r/w	000000	
[1:0]	PAGE	r/w	0	00: Page0 register Main rail E-fuse is selected.

OPERATION (01h)

Bits	Name	Behavior	Default Set	Description
[7]	On/off state	r/w	1	0: output is off 1: output is on
[6:0]	Not used	r/w	0000000	

CLEAR_FAULTS (03h)

The CLEAR_FAULTS command is used to reset all stored warning and fault flags in the Page0 registers. If a fault or warning condition still exists when the CLEAR_FAULTS command is issued, the ALERT# signal may not clear or re-asserts almost immediately. Issuing a CLEAR_FAULTS command will not cause the MOSFET to switch back on in the event of a fault turn-off. This command uses the PMBus send byte protocol.

STORE_USER_ALL (15h)

The STORE_USER_ALL command is used to save the values in the operational registers to the NVM of the MP5920. Before the data can be saved to the non-volatile memory (NVM), the NVM password must be sent to allow access to the NVM. The NVM password must be written to 0xFD before writes can occur when STORE_USER_ALL is used.

CAPABILITY (19h)

The CAPABILITY command returns information about the PMBus functions supported by the MP5920. This command is read with the PMBus read byte protocol.

CAPABILITY								
Format	Unsigned binary							
Bit	7	6	5	4	3	2	1	0
Access	r	r	r	r	r	r	r	r
Function	PEC	Max. bus speed		Alert	x	x	x	x
Default value	1	0	1	1	0	0	0	0
PEC supported, max speed 400kHz, supports SMBAlert								

VIN_ON (35h)

VIN_ON sets the voltage at which the MP5920 allows the E-fuse device to be enabled. If it is desired that the E-fuse cannot be enabled until 10V, this value can be programmed into VIN_ON, and the MP5920 prevents the E-fuse from being enabled until V_{IN} is higher than the programmed value.

VIN_ON																
Command	Direct															
Format	Direct															
Bit	15	14	13	12	11	10	9	8	7	6	5	4	3	2	1	0
Access	r/w	r/w	r/w	r/w	r/w	r/w	r/w	r/w	r/w	r/w	r/w	r/w	r/w	r/w	r/w	r/w
Function																
Default value	0	0	0	0	0	0	0	0	0	0	0	0	0	0	0	0

VIN OFF (36h)

VIN OFF sets the voltage at which the MP5920 turns off the E-fuse devices. When the V_{IN} values are below the programmed value, the MP5920 disables the E-fuse.

Command	VIN OFF															
Format	Direct															
Bit	15	14	13	12	11	10	9	8	7	6	5	4	3	2	1	0
Access	r/w	r/w	r/w	r/w	r/w	r/w	r/w	r/w	r/w	r/w	r/w	r/w	r/w	r/w	r/w	r/w
Function																
Default value	0	0	0	0	0	0	0	0	0	0	0	0	0	0	0	0

IOUT CAL OFFSET (39h)

IOUT CAL OFFSET can be used to remove any offset from the current reading of the E-fuse. This register is signed and can adjust for positive and negative offsets. If auto-calibration is used, the value stored in IOUT CAL OFFSET is not used.

Command	IOUT CAL OFFSET															
Format	Direct															
Bit	15	14	13	12	11	10	9	8	7	6	5	4	3	2	1	0
Access	r/w	r/w	r/w	r/w	r/w	r/w	r/w	r/w	r/w	r/w	r/w	r/w	r/w	r/w	r/w	r/w
Function																
Default value	0	0	0	0	0	0	0	0	0	0	0	0	0	0	0	0

IOUT OC FAULT LIMIT (46h)

When the output current is above the programmed value, the E-fuse device is disabled. This provides the ability to set a current limit lower than the E-fuse max current limit. The current limit value is based on the telemetry averaging setting.

Command	IOUT OC FAULT LIMIT															
Format	Direct															
Bit	15	14	13	12	11	10	9	8	7	6	5	4	3	2	1	0
Access	r/w	r/w	r/w	r/w	r/w	r/w	r/w	r/w	r/w	r/w	r/w	r/w	r/w	r/w	r/w	r/w
Function																
Default value	0	0	0	0	0	0	0	0	0	0	0	0	0	0	0	0

IOUT OC FAULT RESPONSE (47h)

IOUT OC FAULT RESPONSE determines the number of retries and the delay time for IOUT OC FAULT LIMIT (46h).

Command	IOUT OC FAULT RESPONSE									
Format	Direct									
Bit	7	6	5	4	3	2	1	0		
Access	r/w	r/w	r/w	r/w	r/w	r/w	r/w	r/w		
Function	Response			Retry setting			Delay time			
Default value	1	1	1	1	1	1	1	1	1	

Bits	Name	Description
[7:6]	Response	Always 11.
[5:3]	Retry Setting	000: no retries 001 - 110: sets number of retries from 1-6 111: continuous retries
[2:0]	Delay Time	Sets the delay time for retry, value is a multiple of the telemetry averaging time. Min value is 1x the average time with a max of 8x.

OT FAULT LIMIT (4Fh)

OT FAULT LIMIT sets the temperature value at which the MP5920 disables the E-fuse device. This is only used with MP5921 E-fuse devices.

Command	OT FAULT LIMIT															
Format	Direct															
Bit	15	14	13	12	11	10	9	8	7	6	5	4	3	2	1	0
Access	r/w	r/w	r/w	r/w	r/w	r/w	r/w	r/w	r/w	r/w	r/w	r/w	r/w	r/w	r/w	r/w
Function																
Default value	0	0	0	0	0	0	0	0	0	0	0	0	0	0	0	0

OT FAULT RESPONSE (50h)

OT FAULT RESPONSE sets the number of retries and the time between retries for the OT fault response.

Command	OT FAULT RESPONSE								
Format	Direct								
Bit	7	6	5	4	3	2	1	0	
Access	r/w	r/w	r/w	r/w	r/w	r/w	r/w	r/w	
Function	Response			Retry setting			Delay time		
Default value	1	1	1	1	1	1	1	1	1

Bits	Name	Description
[7:6]	Response	Always 10.
[5:3]	Retry Setting	000: no retries 001 - 110: sets number of retries from 1-6 111: continuous retries
[2:0]	Delay Time	Delay time is not used. The OTP HYSTERESIS (E5h) command determines when the device is allowed to turn back on.

OT WARN LIMIT (51h)

When OT WARN LIMIT is exceeded, ALERT# on the PMBus is asserted.

Command	OT WARN LIMIT															
Format	Direct															
Bit	15	14	13	12	11	10	9	8	7	6	5	4	3	2	1	0
Access	r/w	r/w	r/w	r/w	r/w	r/w	r/w	r/w	r/w	r/w	r/w	r/w	r/w	r/w	r/w	r/w
Function																
Default value	0	0	0	0	0	0	0	0	0	0	0	0	0	0	0	0

VIN OV FAULT LIMIT (55h)

When OV FAULT LIMIT is exceeded, ALERT# on the PMBus is asserted, and the E-fuse is disabled.

Command	VIN OV FAULT LIMIT															
Format	Direct															
Bit	15	14	13	12	11	10	9	8	7	6	5	4	3	2	1	0
Access	r/w	r/w	r/w	r/w	r/w	r/w	r/w	r/w	r/w	r/w	r/w	r/w	r/w	r/w	r/w	r/w
Function																
Default value	0	0	0	0	0	0	0	0	0	0	0	0	0	0	0	0

IIN OC WARN LIMIT (5Dh)

IIN OC WARN LIMIT sets the warning current limit. When the value is exceeded, ALERT# is asserted. GPIO can be configured to assert when exceeded.

Command	IIN OC WARN LIMIT															
Format	Direct															
Bit	15	14	13	12	11	10	9	8	7	6	5	4	3	2	1	0
Access	r/w	r/w	r/w	r/w	r/w	r/w	r/w	r/w	r/w	r/w	r/w	r/w	r/w	r/w	r/w	r/w
Function																
Default value	0	0	0	0	0	0	0	0	0	0	0	0	0	0	0	0

POWER GOOD ON (5Eh)

POWER GOOD ON sets the rising output voltage level at which PG is allowed to go high.

Command	POWER GOOD ON															
Format	Direct															
Bit	15	14	13	12	11	10	9	8	7	6	5	4	3	2	1	0
Access	r/w	r/w	r/w	r/w	r/w	r/w	r/w	r/w	r/w	r/w	r/w	r/w	r/w	r/w	r/w	r/w
Function																
Default value	0	0	0	0	0	0	0	0	0	0	0	0	0	0	0	0

POWER GOOD OFF (5Fh)

POWER GOOD OFF sets the output voltage level at which PG is pulled low.

Command	POWER GOOD OFF															
Format	Direct															
Bit	15	14	13	12	11	10	9	8	7	6	5	4	3	2	1	0
Access	r/w	r/w	r/w	r/w	r/w	r/w	r/w	r/w	r/w	r/w	r/w	r/w	r/w	r/w	r/w	r/w
Function																
Default value	0	0	0	0	0	0	0	0	0	0	0	0	0	0	0	0

TON DELAY (60h)

TON DELAY is used to set the delay time from enable high on EN to the time ON/PD is issued. The min delay time is 1ms.

Command	TON DELAY															
Format	Direct															
Bit	15	14	13	12	11	10	9	8	7	6	5	4	3	2	1	0
Access	r/w	r/w	r/w	r/w	r/w	r/w	r/w	r/w	r/w	r/w	r/w	r/w	r/w	r/w	r/w	r/w
Function	Lsb = 200µs															
Default value	0	0	0	0	0	0	0	0	0	0	0	0	0	0	0	0

POUT OP WARN LIMIT (6Ah)

POUT OP WARN LIMIT sets the output power warning level. GPIO can be configured to assert when the output power exceeds the warning level.

Command	POUT OP WARN LIMIT															
Format	Direct															
Bit	15	14	13	12	11	10	9	8	7	6	5	4	3	2	1	0
Access	r/w	r/w	r/w	r/w	r/w	r/w	r/w	r/w	r/w	r/w	r/w	r/w	r/w	r/w	r/w	r/w
Function																
Default value	0	0	0	0	0	0	0	0	0	0	0	0	0	0	0	0

STATUS WORD (79h)

STATUS WORD returns the value of a number of flags indicating the state of the MP5920. To clear bits in this register, the underlying fault should be removed and a CLEAR_FAULTS command issued.

Bits	Name	Behavior	Default Set	Description
[15]	Reserved		0000000	Always read as 0
[14]	IOUT_STATUS	Latched	0	0: no fault 1: fault has occurred
[13]	VIN_STATUS		0	0: no fault 1: fault has occurred
[12]	BAD EFUSE	Live	0	0: no fault 1: fault has occurred, GOK pulled low
[11]	POWER_GOOD#		0	0: no fault 1: fault has occurred, PG not asserted
[10:7]	Reserved	Latched	0	Always reads 0000
[6]	HOTSWAP_OFF		00	0: no fault 1: hot-swap has been disabled
[5]	RESERVED	Latched	0	Always reads 0
[4]	DOC_WARNING		0	0: no fault 1: DOC has been asserted
[3]	VIN_UV			0: no fault 1: fault has occurred, input voltage below UVLO
[2]	TEMP_STATUS			0: no fault 1: fault has occurred
[1]	CUMM_ERROR			
[0]	NONE_OF_THE_ABOVE			

STATUS IOUT (7Bh)

STATUS_IOUT returns the value of a number of flags indicating the state of the MP5920. To clear the bits in this register, the underlying fault should be removed and a CLEAR_FAULTS command issued.

Bits	Name	Behavior	Default	Description
[7]	IOUT OC FAULT	Latched	0	0: no fault has occurred 1: fault has occurred
[6]	Reserved			
[5]	IOUT OC WARNING	Latched	0	0: no fault has occurred 1: fault has occurred
[4]	Reserved			
[3]	DOC Assert	Live	0	0: no fault has occurred 1: fault has occurred
[2]	Reserved			
[1]	Reserved			
[0]	POUT OP WARNING	Live	0	0: no fault has occurred 1: fault has occurred

STATUS INPUT (7Ch)

STATUS_INPUT returns the value of a number of flags indicating the state of the MP5920. To clear the bits in this register, the underlying fault should be removed and a CLEAR_FAULTS command issued.

Bits	Name	Behavior	Default	Description
[7]	VIN OV FAULT	Live	0	0: no fault has occurred 1: fault has occurred
[6]				
[5]				
[4]	VIN UV FAULT	Live	0	0: no fault has occurred 1: fault has occurred
[3]				
[2]				
[1]	IIN OC WARN	Latched	0	0: no fault has occurred 1: fault has occurred
[0]	PIN OP WARN	Latched	0	0: no fault has occurred 1: fault has occurred

READ_EIN (86h) Block Read

READ_EIN returns the 16 bits of the energy accumulator, the eight bits of the rollover counter, and the 24 bits of the sample counter.

Byte	Byte Name		Value	Description
[0]	Low byte	Energy Accumulator	0x0000	Energy accumulator value in direct format. Byte 2 is the high byte, and Byte 1 is the low byte. Internally, the energy accumulator is a 16-bit value.
[1]	High byte			
[2]	Rollover Count		0x00	Number of times that the energy count has rolled over from 0x7FFF to 0x0000. This is a straight 8-bit binary value.
[3]	Low byte	Sample Count	0x000000	Total number of pin samples acquired and accumulated in the energy count accumulator. Byte 6 is the high byte, Byte 5 is the middle byte, and Byte 4 is the low byte. This is a straight 24-bit binary value.
[4]	Middle byte			
[5]	High byte			

This is a preferred command for supporting input power monitoring. This command provides a more flexible method for power sensing so that the system can get faster or slower power data depending on how fast it polls the device. Below are more details on the command and reported values.

- Low/high byte power accumulator format: Direct format. Reports two's complement signed value in watts. The power accumulator sums samples of the instantaneous input power continuously. Its maximum positive value is 0x7FFF.
- Accumulator rollover counter: 1-byte non-signed value counting the number of times the 2-byte power accumulator value changes from 0x7FFF to 0x0000.
- 3-byte non-signed value for sample counter.
- The sample counter and power accumulator values must be coherent so that at any time the system accesses the READ_EIN command, the device returns a sample count and power accumulator value that have the same time reference.
- Maximum sampling period of about 200ms. Minimum rollover of the sample counter and power accumulator of about five seconds when monitoring 1000W.
- Default of continuous sampling. This means that whenever the MP5920 has an input voltage, it is sampling the input voltage and current.
- Reset: The READ_EIN power accumulator, rollover counter, and sample count should keep the latest value when the input voltage is present. The values shall be maintained if the MP5920 has turned off the internal MOSFET. The values shall be reset to 00 only if the input voltage is lost.

The list below shows how to set the registers values.

- Each time a power calculation is done, the 12-bit power value is added to a 16-bit energy accumulator register. Each time this energy accumulator register rolls over from 0x7FFF to 0x0000, an 8-bit rollover counter is incremented. The rollover counter is straight binary with a maximum value of 0xFF before it rolls over. If Rollover Count rolls over from 0xFF to 0x00, it indicates that the energy accumulator rolls over from 0x7FFF to 0x0000. The two registers are accumulated from 0 at the same time.
- A 24-bit straight binary power sample counter is also incremented by 1 each time a power value is calculated and added to the energy accumulator.
- A bus host can read these values, and by calculating the delta in the energy accumulated, the delta in the number of samples, and the time delta since the last read, the host can calculate the average power since the last read, as well as the energy consumed since then.
- The time delta is calculated by the bus host based on when it sends its commands to read from the device and is not provided by the MP5920.

- To avoid loss of data, the bus host must read at a rate that ensures that the rollover counter does not wrap around more than once. If the counter does wrap around, the next value read for power input (PIN) is less than the previous one.

To convert the data obtained with the READ_EIN command to average power, first convert the accumulator and rollover count to an unsigned integer with Equation (3):

$$\text{Accumulator}_{23} = (\text{Rollover_count} \ll 15) + \text{Accumulator} \quad (3)$$

Overflow detection and handling should be done on the 23 bits of the accumulator data and the sample count. Data from the previous calculation should be saved and used to get the unscaled average power using Equation (4):

$$\frac{\text{Accumulator}_{23}[n] - \text{Accumulator}_{23}[n-1]}{\text{Sample_count}[n] - \text{Sample_count}[n-1]} \quad (4)$$

Where Accumulator₂₃[n] is the overflow-corrected 23-bit accumulator data from this read, Sample_count [n] is the sample count data from this read, Accumulator₂₃[n-1] is the overflow-corrected 23-bit accumulator data from the previous read, and Sample_count [n-1] is the sample count data from the previous read.

READ_VIN (88h)

The READ_VIN command returns the 12-bit measured value of the input voltage from the VINSEN measurement after averaging.

Command	READ_VIN															
Format	Direct															
Bit	15	14	13	12	11	10	9	8	7	6	5	4	3	2	1	0
Access	r	r	r	r	r	r	r	r	r	r	r	r	r	r	r	r
Function																
Default value	0	0	0	0	0	0	0	0	0	0	0	0	0	0	0	0

READ_VOUT (8Bh)

The READ_VOUT command returns the 12-bit measured value of the output voltage from the VOSEN measurement after averaging.

Command	READ_VOUT															
Format	Direct															
Bit	15	14	13	12	11	10	9	8	7	6	5	4	3	2	1	0
Access	r	r	r	r	r	r	r	r	r	r	r	r	r	r	r	r
Function																
Default value	0	0	0	0	0	0	0	0	0	0	0	0	0	0	0	0

READ_IOUT (8Ch)

The READ_IOUT command returns the 12-bit measured value of the output current derived from the IMON voltage measurement after averaging.

Command	READ_IOUT															
Format	Direct															
Bit	15	14	13	12	11	10	9	8	7	6	5	4	3	2	1	0
Access	r	r	r	r	r	r	r	r	r	r	r	r	r	r	r	r
Function																
Default value	0	0	0	0	0	0	0	0	0	0	0	0	0	0	0	0

READ_TEMPERATURE (8Dh)

The READ_TEMPERATURE command returns the temperature from TEMP measurement after averaging. This value is also used internally for the over-temperature fault and warning detection.

Command	READ_TEMPERATURE															
Format	Direct															
Bit	15	14	13	12	11	10	9	8	7	6	5	4	3	2	1	0
Access	r	r	r	r	r	r	r	r	r	r	r	r	r	r	r	r
Function																
Default value	0	0	0	0	0	0	0	0	0	0	0	0	0	0	0	0

READ_POUT (96h)

The READ_POUT command returns the internal input power calculation, using VOUT x IOUT, after averaging.

Command	READ_POUT															
Format	Direct															
Bit	15	14	13	12	11	10	9	8	7	6	5	4	3	2	1	0
Access	r	r	r	r	r	r	r	r	r	r	r	r	r	r	r	r
Function																
Default value	0	0	0	0	0	0	0	0	0	0	0	0	0	0	0	0

PMBUS_REVISION (98h)

The PMBUS_REVISION command returns the PMBus protocol revision the MP5920 used. Access to this command should use the read byte protocol. Bit [7:4] indicates the PMBus revision of specification Part I, to which the device is compliant. Bit [3:0] indicates the revision of specification Part II, to which the device is compliant.

Command	PMBUS_REVISION							
Format	Unsigned binary							
Bit	7	6	5	4	3	2	1	0
Access	r	r	r	r	r	r	r	r
Default value	0	0	1	0	0	0	1	0

MFR_ID (99h)

The MFR_ID command returns the company identification.

Byte	Byte Name	Value	Description
0	Character 1	0x4D or "M"	Always reads as 0x4D.
1	Character 2	0x50 or "P"	Always reads as 0x50.
2	Character 3	0x53 or "S"	Always reads as 0x53.

MFR_MODEL (9Ah)

The MFR_MODEL command returns the part name.

Byte	Byte Name	Value	Description
0	Character 1	0x4D or "M"	Always reads as 0x4D.
1	Character 2	0x50 or "P"	Always reads as 0x50.
2	Character 3	0x35 or "5"	Always reads as 0x35.
3	Character 4	0x30 or "9"	Always reads as 0x39.
4	Character 5	0x32 or "2"	Always reads as 0x32.
5	Character 6	0x30 or "0"	Always reads as 0x30.

The default value is 0x30 32 39 35 50 4D.

MFR_REVISION (9Bh)

MFR_REVISION returns the part revision.

Byte	Byte Name	Value	Description
1	Character 1	0x30 or "0"	Always reads as 0x30.

MFR VIN MIN (A0h)

MFR VIN MIN provides the minimum input voltage. The value is reset when read.

Command	MFR VIN MIN															
Format	Direct															
Bit	15	14	13	12	11	10	9	8	7	6	5	4	3	2	1	0
Access	r	r	r	r	r	r	r	r	r	r	r	r	r	r	r	r
Function																
Default value	0	0	0	0	0	0	0	0	0	0	0	0	0	0	0	0

MFR VIN MAX (A1h)

MFR VIN MAX provides the maximum input voltage. The value is reset when read.

Command	MFR VIN MAX															
Format	Direct															
Bit	15	14	13	12	11	10	9	8	7	6	5	4	3	2	1	0
Access	r	r	r	r	r	r	r	r	r	r	r	r	r	r	r	r
Function																
Default value	0	0	0	0	0	0	0	0	0	0	0	0	0	0	0	0

MFR VOUT MIN (A4h)

MFR VOUT MIN provides the minimum output voltage. The value is reset when read.

Command	MFR VOUT MIN															
Format	Direct															
Bit	15	14	13	12	11	10	9	8	7	6	5	4	3	2	1	0
Access	r	r	r	r	r	r	r	r	r	r	r	r	r	r	r	r
Function																
Default value	0	0	0	0	0	0	0	0	0	0	0	0	0	0	0	0

MFR VOUT MAX (A5h)

MFR VOUT MAX provides the maximum output voltage. The value is reset when read.

Command	MFR VOUT MAX															
Format	Direct															
Bit	15	14	13	12	11	10	9	8	7	6	5	4	3	2	1	0
Access	r	r	r	r	r	r	r	r	r	r	r	r	r	r	r	r
Function																
Default value	0	0	0	0	0	0	0	0	0	0	0	0	0	0	0	0

MFR IOOUT MAX (A6h)

MFR VOUT MAX provides the maximum output current. The value is reset when read.

Command	MFR IOOUT MAX															
Format	Direct															
Bit	15	14	13	12	11	10	9	8	7	6	5	4	3	2	1	0
Access	r	r	r	r	r	r	r	r	r	r	r	r	r	r	r	r
Function																
Default value	0	0	0	0	0	0	0	0	0	0	0	0	0	0	0	0

MFR POUT MAX (A7h)

MFR POUT MAX provides the maximum output power. The value is reset when read.

Command	MFR POUT MAX															
Format	Direct															
Bit	15	14	13	12	11	10	9	8	7	6	5	4	3	2	1	0
Access	r	r	r	r	r	r	r	r	r	r	r	r	r	r	r	r
Function																
Default value	0	0	0	0	0	0	0	0	0	0	0	0	0	0	0	0

MFR TAMBIENT MAX (A8h)

MFR TAMBIENT MAX provides the maximum temperature measured from the E-fuse device. The value is reset when read.

Command	MFR TAMBIENT MAX															
Format	Direct															
Bit	15	14	13	12	11	10	9	8	7	6	5	4	3	2	1	0
Access	r	r	r	r	r	r	r	r	r	r	r	r	r	r	r	r
Function																
Default value	0	0	0	0	0	0	0	0	0	0	0	0	0	0	0	0

USER DATA 00 (B0h)

The PMBus configuration revision is stored in this location. This is used to track the PMBus configuration version.

Command	USER DATA 00															
Format	Direct															
Bit	15	14	13	12	11	10	9	8	7	6	5	4	3	2	1	0
Access	r/w	r/w	r/w	r/w	r/w	r/w	r/w	r/w	r/w	r/w	r/w	r/w	r/w	r/w	r/w	r/w
Function																
Default value	0	0	0	0	0	0	0	0	0	0	0	0	0	0	0	0

USER DATA 01 (B1h)

USER DATA 01 allows storage of user-defined information.

Command	USER DATA 01															
Format	Direct															
Bit	15	14	13	12	11	10	9	8	7	6	5	4	3	2	1	0
Access	r/w	r/w	r/w	r/w	r/w	r/w	r/w	r/w	r/w	r/w	r/w	r/w	r/w	r/w	r/w	r/w
Function																
Default value	0	0	0	0	0	0	0	0	0	0	0	0	0	0	0	0

USER DATA 02 (B2h)

USER DATA 02 allows storage of user-defined information.

Command	USER DATA 02															
Format	Direct															
Bit	15	14	13	12	11	10	9	8	7	6	5	4	3	2	1	0
Access	r/w	r/w	r/w	r/w	r/w	r/w	r/w	r/w	r/w	r/w	r/w	r/w	r/w	r/w	r/w	r/w
Function																
Default value	0	0	0	0	0	0	0	0	0	0	0	0	0	0	0	0

USER DATA 03 (B3h)

USER DATA 03 allows storage of user-defined information.

Command	USER DATA 03															
Format	Direct															
Bit	15	14	13	12	11	10	9	8	7	6	5	4	3	2	1	0
Access	r/w	r/w	r/w	r/w	r/w	r/w	r/w	r/w	r/w	r/w	r/w	r/w	r/w	r/w	r/w	r/w
Function																
Default value	0	0	0	0	0	0	0	0	0	0	0	0	0	0	0	0

USER DATA 04 (B4h)

USER DATA 04 allows storage of user-defined information.

Command	USER DATA 04															
Format	Direct															
Bit	15	14	13	12	11	10	9	8	7	6	5	4	3	2	1	0
Access	r/w	r/w	r/w	r/w	r/w	r/w	r/w	r/w	r/w	r/w	r/w	r/w	r/w	r/w	r/w	r/w
Function																
Default value	0	0	0	0	0	0	0	0	0	0	0	0	0	0	0	0

USER DATA 05 (B5h)

USER DATA 05 allows storage of user-defined information.

Command	USER DATA 05															
Format	Direct															
Bit	15	14	13	12	11	10	9	8	7	6	5	4	3	2	1	0
Access	r/w	r/w	r/w	r/w	r/w	r/w	r/w	r/w	r/w	r/w	r/w	r/w	r/w	r/w	r/w	r/w
Function																
Default value	0	0	0	0	0	0	0	0	0	0	0	0	0	0	0	0

USER DATA 06 (B6h)

USER DATA 06 allows storage of user-defined information.

Command	USER DATA 06															
Format	Direct															
Bit	15	14	13	12	11	10	9	8	7	6	5	4	3	2	1	0
Access	r/w	r/w	r/w	r/w	r/w	r/w	r/w	r/w	r/w	r/w	r/w	r/w	r/w	r/w	r/w	r/w
Function																
Default value	0	0	0	0	0	0	0	0	0	0	0	0	0	0	0	0

USER DATA 07 (B7h)

USER DATA 07 allows storage of user-defined information.

Command	USER DATA 07															
Format	Direct															
Bit	15	14	13	12	11	10	9	8	7	6	5	4	3	2	1	0
Access	r/w	r/w	r/w	r/w	r/w	r/w	r/w	r/w	r/w	r/w	r/w	r/w	r/w	r/w	r/w	r/w
Function																
Default value	0	0	0	0	0	0	0	0	0	0	0	0	0	0	0	0

USER DATA 08 (B8h)

USER DATA 08 allows storage of user-defined information.

Command	USER DATA 08															
Format	Direct															
Bit	15	14	13	12	11	10	9	8	7	6	5	4	3	2	1	0
Access	r/w	r/w	r/w	r/w	r/w	r/w	r/w	r/w	r/w	r/w	r/w	r/w	r/w	r/w	r/w	r/w
Function																
Default value	0	0	0	0	0	0	0	0	0	0	0	0	0	0	0	0

USER DATA 09 (B9h)

USER DATA 09 allows storage of user-defined information.

Command	USER DATA 09															
Format	Direct															
Bit	15	14	13	12	11	10	9	8	7	6	5	4	3	2	1	0
Access	r/w	r/w	r/w	r/w	r/w	r/w	r/w	r/w	r/w	r/w	r/w	r/w	r/w	r/w	r/w	r/w
Function																
Default value	0	0	0	0	0	0	0	0	0	0	0	0	0	0	0	0

USER DATA 10 (BAh)

USER DATA 10 allows storage of user-defined information.

Command	USER DATA 10															
Format	Direct															
Bit	15	14	13	12	11	10	9	8	7	6	5	4	3	2	1	0
Access	r/w	r/w	r/w	r/w	r/w	r/w	r/w	r/w	r/w	r/w	r/w	r/w	r/w	r/w	r/w	r/w
Function																
Default value	0	0	0	0	0	0	0	0	0	0	0	0	0	0	0	0

IOUT AUTO CALIBRATION (E0h)

If IOUT AUTO CALIBRATION is set to 0, the MP5920 measures the offset on the IMON line before enabling the MP5921. This value is used as the offset adjustment value instead of value stored in 39h.

If IOUT AUTO CALIBRATION is set to 0, auto-calibration is enabled. If IOUT AUTO CALIBRATION is set to 1, auto-calibration is disabled, and the I_{OUT} calibration offset is used.

PMBUS PWD (E1h)

PMBUS PWD provides protection for the PMBus registers. When the password has not been written, all PMBus-protected registers respond with 0x0000. Send 0x82C2 to E1h to allow write/read access to all PMBus protected registers. Send 0x0000 to E1h to lock it again.

AVERAGE TIME (E2h)

AVERAGE TIME provides adjustable averaging time that is applied to all telemetry values. A block average is applied to all telemetry values over the time set by this register as shown in Equation (5):

$$Y = (X_{(N)} + X_{(N-1)} + \dots + X_{(0)}) / AVG_N \tag{5}$$

The values in the telemetry registers update at the end of each averaging period. The valid range is 0x02 - 0x9FF.

Command	AVERAGE TIME															
Format	Direct															
Bit	15	14	13	12	11	10	9	8	7	6	5	4	3	2	1	0
Access	r	r	r	r	r	r	r	r	r	r	r	r	r	r	r	r
Function	x	x	x	x	LSB: 200µs											
Default value	0	0	0	0	0	0	0	0	0	0	0	0	0	0	0	0

ADDRESS CONFIGURATION (E4h)

Address configuration lookup table.

Bits	Name	Behavior	Default Set	Description
[15:8]	ADDR DELAY	r/w	0x01	Sets the delay time in reading ADDR from the time the part passes the internal POR. The delay time is determined by ADDRESS DELAY * 800µs.
[7]	ADDR MODE	r/w	0	Sets the address detection mode address loaded from NVM or set by the external voltage on ADDR. 0: address is set by the voltage on ADDR 1: address is set by the value in NVM
[6:4]	ADDR NVM	r/w	0X0	Sets the address stored in NVM, valid range is 0 - 7.
[3:0]	ADDR BASE	r/w	0X40	Sets the base address for the address stored in NVM or set by the external ADDR. Valid range is 0 - F.

Address set by ADDR: When the address is set by ADDR, the address is determined by the voltage measured at ADDR and the values in the ADDR BASE register. If ADDR BASE = Eh, and the voltage measured at ADDR is 1.35V (3h), then the address of the MP5920 is E3h (see Table 3).

Table 3: Slave Address Based on V_{ADDR}

V _{ADDR} (V)	Slave Address
0	0h
0.55	1h
0.95	2h
1.35	3h
1.75	4h
2.15	5h
2.55	6h
3	7h

Address set by NVM: When the address is set by NVM, the address is determined by the value in ADDR NVM and ADDR BASE. If ADDR BASE = Eh, and ADDR NVM = 7h, then the address of the device is E7h.

OTP HYSTERESIS (E5h)

OTP hysteresis sets the temperature where the MP5920 re-enables the E-fuse device once it has been turned off due to an OTP fault (register OT FAULT LIMIT (4Fh) value).

Command	OTP HYSTERESIS															
Format	Direct															
Bit	15	14	13	12	11	10	9	8	7	6	5	4	3	2	1	0
Access	r/w	r/w	r/w	r/w	r/w	r/w	r/w	r/w	r/w	r/w	r/w	r/w	r/w	r/w	r/w	r/w
Function																
Default value	0	0	0	0	0	0	0	0	0	0	0	0	0	0	0	0

GPIO CONFIG (E6h)

GPIO CONFIG sets the operation of GPIO. GPIO can be configured to indicated a programmed fault or alert to the system. Setting the corresponding bit to 1 enables the function output on GPIO (see Table 4).

Command	GPIO CONFIG															
Format	Direct															
Bit	15	14	13	12	11	10	9	8	7	6	5	4	3	2	1	0
Access	r/w	r/w	r/w	r/w	r/w	r/w	r/w	r/w	r/w	r/w	r/w	r/w	r/w	r/w	r/w	r/w
Function																
Default value	0	0	0	0	0	0	0	0	0	0	0	0	0	0	0	0

Table 4: GPIO Functions

Bit	Setting	Description
0	PWRGD	Pin acts as PWR good indicator
1	GOK	Pin replicates GOK input
2	PIN WRN	Pin goes low when pin warning limit is reached
3	POUT WRN	Pin goes low when P _{OUT} warning limit is reached
4	IOUT WRN	Pin goes low when I _{OUT} warning limit is reached
5	DOC WRN	Pin replicates DOC
6	TEMP FAULT	Pin goes low when temp fault occurs
7	OCP FAULT	Pin goes low when OCP fault occurs
8	IIN WARN	Pin goes low when IIN warning is reached
9	TEMP WARN	Pin goes low when temp warning is reached
10	BB WRITE	Pin goes low when black box write occurs
12	NOT USED	Not used
13	NOT USED	Not used
14	NOT USED	Not used
15	NOT USED	Not used

CLREF DUTY CYCLE (E7h)

Current limit CLREF configuration register. The CLREF_CONFIG command is used to configure the hot-swap current limit reference voltage.

Bits	Name	Behavior	Default Set	Description
[7:0]	CLREF	RW	0x00	0x00: no pulse on CLPWM, the CLREF voltage equals 0V 0x01 to 0x64: the value determines the CLPWM output pulse duty cycle. LSB = 1%

BLACK BOX PWD (F0h)

BLACK BOX PWD allows the black box information stored in NVM to be read. Writing 0xBB40 to F0h allows access to stored information. Send 0x0000 to F0h to lock again.

BLACK BOX VIN (F1h)

V_{IN} telemetry data stored when black box trigger occurs.

Byte	Byte Name	Description
0	VIN AVG LOW BYTE	V_{IN} average voltage stored in NVM when BB is triggered
1	VIN AVG HIGH BYTE	
2	VIN MAX LOW BYTE	V_{IN} maximum voltage stored in NVM when BB is triggered
3	VIN MAX HIGH BYTE	
4	VIN MIN LOW BYTE	V_{IN} minimum voltage stored in NVM when BB is triggered
5	VIN MIN HIGH BYTE	

BLACK BOX OUTPUT AVERAGE (F2h)

Output telemetry information stored in NVM when black box trigger occurs.

Byte	Byte Name	Description
0	VOUT AVG LOW BYTE	V_{OUT} average voltage stored in NVM when BB is triggered
1	VOUT AVG HIGH BYTE	
2	IOUT AVG LOW BYTE	I_{OUT} average voltage stored in NVM when BB is triggered
3	IOUT AVG HIGH BYTE	
4	POUT AVG LOW BYTE	P_{OUT} average voltage stored in NVM when BB is triggered
5	POUT AVG HIGH BYTE	
6	TEMP AVG LOW BYTE	Temperature average voltage stored in NVM when BB is triggered
7	TEMP AVG HIGH BYTE	

BLACK BOX OUTPUT MAXIMUM (F4h)

Output telemetry information stored in NVM when black box trigger occurs.

Byte	Byte Name	Description
0	VOUT MAX LOW BYTE	V_{OUT} maximum voltage stored in NVM when BB is triggered
1	VOUT MAX HIGH BYTE	
2	IOUT MAX LOW BYTE	I_{OUT} maximum voltage stored in NVM when BB is triggered
3	IOUT MAX HIGH BYTE	
4	POUT MAX LOW BYTE	P_{OUT} maximum voltage stored in NVM when BB is triggered
5	POUT MAX HIGH BYTE	
6	TEMP MAX LOW BYTE	Temperature maximum voltage stored in NVM when BB is triggered
7	TEMP MAX HIGH BYTE	

BLACK BOX STATUS (F6h)

The status register 79h is stored to NVM, and the faults that occurred during a black box trigger can be viewed.

BLACK BOX CONFIG (FCh)

The black box write must be set via FCh to allow new BB data to be stored when the selected trigger occurs.

Bits	Name	Behavior	Default Set	Description
[15]	BB Write	r/w	0	0: BB has not been written 1: BB has been written BB data can be overridden by writing 0. This allows the next BB trigger to write data to NVM.
[14:10]	reserved		0	
[9]	Vin BB Trigger	r/w	0	0: no trigger enabled 1: V _{IN} under-voltage triggers a BB write
[8]	Vout BB Trigger	r/w	0	0: no trigger enabled 1: when the output voltage falls below the PG level, a BB write occurs
[7]	OTP BB Trigger	r/w	0	0: no trigger enabled 1: when OTP occurs, a BB write also occurs
[6]	Efuse Fault Trigger	r/w	0	0: no trigger enabled 1: GOK assertion causes a BB write
[5:0]	Reserved		0	

NVM PWD (FDh)

The NVM password protects the NVM from accidental writes, sending 0xc4c4 to NVM PWD allows access to NVM writes. Send 0x0000 to NVM PWD to lock it again.

PACKAGE INFORMATION

TQFN-32 (4mmx4mm)

PACKAGE OUTLINE DRAWING FOR 32L TQFN (4X4MM) MF-PO-D-0361 revision 0.0

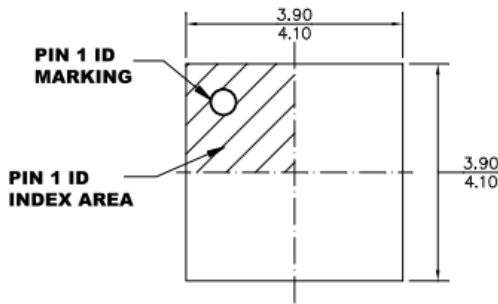

TOP VIEW

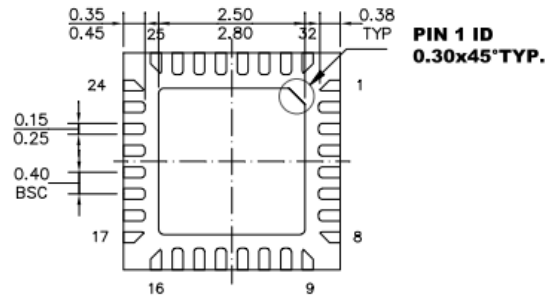

BOTTOM VIEW

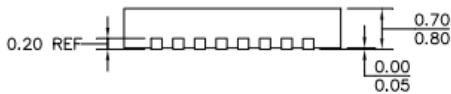

SIDE VIEW

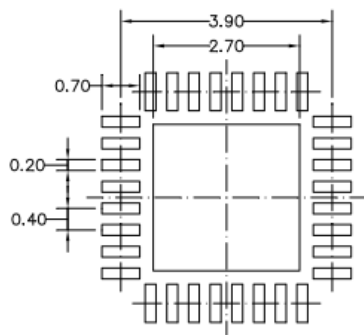

RECOMMENDED LAND PATTERN

NOTE:

- 1) ALL DIMENSIONS ARE IN MILLIMETERS.
- 2) EXPOSED PADDLE SIZE DOES NOT INCLUDE MOLD FLASH.
- 3) LEAD COPLANARITY SHALL BE 0.08 MILLIMETERS MAX.
- 4) JEDEC REFERENCE IS MO-220.
- 5) DRAWING IS NOT TO SCALE.

NOTICE: The information in this document is subject to change without notice. Users should warrant and guarantee that third party Intellectual Property rights are not infringed upon when integrating MPS products into any application. MPS will not assume any legal responsibility for any said applications.