



DESCRIPTION

The MP4030 is a TRIAC-dimmable, primary-side-control, offline LED lighting controller with active PFC. It can output an accurate LED current for an isolated lighting application with a single-stage converter. The proprietary real-current-control method can accurately control the LED current using primary-side information. It can significantly simplify LED lighting system design by eliminating secondary-side feedback components and the optocoupler.

The MP4030 implements power-factor correction and works in boundary-conduction mode to reduce MOSFET switching losses.

The MP4030 has an integrated charging circuit at the supply pin for fast start-up without a perceptible delay.

The proprietary dimming control expands the TRIAC-based dimming range.

The MP4030 has multiple protections that greatly enhance system reliability and safety, and include over-voltage protection, short-circuit protection, programmable primary-side over-current protection, supply-pin under-voltage lockout, and over-temperature protection.

All fault protections feature auto-restart.

The MP4030 is available in an 8-pin SOIC package.

FEATURES

- Primary-Side-Control without Requiring a Secondary-Side Feedback Circuit
- Internal Charging Circuit at the Supply Pin for Fast Start-Up
- Accurate Line Regulation
- High Power Factor
- Flicker-Free, Phase-Controlled TRIAC Dimming with Expanded Dimming Range.
- Operates in Boundary Conduction Mode
- Cycle-by-Cycle Current Limit
- Programmable Primary-Side Over-Current Protection
- Over-Voltage Protection
- Short-Circuit Protection
- Over-Temperature Protection
- Available in an 8-Pin SOIC Package

APPLICATIONS

- Solid-State Lighting, including:
- Industrial and Commercial Lighting
- Residential Lighting

All MPS parts are lead-free and adhere to the RoHS directive. For MPS green status, please visit MPS website under Products, Quality Assurance page.
"MPS" and "The Future of Analog IC Technology" are registered trademarks of Monolithic Power Systems, Inc.

TYPICAL APPLICATION

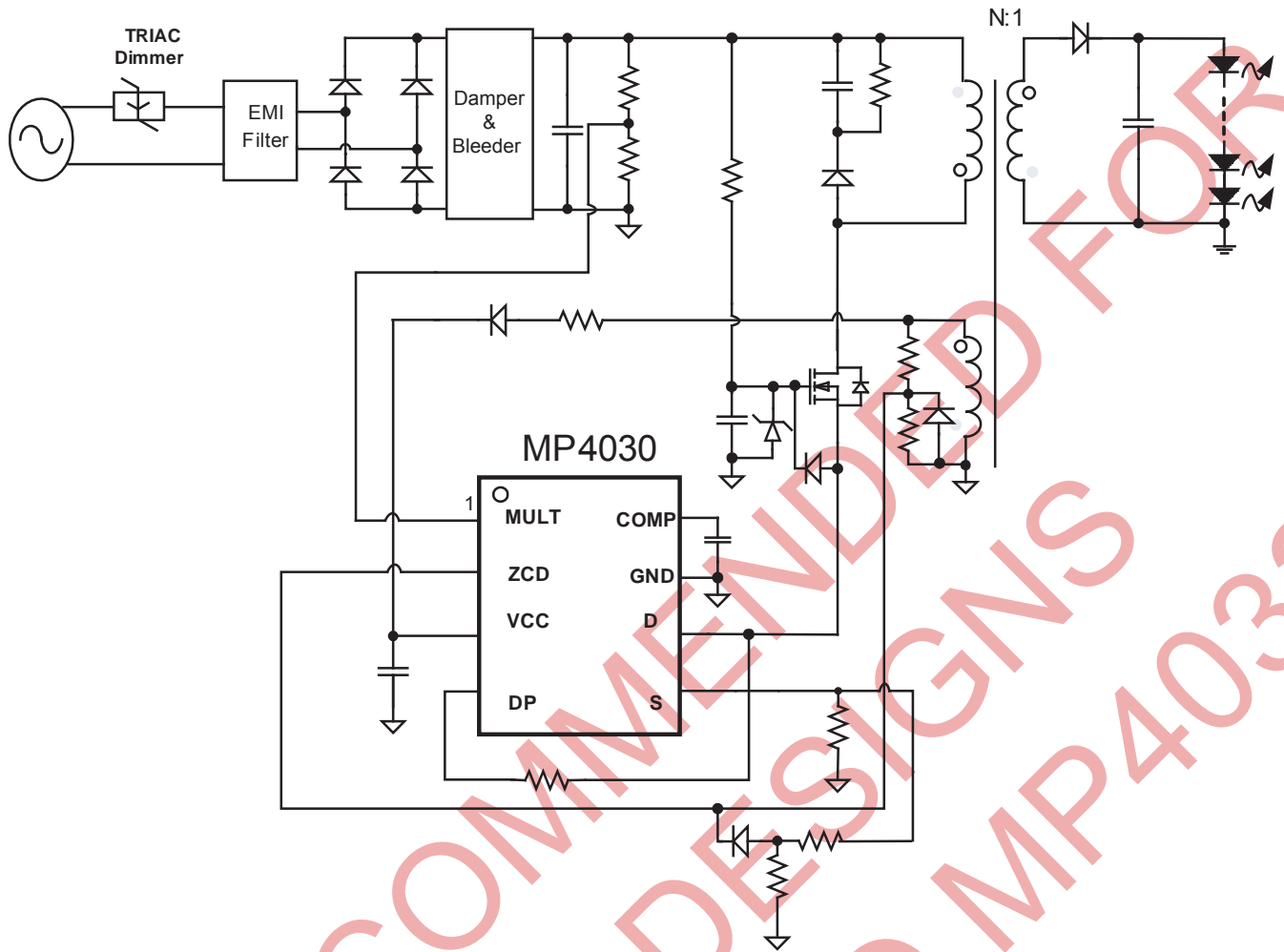

NOT RECOMMENDED FOR NEW DESIGNS REFER TO MP4033

ORDERING INFORMATION

| Part Number* | Package | Top Marking |
|--------------|---------|-------------|
| MP4030GS | SOIC8 | MP4030 |

* For Tape & Reel, add suffix -Z (e.g. MP4030GS-Z);

PACKAGE REFERENCE

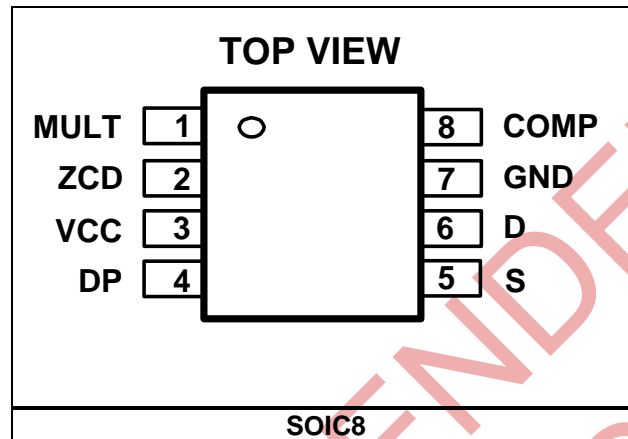

ABSOLUTE MAXIMUM RATINGS ⁽¹⁾

| | |
|--|-----------------|
| VCC Pin Voltage | -0.3V to +30V |
| Low-Side MOSFET Drain Voltage | -0.7V to +30V |
| ZCD Pin Voltage | -8V to +7V |
| Other Analog Inputs and Outputs | -0.3V to 7V |
| ZCD Pin Current | -5mA to +5mA |
| Continuous Power Dissipation (T _A = +25°C) ⁽²⁾ | |
| SOIC8 | 1.3W |
| Junction Temperature | 150°C |
| Lead Temperature | 260°C |
| Storage Temperature | -65°C to +150°C |

Recommended Operating Conditions ⁽³⁾

| | |
|---|-----------------|
| VCC Pin Voltage | 11V to 27V |
| Operating Junction Temp (T _J) | -40°C to +125°C |

Thermal Resistance ⁽⁴⁾

| | θ_{JA} | θ_{JC} |
|-------|---------------|---------------|
| SOIC8 | 96 | 45 |

°C/W

Notes:

- Exceeding these ratings may damage the device.
- The maximum allowable power dissipation is a function of the maximum junction temperature T_J(MAX), the junction-to-ambient thermal resistance θ_{JA} , and the ambient temperature T_A. The maximum allowable continuous power dissipation at any ambient temperature is calculated by P_D(MAX)=(T_J(MAX)-T_A)/ θ_{JA} . Exceeding the maximum allowable power dissipation will cause excessive die temperature, and the regulator will go into thermal shutdown. Internal thermal shutdown circuitry protects the device from permanent damage.
- The device is not guaranteed to function outside of its operation conditions.
- Measured on JESD51-7 4-layer board.

ELECTRICAL CHARACTERISTICS

T_A = +25°C, unless otherwise noted.

| Parameter | Symbol | Condition | Min | Typ | Max | Units |
|--|---------------------------|--|-------|------|-------|-------|
| Supply Voltage | | | | | | |
| Operating Range | V _{CC} | After turn on | 10 | | 27 | V |
| V _{CC} Upper Level: Internal Charging Circuit Stops and IC Turns On | V _{CCH} | | 9.5 | 10 | 10.5 | V |
| V _{CC} Lower Level: Internal Charging Circuit Triggers | V _{CCL} | | 8.55 | 9 | 9.45 | V |
| V _{CC} Re-charge and IC turns off Level in Fault Condition | V _{CCEN} | Fault condition | 6.55 | 7 | 7.45 | V |
| Supply Current | | | | | | |
| V _{CC} Charging Current from D | I _{D_Charge} | VD=16V, V _{CC} =5V | 12.5 | 15 | 17.5 | mA |
| Quiescent Current | I _Q | No switching, V _{CC} =15V | | 800 | 1000 | μA |
| Quiescent Current at Fault | I _{Q_Fault} | Fault condition, IC latch, V _{CC} =15V | 180 | 220 | 300 | μA |
| Operating Current | I _{cc} | f _s =70kHz, V _{CC} =15V | | 1 | 2 | mA |
| Multiplier | | | | | | |
| Linear Operation Range | V _{MULT} | V _{COMP} from 1.9V to 4.9V | 0 | | 3 | V |
| Gain | K ⁽⁵⁾ | V _{COMP} =2V, V _{MULT} =0.5V | 0.84 | 1.06 | 1.26 | 1/V |
| | | V _{COMP} =2V, V _{MULT} =1.5V | 0.9 | 1.08 | 1.23 | 1/V |
| | | V _{COMP} =2V, V _{MULT} =3V | 0.93 | 1.1 | 1.25 | 1/V |
| TRIAC Dimming OFF Detection Threshold | V _{MUL_OFF} | | 0.13 | 0.15 | 0.17 | V |
| TRIAC Dimming ON Detection Threshold | V _{MUL_ON} | | 0.32 | 0.35 | 0.38 | V |
| TRIAC Dimming OFF Line-Cycle Blanking Ratio | D _{OFF_LEB} | | | 25% | | |
| Dimming Pull-Down MOSFET Turn-ON Threshold | V _{MULT_DP_ON} | | 0.22 | 0.25 | 0.28 | V |
| Dimming Pull down MOSFET Turn-OFF Delay Time | t _{DP_OFF_Delay} | starts at the rising edge of V _{MULT} =V _{MULT_ON} | 150 | 200 | 250 | μs |
| Error Amplifier | | | | | | |
| Reference Voltage | V _{REF} | | 0.386 | 0.4 | 0.414 | V |
| Transconductance | G _{EA} | Guaranteed by design | | 250 | | μA/V |
| COMP Lower Clamp Voltage | V _{COMPL} | | 1.85 | 1.9 | 1.95 | V |
| Max. Source Current | I _{COMP+} | | | 57 | | μA |
| Max. Sink Current without Dimmer | I _{COMP-} | | | -300 | | μA |
| Sink Current at TRIAC Dimming Off | I _{Sink_Dim} | | 63 | 70 | 77 | μA |
| Short-Circuit Detect Threshold | V _{COMP_SCP} | | 4.85 | 5 | 5.15 | V |

ELECTRICAL CHARACTERISTICS (continued)

 T_A = +25°C, unless otherwise noted.

| Parameter | Symbol | Condition | Min | Typ | Max | Units |
|--|--------------------------|-------------------------|------|------|------|-------|
| Current Sense Comparator | | | | | | |
| Leading Edge Blanking Time | t _{LEB} | | 575 | 685 | 795 | ns |
| Current Sense Upper Clamp Voltage | V _{S_Clamp_H} | | 2.2 | 2.3 | 2.4 | V |
| Current Sense Lower Clamp Voltage | V _{S_Clamp_L} | | 0.08 | 0.1 | 0.12 | V |
| Zero-Current Detector | | | | | | |
| Zero-Current-Detect Threshold | V _{ZCD_T} | Falling Edge | 0.32 | 0.35 | 0.37 | V |
| Zero-Current-Detect Hystestic | V _{ZCD_HY} | | 520 | 550 | 580 | mV |
| Zero-Current-Detect LEB | t _{ZCD_LEB} | Starts at Gate Turn Off | 1.8 | 2.5 | 3.1 | µs |
| Over-Voltage Threshold | V _{ZCD_OVP} | | 5.2 | 5.5 | 5.8 | V |
| OVP Detect LEB | t _{OVP_LEB} | Starts at Gate Turn Off | 1.5 | 2 | 2.5 | µs |
| Over-Current Threshold | V _{ZCD_OCP} | | 0.81 | 0.9 | 0.99 | V |
| OCB Blanking Time | t _{LEB_OCP} | Starts at Gate Turn On | 575 | 685 | 795 | ns |
| Minimum Off Time | t _{OFF_MIN} | | 4.2 | 5.6 | 7 | µs |
| Starter | | | | | | |
| Start Timer Period | T _{start} | | 90 | 115 | 140 | µs |
| Internal Main MOSFET | | | | | | |
| Breakdown Voltage | BV _{DSS_Main} | V _{GS} =0 | 30 | | | V |
| Drain-Source On-Resistor | R _{DS(ON)_Main} | I _D =100mA | 200 | 250 | 300 | mΩ |
| Internal Dimming Pull Down MOSFET | | | | | | |
| Breakdown Voltage | BV _{DSS_DP} | V _{GS} =0 | 30 | | | V |
| Drain-Source On-Resistor | R _{DS(ON)_DP} | I _D =50mA | 22 | 26 | 30 | Ω |

Notes:

 5) The multiplier output is given by: $V_s = K \cdot V_{MULT} \cdot (V_{COMP} - 1.5)$

PIN FUNCTIONS

| Pin # | Name | Pin Function |
|-------|------|--|
| 1 | MULT | One of the Internal Multiplier Input. Connect to the tap of resistor divider from the rectified voltage of the AC line. The half-wave sinusoid signal to this pin provides a reference signal for the internal current control loop. The MULT pin also detects the TRIAC dimming phase. |
| 2 | ZCD | Zero-Current Detection. A negative going edge triggers the internal MOSFET's turn-on signal. Connect to the tap of a resistor divider from the auxiliary winding to GND. The ZCD pin can also detect over-voltage and over-current conditions. Over-voltage occurs if V_{ZCD} exceeds the over-voltage-protection (OVP) threshold after a 2 μ s blanking time when the internal MOSFET turns off. Over-current occurs if V_{ZCD} exceeds 0.9V during the gate-on interval after the leading edge blanking time |
| 3 | VCC | Supply Voltage. Supplies power for both the control signal and the internal MOSFET's gate driver. Connect to an external bulk capacitor—typically 22 μ F with a 100pF ceramic capacitor to reduce noise. |
| 4 | DP | Dimming Pull-Down. Drain of the internal dimming pull-down MOSFET. Connect a resistor from this pin to the D pin to pull down the rectified input voltage during the TRIAC dimming OFF interval. |
| 5 | S | Internal Low-Side main MOSFET Source. Connect a resistor from this pin to GND to sense the internal MOSFET current. An internal comparator compares the resulting voltage to the internal sinusoid shaped current reference signal to determine when the MOSFET turns off. If the voltage exceeds the current-limit threshold of 2.3V after the leading edge blanking time during the turn-on interval, the gate signal turns off. |
| 6 | D | Internal Low-Side main MOSFET Drain. This pin also internally connects to VCC via a diode and a JFET to form an internal charging circuit for VCC. Connect to the source of the high-side MOSFET. |
| 7 | GND | Ground. Current return of the control signal and the gate drive signal. |
| 8 | COMP | Loop Compensation. Connects to a compensation network to stabilize the LED driver and accurately control the LED driver current. The COMP pin can also monitor for short-circuit conditions: if the COMP voltage rises above 5V, the short-circuit protection triggers. |

TYPICAL PERFORMANCE CHARACTERISTICS

$V_{IN} = 120VAC$, 7 LEDs in series, $I_O = 350mA$, $V_O = 22V$, $L_m = 1.6mH$, $N_p:N_s:N_{AUX} = 82:16:19$, TRIAC dimmable.

Steady State

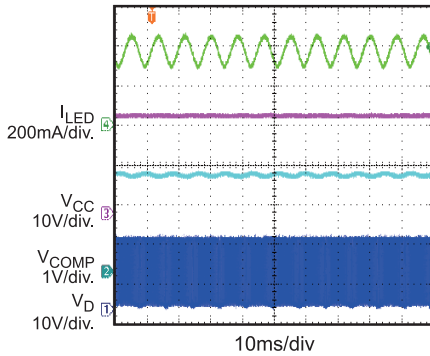

Steady State

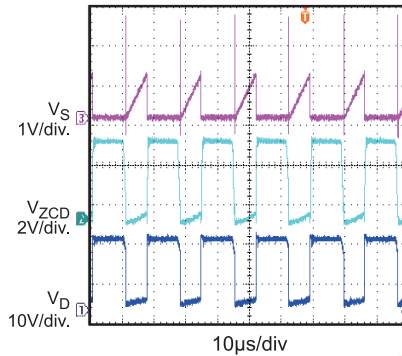

Steady State

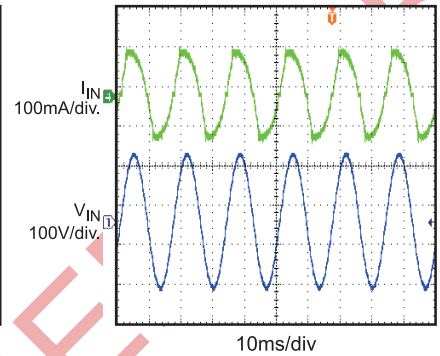

V_{IN} Start Up

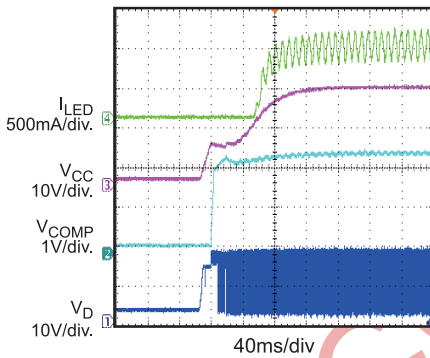

Short Circuit Protection
LED + Short to LED When Working

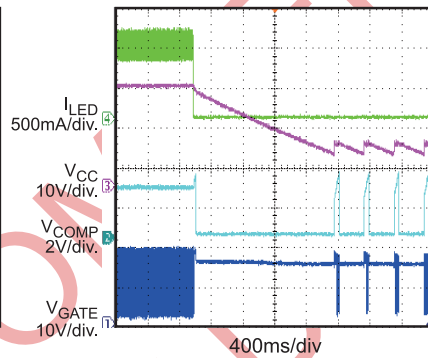

Over Voltage Protection
LED Load Open When Working

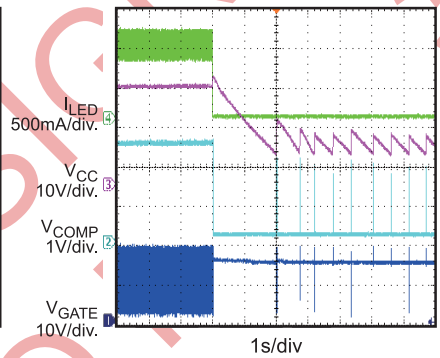

Triac Dimming
D=60%

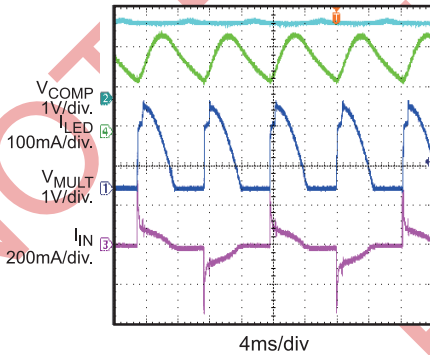

Triac Dimming
D=40%

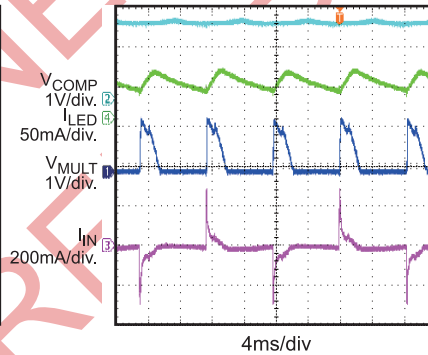

Triac Dimming
D=20%

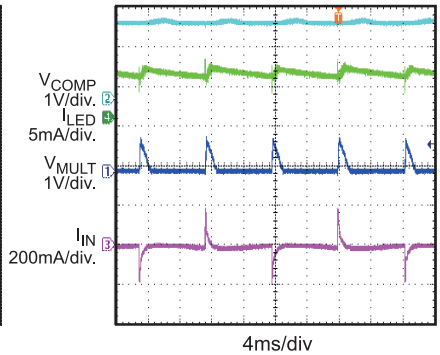

TYPICAL PERFORMANCE CHARACTERISTICS (continued)

V_{IN} =120VAC, 7 LEDs in series, I_O =350mA, V_O =22V, L_m =1.6mH, $N_P:N_S:N_{AUX}$ =82:16:19, TRIAC dimmable.

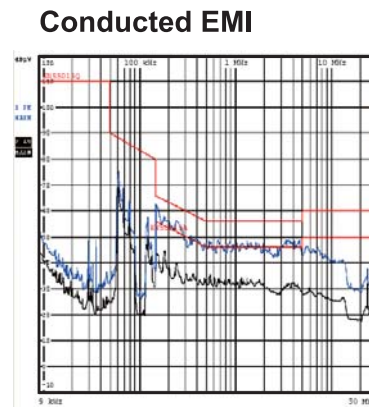
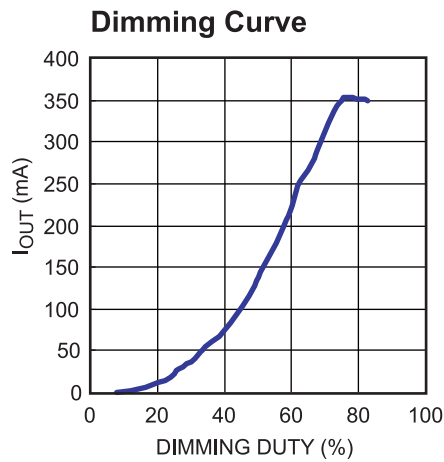
Performance Data

| | | | |
|-----------------------------|--------|--------|--------|
| V_{in} (VAC) | 108V | 120V | 132V |
| P_{in} (W) | 9.58W | 9.54W | 9.47W |
| PF | 0.993 | 0.99 | 0.982 |
| THD | 7.00% | 9.50% | 11.60% |
| I_o (A) | 0.36A | 0.364A | 0.364A |
| V_o (V) | 21.62V | 21.65V | 21.64V |
| Efficiency | 81.20% | 82.60% | 83.10% |

TYPICAL PERFORMANCE CHARACTERISTICS (continued)

$V_{IN} = 230VAC$, 10 LEDs in series, $I_O = 530mA$, $V_O = 30V$, $L_m = 2.15mH$, $N_P : N_S : N_{AUX} = 145 : 29 : 19$, TRIAC dimmable, with ripple suppressor, refer to Figure 20.

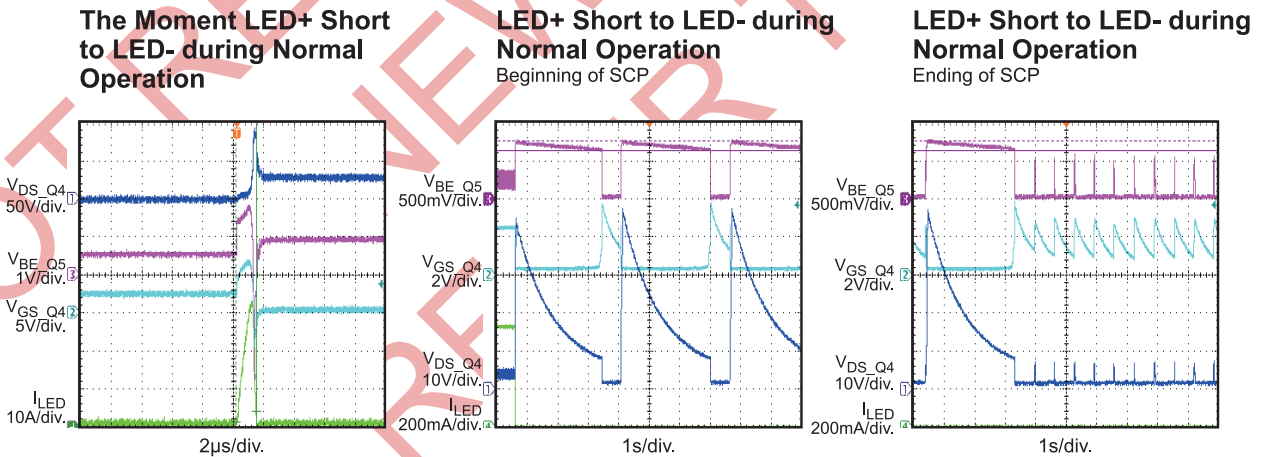
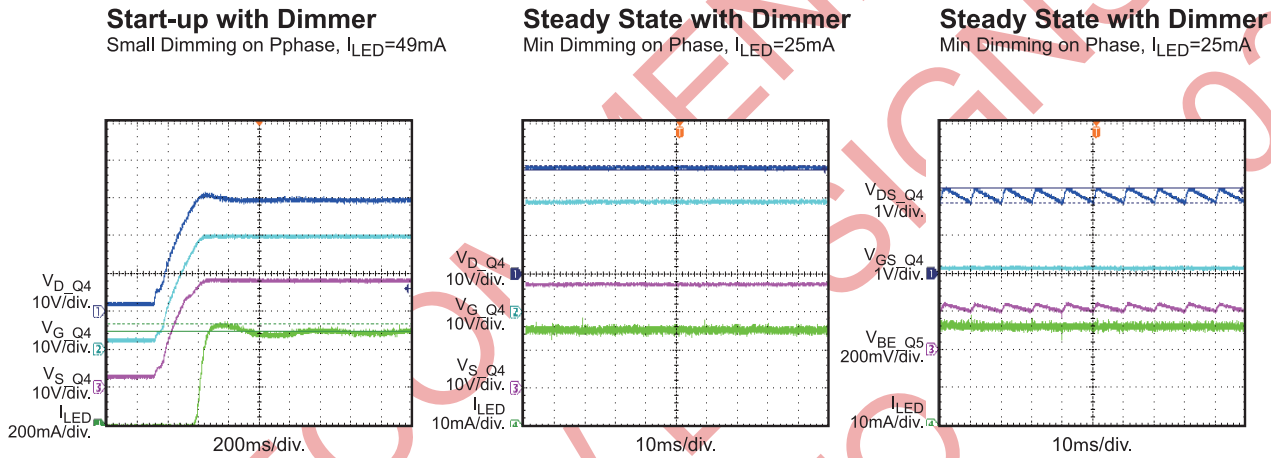
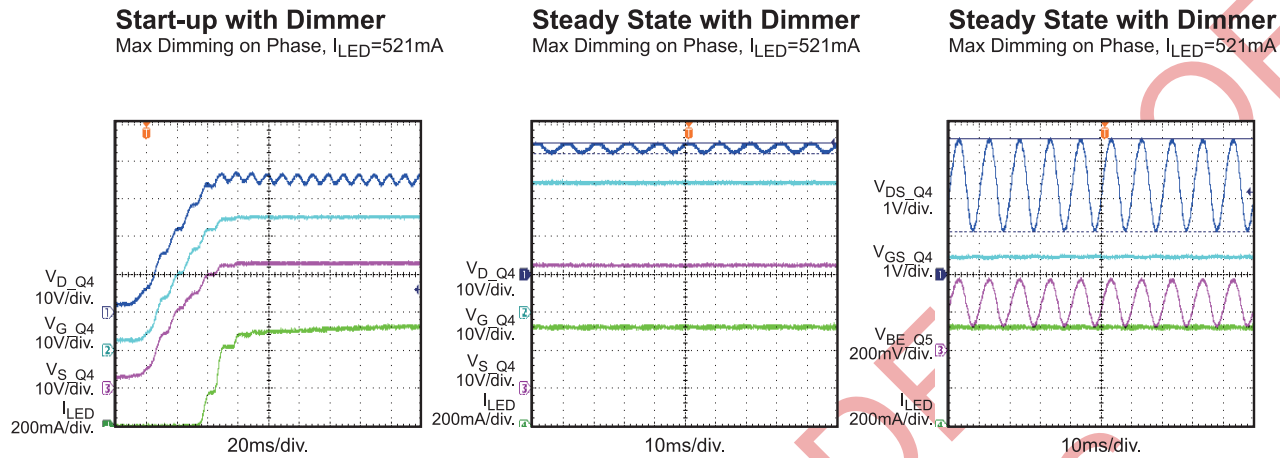

TYPICAL PERFORMANCE CHARACTERISTICS *(continued)*

V_{IN} =230VAC, 10 LEDs in series, I_O =530mA, V_O =30V, L_m =2.15mH, $N_p:N_s:N_{AUX}$ =145:29:19, TRIAC dimmable, with ripple suppressor, refer to Figure 20.

LED+ Short to LED- before Start-up then Recovery

Output Open at Normal Operation then Recovery

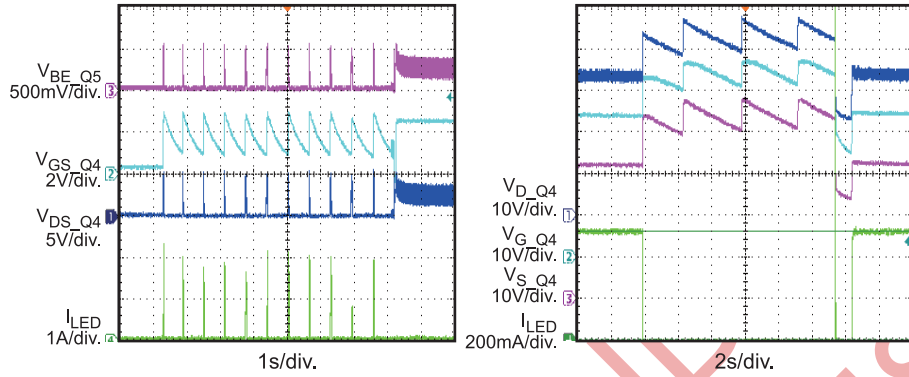

NOT RECOMMENDED FOR NEW DESIGNS REFER TO MP4033

FUNCTION DIAGRAM

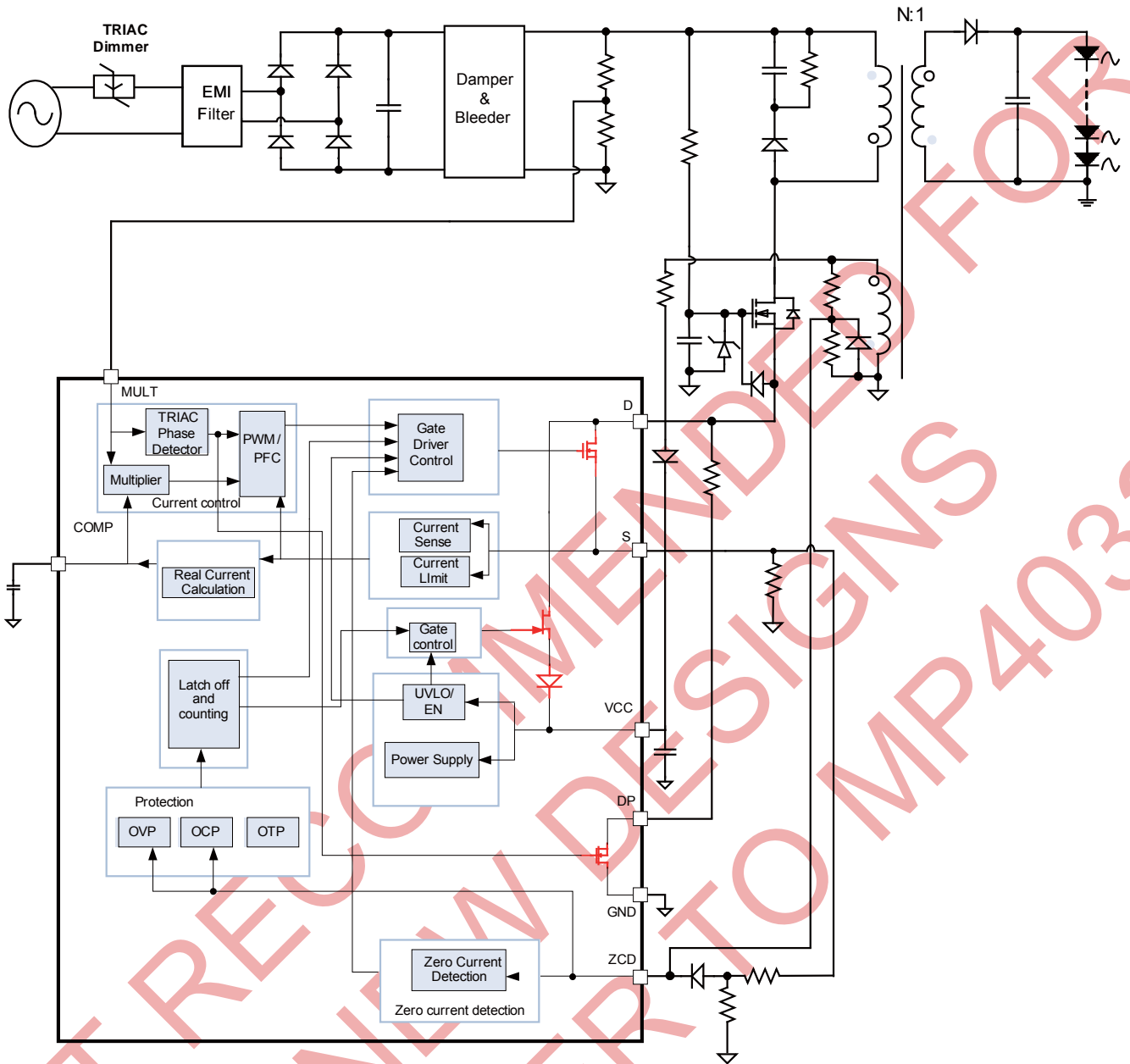

Figure 1: Functional Block Diagram

OPERATION

The MP4030 is a TRIAC-dimmable, primary-side-control, offline LED controller designed for high-performance LED lighting. The MP4030 can accurately control the LED current using the real-current-control method based on primary-side information. It can also achieve a high power factor to eliminate noise pollution on the AC line. The integrated V_{CC} charging circuit can achieve fast start-up without any perceptible delay. The MP4030 is suitable for TRIAC-based dimming with an extended dimming range.

Boundary-Conduction Mode

During the external MOSFET ON time (t_{ON}), the rectified input voltage applied across the primary-side inductor (L_m) increases the primary current increases linearly from zero to the peak value (I_{PK}). When the external MOSFET turns off, the energy stored in the inductor forces the secondary side diode to turn on, and the inductor current decreases linearly from the peak value to zero. When the current decreases to zero, the parasitic resonance caused by the inductor and the combined parasitic capacitances decreases the MOSFET drain-source voltage that is also reflected on the auxiliary winding (see Figure 2). The zero-current detector generates the external MOSFET turn-on signal when the ZCD voltage falls below 0.35V after a blanking time and ensures the MOSFET turns on at a relatively low voltage (see Figure 3).

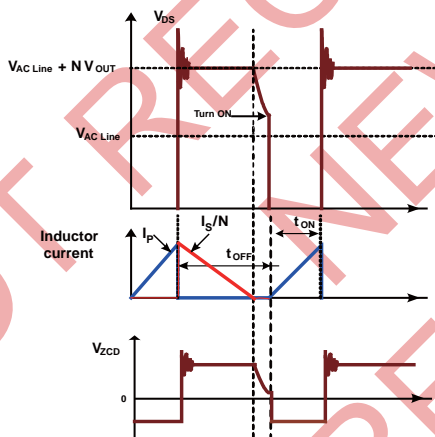

Figure 2: Boundary-Conduction Mode

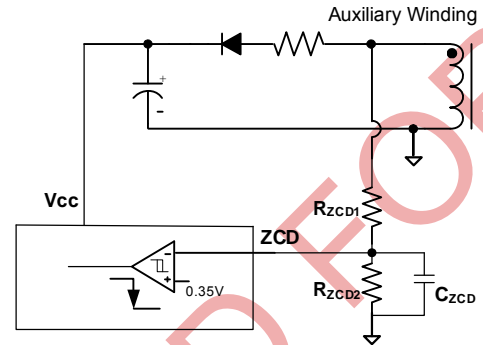

Figure 3: Zero-Current Detector

As a result, there are virtually no primary switch turn-on losses and no secondary-diode reverse-recovery losses. This ensures high efficiency and low EMI noise.

Real-Current-Control

The proprietary real-current-control method allows the MP4030 to control the secondary-side LED current based on primary-side information. The output LED mean current can be calculated approximately as:

$$I_o \approx \frac{N \cdot V_{FB}}{2 \cdot R_s}$$

Where:

- N is the turn ratio of the primary side to the secondary side,
- V_{FB} is the feedback reference voltage (typically 0.4), and
- R_s is the sense resistor between the MOSFET source and GND.

Power-Factor Correction

The MULT pin connects to the tap of a resistor divider from the rectified instantaneous line voltage. The multiplier output also has a sinusoidal shape. This signal provides the reference for the current comparator against the primary-side-inductor current, which shapes the primary-peak current into a sinusoid with the same phase as the input line voltage. This achieves a high power factor.

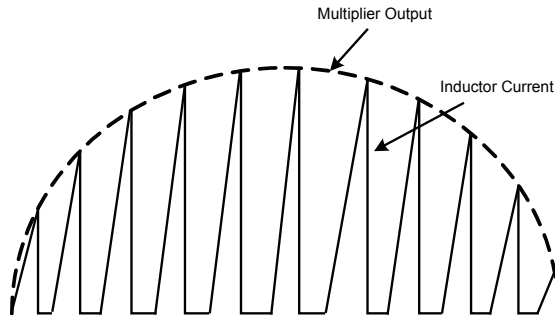

Figure 4: Power-Factor Correction

The multiplier’s maximum output voltage to the current comparator is clamped to 2.3V to limit the cycle-by-cycle current. The multiplier’s minimum output voltage is clamped to 0.1 to ensure a turn-on signal during the TRIAC dimming OFF interval, which pulls down the rectifier input voltage and accurately detects the dimming phase.

V_{CC} Timing Sequence

Initially, V_{CC} is charged through the internal charging circuit from the AC line. When V_{CC} reaches 10V, the internal charging circuit stops charging, the control logic initializes and the internal main MOSFET begins to switch. Then the auxiliary winding takes over the power supply. However, the initial auxiliary-winding positive voltage may not be large enough to charge V_{CC}, causing V_{CC} to drop. Instead, if the V_{CC} drops below the 9V threshold, the internal charging circuit triggers and charges V_{CC} to 10V again. This cycle repeats until the auxiliary winding voltage is high enough to power V_{CC}.

If any fault occurs during this time, the switching and the internal charging circuit will stop and latch, and V_{CC} drops. When V_{CC} decreases to 7V, the internal charging circuit re-charges for auto-restart.

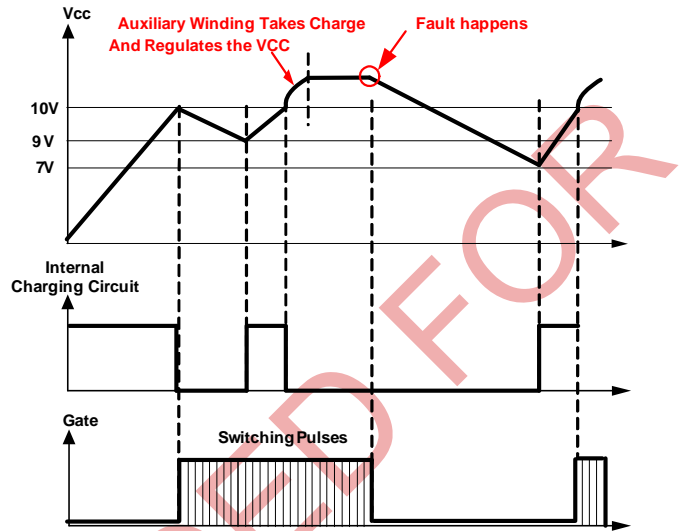

Figure 5: V_{CC} Timing Sequence

Auto Start

The MP4030 includes an auto starter that starts timing when the MOSFET turns off. If ZCD fails to send a turn-on signal after 122μs, the starter will automatically send a turn-on signal to avoid unnecessary I_c shutdowns if ZCD fails.

Minimum OFF Time

The MP4030 operates with a variable switching frequency; the frequency changes with the instantaneous input-line voltage. To limit the maximum frequency and get good EMI performance, the MP4030 employs an internal minimum OFF-time limiter of 5.6μs, as shown in Figure 6.

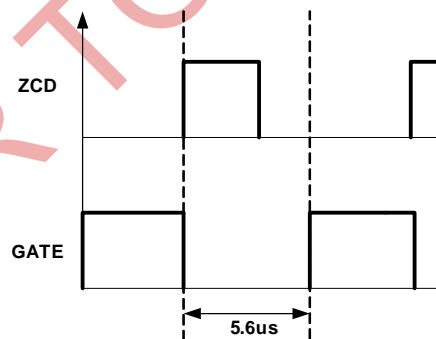

Figure 6: Minimum OFF time

Leading-Edge Blanking

In order to avoid premature switching-pulse termination due to the parasitic capacitances discharging when the MOSFET turns on, an internal leading-edge blanking (LEB) unit between the S pin and the current-comparator input blocks the path from the S pin to the current comparator input during the blanking time. Figure 7 shows the leading-edge blanking.

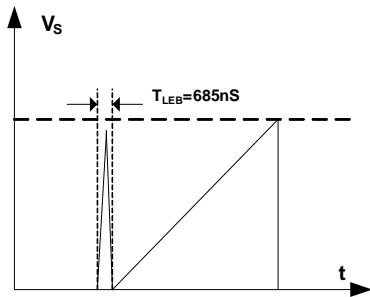

Figure 7: Leading-Edge Blanking

Output Over-Voltage Protection (OVP)

Output over-voltage protection (OVP) prevents component damage from over-voltage conditions. The auxiliary winding voltage's positive plateau is proportional to the output voltage, and the OVP monitors this auxiliary winding voltage instead of directly monitoring the output voltage as shown in Figure 8. Once the ZCD pin voltage exceeds 5.5V, the OVP signal triggers and latches, the gate driver turns off, and the IC enters quiescent mode. When the V_{CC} drops below the UVLO threshold, the IC shuts down and the system restarts. The output OVP set point can be calculated as:

$$V_{OUT_OVP} \cdot \frac{N_{AUX}}{N_{SEC}} \cdot \frac{R_{ZCD2}}{R_{ZCD1} + R_{ZCD2}} = 5.5V$$

Where:

V_{OUT_OVP} is the output OVP threshold,

N_{AUX} is the number of auxiliary winding turns, and

N_{SEC} is the number of secondary winding turns

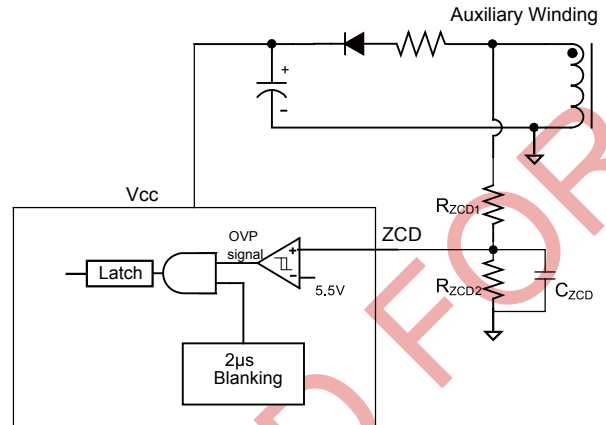

Figure 8: OVP Sampling Circuit

To avoid switch-on spikes mis-triggering OVP, OVP sampling has a t_{OVPS} blanking period of around $2\mu s$, as shown in Figure 9.

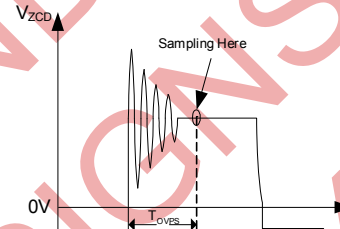

Figure 9: ZCD Voltage and OVP Sampling

Output Short-Circuit Protection (SCP)

In the event of an output short-circuit, the COMP voltage rises. When the voltage reaches 5V, the IC will shut down and restart until V_{CC} drops below UVLO.

Primary Over-Current Protection (OCP)

The ZCD pin has an internally-integrated comparator for primary OCP. When the gate is on, the comparator is enabled. Over-current occurs when V_{ZCD} exceeds 0.9V after a blanking time. Then the IC shuts down and restarts until V_{CC} dropping below UVLO. Figure 10 shows ZCD OCP.

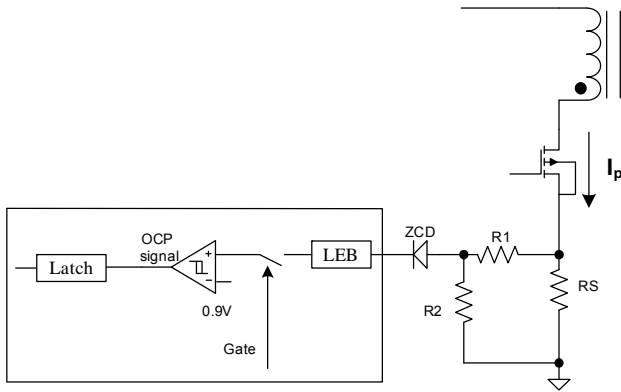

Figure 10: ZCD Over-Current Protection Circuit

Thermal Shutdown

To prevent internal temperatures from exceeding 150°C and causing lethal thermal damage, the MP4030 shuts down the switching cycle and latched until V_{CC} dropping below UVLO and restarts again.

TRIAC-Based Dimming Control

The MP4030 can implement TRIAC-based dimming. The TRIAC dimmer usually consists of a bi-directional SCR with an adjustable turn-on phase. Figure 11 shows the leading-edge TRIAC dimmer waveforms.

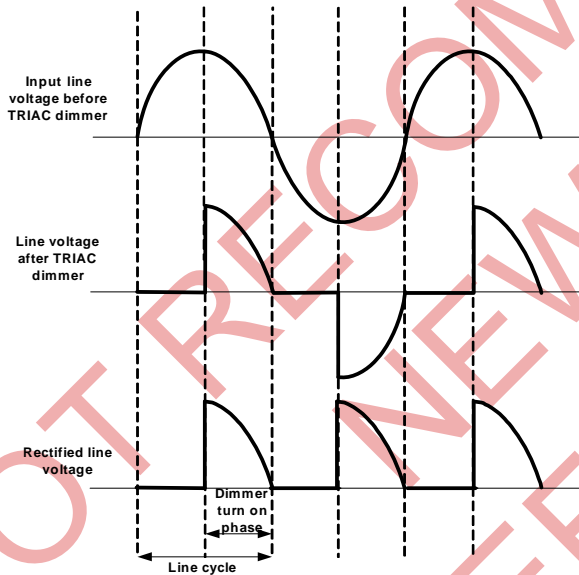

Figure 11: TRIAC Dimmer Waveforms

The MP4030 detects the dimming turn-on cycle through the MULT pin, which is fed into the control loop to adjust the internal reference voltage. When the MULT voltage exceeds 0.35V, the device treats this signal as a dimmer turn-on signal. When the MULT voltage falls below 0.15V, the system treats this as a dimmer turn-off signal. The MP4030 has a 25% line-cycle-detection blanking time with each line cycle. The real phase detector output adds this time, as shown in Figure 12. That means if the turn-on cycle exceeds 75% of the line cycle, the output remains at the same maximum current. It improves the line regulation during the maximum TRIAC turn-on cycle or without a dimmer.

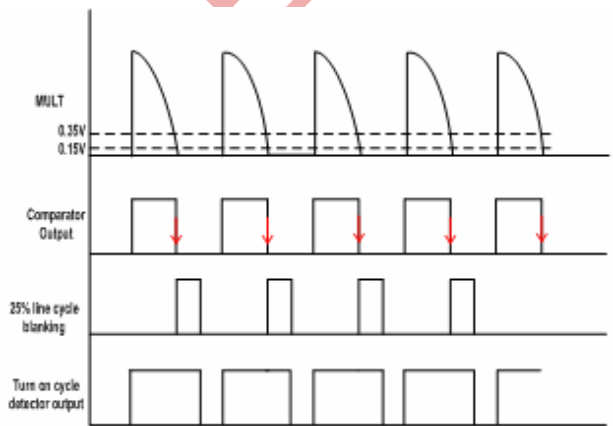

Figure 12: Dimming Turn-On Cycle Detector

If the turn-on cycle decreases to less than 75% of the line cycle, the internal reference voltage decreases as the dimming turn-on phase decreasing, and the output current decreases accordingly to implement dimming. As the dimming turn-on cycle decreases, the COMP voltage also decreases. Once the COMP voltage reaches to 1.9V, it is clamped so that the output current decreases slowly to maintain the TRIAC holding current and avoid random flicker. Figure 13 shows the relationship between the dimming turn-on phase and output current.

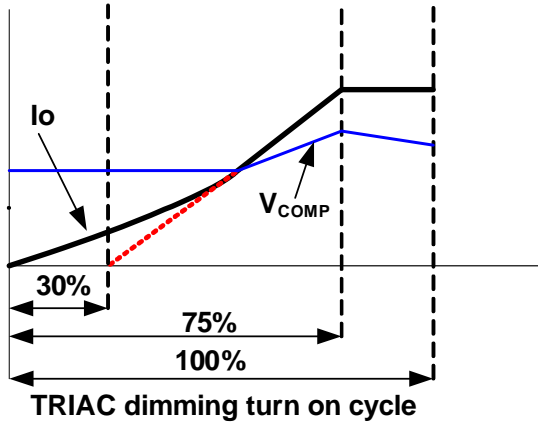

Figure 13: Dimming Curve

Dimming Pull-Down MOSFET

The DP MOSFET turns on when the MULT decreases to 0.25V. Connect a resistor to the D pin to provide the pull-up current during the dimming turn-off interval, and pull down the rectified line voltage to zero quickly to avoid any mis-detection on the MULT pin.

NOT RECOMMENDED FOR NEW DESIGNS REFER TO MP4033

RIPPLE SUPPRESSOR

(Innovative Proprietary)

For dimming LED lighting application, a single stage PFC converter needs large output capacitor to reduce the ripple whose frequency is double of the Grid. And in deep dimming situation, the LED would shimmer caused by the dimming on duty which is not all the same in every line cycle. What's more, the Grid has noise or inrush which would bring out shimmer even flicker. Figure 14 shows a ripple suppressor, which can shrink the LED current ripple obviously.

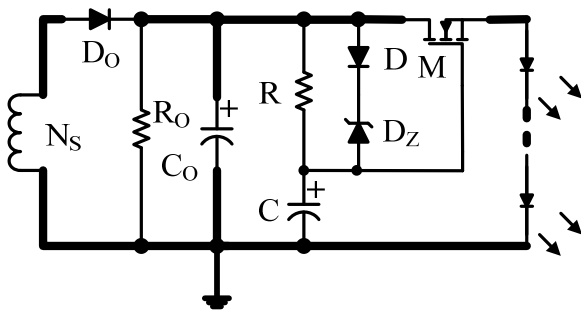

Figure14: Ripple Suppressor

Principle:

Shown in Figure 14, Resistor R, capacitor C, and MOSFET M compose the ripple suppressor. Through the RC filter, C gets the mean value of the output voltage V_{Co} to drive the MOSFET M. M works in variable resistance area. C's voltage V_C is steady makes the LEDs voltage is steady, so the LEDs current will be smooth. MOSFET M holds the ripple voltage v_{co} of the output.

Diode D and Zener diode D_Z are used to restrain the overshoot at start-up. In the start-up process, through D and D_Z , C is charged up quickly to turn on M, so the LED current can be built quickly. When V_C rising up to about the steady value, D and D_Z turn off, and C combines R as the filter to get the mean voltage drop of V_{Co} .

The most important parameter of MOSFET M is the threshold voltage V_{th} which decides the power loss of the ripple suppressor. Lower V_{th} is better if the MOSFET can work in variable resistance area. The BV of the MOSFET can be selected as double as V_{Co} and the Continuous Drain current level can be selected as decuple as the LEDs' current at least.

About the RC filter, it can be selected by $\tau_{RC} \geq 50 / f_{LineCycle}$. Diode D can select 1N4148,

and the Zener voltage of D_Z is as small as possible when guarantee $V_D + V_{DZ} > 0.5 \cdot V_{Co_PP}$.

Optional Protection Circuit

In large output voltage or large LEDs current application, MOSFET M may be destroyed by over-voltage or over-current when LED+ shorted to LED- at working.

Gate-Source(GS) Over-voltage Protection:

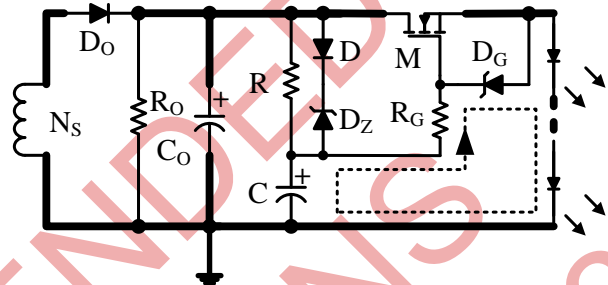

Figure 15: Gate-Source OVP Circuit

Figure 15 shows GS over-voltage protection circuit. Zener diode D_G and resistor R_G are used to protect MOSFET M from GS over-voltage damaged. When LED+ shorted to LED- at normal operation, the voltage drop on capacitor C is high, and the voltage drop on Gate-Source is the same as capacitor C. The Zener diode D_G limits the voltage V_{GS} and R_G limits the charging current to protect D_G . R_G also can limit the current of D_Z at the moment when LED+ shorted to LED-. V_{DG} should bigger than V_{th} .

Drain-Source Over-voltage and Over-current Protection

As Figure 16 shows, NPN transistor T, resistor R_C and R_E are set up to protect MOSFET M from over-current damaged when output short occurs at normal operation. When LED+ shorted to LED-, the voltage v_{DS} of MOSFET is equal to the v_{Co} which has a high surge caused by the parasitic parameter. Zener Diode D_{DS} protects MOSFET from over-voltage damaged. Transistor T is used to pull down the V_{GS} of M. When M turns off, the load is opened, MP4030 detects there is an OVP happened, so the IC functions in quiescent. The

pull down point is set by R_C and

$$R_E: R_C / R_E \cdot \frac{V_{CO}}{2} = 0.7V.$$

MOSFET LIST

In the Table 1, there are some recommended MOSFET for ripple suppressor.

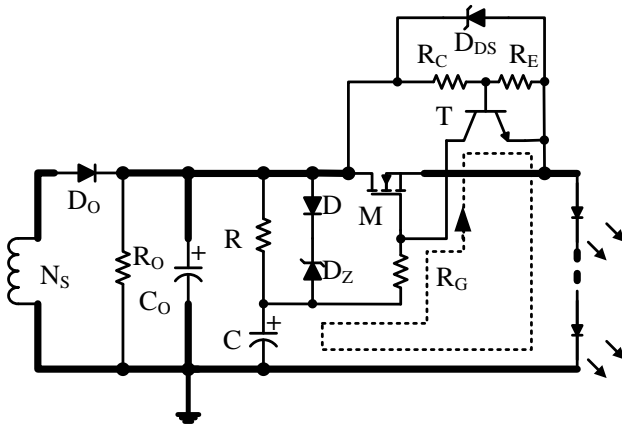

Figure 16: Drain-Source OVP and OCP Circuit

Table 1: MOSFET LIST

| Manufacture P/N | Manufacture | V_{DS}/I_D | $V_{th}(V_{DS}=V_{GS}@T_J=25^\circ C)$ | Power Stage |
|-----------------|-------------|--------------|--|-------------|
| Si4446DY | Vishay | 40V/3A | 0.6-1.6V@ $I_D=250\mu A$ | <10W |
| FTD100N10A | IPS | 100V/17A | 1.0-2.0V@ $I_D=250\mu A$ | 5-15W |
| P6015CDG | NIKO-SEM | 150V/20A | 0.45-1.20V@ $I_D=250\mu A$ | 10-20W |

TYPICAL APPLICATION CIRCUIT

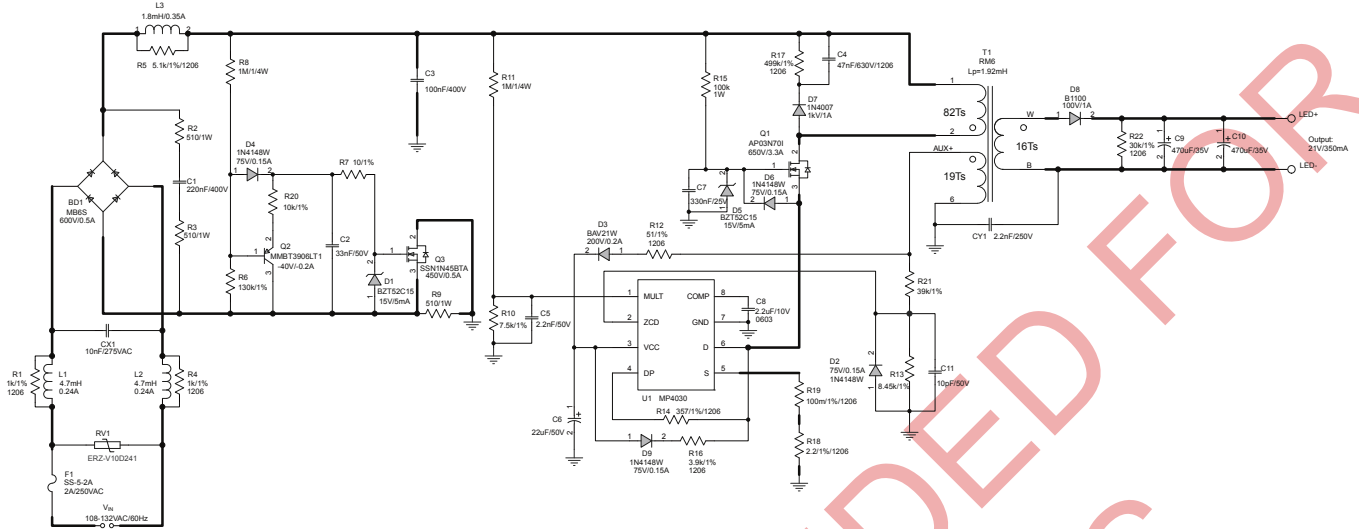

Figure 17: 108-132VAC Input, TRIAC dimmable, Isolated Flyback Converter, Drive 6 LEDs in Series, 350mA LED Current for LED Lighting, EVB Model: EV4030-S-00A

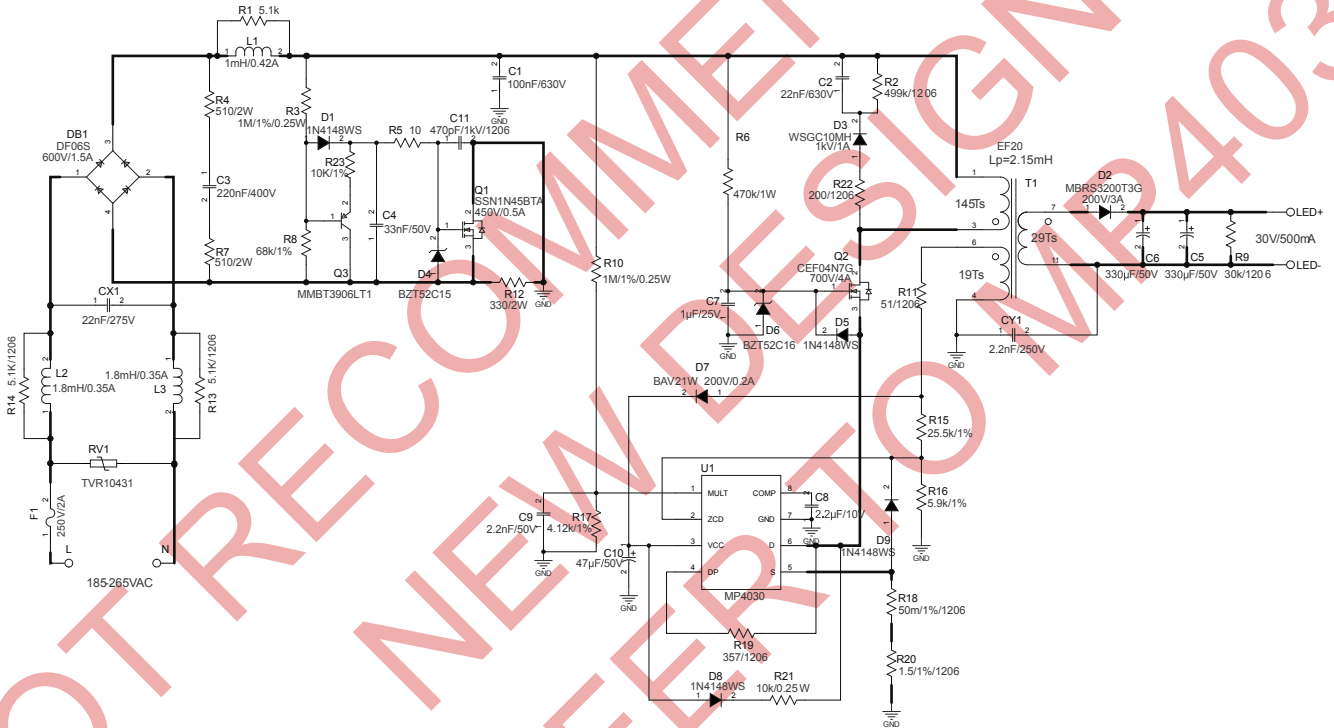

Figure 18: 198-265VAC Input, TRIAC dimmable, Isolated Flyback Converter, Drive 10 LEDs in Series, 530mA LED Current for LED Lighting, EVB Model: EV4030-S-00B

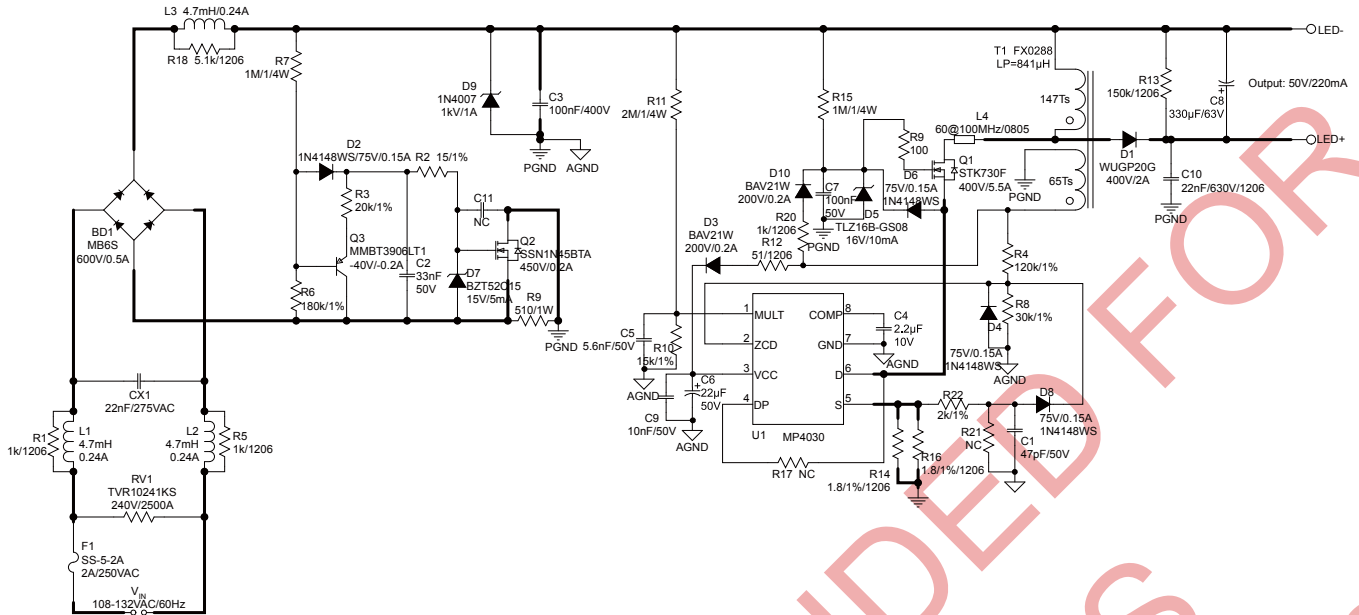

Figure 19: 108-132VAC Input, TRIAC dimmable, Non-isolated Buck-Boost Converter, Drive 16 LEDs in series, 200mA LED Current for LED Lighting, EVB Model: EV4030-S-00C

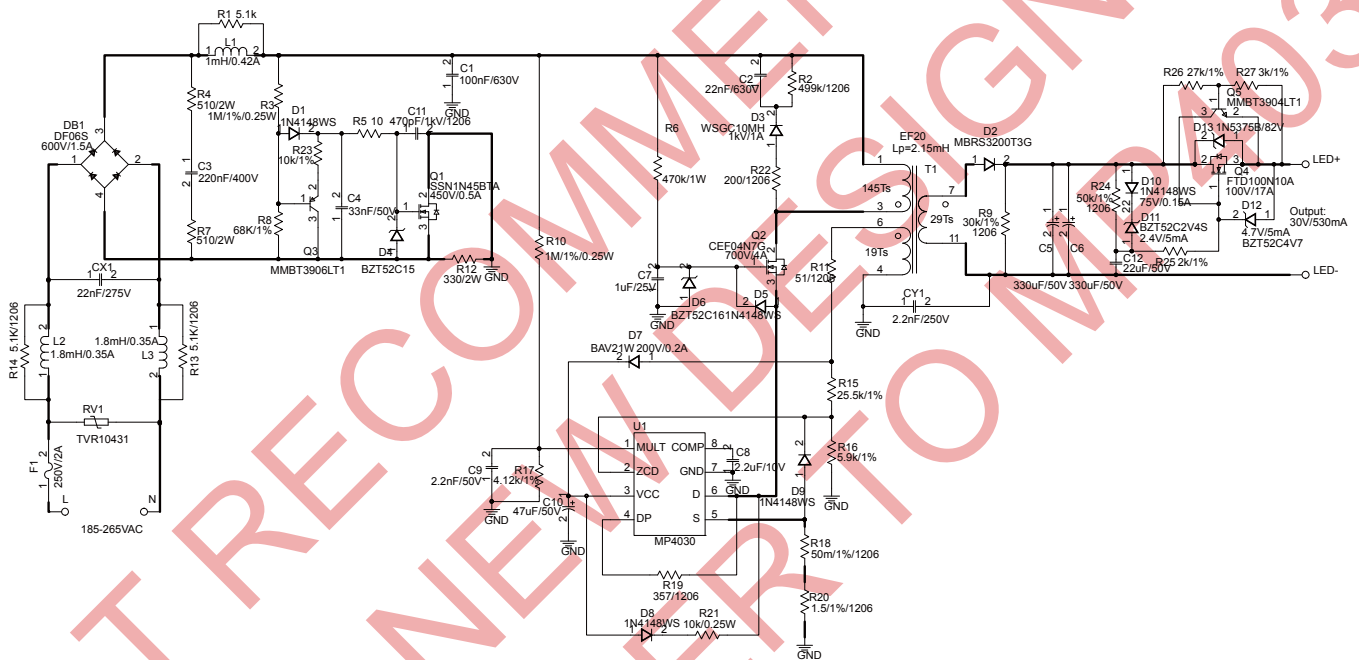
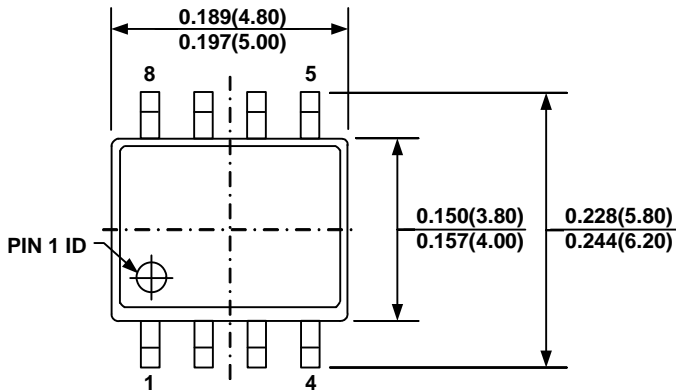
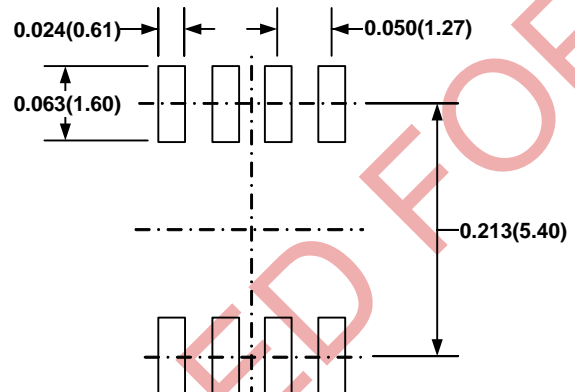
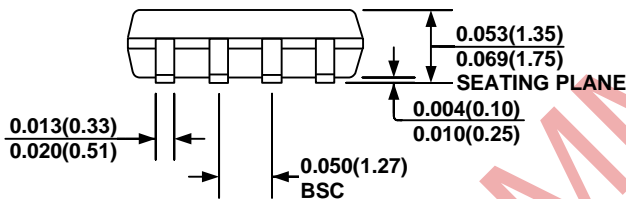
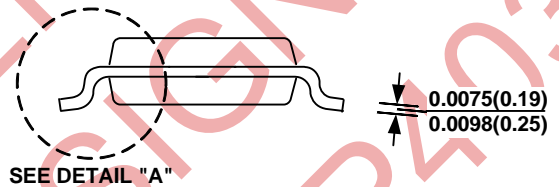
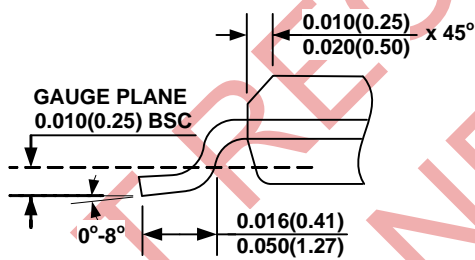

Figure 20: 198-265VAC Input, TRIAC dimmable, Isolated Flyback Converter, Drive 10 LEDs in Series, 530mA LED Current for LED Lighting, output with ripple suppressor

PACKAGE INFORMATION
SOIC8

TOP VIEW

RECOMMENDED LAND PATTERN

FRONT VIEW

SIDE VIEW

DETAIL "A"
NOTE:

- 1) CONTROL DIMENSION IS IN INCHES. DIMENSION IN BRACKET IS IN MILLIMETERS.
- 2) PACKAGE LENGTH DOES NOT INCLUDE MOLD FLASH, PROTRUSIONS OR GATE BURRS.
- 3) PACKAGE WIDTH DOES NOT INCLUDE INTERLEAD FLASH OR PROTRUSIONS.
- 4) LEAD COPLANARITY (BOTTOM OF LEADS AFTER FORMING) SHALL BE 0.004" INCHES MAX.
- 5) DRAWING CONFORMS TO JEDEC MS-012, VARIATION AA.
- 6) DRAWING IS NOT TO SCALE.

NOTICE: The information in this document is subject to change without notice. Users should warrant and guarantee that third party Intellectual Property rights are not infringed upon when integrating MPS products into any application. MPS will not assume any legal responsibility for any said applications.