



MP2884A

Digital, Multi-Phase PWM Controller with PMBus and PWM-VID

DESCRIPTION

The MP2884A is a digital, multi-phase, pulse-width modulation (PWM) controller with digital PWM-VID interface compatible with the Open VReg specification. The MP2884A can work with MPS's Intelli-Phase products to complete the multi-phase voltage regulator (VR) solution with minimal external components. The MP2884A can be configured with up to 4-phase operation.

The MP2884A provides an on-chip EEPROM to store and restore device configurations. Device configurations and fault parameters can be easily programmed or monitored via the PMBus/I²C interface. The MP2884A can monitor and report the output current through the CS output from the Intelli-Phase products.

The MP2884A is based on a unique, digital, multi-phase, non-linear control and provides fast transient response to the load transient with minimal output capacitors. With only one power-loop control method for both steady state and load transient, the power loop compensation is very easy to configure.

The MP2884A is available in a QFN-40 (5mmx5mm) package.

FEATURES

- Programmable Multi-Phase up to Four Phases
- PWM-VID Interface Compatible with Open VReg Specification
- PMBus/I²C Compliant (1MHz Bus Speed)
- Pin Programmable for PMBus Address
- Built-In EEPROM to Store Custom Configurations
- Switching Frequency Range 200kHz to 5MHz
- Automatic Loop Compensation
- Fewer External Components than Conventional Analog Controller
- Best Transient Performance with Non-Linear Digital Control
- Flexible Phase Assignment
- Auto-Phase Shedding to Improve Overall Efficiency
- Phase-to-Phase Active Current Balancing with Programmable Offsets for Thermal Balance
- Output Voltage/Current, Input Voltage/Power Monitoring
- Regulator Temperature Monitoring
- VIN UVLO, Output OVP/UVF, OCP, OTP with No Action, Latch, Retry, or Hiccup Mode Options
- Detecting for Intelli-Phase MOSFET Fault Type and Auto-Record to EEPROM
- Register Map Password Lock
- Digital Load-Line Regulation
- Available in an RoHS Compliant QFN-40 (5mmx5mm) Package

APPLICATIONS

- Graphic Card Core Power
- Server Core Power
- Telecom and Networking Systems
- Base Stations

All MPS parts are lead-free, halogen-free, and adhere to the RoHS directive. For MPS green status, please visit the MPS website under Quality Assurance. "MPS", the MPS logo, and "Simple, Easy Solutions" are trademarks of Monolithic Power Systems, Inc. or its subsidiaries.

TYPICAL APPLICATION

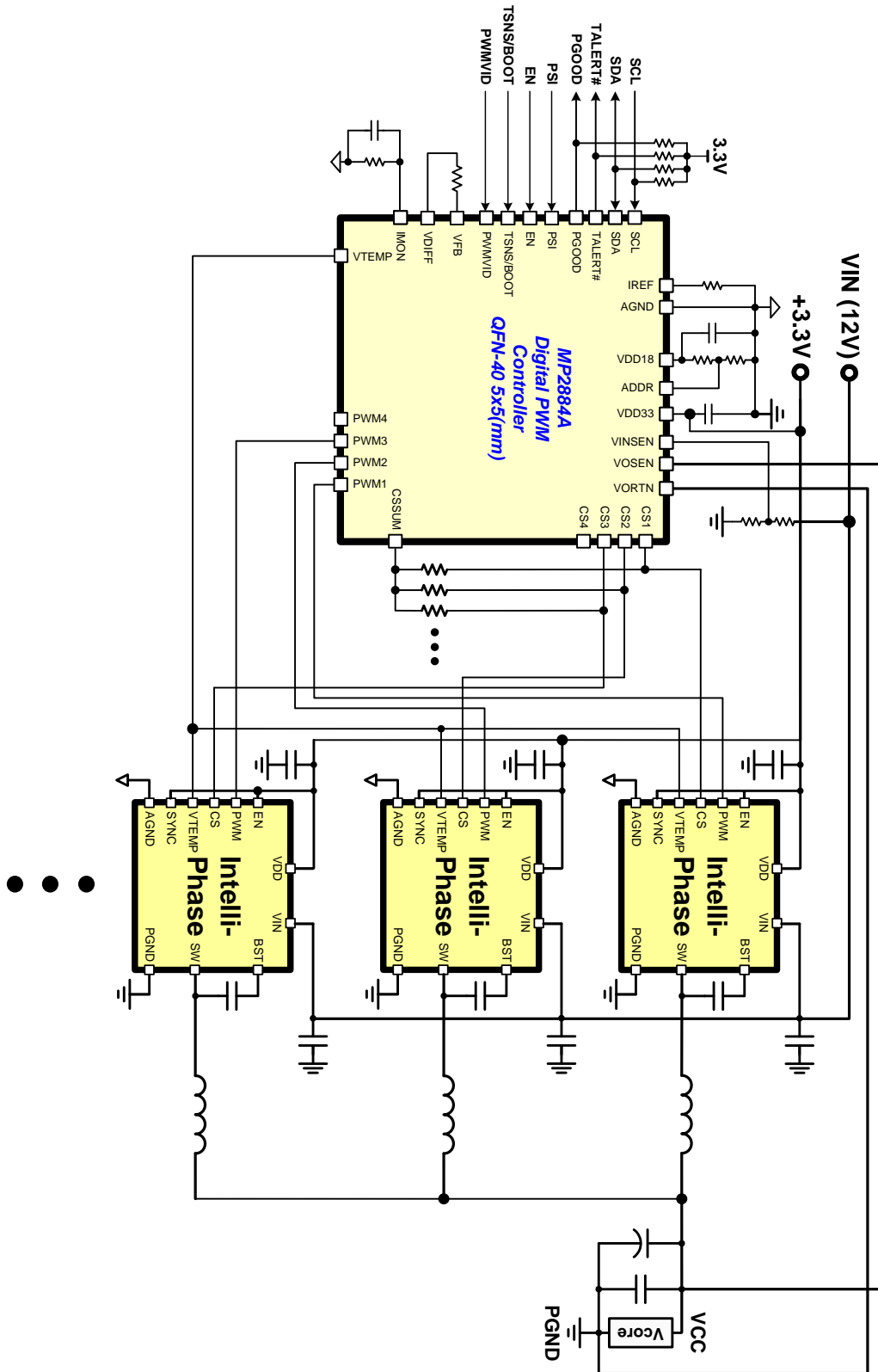

Multi-Phase Application for PWM-VID

ORDERING INFORMATION

Part Number*	Package	Top Marking
MP2884AGU-xxxx**	QFN-40 (5mmx5mm)	See Below

* For Tape & Reel, add suffix -Z (e.g.: MP2884AGU-xxxx-Z).

** "xxxx" is the configuration code identifier for the register settings stored in the EEPROM. Each "x" can be a hexadecimal value between 0 and F. Please work with an MPS FAE to create this unique number.

TOP MARKING

MPSYYWW
MP2884A
LLLLLLL

MPS: MPS prefix
 YY: Year code
 WW: Week code
 MP2884A: Part number
 LLLLLLL: Lot number

PACKAGE REFERENCE

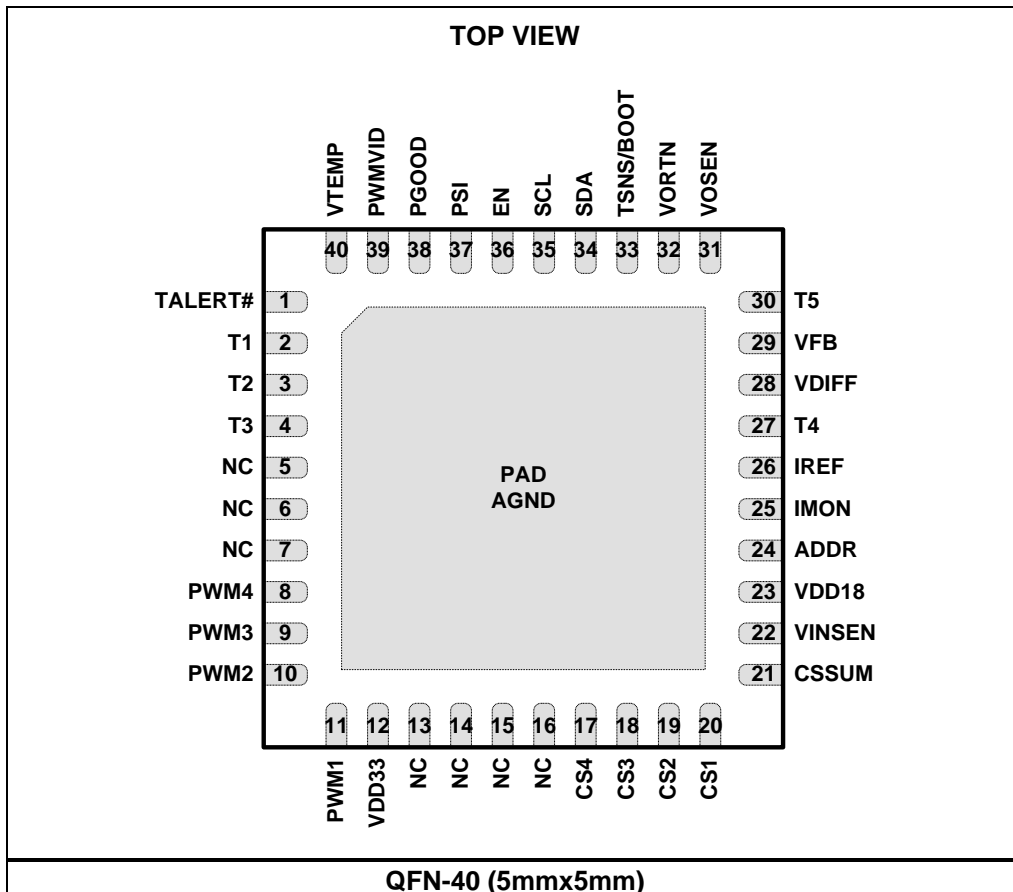

PIN FUNCTIONS

Package Pin #	Name	Type ⁽¹⁾	Description
1	TALERT#	D [O]	Open-drain VR thermal indicator. TALERT# is pulled low if the temperature exceeds the programmed threshold from either VTEMP or TSNS.
2	T1	D [O]	Test pin 1. Leave T1 floating.
3	T2	D [O]	Test pin 2. Leave T2 floating.
4	T3	D [O]	Test pin 3. Leave T3 floating.
5 - 7	NC	D [O]	No connection. Leave NC floating.
8	PWM4	D [O]	Tri-state logic-level PWM outputs. Each output is connected to the PWM input of the Intelli-Phase. The low logic level is 0V. The high logic level is 3.3V. The mid-state logic level is 1.5V (or high impedance). Float PWMx if it is not being used.
9	PWM3	D [O]	
10	PWM2	D [O]	
11	PWM1	D [O]	
12	VDD33	Power	3.3V power supply input. Connect a 1 μ F bypass capacitor from VDD33 to AGND.
13 - 16	NC	A [I]	No connection. Leave NC floating.
17	CS4	A [I]	Phase 1~4 current sense input. Short CSx to AGND or CSSUM if it is not being used.
18	CS3	A [I]	
19	CS2	A [I]	
20	CS1	A [I]	
21	CSSUM	A [I]	Total phase current sensing input. CSSUM is used for load-line and over-current protections. Connect the active phases' CS signals together to CSSUM through the current-sense resistors.
22	VINSEN	A [I]	Input voltage sensing. Place a resistor divider from the power stage (V_{IN}) to VINSEN.
23	VDD18	Power	1.8V LDO output. VDD18 provides a power supply for the internal digital circuit. Connect a 1 μ F bypass capacitor from VDD18 to AGND.
24	ADDR	A [I]	PMBus address setting.
25	IMON	A [I/O]	Analog total average current sensing signal. IMON sources a current proportional to the sensed total average current from CSSUM. IMON is used for load-current reporting.
26	IREF	A [I/O]	Internal bias current set. Connect a 61.9k Ω , 1% accuracy resistor from IREF to AGND.
27	T4	A [I]	Test pin 4. Short T4 to AGND.
28	VDIFF	A [O]	Output of the differential remote sense amplifier.
29	VFB	A [I/O]	Feedback. VFB sources a current (I_{droop}) proportional to the sensed output current. This current flows through the resistor (R_{droop}) between VFB and VDIFF to create a voltage drop proportional to the load current to achieve the load-line function.
30	T5	A [I]	Test pin 5. Short T5 to AGND.
31	VOSEN	A [I]	Remote voltage sensing positive input. VOSEN is connected to the VR output voltage directly at the load. Route VOSEN with VORTN differentially.
32	VORTN	A [I]	Remote voltage sensing return input. VORTN is connected to the ground directly at the load. Route VORTN with VOSEN differentially.

PIN FUNCTIONS (continued)

Package Pin #	Name	Type ⁽¹⁾	Description
33	TSNS/BOOT	A [I/O]	Thermistor thermal sensing input or boot voltage setting. TSNS/BOOT can be programmed for either thermistor thermal sensing or boot voltage setting. When used as TSNS, the controller compares the voltage of TSNS/BOOT to an internal programmable threshold. Once triggered, TALERT# is asserted, and the VR enters a pre-programmed protection mode. When used as BOOT, a voltage divider is required from VDD18 to TSNS/BOOT to set the boot voltage.
34	SDA	D [I/O]	PMBus data.
35	SCL	D [I]	PMBus clock.
36	EN	D [I]	Enable control.
37	PSI	A [I]	Power saving interface. 1.8V logic. When PSI is 1, all phases have forced continuous conduction mode (CCM). When PSI is 0, there is an adjustable low-phase count. When PSI is in Hi-Z, auto-phase-shedding is enabled.
38	PGOOD	D [O]	Power good indication. PGOOD is an open-drain output. PGOOD asserts when the output voltage is in regulation.
39	PWMVID	A [I]	PWM-VID signal input. PWMVID is a 1.8V logic. Connect the PWM-VID signal to PWMVID. The VR calculates the target VID based on the duty.
40	VTEMP	A [I]	Analog signal from the VR to the controller. VTEMP indicates the maximum temperature of the power stages. The MP2884A supports temperature sensing from the Intelli-Phase power stages. Tie all temperature reporting pins from the Intelli-Phase together to produce the maximum value on the VTEMP bus.
PAD	AGND	Power	Analog ground.

NOTE:

1) A = analog, D = digital, I = input, O = output, I/O = bidirectional.

ABSOLUTE MAXIMUM RATINGS ⁽²⁾

VDD33	-0.3V to +4.0V
VDD18	-0.3V to +2.0V
CS1~4, PWM1~4, VFB, VDIFF, VOSEN, VORTN, PGOOD, PSI, SCL, SDA, TSNS/BOOT, TALERT#, PWMVID, EN, VTEMP	-0.3V to +4.0V
CSSUM, IMON, IREF, VINSEN, ADDR	-0.3V to +2.0V
Junction temperature	150°C
Lead temperature	260°C
Continuous power dissipation ⁽³⁾	3.47W

Recommended Operating Conditions ⁽⁴⁾

Supply voltage (V _{IN})	+3.0V to 3.6V
Operating junction temp. (T _J) ...	-40°C to +125°C

Thermal Resistance ⁽⁵⁾	θ_{JA}	θ_{JC}
QFN-40 (5mmx5mm)	36	5

NOTES:

- Exceeding these ratings may damage the device.
- The maximum allowable power dissipation is a function of the maximum junction temperature T_J (MAX), the junction-to-ambient thermal resistance θ_{JA}, and the ambient temperature T_A. The maximum allowable continuous power dissipation at any ambient temperature is calculated by P_D (MAX) = (T_J (MAX) - T_A) / θ_{JA}. Exceeding the maximum allowable power dissipation produces an excessive die temperature.
- The device is not guaranteed to function outside of its operating conditions.
- Measured on JESD51-7, 6-layer PCB.

ELECTRICAL CHARACTERISTICS

VDD33 = 3.3V, EN = 1V, current going into the pin is positive. Typical values are at T_A = 25°C.

Parameter	Symbol	Condition	Min	Typ	Max	Units
Remote Sense Amplifier						
Bandwidth ⁽⁶⁾	GBW _(RSA)			20		MHz
VORTN current	I _{VORTN}	EN = 1V, VOSEN = 3V, VORTN = 0V		-38		μA
VOSEN current	I _{VOSEN}	EN = 1V, VOSEN = 3V, VORTN = 0V		38		μA
Oscillator						
Frequency	f _{OSC}	V _{IREF} = 1.23V, R _{IREF} = 61.9kΩ		1.56		MHz
System Interface Control Inputs						
Enable (EN)						
Input low voltage	V _{IL(EN)}				0.4	V
Input high voltage	V _{IH(EN)}		0.8			V
Enable high leakage	I _{IH(EN)}	EN = 2V			2.3	μA
IMON Output						
Current gain	I _{MON} /I _{CS_SUM}	Measured from I _{CS_SUM} to I _{MON} , I _{CS_SUM} = -2mA		1:16		μA/μA
Current gain accuracy			-1		1	%
PWM-VID						
Input low voltage	PWM _{VIDL}				0.4	V
Input mid-state	PWM _{HIZ}			0.9		V
Input high voltage	PWM _{VIDH}		1.4			V
PSI						
Input low voltage	PSI _L				0.4	V
Input mid-state	PSI _M			0.9		V
Input high voltage	PSI _H		1.4			V
PWM Outputs						
Output low voltage	V _{OL (PWM)}	I _{PWM(SINK)} = 400μA		10	200	mV
Output middle voltage	V _{OM (PWM)}	I _{PWM(SOURCE)} = -100μA		1.36		V
Output high voltage	V _{OH (PWM)}	I _{PWM(SOURCE)} = -400μA	3.15	VDD33 -0.02		V
Rise and fall time ⁽⁶⁾		C = 10pF		10		ns
PWM tri-state leakage		PWM = 1.5V, EN = 0V	-1		1	μA
PWM fault detection source current ⁽⁶⁾	I _{source(PWM)}	Enter PWM fault detect mode		150		μA
TSNS						
Current source	I _{TSNS}			10		μA

ELECTRICAL CHARACTERISTICS (continued)

 VDD33 = 3.3V, EN = 1V, current going into the pin is positive. Typical values are at T_A = 25°C.

Parameter	Symbol	Condition	Min	Typ	Max	Units
Comparator (Protection)						
Under-voltage threshold		Relative to reference DAC voltage (2Ch bit[2:0] = 3b'001)		-190		mV
		Relative to reference DAC voltage (2Ch bit[2:0] = 3b'010)		-310		mV
		Relative to reference DAC voltage (2Ch bit[2:0] = 3b'100)		-430		mV
Over-voltage threshold		Relative to reference DAC voltage (2Ch bit[2:0] = 3b'001)		190		mV
		Relative to reference DAC voltage (2Ch bit[2:0] = 3b'010)		310		mV
		Relative to reference DAC voltage (2Ch bit[2:0] = 3b'100)		430		mV
VDD33 Supply						
Supply voltage range	VDD33		3.0	3.3	3.6	V
Supply current	I _{VDD33}	EN = high or programmed as non-low-power mode		30		mA
		EN = 0 and programmed as low-power mode		150		μA
UVLO threshold voltage	VDD33 _{UVLO}	VDD33 is rising		2.88	2.98	V
	VDD33 _{UVLO}	VDD33 is falling	2.68	2.80		V
1.8V Regulator						
1.8V regulator output voltage	VDD18	I _{VDD18} = 0mA		1.8		V
1.8v regulator load capability	I _{VDD18}	VOL = VDD18 - 40mV		30		mA
ADC						
ADC voltage reference			1.592	1.6	1.608	V
ADC resolution ⁽⁶⁾				10		bits
DNL ⁽⁶⁾					1	LSB
Sample rate ⁽⁶⁾				700		kHz
DAC (Reference Voltage)						
DAC voltage reference	FS _{ADC}			1.7		V
Resolution/LSB	Δ _{ADC}			6.25		mV
Max output voltage slew rate ⁽⁶⁾				50		mV/μs
OC_DAC (Protection)						
Range ⁽⁶⁾	FS _{DAC_PRT}	Adjustable via the PMBus	0.17		2.72	V
Resolution/LSB ⁽⁶⁾	Δ _{DAC_PRT}			10		mV

ELECTRICAL CHARACTERISTICS (continued)

 VDD33 = 3.3V, EN = 1V, current going into the pin is positive. Typical values are at T_A = 25°C.

Parameter	Symbol	Condition	Min	Typ	Max	Units
PMBus DC Characteristics (SDA, SCL)						
Input high voltage	V _{IH}		1.35			V
Input low voltage	V _{IL}				0.8	V
Input leakage current			-10		10	μA
Pin capacitance ⁽⁶⁾	C _{PIN}				10	pF
PMBus Timing Characteristics (1MHz) ⁽⁷⁾						
Operating frequency range			10		1000	kHz
Bus free time		Between stop and start condition	0.5			μs
Holding time			0.26			μs
Repeated start condition set-up time			0.26			μs
Stop condition set-up time			0.26			μs
Data hold time			0			ns
Data set-up time			50			ns
Clock low time-out			25		35	ms
Clock low period			0.5			μs
Clock high period			0.26		50	μs
Clock/data fall time					120	ns
Clock/data rise time					120	ns

NOTE:

- 6) Guaranteed by design or characterization data, not tested in production.
 7) The device supports 100kHz, 400kHz, and 1MHz bus speeds. The PMBus timing parameters in this table is for operation at 1MHz. If the PMBus operating frequency is 100kHz or 400kHz, refer to the SMBus specification for timing parameters.

TYPICAL PERFORMANCE CHARACTERISTICS

$V_{IN} = 12V$, $C_{OUT} = 6400\mu F$, $R_{IMON} = 4.42k\Omega$, PGOOD is pulled up to +3.3V. $T_A = +25^\circ C$, unless otherwise noted.

Steady State

$V_{IN} = 12V$, $V_{DD1} = 0.8V$, $F_{SW} = 500kHz$,
4-phase CCM, $I_{OUT} = 0A$

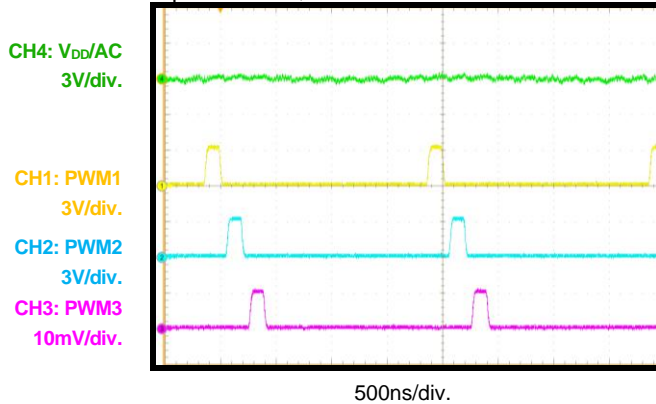

Steady State

$V_{IN} = 12V$, $V_{DD} = 0.8V$, $F_{SW} = 500kHz$,
4-phase CCM, $I_{OUT} = 60A$

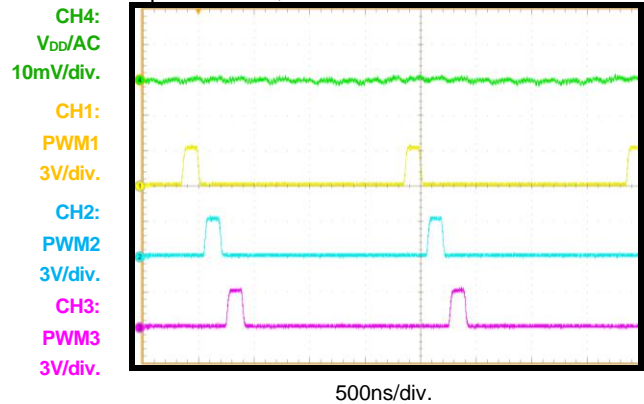

EN Power On

$V_{IN} = 12V$, $V_{BOOST} = 0.8V$, RC slew rate,
 $T_{AU} = 163.84\mu s$

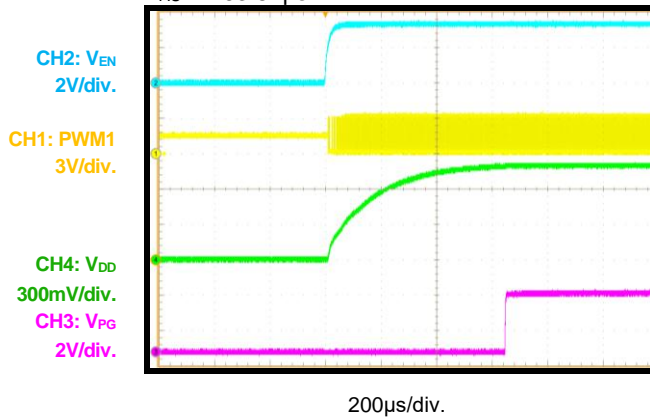

EN Soft Off

$V_{IN} = 12V$, $V_{BOOST} = 0.8V$, RC slew rate,
 $T_{AU} = 163.84\mu s$

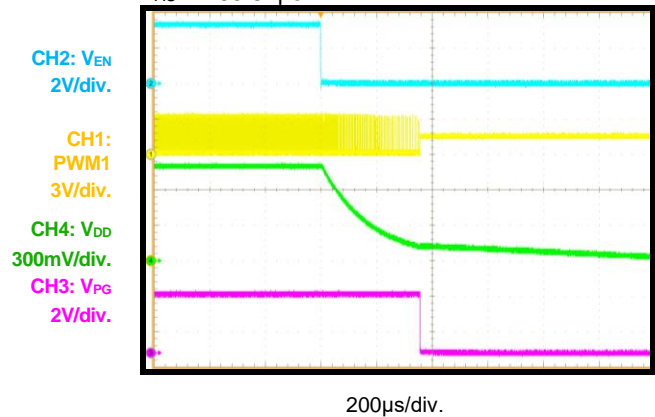

EN Power On

$V_{IN} = 12V$, $V_{BOOST} = 0.8V$, linear slew rate,
 $SR = 1.98mV/\mu s$

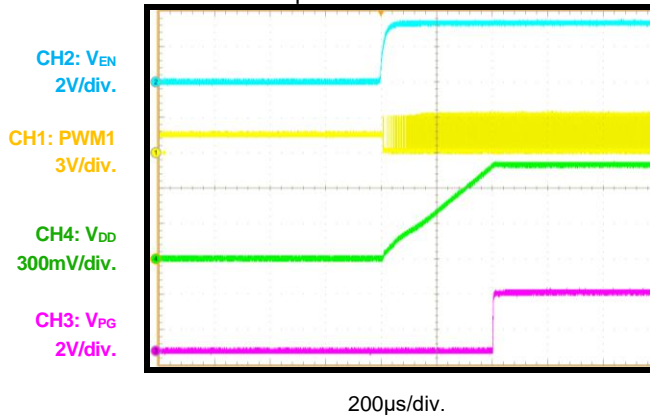

EN Soft Off

$V_{IN} = 12V$, $V_{BOOST} = 0.8V$, linear slew rate,
 $SR = 1.98mV/\mu s$

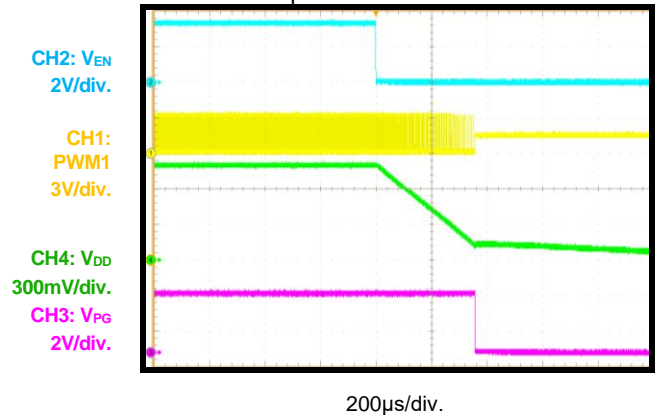

TYPICAL PERFORMANCE CHARACTERISTICS (continued)

$V_{IN} = 12V$, $C_{OUT} = 6400\mu F$, $R_{IMON} = 4.42k\Omega$, PGOOD is pulled up to +3.3V. $T_A = +25^\circ C$, unless otherwise noted.

DVID Up

DVID from 0.4V to 1.2V, RC slew rate,
 $T_{AU} = 18.2\mu s$

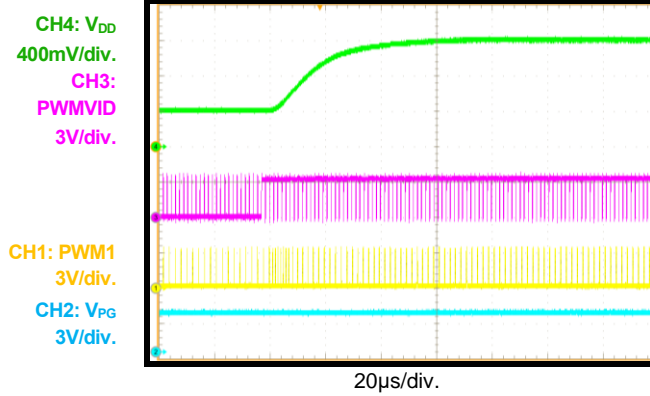
DVID Down

DVID from 1.2V to 0.4V, RC slew rate,
 $T_{AU} = 18.2\mu s$

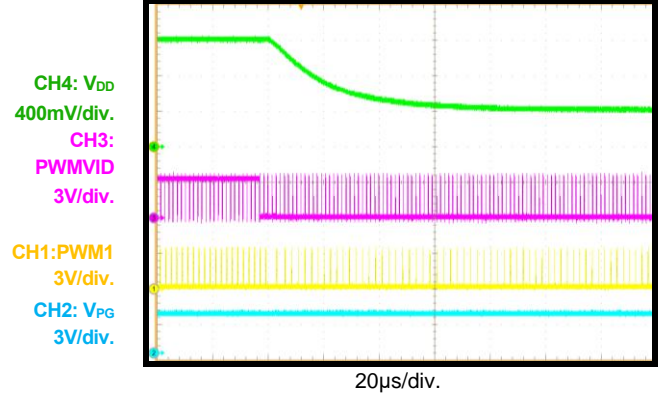
DVID Up

DVID from 0.4V to 1.2V, linear slew rate,
 $SR = 9.62mV/\mu s$

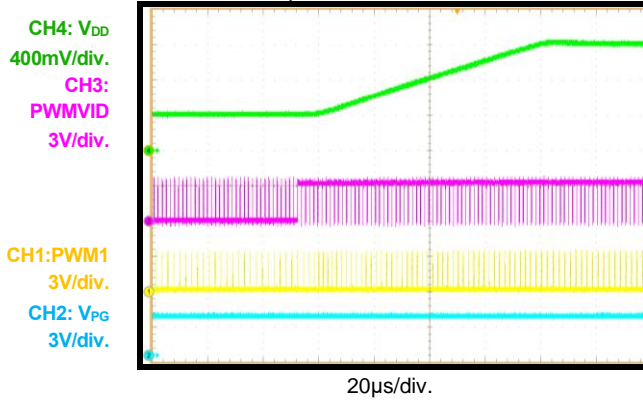
DVID Down

DVID from 1.2V to 0.4V, linear slew rate,
 $SR = 9.62mV/\mu s$

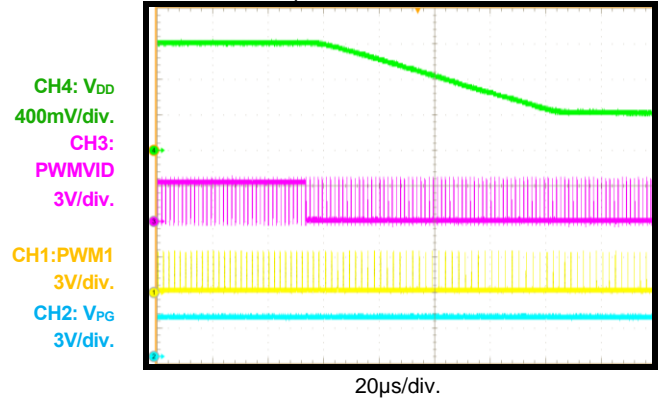
Load Transient with DC Load Line

$V_{IN} = 12V$, $V_{DD} = 1V$, $F_{SW} = 500kHz$,
 $R_{LL} = 0.5m\Omega$, $I_{OUT} = 0 \leftrightarrow 150A @ 500A/\mu s$

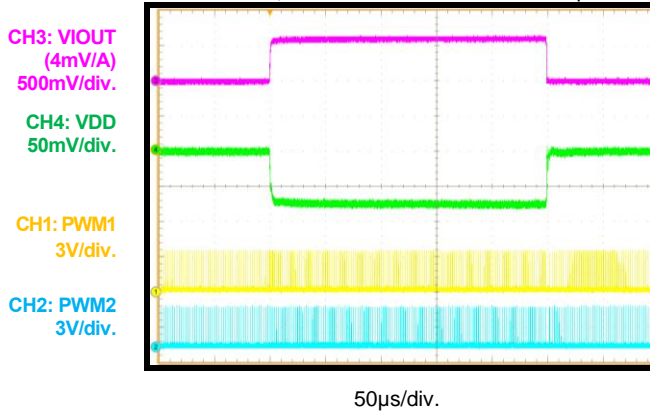
Load Transient with AC Load Line

$V_{IN} = 12V$, $V_{DD} = 1V$, $F_{SW} = 500kHz$,
 $R_{LL} = 0m\Omega$, $I_{OUT} = 0 \leftrightarrow 150A @ 500A/\mu s$

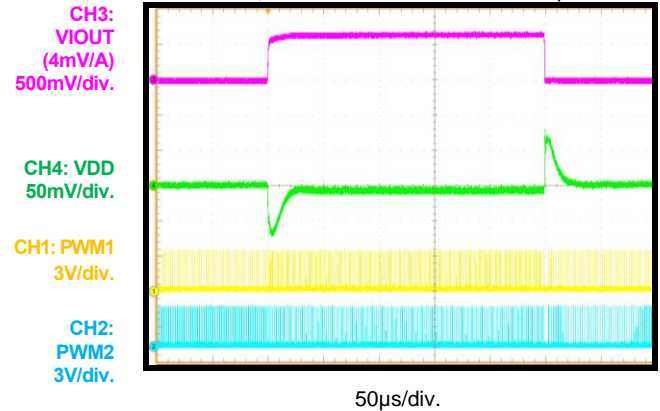

TYPICAL PERFORMANCE CHARACTERISTICS (continued)

$V_{IN} = 12V$, $C_{OUT} = 6400\mu F$, $R_{IMON} = 4.42k\Omega$, PGOOD is pulled up to +3.3V. $T_A = +25^\circ C$, unless otherwise noted.

PSI Changes between High- and Middle-State

Enable APS, low phase count = 1, $I_{OUT} = 20A$
(2-phase running according to APS levels)

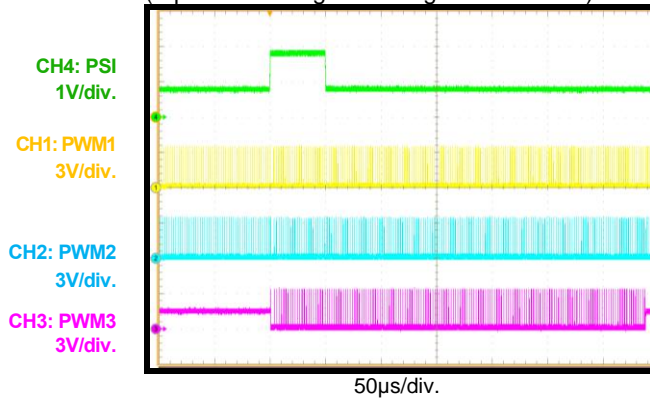
PSI Changes between High and Low

Enable APS, low phase count = 1, $I_{OUT} = 20A$
(2-phase running according to APS levels)

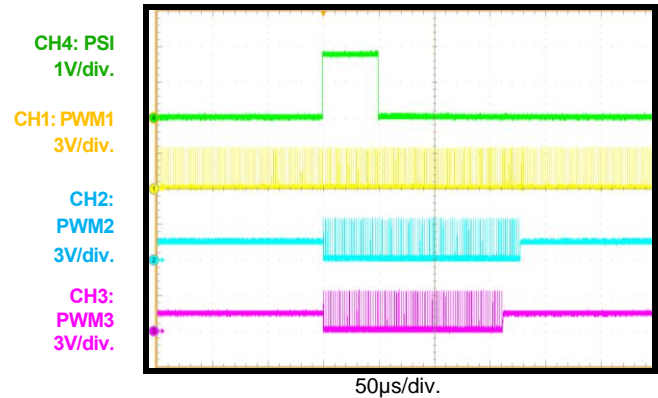
OVP

$V_{IN} = 12V$, $V_{DD} = 1V$, OVP delay time = 0.5µs,
latch-off mode

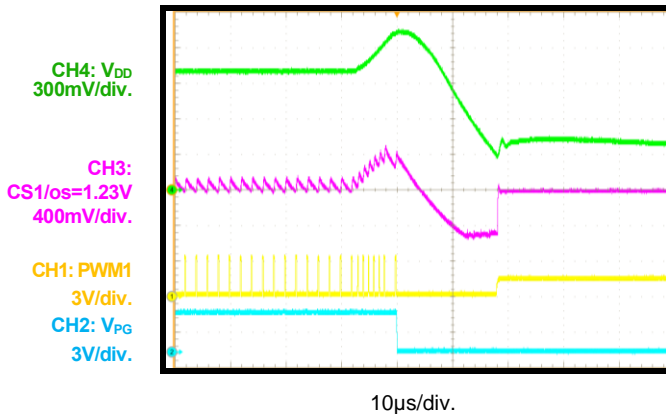
UVP

$V_{IN} = 12V$, $V_{DD} = 1V$, UVP delay time = 400µs,
latch-off mode

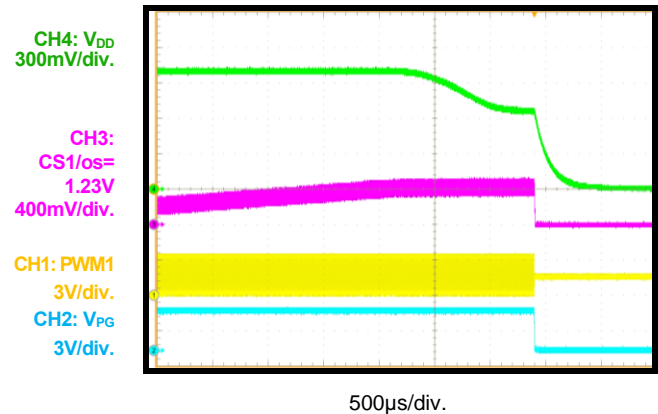
OCP

$V_{IN} = 12V$, $V_{DD} = 1V$, OCP threshold = 500A,
check time = 200µs, latch-off mode

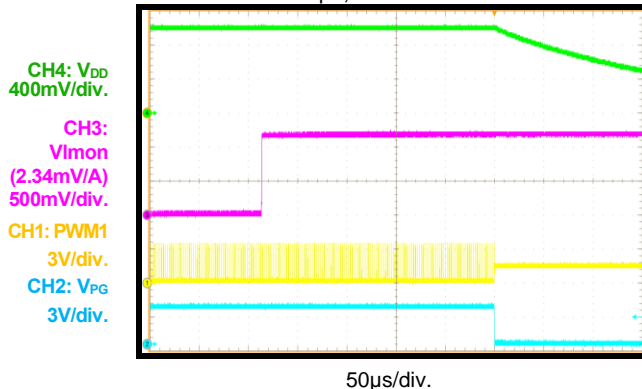
OTP

$V_{IN} = 12V$, $V_{DD} = 1V$, $T_J = (100^\circ C/V) * V_{TEMP} + 10^\circ C$, OTP threshold = 120°C, latch-off mode

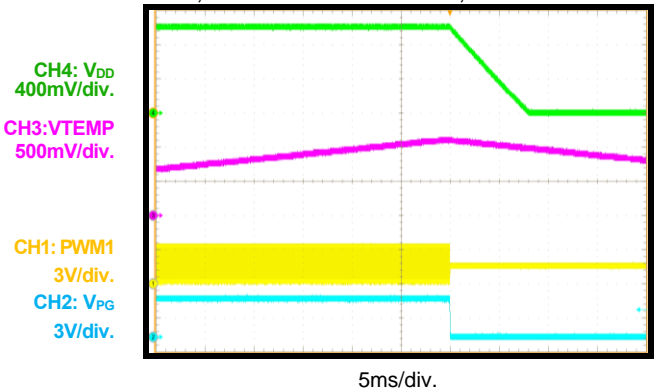

BLOCK DIAGRAM

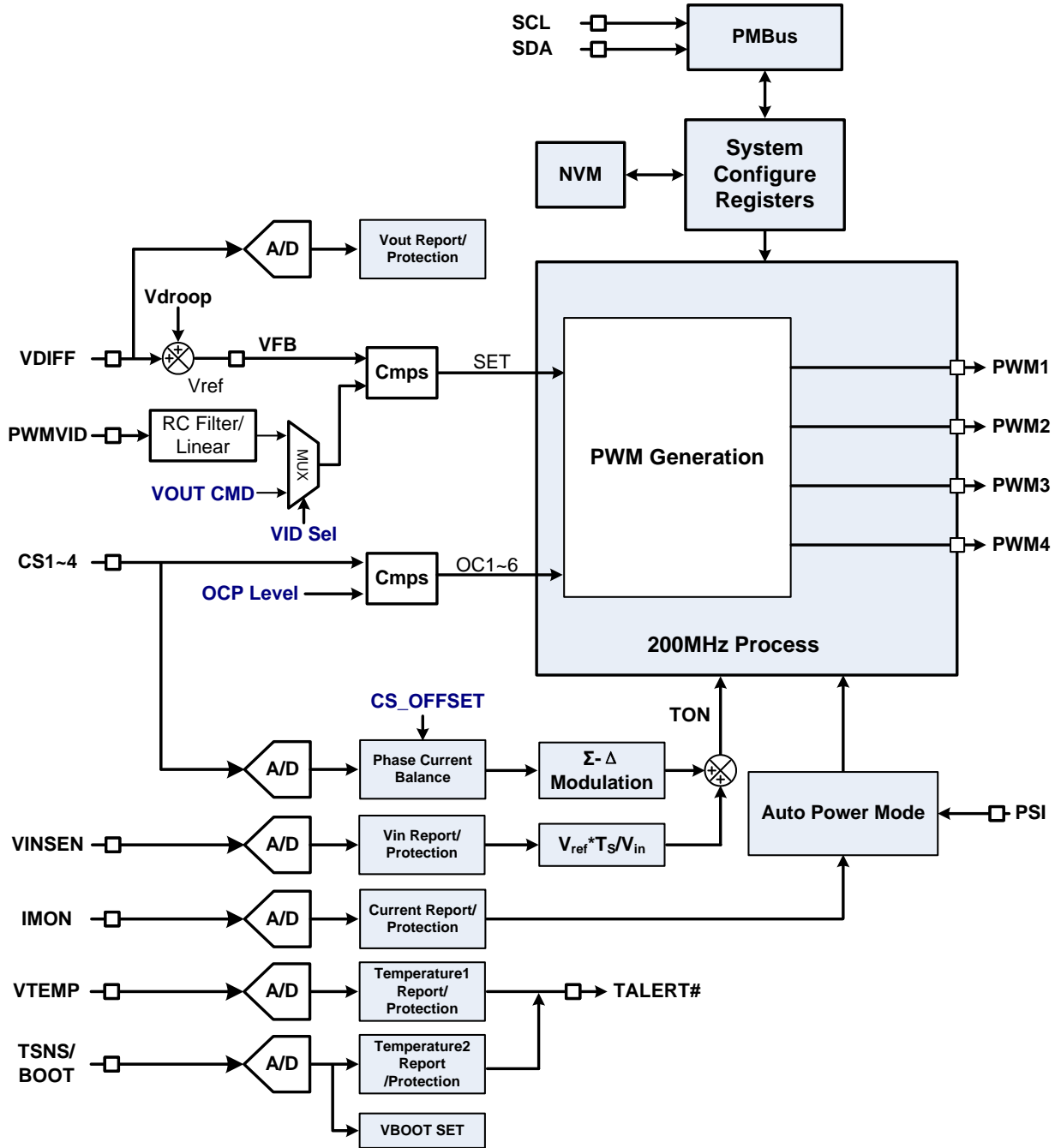

Figure 1: System Functional Block

Where V_{OUT} is the real-time output voltage reference, V_{IN} is the input voltage, and F_S is the switching frequency set by the PMBus.

Voltage Reference

The MP2884A has an 8-bit VID-DAC, which provides the reference voltage (V_{REF}) for the individual output. V_{REF} is in a VID format with 6.25mV per step. The relationship between V_{REF} and the VID value in decimals is shown in Equation (2):

$$V_{REF}(V) = VID \times 0.000625 \quad (2)$$

When setting the unit gain for the differential voltage sense amplifier and VID is higher than 256, V_{REF} is limited to 1.6V.

When setting the half gain for the differential voltage sense amplifier, V_{REF} can range from 0 ~ 3.19375V.

Output Voltage Setting and Sensing

In PMBus-VID control mode, the desired output voltage can be set by the PMBus command VOUT_COMMAND (21h). VOUT_COMMAND (21h) is a 9-bit register in a VID format with 6.25mV per step. The output setting range is 0 ~ 3.19375V.

In PWM-VID control mode, the desired output voltage can be set according to Equation (3):

$$VID = (VID_{MAX} - VID_{MIN}) \times D_{PWMVID} + VID_{MIN} \quad (3)$$

Where VID_{MAX} is the maximum voltage setting, VID_{MIN} is the minimum voltage setting, and D_{PWMVID} is the duty of the PWM-VID signal.

The voltage at the load is sensed with the differential voltage sense amplifier. This type of sensing provides better load regulation.

The MP2884A provides high-resolution trimming and digital DC calibration for high output voltage regulation accuracy. With a unit gain of the differential voltage amplifier, the V_{OUT} regulation accuracy is within $\pm 1.5625mV$. With a half-gain of the differential voltage amplifier, the V_{OUT} regulation accuracy is within $\pm 3.125mV$.

Active Voltage Positioning (AVP)

The MP2884A supports active voltage positioning (AVP) by connecting a droop resistor (R_{DROOP}) between VDIFF and VFB. With this function, the output voltage drops gradually as the load current increases. This is also known as load-line regulation. The relationship of the output voltage and load current is shown in Equation (4):

$$V_{OUT@IOUT} = V_{OUT@NO\ LOAD} - I_{OUT} \times R_{LL} \quad (4)$$

Where R_{LL} is the equivalent load-line resistor.

The MP2884A provides a PMBus-programmable load line. The final load-line value is determined by R_{DROOP} and the value in the register IDROOP_SET (1Eh). The load-line calculation is shown in Equation (5):

$$R_{LL} = \left(\frac{IDROOP_SET + 4}{64} \right) \times K_{CS} \times R_{DROOP} \quad (5)$$

Where IDROOP_SET is the value in register MFR_IDROOP_CTRL (1Eh), and K_{CS} is the current sense gain of the power stage.

IDROOP_SET ranges from 1 ~ 15. When setting IDROOP_SET = 0, the AVP function is disabled.

When setting a half-gain for the differential voltage sense amplifier, the R_{LL} value in Equation (5) should be doubled.

For non-AVP VR applications, it is recommended to enable the AC droop function via register AC_DROOP_EN (1Eh) to increase the phase margin of the loop regulation. The AC droop function can inject the AC current of the total inductor current to R_{DROOP} to introduce the current ripple signal to the loop regulation.

Boot Voltage Setting

In PMBus-VID control mode, the MP2884A can pre-program the boot voltage (V_{BOOT}) either by register VOUT_COMMAND (21h) or by TSNS/BOOT. Figure 3 shows the connection for the pin-programmed V_{BOOT} .

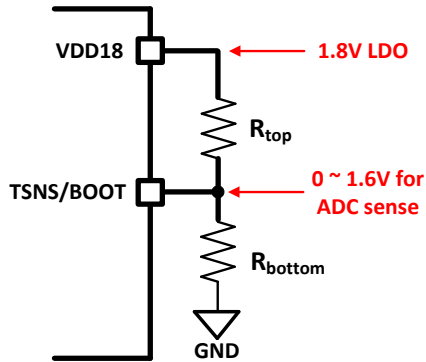

Figure 3: Circuit of Pin-Strap Boot Voltage

Table 1a and Table 1B show four options for the TSNS/BOOT pin-programmed V_{BOOT} .

Table 1: Pin-Strap Boot Voltage Table 1

TSNS/BOOT Voltage Point (V)	Boot Voltage (V) (0.1V/step) 45h bit[1:0] = 00	Boot Voltage (V) (0.2V/step) 45h bit[1:0] = 10
0.05	0	0
0.15	0.1	0.2
0.25	0.2	0.4
0.35	0.3	0.6
0.45	0.4	0.8
0.55	0.5	1
0.65	0.6	1.2
0.75	0.7	1.4
0.85	0.8	1.6
0.95	0.9	1.8
1.05	1	2
1.15	1.1	2.2
1.25	1.2	2.4
1.35	1.3	2.6
1.45	1.4	2.8
1.55	1.5	3

The boot-up linear slew rate is set via register MFR_BOOT_SR (B9h) and ranges from 0.12 - 125mV/ μ s, as shown in Equation (6):

$$\text{SlewRate} = \frac{6.25\text{mV}}{\text{MFR_BOOT_SR} \times 0.05\mu\text{s}} \quad (6)$$

In PWM-VID control mode, V_{BOOT} can only be set by the register MFR_VBOOT (BBh). When PWM-VID is in mid-state, the VR output slews to the boot voltage.

There are two boot-up slewing modes for PWM-VID control mode: R-C filter mode and linear mode.

Table 1b: Pin-Strap Boot Voltage Table 2

TSNS/BOOT Voltage Point (V)	Boot Voltage (V) (0.05V/step) 45h bit[1:0] = 01	Boot Voltage (V) (0.1V/step) 45h bit[1:0] = 11
0.025	0	0
0.075	0.05	0.1
0.125	0.1	0.2
0.175	0.15	0.3
0.225	0.2	0.4
0.275	0.25	0.5
0.325	0.3	0.6
0.375	0.35	0.7
0.425	0.4	0.8
0.475	0.45	0.9
0.525	0.5	1
0.575	0.55	1.1
0.625	0.6	1.2
0.675	0.65	1.3
0.725	0.7	1.4
0.775	0.75	1.5
0.825	0.8	1.6
0.875	0.85	1.7
0.925	0.9	1.8
0.975	0.95	1.9
1.025	1	2
1.075	1.05	2.1
1.125	1.1	2.2
1.175	1.15	2.3
1.225	1.2	2.4
1.275	1.25	2.5
1.325	1.3	2.6
1.375	1.35	2.7
1.425	1.4	2.8
1.475	1.45	2.9
1.525	1.5	3
1.575	1.55	3.1

The boot-up R-C filter time constant is set with register MFR_PARM_RC_CONST (B5h) and ranges from 10.40 - 655.36 μ s, as shown in Equation (7):

$$\tau_{RC} (\mu\text{s}) = \frac{0.32\mu\text{s}}{\text{BOOT_RC}} \times 2^{11} \quad (7)$$

Where BOOT_RC is the value in register MFR_PARM_RC_CONST (B5h).

The boot-up linear slew rate is set with register MFR_BOOT_SR (B9h) and ranges from 0.12 - 125mV/ μ s (see Equation (6)).

Dynamic Voltage Identification (DVID)

The MP2884A supports dynamical output voltage transition by changing VID via the PMBus commands or the duty of the PWM-VID signal.

The DVID process is active after V_{OUT} is settled and can be either upward or downward.

In PMBus-VID control mode, the DVID linear slew rate is set with register MFR_DVID_SR (BAh) and ranges from 0.12 - 125mV/ μ s, as shown in Equation (8):

$$\text{SlewRate} = \frac{6.25\text{mV}}{\text{MFR_DVID_SR} \times 0.05\mu\text{s}} \quad (8)$$

There are two slew rate modes in PWM-VID control mode: R-C filter mode and linear mode.

The DVID R-C filter slew rate is set with register MFR_PARM_RC_CONST (B5h) and ranges from 10.40 - 655.36 μ s, as shown in Equation (9):

$$\tau_{RC} (\mu\text{s}) = \frac{0.32\mu\text{s}}{\text{DVID_RC}} \times 2^{11} \quad (9)$$

Where DVID_RC is the value in register MFR_PARM_RC_CONST (B5h).

The DVID linear slew rate is set with register MFR_DVID_SR (BAh) and ranges from 0.12 - 125mV/ μ s (see Equation (8)).

VID Offset

The MP2884A supports two types of VID offset.

The first type is VID step offset, which ranges from -0.69375V to 0.7V with 6.25mV of resolution. When the PMBus writes a new offset to register VOUT_OFFSET (23h), the VR ramps with the slew rate shown in Equation (8).

The second type is fine-tune offset for the VID set point, which ranges from -31.5mV to 31.5mV with 0.5mV of resolution at a unity gain of the differential voltage sense amplifier and ranges from -50.4mV to 50.4mV with 0.8mV of resolution at a half-gain of differential voltage sense amplifier. Refer to the register map MFR_RSAMP_OFFSET (2Dh) section on page 44 for details.

Inductor Current Sensing

The MP2884A works with the Intelli-Phase for inductor current sensing (see Figure 4). The voltage on CSs is sampled, calculated, and stored in the registers. The results are used for multi-phase current balancing and thermal balancing and can be monitored via the PMBus.

The MP2884A provides cycle-by-cycle per-phase current limitation.

The resistor (R_{CS}) is connected from CSx to CSSUM. CSSUM is a 1.23V constant voltage and can sink or source current to provide voltage shifts that meet the operating voltage range of CSs.

Short any unused CSx pin to AGND or CSSUM.

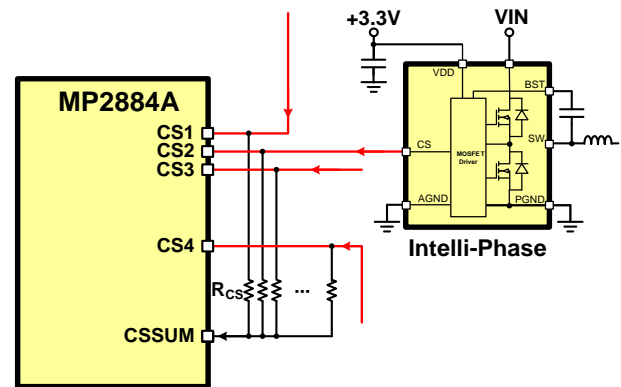

Figure 4: Phase Current Sense

Different types of Intelli-Phase products have different operating voltage ranges for CS (V_{CS_MIN} and V_{CS_MAX}). Refer to each Intelli-Phase's datasheet to determine the minimum and maximum operating voltage ranges. Calculate a proper R_{CS} value with Equation (10):

$$V_{CS_MIN} < I_{LOAD} \times K_{CS} \times R_{CS} + 1.23\text{V} < V_{CS_MAX} \quad (10)$$

By working with the Intelli-Phase, the MP2884A does not need temperature compensation and impedance matching compared with traditional DCR sensing to achieve an accurate current sense.

Total Current Sensing

The total current is summed from CSSUM, and a 1/16 proportional current emerges to IMON. Connect a resistor from IMON to AGND to generate a voltage proportional to the output current. The IMON voltage is sampled, calculated, and stored in the registers. This

result is used for total OCP, auto-phase shedding, and output power calculation and can be monitored via the PMBus.

If the auto-phase-shedding function is enabled, the total current report is used to determine the real-time phase number.

The MP2884A provides a user-programmable scaling factor and a user-programmable current offset. The programmable parameters allow users to match the IMON scaling to the design’s voltage regulator tolerance band (VRTOB) calculation. This provides the most accurate current reporting across the entire load range and maximizes the performance of the processor turbo. The scaling factor can also be reduced or offset to under-report the total current to the system for higher performance. Figure 5 shows the MP2884A IMON sense and report block diagram.

In Figure 5, the MFR_IMON_DIGI_GAIN register (2Fh) is used to fine-tune the ADC sense value with 0.1% resolution. The IOUT_CAL_GAIN register (38h) converts the sensed and trimmed IMON voltage to an ampere format with 0.25A/LSB. The detailed calculation of the register value is provided in the MP2884A application note and register map.

The voltage at IMON can be calculated with Equation (11):

$$V_{IMON} = \left(\frac{K_{CS} \times I_{OUT}}{16} \right) \times R_{IMON} \quad (11)$$

Where I_{OUT} is the load current, K_{CS} is the current sense gain of the Intelli-Phase, and R_{IMON} is the value of the resistor connected from IMON to ground.

Power Mode

To improve efficiency over the entire load range, the MP2884A supports automatic phase shedding and adjustable high/low phase count with PSI (see Table 2).

Table 2: Phase Mode Definition

PSI Pin	Mode
High	High-phase count
Hi-Z	Auto-power mode
Low	Low-phase count

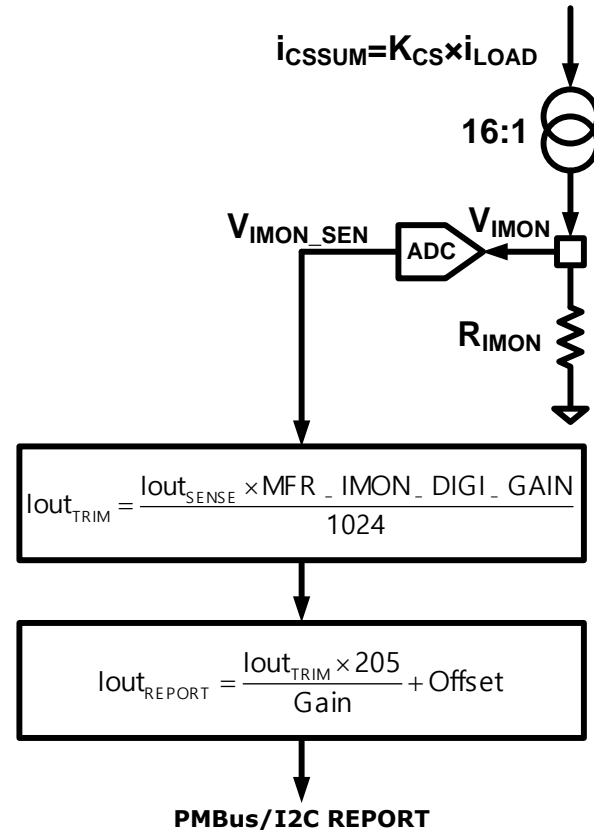

Figure 5: Current Sense and Report

In high-phase count mode, the VR is forced to operate with a full-phase count configured in register MFR_VR_CONFIG (E1h).

In low-phase count mode, the VR is forced to operate with a low-phase count configured in register MFR_LOW_PHASE_CNT (AAh).

In auto-power mode, the VR can be optimized to adjust the phase count according to the real-time sensed load current.

As shown in Figure 6, using 4-phase as an example, the VR works at 4-phase continuous conduction mode (CCM) at heavy loads, and 1-phase CCM at light loads to optimize efficiency. The VR enters 1-phase discontinuous conduction mode (DCM) at extremely light loads reduce the switching loss further.

The APM function is implanted by comparing the sensed load current with each power state current threshold. The MFR_APS_LEVEL (E3h~E7h) registers set the power state dropping thresholds. The hysteresis is set with register MFR_APS_HYS (E8h) to prevent the

converter from changing the power state back-and-forth at a steady load current. Figure 7 shows the APM current thresholds setting from 1-phase CCM to 1-phase DCM.

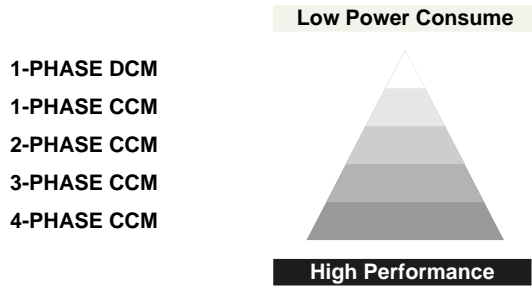

Figure 6: APM Function Diagram at 4-Phase Mode

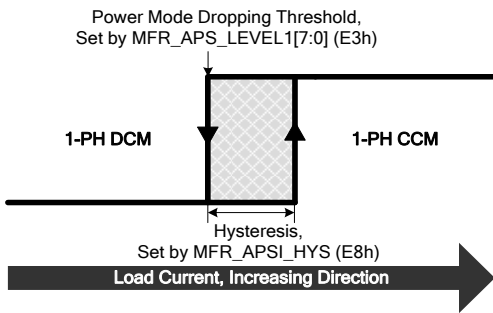

Figure 7: APM Threshold Setting between 1-Phase DCM and 1-Phase CCM

Table 3 lists the phase shedding and adding entry conditions based on the current report for 4-phase applications.

Table 3: Phase Shedding/Adding Based on Current Report for 4-Phase Applications

Condition	Phase Number
$MFR_3PH_LOW + MFR_APS_HYS < I_{LOAD}$	4-Ph CCM
$MFR_2PH_LOW + MFR_APS_HYS < I_{LOAD} \leq MFR_3PH_LOW$	3-Ph CCM
$MFR_1PH_LOW + MFR_APS_HYS < I_{LOAD} \leq MFR_2PH_LOW$	2-Ph CCM
$MFR_DCM_LOW + MFR_APS_HYS < I_{LOAD} \leq MFR_1PH_LOW$	1-Ph CCM
$I_{LOAD} \leq MFR_DCM_LOW$	1-Ph DCM

In addition to the sensed output current comparison, the MP2884A provides three conditions (listed below) to exit APM immediately and run in full-phase CCM to accelerate the load transient response and reduce the output voltage undershoot.

1. DVID makes the controller run in full-phase CCM. After the output voltage is settled to the target value, the VR resumes APM.
2. Load step-up causing a VFB window trip triggers full-phase CCM to reduce the output voltage undershoot.
3. Load step-up causing the frequency to change exceeds a programmable threshold and triggers full-phase CCM.

Current Balance and Thermal Balance

The MP2884A provides a current balance loop to achieve fair current sharing at multi-phase mode, since different circuit impedances lead to difference phase currents.

The phase current is sensed and calculated with the current reference in the current loop. Each phase’s PWM on time is adjusted individually to balance the currents accordingly.

The MP2884A applies Σ - Δ modulation and delay line-loop technology in the current-balance modulation to increase the resolution of the function and reduce PWM jitter greatly. The time resolution of the digital system is 5ns. By applying Σ - Δ modulation technology, the digital PWM resolution can be increased to 0.08ns.

Each current balance loop can also include a programmable phase current offset to achieve thermal balance among the phases. For example, a phase can have a greater cooling capability due to proximity to the airflow, which allows it to take more phase current by increasing the phase current reference with the offset to keep the phase thermal more balanced. The bandwidth of the current proportional-integral (PI) loop is relatively lower than the output voltage feedback loop, so it barely impacts the output voltage.

Input Voltage Sensing

The input power supply voltage is sampled at VINSEN with a resistor divider (see Figure 8). The sensed input voltage is used for PWM on-time calculation, VIN_UVLO, VIN_OVP fault protection, VIN_UV warning, and input voltage monitoring.

In designs, the divided voltage on VINSEN should not exceed the ADC sampling range (1.6V) at the maximum input voltage. A 1 - 10nF ceramic capacitor from VINSEN to AGND is recommended as an input sense filtering capacitor (C_{IN}) (see Figure 8).

Program the input voltage sensing divider ratio with register MFR_VIN_SCALE_LOOP (C0h). The calculation of the ratio (K_{IN}) is shown in Equation (12):

$$K_{IN} = \frac{R_{IN2}}{R_{IN1} + R_{IN2}} \quad (12)$$

$$= \frac{VIN_SCALE_LOOP}{2^{10}}$$

Where VIN_SCALE_LOOP is the decimal value in the register MFR_VIN_SCALE_LOOP (C0h).

In designs, match the resistor setting (K_{IN}) and register setting value for accurate input voltage sensing.

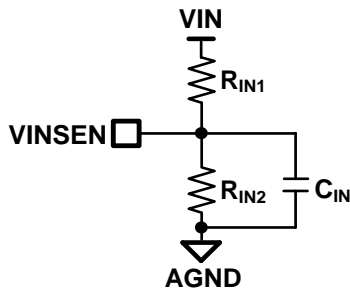

Figure 8: Input Voltage Sense Connection

Temperature Sense of Intelli-Phase

The MP2884A senses the Intelli-Phase’s temperature by connecting the Intelli-Phase’s VTEMP pin to the MP2884A’s VTEMP pin (see Figure 9). The sensed temperature is used for over-temperature fault protection, over-temperature warning (assert TALER#), and power stage temperature monitoring.

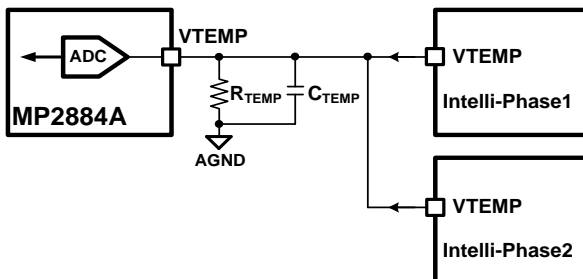

Figure 9: Temperature Sense with Intelli-Phase

C_{TEMP} is a VTEMP pin filtering capacitor (recommend to be a 10nF ceramic capacitor). R_{TEMP} is a discharging resistor when the junction temperature is falling (ranging from 10 - 49.9k Ω).

The VTEMP pin of the Intelli-Phase reports a voltage proportional to the junction temperature. Set the calculation gain and offset in register MFR_TEMP_GAIN_OFFSET (C1h).

An example of the Intelli-Phase VTEMP voltage is shown in Equation (13):

$$T_{JUNCTION} (^{\circ}C) = 100 \times V_{TEMP} (V) + 10 \quad (13)$$

for $T_{JUNCTION} > 10^{\circ}C$

If VTEMP is 700mV, then the junction temperature of the Intelli-Phase is 80 $^{\circ}C$. Since VTEMP cannot go below 0V, it reads 0V when the junction temperature is lower than 10 $^{\circ}C$. Refer to the datasheet of the Intelli-Phase for more information.

Temperature Sense of the Thermistor

The MP2884A senses the external thermal component’s temperature by connecting a thermistor to TSNS (see Figure 10). The sensed temperature is used for over-temperature fault protection and over-temperature warning (assert TALER#).

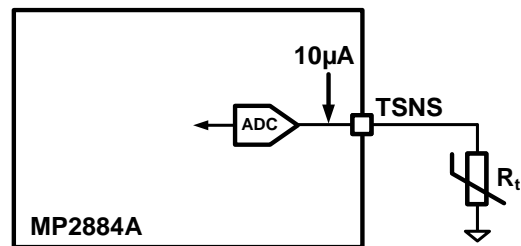

Figure 10: Temperature Sense with Thermistor

TSNS sources a 10 μA current source to the thermistor, and the MP2884A senses the voltage of TSNS. The 10 μA current source can be disabled via register TSNS_CURRENT_DIS (34h bit[10]), and a voltage signal can be connected to TSNS as a new defined protection function.

Note that if the 10 μA current source is enabled, TSNS cannot be floated.

EEPROM Operation

The MP2884A provides an EEPROM to store custom configurations. A 4-digit part number suffix is assigned for each application. The default configuration for each 4-digit part can be pre-programmed at the MPS factory. The data can be programmed again using the STORE_USER_ALL (15h) command via the PMBus and requires 200ms of time for the data to be stored to the EEPROM. The EEPROM is read automatically during the power-on sequence or by the RESTORE_USER_ALL (16h) command via the PMBus and requires at least 300 μ s of time for data to be restored from the EEPROM.

The operation to the EEPROM can be accomplished easily with the MPS GUI software.

The MP2884A uses register DBh to enable EEPROM write protection.

The EEPROM can be erased or written for more than 100,000 cycles. When the EEPROM is write-protected, the write into EEPROM action is ineffective.

EEPROM Fault

If the data from the EEPROM is checked as invalid by the cyclic redundancy code (CRC) during the system initialization process, the system enters an EEPROM fault state without outputting power and waits for the error clear command. The configuration from the EEPROM is ignored.

There are three ways to clear the EEPROM fault and start up again with the restored value from the EEPROM:

1. Clear the EEPROM fault via the PMBus command (FFh).
2. Clear the fault status via the PMBus command (03h).
3. Store the configuration into the EEPROM and restart.

Low-Power Mode

The MP2884A can be programmed to operate in regular-power mode or low-power mode.

In regular-power mode, the PMBus communication is available when EN is low. With low-power mode enabled, when EN is low,

the PMBus communication is disabled, and the quiescent current (I_Q) can be reduced to 150 μ A.

Low-power mode is factory-programmable.

Power-On

The MP2884A is supplied by a +3.3V voltage at VDD33. VDD33 provides the bias supply for the analog circuit and internal 1.8V LDO. The 1.8V LDO produces the +1.8V supply for the digital circuit. The system is reset by the internal power-on reset signal (POR) after the VDD33 supply is ready. If the MP2884A is in regular-power mode, EN must be high. After the system exits POR, the data in the EEPROM is loaded into the operating registers to configure the VR operation.

Figure 11a shows the power-on sequence of the MP2884A in regular-power mode.

t0~t1: at t0, VDD33 is supplied by a +3.3V voltage and reaches the VDD33 UVLO_ON threshold at t1. VDD18 reaches +1.8V when VDD33 is higher than 1.8V.

t1~t2: at t1, the data in the EEPROM starts loading into the operating registers. The entire EEPROM copy process takes about 300 μ s, typically. During this stage, the PMBus address is detected if the voltage on ADDR is selected to set the PMBus address.

t2~t3: at t2, after the EEPROM copy is finished, the MP2884A waits for EN to pull high. The PMBus is available at this stage.

t3~t4: when EN is high, if the PMBus command OPERATION (01h) is pre-set to an off state. The MP2884A halts at this stage and waits for the OPERATION on command. If OPERATION (01h) is pre-programmed to an on state, the turn-on delay time (T_{ON} delay) begins counting. The T_{ON} delay is PMBus-programmable from 0 to 3276.75ms with the command TON_DELAY (60h).

t4~t5: when the T_{ON} delay time expires, the VID-DAC starts ramping up V_{REF} and a programmed slew rate to the boot-up voltage. During soft start, OCP_Total, OVP, and UVP are masked until V_{REF} reaches the target value.

In PWM-VID mode, before t5, PWM-VID should remain at a Hi-Z state.

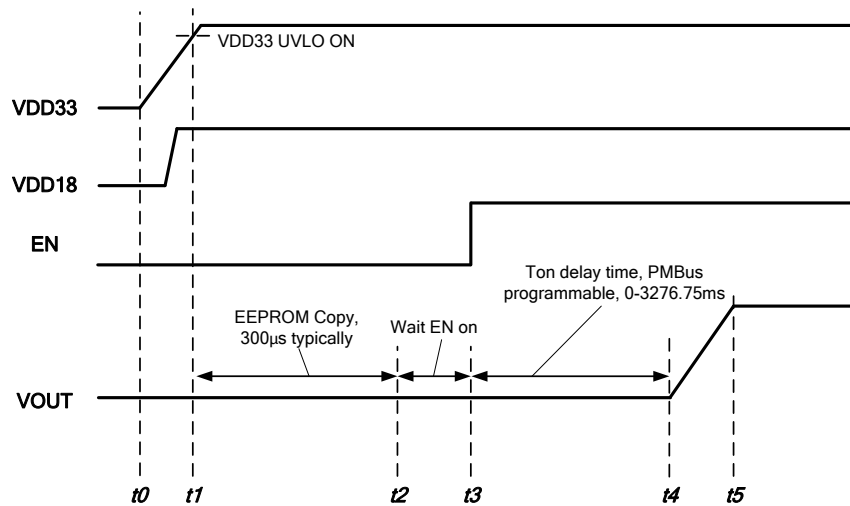

Figure 11a: MP2884A Power-On Sequence at Regular-Power Mode

Figure 11b shows the power-on sequence of the MP2884A in low-power mode.

t0~t1: at t0, VDD33 is supplied by a +3.3V voltage and reaches the VDD33 UVLO_ON threshold at t1. VDD18 reaches +1.8V when VDD33 is greater than 1.8V.

t1~t2: after t1, VDD33 rises above the UVLO_ON threshold, and the MP2884A waits for EN to pull high. The PMBus is unavailable at this stage.

t2~t3: at t2, EN pulls high, the data in the EEPROM starts loading into the operating registers. The entire EEPROM copy process takes about 300µs, typically. During this stage, the PMBus address is detected if the voltage on ADDR is selected to set the PMBus address.

t3~t4: after the EEPROM copy is finished, if the PMBus command OPERATION (01h) is pre-set to an off state. The MP2884A halts at this stage and waits for an OPERATION on command. If OPERATION (01h) is pre-programmed to an on state, the turn-on delay time (T_{ON} delay) begins counting. The T_{ON} delay is PMBus-programmable from 0 to 3276.75ms with the command TON_DELAY (60h).

t4~t5: when the T_{ON} delay time expires, the VID-DAC starts ramping up V_{REF} with a programmed slew rate to the boot-up voltage. During soft start, OCP_Total, OVP, and UVP are masked until V_{REF} reaches the target value.

In PWM-VID mode, before t5, PWM-VID should remain at Hi-Z.

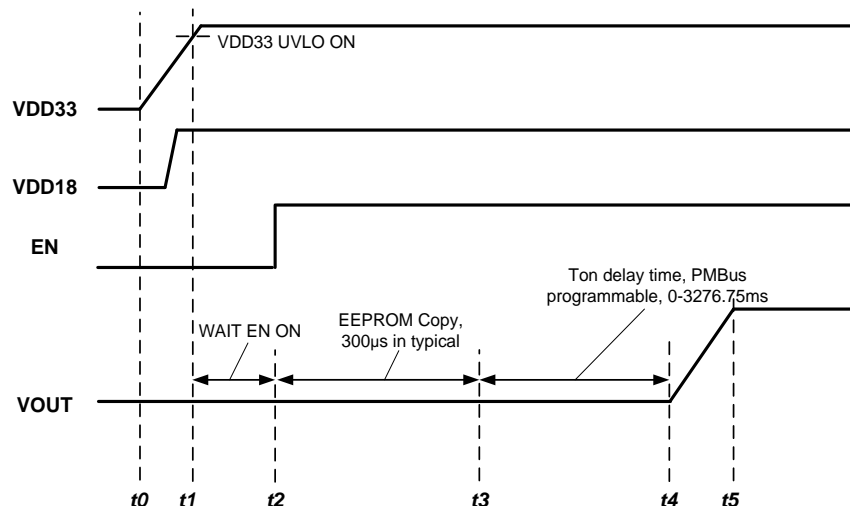
Figure 11b: MP2884A Power-On Sequence at Low-Power Mode

Power-Off

The MP2884A can be powered off by the OPERATION command, EN, or VDD33.

1. OPERATION command off: The MP2884A provides Hi-Z off and soft off with commands. During soft off, V_{OUT} drops down with a pre-programmed slew rate in register MFR_BOOT_SR (B9h) until V_{REF} reaches the level of register MFR_VID_SD (BCh) and then enters Hi-Z off. This prevents V_{OUT} from becoming negative during the shutdown process. A turn-off delay can be set via register TOFF_DELAY (64h).
2. EN off: The MP2884A provides Hi-Z off and soft-off when EN is pulled low in regular-power mode. During soft off, V_{OUT} drops down with a pre-programmed slew rate in register MFR_BOOT_SR (B9h) until V_{REF}

reaches the level of register MFR_VID_SD (BCh) and then enters Hi-Z off. This prevents V_{OUT} from becoming negative during the shutdown process. A turn-off delay can be set via TOFF_DELAY (64h).

In low-power mode when EN is pulled low, the MP2884A can enter Hi-Z off without any turn-off delay immediately, and enters standby mode with the smallest amount of power consumption.

3. VDD33 power-off: When the voltage on VDD33 falls below the UVLO threshold, the MP2884A powers off immediately. All PWMs enter Hi-Z.

Figure 12a shows the EN soft-off power sequence in regular-power mode.

Figure 12b shows the EN Hi-Z off power sequence in low-power mode.

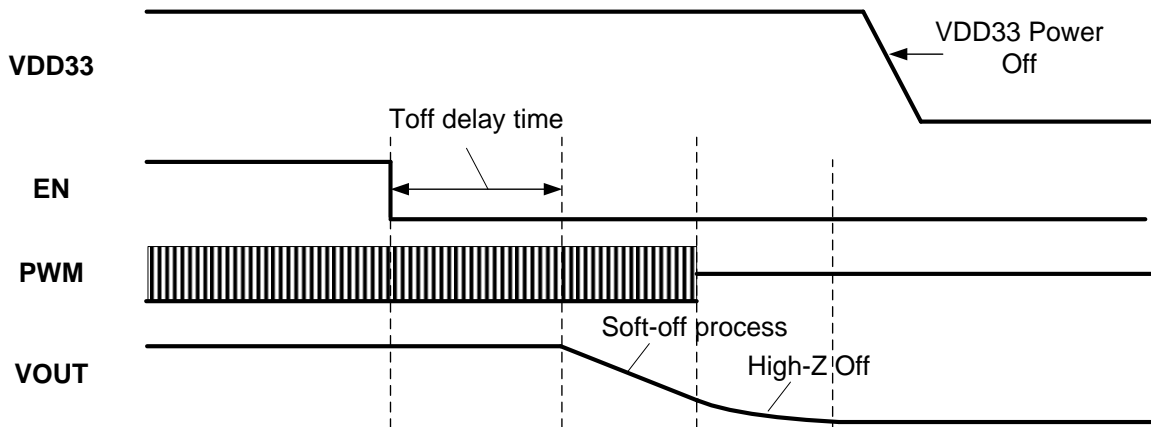

Figure 12a: MP2884A Power-Off Sequence in Regular-Power Mode

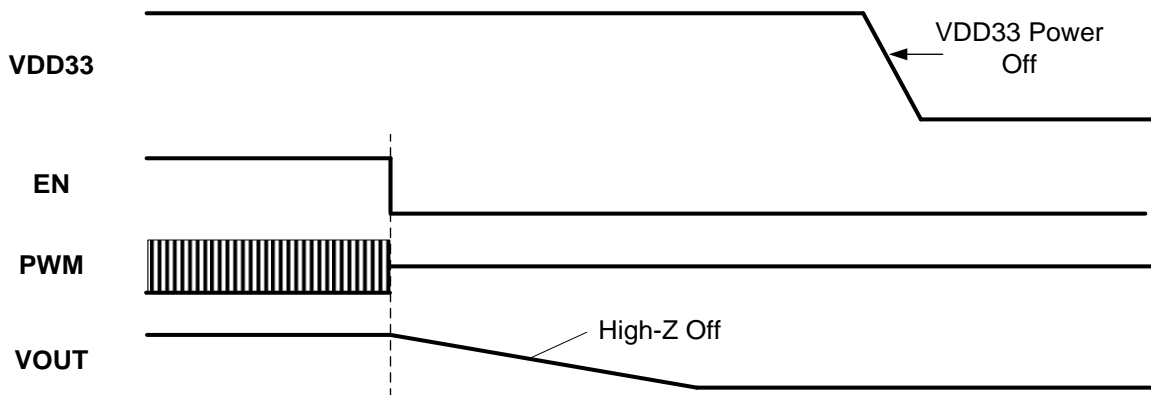

Figure 12b: MP2884A Power-Off Sequence in Low-Power Mode

Power Good Indication (PGOOD)

The MP2884A power good (PGOOD) on/off thresholds are programmable via POWER_GOOD_ON (5Eh) and POWER_GOOD_OFF (5Fh).

During the soft-start process, when V_{REF} rises above the POWER_GOOD_ON threshold, the MP2884A starts a delay counter before asserting PGOOD. The delay counter time is programmable via register MFR_DELAY_SET (5Dh).

During the soft-shutdown process, when V_{REF} falls below the POWER_GOOD_OFF threshold, the MP2884A de-asserts PGOOD immediately. The POWER_GOOD_OFF threshold must be set below the VID value, which is regulated during the normal operation process.

For Hi-Z shutdown caused by protections or EN turning off, PGOOD is de-asserted immediately. Figure 13 shows the power good indication in regular-power mode.

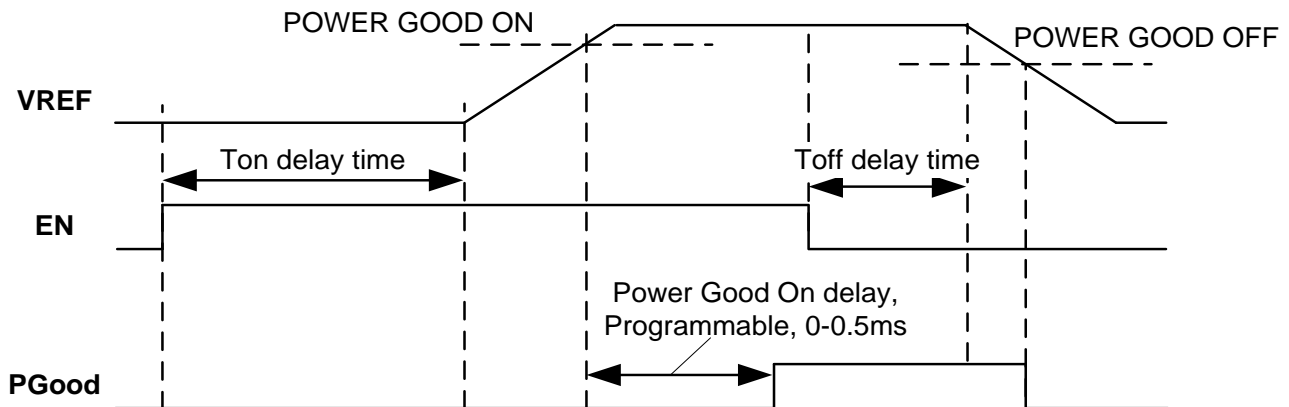

Figure 13: MP2884A Power Good On/Off Sequence in Regular-Power Mode

Fault and Protections

The MP2884A supports the following fault monitoring and protections.

V_{IN} UVLO and OVP

The VR can shut down immediately by forcing the PWM signals into tri-state if the sensed input voltage is below the V_{IN_OFF} threshold. The VR restarts when the sensed input voltage is above the V_{IN_ON} threshold. The V_{IN} UVLO threshold is programmable with register V_{IN_ON} (35h) and V_{IN_OFF} (36h) with 0.125V/LSB.

V_{FB} Window

The MP2884A has a feedback voltage (V_{FB}) window ($V_{REF} \pm 25mV$), which provides an advanced non-linear loop control to fasten the transient performance.

When V_{FB} is higher than $V_{REF} + 25mV$ (V_{FB} positive window limit), all PWMs pull low and blank the PWM set signal until V_{FB} falls below the positive limit. The V_{FB} positive window is used to reduce the output voltage overshoot at the load release, typically, especially in multi-phase operation.

When V_{FB} is lower than $V_{REF} - 25mV$ (V_{FB} negative window limit), VR exits auto-power mode immediately and enters full-phase running to improve the transient response.

VR latches if the input voltage is above the V_{IN} OVP threshold, which is set with register $V_{IN_OV_FAULT_LIMIT}$ (55h).

Over-Current Protection (OCP)

OCP applies a dual OCP mechanism with two types of thresholds.

The first OCP type, OCP_Total , is a time- and current-based threshold. The PMBus sets the OCP_Total threshold using MFR_OCP_TOTAL (ECh). OCP_Total should trigger when the sensed average output current exceeds the

threshold for a period of time referred to as the OCP blanking time. OCP_Total can be programmed to no action, hiccup, retry six times, and latch-off mode via the PMBus.

The controller does not take action in no action mode and keeps the PWMs switching. The fault indication bit in register STATUS_IOUT (7Bh) and STATUS_WORD (79h) is not set in no action mode.

In hiccup mode, the controller forces the PWM signals into tri-state to disable the output. The controller attempts to restart after 12.5ms of protection delay time.

In retry six times mode, the VR hiccups six times at most. If the fault is removed within the six restarts, the VR resumes normal operation. If the fault remains after the six restarts, the VR shuts down until a new power cycle, an EN toggle, or a PMBus COMMAND ON occurs.

In latch mode, the VR shuts down until a new power cycle, an EN toggle, or a PMBus COMMAND on occurs.

These four protection types are also available for V_{OUT} UVP and V_{OUT} OVP2.

The second OCP type, OCP_Phase, is a current-based limitation threshold. The MP2884A monitors the phase current cycle-by-cycle. When the phase current exceeds the OCP_Phase threshold at the PWM off time, the PWM remains low to discharge the inductor current. If the load current continues rising, the output voltage drops because the inductor current is limited. OCP_Phase is implemented with V_{OUT} UVP, generally. The OCP_Phase threshold is PMBus-programmable with register MFR_OCP_PHASE (EDh).

Under-Voltage Protection (UVP)

The MP2884A monitors the VDIFF voltage to provide UVP and uses a dual UVP approach.

The first UVP type, UVP1, is a digital UVP. UVP1 is triggered when the internal ADC senses that the VDIFF voltage is lower than the threshold for a pre-set blanking time. The UVP1 threshold can be set from 0 - 480mV with 32mV of resolution. Refer to the register MFR_SYS_CONFIG (44h) section on page 54.

The second UVP type, UVP2, is triggered when the VDIFF voltage is lower than the threshold for a pre-set blanking time. The register OVUV_LEVEL (2Ch) can program the UVP2 threshold to V_{REF} - 430mV, V_{REF} - 310mV or V_{REF} - 190mV. Refer to the MFR_OVUV_SEL (2Ch) section on page 44. When programming the gain of the differential voltage sense amplifier as half, the UVP2 threshold is doubled. For example, set the register to a -430mV level to achieve the V_{REF} - 860mV threshold.

The UVP scheme is the same as the OCP_Total protection scheme. When the VDIFF voltage is lower than the UVP threshold for a given amount of time (UVP blanking time), the controller forces the PWM signals into tri-state to disable the output. The register MFR_OVP_UVP_SET (EEh) sets the UVP mode and blanking time. Like the OCP_Total protection scheme, the UVP scheme also provides no action, hiccup, retry six times, and latch-off options.

Over-Voltage Protection (OVP)

The MP2884A monitors the VDIFF voltage to provide OVP and uses a dual OVP approach (described below). When OVP is triggered, the MP2884A pulls all activated PWMs low to turn on the low-side MOSFET to discharge the output capacitors until V_{OUT} reaches +300mV. Then all PWMs are set to Hi-Z.

The first OVP type, OVP1, is triggered when the VDIFF voltage is higher than the OVP1 threshold without any delay time. The OVP1 fault is in latch-off mode.

The OVP1 threshold is V_{OUT_MAX} (24h) +400mV, regardless of the gain of the differential voltage sense amplifier.

The second OVP type, OVP2, is triggered when the VDIFF voltage above the OVP2 threshold for a pre-set blanking time. Just like in UVP, the MP2884A provides no action, hiccup, retry six times, and latch-off modes for the OVP2 fault.

The register MFR_OVUV_LEVEL (2Ch) can program the OVP2 level to V_{REF} + 430mV, V_{REF} + 310mV, and V_{REF} + 190mV. Refer to the MFR_OVUV_SEL (2Ch) section on page 44. When programming the gain of the differential voltage sense amplifier as half, the OVP2 threshold is doubled. For example, set the

register to a +190mV level to achieve the $V_{REF} + 380\text{mV}$ threshold.

Over-Temperature Protection (OTP)

The MP2884A uses a dual OTP approach.

The first OTP type is VTEMP protection from the Intelli-Phase (see Figure 9). If the VTEMP report value is higher than the threshold in the register OT_WARN_LIMIT (51h), TALERT# is asserted.

If the VTEMP report value is higher than the threshold in the register VTEMP_OTP_THRE (EAh), the VR Hi-Z shuts down.

The VTEMP fault can be programmed to either latch-off mode or hiccup mode via register VTEMP_OTP_MODE (EAh).

The second OTP type is TSNS protection from the thermistor (see Figure 10). If the TSNS report value is higher than the threshold in register TSNS_T_ALT_THRE (34h), TALERT# is asserted. If the TSNS report value is higher than the threshold in register TSNS_OTP_THRE (E9h), the VR shuts down.

The TSNS fault can be programmed to no action, latch-off, or hiccup mode via register TSNS_OTP_MODE (E9h).

Intelli-Phase Fault Detection

When VTEMP is pulled up to 3.3V or any CS pin is pulled down to 0V, the MP2884A latches off immediately. These protections are called VTEMP fault protection and CS fault protection.

When VTEMP or CS fault protection occurs, the MP2884A can detect the fault type of the Intelli-Phase. There are four typical fault types:

- Over-current fault
- Over-temperature fault
- Low-side MOSFET fault
- High-side MOSFET fault

Fault type detection only works when the Intelli-Phase supports fault type indication via PWMx. Refer to the datasheet of the Intelli-Phase for specific details. Figure 14 shows the flow chart of Intelli-Phase fault detection.

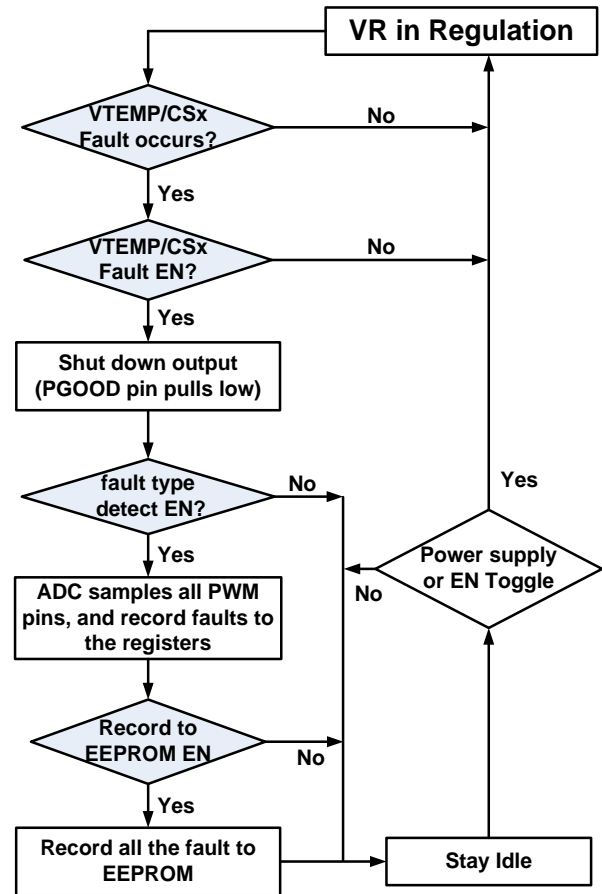

Figure 14: Flow Chart of Intelli-Phase Fault Detection

The related registers are described below.

1. The enable bit of the VTEMP and CS fault function is bit[9:8] of MFR_PROTECT_DIS (3Ah).
2. The enable bit of the ADC sampling the fault type from the Intelli-Phase PWM is bit[10] of MFR_PROTECT_DIS (3Ah).
3. The enable bit to record a fault to the EEPROM is bit[1] of MFR_EEPROM_CTRL (06h).

Protection Type Storage in the EEPROM

Once any protection occurs, the fault type is recorded to Page 0's registers F8h ~ FBh. If the EEPROM fault record is enabled, the last fault event is recorded in Page 29's registers FBh ~ FEh. EN must remain high for at least 20ms after the fault occurs to save the fault type into the EEPROM.

To clear the fault record in the EEPROM registers, 0x0000 must be written to these registers (Page 29 FBh ~ FEh). This is a direct access to the EEPROM registers. The time required for each write command is 5ms.

Phase Number Configuration

The MP2884A can be configured to different phase numbers via the PMBus register or by CSx (see Table 4).

Table 4: Phase Number Configuration and Activated PWM Pins

PHASE_CNT (E1h)	Activated PWM Pins
1	PWM1
2	PWM1~2
3	PWM1~3
4	PWM1~4

If PHASE_CNT is set to 0, the MP2884A operates in 1-phase DCM.

Any unused PWM pin enters tri-state, and the activated phases interleave automatically. Float the unused PWM pins. For the Intelli-Phase, if the PWM input is in Hi-Z, the SW node is in Hi-Z as well.

If the CS pins are enabled to program the phase number, the register setting in E1h is ignored. Pull down the unused CS pins to ground. After EN is pulled high, the MP2884A checks the voltage on the CS pins sequentially from CS1 to CS4 until it finds the first low voltage. Figure 15 shows an example of the connection for 3-phase applications. The first low voltage is on CS4.

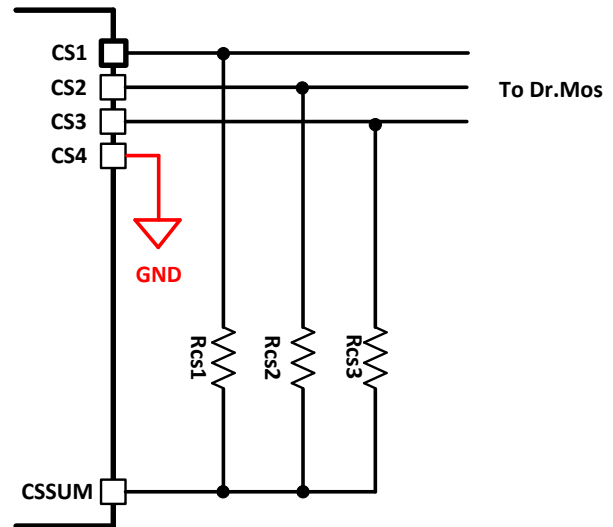

Figure 15: CS Pins Program to 3-Phase

PMBUS/I²C COMMUNICATION

General Description

The Power Management Bus (PMBus) is an open-standard, power-management protocol that defines a means of communicating with power conversion and other devices. The PMBus is a two-wire, bidirectional serial interface consisting of a data line (SDA) and a clock line (SCL). The lines are pulled to a bus voltage externally when they are idle. When connecting the PMBus to the line, a master device generates the SCL signal and device address and arranges the communication sequence. This is based on the principles of I²C operation.

The MP2884A supports 100kHz, 400kHz, and 1MHz bus timing requirements. Timing and electrical characteristics of the PMBus can be found in the Electrical Characteristics section on page 7 to page 9 or in the PMBus Power Management Protocol Specification part 1, revision 1.3 available at <http://PMBus.org>.

PMBus/I²C Address

To support multiple VR devices being used with the same PMBus/I²C interface, the MP2884A provides PMBus address programming via ADDR or a register.

The device address is a 7-bit code and ranges from 0x00 to 0x7F. The 3MSB bits are set by the register. The 4LSB bits can be set either by the register or by the ADDR voltage.

The address of 00h is reserved as the all-call address. Do not use 00h as the MP2884A address.

The register MFR_PMBUS_ADDR (BEh) is used to program or store the device address. Bit[7] sets the mode of the 4LSB address. When bit[7] = 0, the 4LSB bits are determined by the voltage of ADDR, and its value is stored in register BEh bit[3:0] automatically.

The ADDR voltage can be set by a resistor divider (see Figure 16). Using 3MSB = 3'b010 as an example, Table 6 shows the resistor values for different 4LSB addresses.

Table 6: Pin Configuration for PMBus/I²C Address

PMBus Address	Setting Point (V)	R _{ADDR1} (kΩ) 1%	R _{ADDR2} (kΩ) 1%
20h	0	-	0
21h	0.031	3.32	0.059
22h	0.057	3.32	0.11
23h	0.084	3.32	0.162
24h	0.116	3.32	0.226
25h	0.156	3.32	0.316
26h	0.205	3.32	0.43
27h	0.266	3.32	0.576
28h	0.340	3.32	0.768
29h	0.430	3.32	1.05
2Ah	0.540	3.32	1.43
2Bh	0.675	3.32	2
2Ch	0.844	3.32	2.94
2Dh	1.048	3.32	4.64
2Eh	1.301	3.32	8.66
2Fh	1.500	3.32	16.5

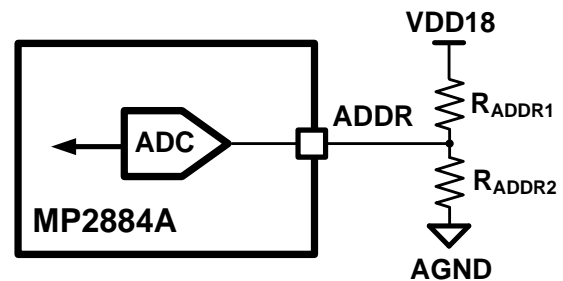

Figure 16: Recommend Circuit Design of ADDR

Data and Numerical Format

The MP2884A uses the direct format internally to represent real-world values such as voltage, current, power, temperature, time, etc.

All numbers with no suffix in this document are in a decimal format unless explicitly designated otherwise.

Numbers in a binary format are indicated by a prefix n'b, where n is the binary count. For example, 3'b000 is a 3-bit binary data, and the data is 000. The suffix h indicates a hexadecimal format, which is used for the register address number in this document.

The symbol 0x indicates a hexadecimal format, which is used for the value in the register. For example, 0x88 is a 1-byte number whose decimal value is 136.

PMBus Communication Failure

A data transmission fault occurs when the data is not transferred properly between the devices. There are several types of data transmission faults listed below.

- Sending too few data
- Reading too few data
- Master sending too many bytes
- The MP2884A reading too many bytes
- Improperly set read bit in the address byte
- Unsupported command code

The CLEAR_FAULTS (03h) command can be used to clear the fault record.

PMBus/I²C Transmission Structure

The MP2884A supports five kinds of transmission structures with or without PEC.

1. Send command only
2. Write byte
3. Write word
4. Read byte
5. Read word

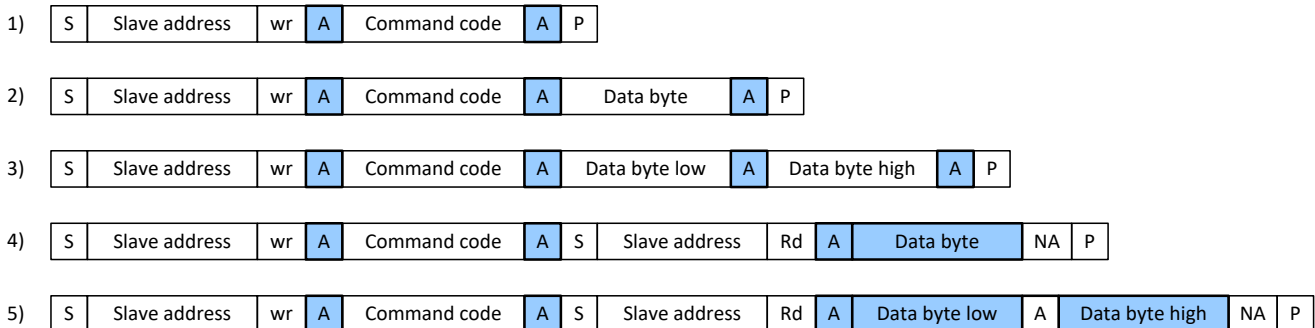

S	start	<input type="checkbox"/>	Master to slave
P	stop	<input type="checkbox"/>	Slave to master
A	ACK	Wr	write (bit value=0)
NA	NACK	Rd	read (bit value=1)

Figure 17a: Supported PMBus/I²C Transmission Structure without PEC

The MP2884A can support the packet error checking (PEC) mechanism, which can improve reliability and communication robustness. The PEC is a CRC-8 error-checking byte calculated on all the message bytes (including addresses and read/write bits). The MP2884A only processes the message if the PEC is correct.

The PEC is calculated in CRC-8 represented by the polynomial in Equation (14):

$$C(x) = x^8 + x^2 + x^1 + 1 \quad (14)$$

Figure 17a shows the supported PMBus/I²C transmission structure without PEC. Figure 17b shows the supported PMBus/I²C transmission structure with PEC.

To read or write registers of the MP2884A, the PMBus/I²C command must be compliant with the byte number of the registers in the table of the register map.

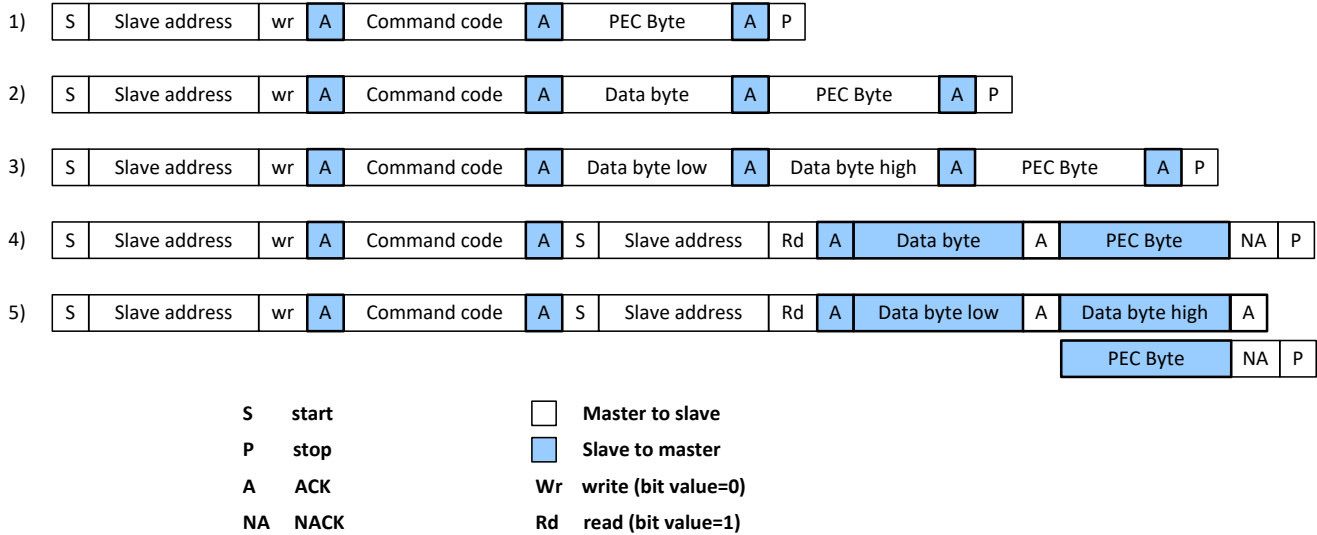
Figure 17b: Supported PMBus/I²C Transmission Structure with PEC
PMBus Reporting and Status Monitoring

The MP2884A supports real-time monitoring of the VR operation parameters and status using the PMBus interface (see Table 7).

For high-power applications with an output current greater than 1024A, the MP2884A uses register bits to scale the current rate of the platform via register MFR_SYS_CONFIG (44h).

When the total current report range is doubled, the setting of the registers in Table 8 should be updated accordingly.

When the phase current report range is doubled, the setting of the registers in Table 9 should be updated accordingly.

Table 7: PMBus Monitored Parameters

Parameter	PMBus	Register
Output voltage	1mV/LSB	8Bh
Output current	Refer to Table 8	8Ch
Output power		96h
Input power		97h
Temperature	0.1°C/LSB	8Dh
Input voltage	0.03125V/LSB	88h
Phase current	Refer to 73h~77h	
V _{OUT} OV fault	✓	7Ah
V _{OUT} UV fault	✓	7Ah
OC fault	✓	7Bh
OT fault	✓	7Dh
V _{IN} UVLO fault	✓	7Ch
V _{IN} OVP fault	✓	7Ch
PMBus fault	✓	7Eh
EEPROM fault	✓	7Eh
V _{OUT} UV warn	✓	7Ah
VID max/min extend warn	✓	7Ah
OC warn	✓	7Bh
OP warn	✓	7Bh
OT warn	✓	7Dh
V _{IN} UV warn	✓	7Ch
PEC error	✓	7Eh
CRC error	✓	7Eh

Table 8: Registers Related to Total Current Report Rate

Register	MFR_SYS_CONFIG (44h) Bit[3]	
	1'b0	1'b1
Output current (8Ch)	0.25A/LSB	0.5A/LSB
Output power (96h)	0.5W/LSB	1W/LSB
Input power (97h)		
POUT_OP_WARN_LIMIT (6Ah)	1W/LSB	2W/LSB
IOUT_OC_WARN_LIMIT (4Ah)	1A/LSB	2A/LSB
MFR_APS_LEVLE (E3h~E7h)		
MFR_APS_HYS (E8h)		
OCP_THRESHOLD (ECh)		
IOUT_CAL_GAIN (38h)	Refer to register map	
IOUT_CAL_OFFSET (39h)		

Table 9: Registers Related to Phase Current Report Rate

Register	MFR_SYS_CONFIG (44h) Bit[4]	
	1'b0	1'b1
Phase current (73h~77h)	x1	x2
MFR_OCP_PHASE (EDh)	1A/LSB	2A/LSB
MFR_CUR_GAIN (C2h)	Refer to register map	
MFR_CS_OFFSET (4Ch~4Eh)		

PMBus Write Protection

The MP2884A supports PMBus write protection (WP) by entering a 16-bit password in register MFR_USER_PWD (04h). Store the password to the EEPROM, and after the power-on reset, no register can be written via the PMBus until the correct password is entered.

Note that if a wrong password is entered, the MP2884A disables the PMBus write function until the VDD33 supply toggles.

The correct password can be entered only once. If the password is sent more than once, correct or not, the MP2884A disables the PMBus write function until the VDD33 supply toggles.

Set the register MFR_USER_PWD (04h) to 0x0000 if the password function is not needed.

PMBUS COMMANDS @ PAGE 0

Command Code	Command Name	Type	Bytes
00h	PAGE	r/w	1
01h	OPERATION	r/w	1
03h	CLEAR_FAULTS	Send	0
04h	MFR_USER_PWD	w	2
05h	BUF_REG_UPD	Send	0
06h	MFR_EEPROM_CTRL	r/w	1
13h	WRITE_PROTECT	r/w	1
15h	STORE_USER_ALL	Send	0
16h	RESTORE_USER_ALL	Send	0
1Ch	MFR_DROOP_CMPN1	r/w	2
1Dh	MFR_DROOP_CMPN2	r/w	2
1Eh	MFR_IDROOP_CTRL	r/w	1
1Fh	VOUT_MIN	r/w	2
21h	VOUT_COMMAND	r/w	2
23h	VOUT_OFFSET	r/w	2
24h	VOUT_MAX	r/w	2
25h	VOUT_MARGIN_HIGH	r/w	2
26h	VOUT_MARGIN_LOW	r/w	2
27h	VENDOR_ID_USER	r/w	1
28h	PRODUCT_ID_USER	r/w	1
29h	PRODUCT_REV_USER	r/w	1
2Ah	MFR_DC_DIV_SET	r/w	2
2Bh	MFR_IDROOP_OFFSET	r/w	1
2Ch	MFR_OVUV_SEL	r/w	2
2Dh	MFR_RSAMP_OFFSET	r/w	1
2Eh	MFR_VFB_DIGI_GAIN	r/w	2
2Fh	MFR_IMON_DIGI_GAIN	r/w	2
30h	MFR_DC_LOOP_CTRL	r/w	2
31h	MFR_CB_LOOP_CTRL	r/w	1
32h	MFR_FS_LOOP_CTRL	r/w	2
34h	MFR_T_ALERT_CTRL	r/w	2
35h	VIN_ON	r/w	2
36h	VIN_OFF	r/w	2
38h	IOUT_CAL_GAIN	r/w	2
39h	IOUT_CAL_OFFSET	r/w	2
3Ah	MFR_PROTECT_DIS	r/w	2
3Bh	MFR_PS_FORCE	r/w	2
3Dh	MFR_SLOPE_ADV	r/w	2
3Fh	MFR_PWM_LIMIT	r/w	2
40h	MFR_OSR_SET	r/w	2
43h	MFR_T_ALERT_CTRL2	r/w	2
44h	MFR_SYS_CONFIG	r/w	2

PMBUS COMMANDS @ PAGE 0 (continued)

Command Code	Command Name	Type	Bytes
45h	MFR_VR_CONFIG3	r/w	2
46h	CONFIG_ID	r/w	2
47h	CONFIG_REV_MPS	r/w	2
4Ah	IOUT_OC_WARN_LIMIT	r/w	2
4Ch	MFR_CS_OFFSET1	r/w	2
4Dh	MFR_CS_OFFSET2	r/w	2
4Eh	MFR_CS_OFFSET3	r/w	2
51h	OT_WARN_LIMIT	r/w	2
55h	VIN_OV_FAULT_LIMIT	r/w	2
58h	VIN_UV_WARN_LIMIT	r/w	2
5Dh	MFR_DELAY_SET	r/w	2
5Eh	POWER_GOOD_ON	r/w	2
5Fh	POWER_GOOD_OFF	r/w	2
60h	TON_DELAY	r/w	2
64h	TOFF_DELAY	r/w	2
6Ah	POUT_OP_WARN_LIMIT	r/w	2
6Bh	START_CATCH_AVE	Send	0
73h	READ_CS1_2	r	2
74h	READ_CS3_4	r	2
75h	READ_CS5_6	r	2
76h	READ_CS7_8	r	2
77h	READ_CS9_10	r	2
78h	STATUS_BYTE	r	1
79h	STATUS_WORD	r	2
7Ah	STATUS_VOUT	r	1
7Bh	STATUS_IOUT	r	1
7Ch	STATUS_INPUT	r	1
7Dh	STATUS_TEMPERATURE	r	1
7Eh	STATUS_CML	r	1
88h	READ_VIN	r	2
8Bh	READ_VOUT	r	2
8Ch	READ_IOUT	r	2
8Dh	READ_TEMPERATURE	r	2
95h	READ_EFFICIENCY	r	2
96h	READ_POUT	r	2
97h	READ_PIN	r	2
A3h	MFR_APS_FS_LIMIT1	r/w	2
A4h	MFR_APS_FS_LIMIT2	r/w	2
A5h	MFR_APS_FS_LIMIT3	r/w	2
A6h	MFR_APS_FS_LIMIT4	r/w	2
A7h	MFR_APS_FS_CTRL1	r/w	2

PMBUS COMMANDS @ PAGE 0 (continued)

Command Code	Command Name	Type	Bytes
A8h	MFR_APS_FS_CTRL2	r/w	2
A9h	MFR_PHASE_SHED_CTRL	r/w	2
AAh	MFR_LOW_PHASE_CNT	r/w	2
ABh	MFR_APS_CTRL	r/w	2
ADh	MFR_REPORT_CTRL	r/w	2
A Eh	MFR_PWMVID_TARGET_CTRL	r/w	2
AFh	MFR_PWMVID_UP_COMP	r/w	2
B0h	MFR_PWMVID_MAX_DUTY	r/w	2
B1h	MFR_PWMVID_FLTR_CTRL1	r/w	2
B2h	MFR_PWMVID_FLTR_CTRL2	r/w	2
B3h	MFR_DUTY_TO_VID_GAIN	r/w	2
B4h	MFR_PARM_VOUT_MIN	r/w	2
B5h	MFR_PARM_RC_CONST	r/w	2
B6h	MFR_PARM_VBOOT_DUTY	r/w	2
B7h	MFR_PARM_SLEW_TRAN	r/w	2
B8h	MFR_PARM_BOOT_TRAN	r/w	2
B9h	MFR_BOOT_SR	r/w	2
BAh	MFR_SLEW_SR	r/w	2
BBh	MFR_VBOOT	r/w	2
BCh	MFR_VID_SD	r/w	2
BDh	MFR_FS	r/w	2
BEh	MFR_PMBUS_ADDR	r/w	1
BFh	MFR_VIN_SENSE_OFFSET	r/w	2
C0h	MFR_VIN_SCALE_LOOP	r/w	1
C1h	MFR_TEMP_GAIN_OFFSET	r/w	2
C2h	MFR_CUR_GAIN	r/w	2
C5h	MFR_BLANK_TIME	r/w	2
C6h	MFR_SLOPE_SR_DCM	r/w	2
C7h	MFR_SLOPE_CNT_DCM	r/w	2
C8h	MFR_SLOPE_SR_10P	r/w	2
C9h	MFR_SLOPE_CNT_10P	r/w	2
CAh	MFR_SLOPE_SR_9P	r/w	2
CBh	MFR_SLOPE_CNT_9P	r/w	2
CCh	MFR_SLOPE_SR_8P	r/w	2
CDh	MFR_SLOPE_CNT_8P	r/w	2
CEh	MFR_SLOPE_SR_7P	r/w	2
CFh	MFR_SLOPE_CNT_7P	r/w	2
D0h	MFR_SLOPE_SR_6P	r/w	2
D1h	MFR_SLOPE_CNT_6P	r/w	2
D2h	MFR_SLOPE_SR_5P	r/w	2
D3h	MFR_SLOPE_CNT_5P	r/w	2

PMBUS COMMANDS @ PAGE 0 (continued)

Command Code	Command Name	Type	Bytes
D4h	MFR_SLOPE_SR_4P	r/w	2
D5h	MFR_SLOPE_CNT_4P	r/w	2
D6h	MFR_SLOPE_SR_3P	r/w	2
D7h	MFR_SLOPE_CNT_3P	r/w	2
D8h	MFR_SLOPE_SR_2P	r/w	2
D9h	MFR_SLOPE_CNT_2P	r/w	2
DAh	MFR_SLOPE_SR_1P	r/w	2
DBh	MFR_SLOPE_CNT_1P	r/w	2
DDh	MFR_SLOPE_TRIM1	r/w	2
DEh	MFR_SLOPE_TRIM2	r/w	2
DFh	MFR_SLOPE_TRIM3	r/w	2
E0h	MFR_SLOPE_TRIM4	r/w	2
E1h	MFR_VR_CONFIG1	r/w	2
E2h	MFR_VR_CONFIG2	r/w	1
E3h	MFR_APS_LEVEL1	r/w	2
E4h	MFR_APS_LEVEL2	r/w	2
E5h	MFR_APS_LEVEL3	r/w	2
E6h	MFR_APS_LEVEL4	r/w	2
E7h	MFR_APS_LEVEL5	r/w	2
E8h	MFR_APS_HYS	r/w	1
E9h	MFR_TSNS_OT_SET	r/w	2
EAh	MFR_VTEMP_OT_SET	r/w	2
ECh	MFR_OCP_TOTAL	r/w	2
EDh	MFR_OCP_PHASE	r/w	1
EEh	MFR_OVP_UVP_SET	r/w	2
F8h	MFR_FAULTS1	r	2
F9h	MFR_FAULTS2	r	2
FAh	MFR_FAULTS3	r	2
FBh	MFR_FAULTS4	r	2
FFh	CLEAR_EEPROM_FAULTS	Send	0

PMBUS COMMANDS @ PAGE 29

Command Code	Command Name	Type	Bytes
FBh	MFR_LAST_FAULTS1	r/w	2
FCh	MFR_LAST_FAULTS2	r/w	2
FDh	MFR_LAST_FAULTS3	r/w	2
FEh	MFR_LAST_FAULTS4	r/w	2

PAGE 0 REGISTER MAP

PAGE (00h)

The PAGE command provides the ability to configure, control, and monitor all registers, including test mode and the EEPROM, through only one physical address.

Command	PAGE								
Format	Unsigned binary								
Bit	7	6	5	4	3	2	1	0	
Access	r/w	r/w	r/w	r/w	r/w	r/w	r/w	r/w	
Function	X	X	PAGE						

Bits	Bit Name	Description
7:6	RESERVED	Unused. X indicates that writes are ignored and reads are always 0.
5:0	PAGE	Register page selector. 00(hex): Page 0, all PMBus commands address normal function registers 02(hex): Page 2, all PMBus commands address test mode registers 28(hex): Page 28, all PMBus commands address EEPROM registers (00h~FFh) 29(hex): Page 29, all PMBus commands address EEPROM registers (100h~1FFh) EE_WORD_WR_EN = 1: Page 28/Page 29 is accessible EE_WORD_WR_EN = 0: Page 28/Page 29 is not accessible EE_WORD_WR_EN is bit[2] of MFR_EEPROM_CTRL (06h)

OPERATION (01h)

This register is used to turn the output on or off when EN is high. OPERATION is also used to set the output voltage to the upper or lower MARGIN voltages.

Command	OPERATION							
Format	Unsigned binary							
Bit	7	6	5	4	3	2	1	0
Access	r/w	r/w	r/w	r/w	r/w	r/w	r/w	r/w
Function	OPERATION_MODE							

Bits	Bit Name	Description
7:0	OPERATION_MODE	Operation mode. 00xxxxxx: Hi-Z off 01xxxxxx: soft off 1000xxxx: normal on 1001xxxx: margin low 1010xxxx: margin high The value of "x" does not matter.

CLEAR_FAULTS (03h)

The CLEAR_FAULTS command is used to clear any fault bits in all status registers (STATUS_BYTE, STATUS_WORD, STATUS_VOUT, STATUS_IOUT, STATUS_INPUT, STATUS_TEMPERATURE, and STATUS_CML).

This command is write only. There is no data byte for this command.

MFR_USER_PWD (04h)

This register presets the password for PMBus write protection.

Command	MFR_USER_PWD															
Format	Unsigned binary															
Bit	15	14	13	12	11	10	9	8	7	6	5	4	3	2	1	0
Access	w	w	w	w	w	w	w	w	w	w	w	w	w	w	w	w
Function	MFR_USER_PWD															

Bits	Bit Name	Description
16:0	MFR_USER_PWD	Password for PMBus write protection. Set password to 0x0000 for unprotected mode.

BUF_REG_UPD (05h)

Registers PHASE_CNT (E1h) and MFR_FS (BDh) are double-buffered. The BUF_REG_UPD command can update them on the fly simultaneously.

This command is write only. There is no data byte for this command.

MFR_EEPROM_CTRL (06h)

This register controls the memory behavior and selects the trim register for the ratio of I_{DROOP} / I_{CSSUM} to increase overall droop accuracy.

Command	MFR_EEPROM_CTRL								
Format	Unsigned binary								
Bit	7	6	5	4	3	2	1	0	
Access	r/w	r/w	r/w	r/w	r/w	r/w	r/w	r/w	
Function	x	x	x	IDROOP_TRIM_SEL					

Bits	Bit Name	Description																								
7:5	RESERVED	Unused. X indicates that writes are ignored and reads are always 0.																								
4:3	IDROOP_TRIM_SEL	<p>Trim register selector for the ratio of I_{DROOP} / I_{CSSUM}.</p> <p>00: select TRIM_IDROOP1 (9Ch) 01: select TRIM_IDROOP2 (9Dh) 10: select TRIM_IDROOP3 (9Eh) 11: select TRIM_IDROOP4 (9Fh)</p> <p>There are 16 types of ratios for I_{DROOP} / I_{CSSUM} divided into four groups. Each group has one trim value for corresponding ratios (see table below). The selection of the trim register must match IDROOP_SET in register 1Ch.</p> <table border="1" style="width: 100%; border-collapse: collapse;"> <thead> <tr> <th>IDROOP_SET</th> <th>Trim Register</th> <th>IDROOP_SET</th> <th>Trim Register</th> </tr> </thead> <tbody> <tr> <td>0 (0)</td> <td rowspan="4" style="text-align: center;">TRIM_IDROOP1 (9Ch)</td> <td>8 (12/64)</td> <td rowspan="4" style="text-align: center;">TRIM_IDROOP3 (9Eh)</td> </tr> <tr> <td>1 (5/64)</td> <td>9 (13/64)</td> </tr> <tr> <td>2 (6/64)</td> <td>10 (14/64)</td> </tr> <tr> <td>3 (7/64)</td> <td>11 (15/64)</td> </tr> <tr> <td>4 (8/64)</td> <td rowspan="4" style="text-align: center;">TRIM_IDROOP2 (9Dh)</td> <td>12 (16/64)</td> <td rowspan="4" style="text-align: center;">TRIM_IDROOP4 (9Fh)</td> </tr> <tr> <td>5 (9/64)</td> <td>13 (17/64)</td> </tr> <tr> <td>6 (10/64)</td> <td>14 (18/64)</td> </tr> <tr> <td>7 (11/64)</td> <td>15 (19/64)</td> </tr> </tbody> </table>	IDROOP_SET	Trim Register	IDROOP_SET	Trim Register	0 (0)	TRIM_IDROOP1 (9Ch)	8 (12/64)	TRIM_IDROOP3 (9Eh)	1 (5/64)	9 (13/64)	2 (6/64)	10 (14/64)	3 (7/64)	11 (15/64)	4 (8/64)	TRIM_IDROOP2 (9Dh)	12 (16/64)	TRIM_IDROOP4 (9Fh)	5 (9/64)	13 (17/64)	6 (10/64)	14 (18/64)	7 (11/64)	15 (19/64)
IDROOP_SET	Trim Register	IDROOP_SET	Trim Register																							
0 (0)	TRIM_IDROOP1 (9Ch)	8 (12/64)	TRIM_IDROOP3 (9Eh)																							
1 (5/64)		9 (13/64)																								
2 (6/64)		10 (14/64)																								
3 (7/64)		11 (15/64)																								
4 (8/64)	TRIM_IDROOP2 (9Dh)	12 (16/64)	TRIM_IDROOP4 (9Fh)																							
5 (9/64)		13 (17/64)																								
6 (10/64)		14 (18/64)																								
7 (11/64)		15 (19/64)																								

2	EE_WORD_WR_EN	Enable bit for writing and reading the EEPROM via the PMBus on Page 28/Page 29. 0: disable 1: enable
1	FAULT_SAVE_EN	Enable bit for auto-saving a fault status into the EEPROM. 0: disable 1: enable
0	CRC_PROTECT_EN	Enable bit for CRC fault protection. 0: EEPROM CRC fault does not stop the output power 1: EEPROM CRC fault stops the output power. The device enters shutdown mode. In the process of storing memory data into the EEPROM, the device calculates the CRC for all saved bits and saves the CRC result in the EEPROM. In the process of restoring the EEPROM data to the memory, the device calculates the CRC for all restored bits. At the end of the restore process, the device checks the CRC results saved in the EEPROM with the calculated CRC. If they do not match, the device reports a CRC fault and sets bit[4] of STATUS_CML (7Eh).

WRITE_PROTECT (13h)

This register is used to enable EEPROM write protection.

Command	WRITE_PROTECT							
Format	Unsigned binary							
Bit	7	6	5	4	3	2	1	0
Access	r/w	r/w	r/w	r/w	r/w	r/w	r/w	r/w
Function	EEPROM write protection							

Bits	Bit Name	Description
7:0	EEPROM_WP	Enable this bit for EEPROM write protection. 0x00: disable EEPROM write 0x63: enable EEPROM write

STORE_USER_ALL (15h)

The STORE_USER_ALL command instructs the PMBus device to copy the Page 0 contents of the operating memory to the matching locations in the EEPROM. In the process, the device calculates the CRC for all saved bits and saves the CRC result in the EEPROM.

This command is write only. There is no data byte for this command.

RESTORE_USER_ALL (16h)

The RESTORE_USER_ALL command instructs the PMBus device to copy the Page 0 contents from the EEPROM and overwrite the matching locations in the operating memory. In this process, the device calculates the CRC for all restored bits. If the calculated CRC does not match the CRC value saved in the EEPROM, the device reports the CRC error via bit[4] of register STATUS_CML (7Eh). The CRC error protect action is determined by bit[0] of MFR_EEPROM_CTRL (06h).

After the POR, the device triggers the memory copy operation from the EEPROM. This process is the same as the operating RESTORE_USER_ALL command.

It is *not* permitted to send this command while the device is outputting power; otherwise, the command will be ignored.

This command is write only. There is no data byte for this command.

MFR_DROOP_CMPN1 (1Ch)

This register is used to compensate for extra droop current for the linear upward DVID with a droop resistor.

Command	MFR_DROOP_CMPN1															
Format	Unsigned binary															
Bit	15	14	13	12	11	10	9	8	7	6	5	4	3	2	1	0
Access	r/w	r/w	r/w	r/w	r/w	r/w	r/w	r/w	r/w	r/w	r/w	r/w	r/w	r/w	r/w	r/w
Function	CNT_DROOP_CMPN_DEC						DROOP_CMPN_LIMIT									

Bits	Bit Name	Description
15	DROOP_CMPN_EN	Enable bit of the droop compensation for the upward DVID. 0: disable 1: enable
14:9	CNT_DROOP_CMPN_DEC	Interval time to decrease each step of droop compensation after the upward DVID. 50ns/LSB
8:6	CNT_DROOP_CMPN_INC	VID step counter for increasing each step of droop compensation during the upward DVID.
5:0	DROOP_CMPN_LIMIT	Maximum droop compensation value for upward DVID. 6.25mV/LSB.

MFR_DROOP_CMPN2 (1Dh)

This register is used to compensate for extra droop current for the linear upward DVID with a droop resistor and set the VID-DAC filter parameter.

Command	MFR_DROOP_CMPN2															
Format	Unsigned binary															
Bit	15	14	13	12	11	10	9	8	7	6	5	4	3	2	1	0
Access	r/w	r/w	r/w	r/w	r/w	r/w	r/w	r/w	r/w	r/w	r/w	r/w	r/w	r/w	r/w	r/w
Function	CNT_DROOP_CMPN_HOLD						DROOP_CMPN_FALL_THRE									

Bits	Bit Name	Description
15:14	VID_DAC_FLT_SEL	Time constant of the VID-DAC output filter for the downward DVID and steady state. 00: 2µs 01: 4µs 10: 6.5µs 11: 8.5µs
13	VID_FLT_EN	Enable bit of the VID-DAC output filter for the downward DVID and steady state. 0: disable 1: enable
12	DAC_CMPR_EN	Enable bit of the comparator of the VID-DAC output with its filtered voltage. 0: disable 1: enable
11:6	CNT_DROOP_CMPN_HOLD	Holding time before decreasing the droop compensation after the upward DVID. 50ns/LSB
5:0	DROOP_CMPN_FALL_THRE	Droop compensation falling threshold for reactivating the VID-DAC output filter. 6.25mV/LSB. Only effective when VID_FLT_EN = 1.

MFR_IDROOP_CTRL (1Eh)

This register sets the droop current gain and AC droop.

Command	MFR_IDROOP_CTRL							
Format	Unsigned binary							
Bit	7	6	5	4	3	2	1	0
Access	r/w	r/w	r/w	r/w	r/w	r/w	r/w	r/w
Function	x	x						IDROOP_SET

Bits	Bit Name	Description																																				
7:6	RESERVED	Unused. X indicates that writes are ignored and reads are always 0.																																				
5	AC_DROOP_EN	Enable bit of the AC droop loop. This loop eliminates the droop effect in steady state but keeps the droop effective during the load transient or DVID. 0: disable 1: enable																																				
4	AC_DROOP_LOOP_BW	Sets the bandwidth of the AC droop loop. This bit is only effective when AC_DROOP_EN = 1. 0: BW = 20kHz 1: BW = 40kHz																																				
3:0	IDROOP_SET	<table border="1"> <thead> <tr> <th>IDROOP_SET</th> <th>IdROOP / IcSSUM</th> <th>IDROOP_SET</th> <th>IdROOP / IcSSUM</th> </tr> </thead> <tbody> <tr><td>0</td><td>0</td><td>8</td><td>12/64</td></tr> <tr><td>1</td><td>5/64</td><td>9</td><td>13/64</td></tr> <tr><td>2</td><td>6/64</td><td>10</td><td>14/64</td></tr> <tr><td>3</td><td>7/64</td><td>11</td><td>15/64</td></tr> <tr><td>4</td><td>8/64</td><td>12</td><td>16/64</td></tr> <tr><td>5</td><td>9/64</td><td>13</td><td>17/64</td></tr> <tr><td>6</td><td>10/64</td><td>14</td><td>18/64</td></tr> <tr><td>7</td><td>11/64</td><td>15</td><td>19/64</td></tr> </tbody> </table>	IDROOP_SET	IdROOP / IcSSUM	IDROOP_SET	IdROOP / IcSSUM	0	0	8	12/64	1	5/64	9	13/64	2	6/64	10	14/64	3	7/64	11	15/64	4	8/64	12	16/64	5	9/64	13	17/64	6	10/64	14	18/64	7	11/64	15	19/64
IDROOP_SET	IdROOP / IcSSUM	IDROOP_SET	IdROOP / IcSSUM																																			
0	0	8	12/64																																			
1	5/64	9	13/64																																			
2	6/64	10	14/64																																			
3	7/64	11	15/64																																			
4	8/64	12	16/64																																			
5	9/64	13	17/64																																			
6	10/64	14	18/64																																			
7	11/64	15	19/64																																			

VOUT_MIN (1Fh)

This register sets the minimum voltage setting for both PWM-VID mode and PMBus VID override mode.

Command	VOUT_MIN															
Format	VID															
Bit	15	14	13	12	11	10	9	8	7	6	5	4	3	2	1	0
Access	r/w	r/w	r/w	r/w	r/w	r/w	r/w	r/w	r/w	r/w	r/w	r/w	r/w	r/w	r/w	r/w
Function	x	x	x	x	x	x	x									VOUT_MIN

Bits	Bit Name	Description
15:9	RESERVED	Unused. X indicates that writes are ignored and reads are always 0.
8:0	VOUT_MIN	Minimum voltage setting. Any setting smaller than this value is clamped. This is the target VID when the pulse duty from PWM-VID is zero. 6.25mV/LSB.

VOUT_COMMAND (21h)

This register is used to set the output voltage on the fly for PMBus VID override mode.

Command	VOUT_COMMAND															
Format	VID															
Bit	15	14	13	12	11	10	9	8	7	6	5	4	3	2	1	0
Access	r/w	r/w	r/w	r/w	r/w	r/w	r/w	r/w	r/w	r/w	r/w	r/w	r/w	r/w	r/w	r/w
Function	x	x	x	x	x	x	x									VOUT_COMMAND

Bits	Bit Name	Description
15:9	RESERVED	Unused. X indicates that writes are ignored and reads are always 0.
8:0	VOUT_COMMAND	Output voltage for PMBus VID override mode. 6.25mV/LSB.

VOUT_OFFSET (23h)

This register is used to set the output voltage offset from the VID target for PMBus VID override mode.

Command	VOUT_OFFSET															
Format	VID															
Bit	15	14	13	12	11	10	9	8	7	6	5	4	3	2	1	0
Access	r/w	r/w	r/w	r/w	r/w	r/w	r/w	r/w	r/w	r/w	r/w	r/w	r/w	r/w	r/w	r/w
Function	x	x	x	x	x	x	x	x	VOUT_OFFSET							

Bits	Bit Name	Description
15:8	RESERVED	Unused. X indicates that writes are ignored and reads are always 0.
7:0	VOUT_OFFSET	Output voltage offset on the VID reference. 6.25mV/LSB. This value is in two's complement binary format. Bit[7] is the sign bit.

VOUT_MAX (24h)

This register sets the maximum voltage setting for both PWM-VID mode and PMBus VID override mode.

Command	VOUT_MAX															
Format	VID															
Bit	15	14	13	12	11	10	9	8	7	6	5	4	3	2	1	0
Access	r/w	r/w	r/w	r/w	r/w	r/w	r/w	r/w	r/w	r/w	r/w	r/w	r/w	r/w	r/w	r/w
Function	x	x	x	x	x	x	x	VOUT_MAX								

Bits	Bit Name	Description
15:9	RESERVED	Unused. X indicates that writes are ignored reads are always 0.
8:0	VOUT_MAX	Maximum voltage setting. Any setting higher than this value is clamped. In PWM-VID mode, this is the target VID when the pulse duty PWM-VID pin is 100%. In PMBus VID override mode, the OVP1 level is VOUT_MAX + 400mV. 6.25mV/LSB.

VOUT_MARGIN_HIGH (25h)

This register sets the output voltage when the OPERATION (01h) is set to margin high. VID format.

Command	VOUT_MARGIN_HIGH															
Format	VID															
Bit	15	14	13	12	11	10	9	8	7	6	5	4	3	2	1	0
Access	r/w	r/w	r/w	r/w	r/w	r/w	r/w	r/w	r/w	r/w	r/w	r/w	r/w	r/w	r/w	r/w
Function	x	x	x	x	x	x	x	VOUT_MARGIN_HIGH								

Bits	Bit Name	Description
15:9	RESERVED	Unused. X indicates that writes are ignored and reads are always 0.
8:0	VOUT_MARGIN_HIGH	Sets the output voltage for the PMBus margin high mode. 6.25mV/LSB.

VOUT_MARGIN_LOW (26h)

This register sets the output voltage when OPERATION (01h) is set to margin low. VID format.

Command	VOUT_MARGIN_LOW															
Format	VID															
Bit	15	14	13	12	11	10	9	8	7	6	5	4	3	2	1	0
Access	r/w	r/w	r/w	r/w	r/w	r/w	r/w	r/w	r/w	r/w	r/w	r/w	r/w	r/w	r/w	r/w
Function	x	x	x	x	x	x	x	VOUT_MARGIN_LOW								

Bits	Bit Name	Description
15:9	RESERVED	Unused. X indicates that writes are ignored and reads are always 0.
8:0	VOUT_MARGIN_LOW	Sets the output voltage for PMBus margin low mode. 6.25mV/LSB.

VENDOR_ID_USER (27h)

This register sets the vendor ID for users.

Command	VENDOR_ID_USER							
Format	Unsigned binary							
Bit	7	6	5	4	3	2	1	0
Access	r/w	r/w	r/w	r/w	r/w	r/w	r/w	r/w
Function	VENDOR_ID_USER							

Bits	Bit Name	Description
7:0	VENDOR_ID_USER	Vendor ID for users. 0x25 represents MPS Corporation.

PRODUCT_ID_USER (28h)

This register sets the product ID for users.

Command	PRODUCT_ID_USER							
Format	Unsigned binary							
BIT	7	6	5	4	3	2	1	0
Access	r/w	r/w	r/w	r/w	r/w	r/w	r/w	r/w
Function	PRODUCT_ID_USER							

Bits	Bit Name	Description
7:0	PRODUCT_ID_USER	Product ID for users. 0x84 represents the MP2884A.

PRODUCT_REV_USER (29h)

This register configures the file code revision.

Command	PRODUCT_REV_USER							
Format	Unsigned binary							
Bit	7	6	5	4	3	2	1	0
Access	r/w	r/w	r/w	r/w	r/w	r/w	r/w	r/w
Function	PRODUCT_REV_USER							

Bits	Bit Name	Description
7:0	PRODUCT_REV_USER	Configure file code revision.

MFR_DC_DIV_SET (2Ah)

This register sets the output voltage sensing.

Command	MFR_DC_DIV_SET															
Format	Unsigned binary															
Bit	15	14	13	12	11	10	9	8	7	6	5	4	3	2	1	0
Access	r/w	r/w	r/w	r/w	r/w	r/w	r/w	r/w	r/w	r/w	r/w	r/w	r/w	r/w	r/w	r/w
Function	x	x														VOUT_SCALE

Bits	Bit Name	Description
15:14	RESERVED	Unused. X indicates that writes are ignored and reads are always 0.
13	DC_LOOP_SNS_SEL	DC loop feedback selector. 0: VFB 1: VDIFF
12	DC_LOOP_REF_SEL	DC loop reference accuracy selector. 0: with 2-bit fraction 1: without 2-bit fraction
11	VDIFF_GAIN_SEL	Gain selector for the remote sense amplifier. 0: unity gain. VOUT is limited to 1.6V. The DC loop regulation has 1.5625mV resolution. 1: half gain. VOUT can be set to 3.19375V. The DC loop regulation has 3.125mV resolution.
10:9	DIFF_FB_SENSE_GAIN	ADC sensing gain selector for VDIFF and VFB. 00: half gain 01: unity gain 10: three-quarter gain 11: invalid When VDIFF_GAIN_SEL = 1, the DIFF_FB_SENSE_GAIN is forced to half the gain of the inner MP2884A.
8:0	VOUT_SCALE	Calculated scale factor consistent with the gain of the external output voltage divider. $VOUT_SCALE = 32 \times VOUT/VOUT_SENSE$.

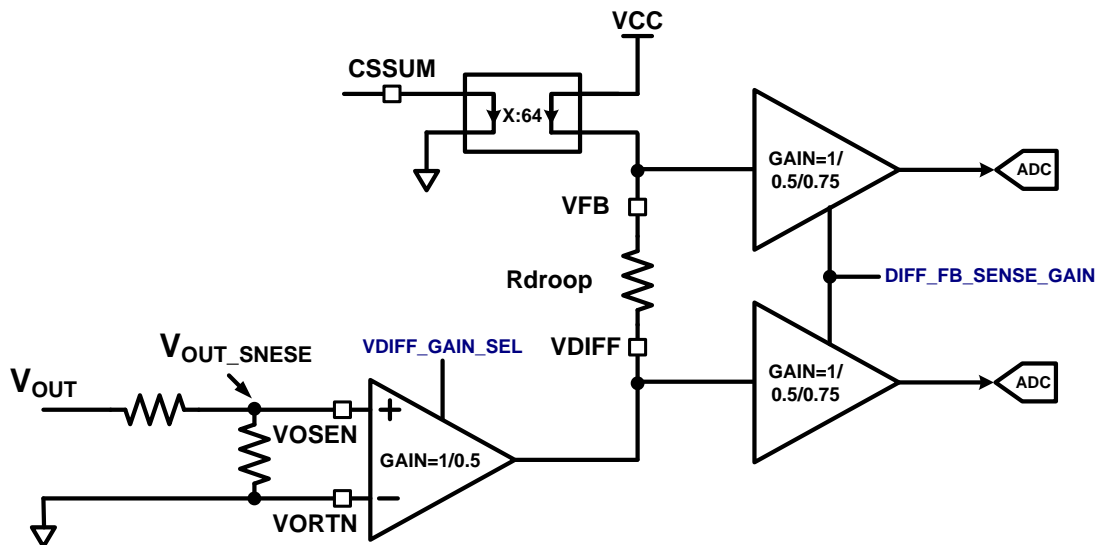
Figure 18: DC Loop Gain Selection Block Diagram

MFR_IDROOP_OFFSET (2Bh)

This register sets an additional offset on the droop current.

Command	MFR_IDROOP_OFFSET							
Format	Signed binary							
Bit	7	6	5	4	3	2	1	0
Access	r/w	r/w	r/w	r/w	r/w	r/w	r/w	r/w
Function	x	x	IDROOP_OFFSET					

Bits	Bit Name	Description
7:6	RESERVED	Unused. X indicates that writes are ignored and reads are always 0.
5:0	IDROOP_OFFSET	User offset on the droop current. 0.81µA/LSB. This value is in two's complement binary format. Bit[5] is the sign bit.

MFR_OVUV_SEL (2Ch)

This register sets the output voltage OVP2 and UVP2 level.

Command	MFR_OVUV_SEL															
Format	binary															
Bit	15	14	13	12	11	10	9	8	7	6	5	4	3	2	1	0
Access	r/w	r/w	r/w	r/w	r/w	r/w	r/w	r/w	r/w	r/w	r/w	r/w	r/w	r/w	r/w	r/w
Function	x	x	x	x	x	x	x			1			1	OVUV_LEVEL		

Bits	Bit Name	Description
15:9	RESERVED	Unused. X indicates that writes are ignored and reads are always 0.
8:7	TRIM_UVP2_OFFSET	Trimming value of UVP2 offset. Factory settings. Do not change.
6	RESERVED	Fixed to 1.
5:4	TRIM_OVP2_OFFSET	Trimming value of OVP2 offset. Factory settings. Do not change.
3	RESERVED	Fixed to 1.
2:0	OVUV_LEVEL	<p>OVP2 and UVP2 level.</p> <p>001: 190mV 010: 310mV 100: 430mV others: invalid</p> <p>If the remote sense amplifier sets the unity gain, then the OVP2 level is VREF + OVUV_LEVEL. The UVP2 level is VREF - OVUV_LEVEL.</p> <p>If the remote sense amplifier sets the half gain, then the OVP2 level is VREF + OVUV_LEVELx2. The UVP2 level is VREF - OVUV_LEVELx2.</p>

MFR_RSAMP_OFFSET (2Dh)

This register is used to apply an offset to the remote sense amplifier. This is used to fine-tune the output voltage offset.

Command	MFR_RSAMP_OFFSET							
Format	Signed binary							
Bit	7	6	5	4	3	2	1	0
Access	r/w	r/w	r/w	r/w	r/w	r/w	r/w	r/w
Function	x	RSAMP_OFFSET						

Bits	Bit Name	Description
7	RESERVED	Unused. X indicates that writes are ignored and reads are always 0.
6:0	RSAMP_OFFSET	Offset on the remote sense amplifier. This value is in two's complement binary format. Bit[6] is the sign bit. If the remote sense amplifier sets the unity gain, the resolution is 0.5mV/LSB. If the remote sense amplifier sets the half gain, the resolution is 0.8mV/LSB.

MFR_VFB_DIGI_GAIN (2Eh)

This register sets a digital gain to fine-tune the VFB sense value for the DC loop.

Command	MFR_VFB_DIGI_GAIN															
Format	Unsigned binary															
Bit	15	14	13	12	11	10	9	8	7	6	5	4	3	2	1	0
Access	r/w	r/w	r/w	r/w	r/w	r/w	r/w	r/w	r/w	r/w	r/w	r/w	r/w	r/w	r/w	r/w
Function	x	x	x	x	x	VFB_DIGI_GAIN										

Bits	Bit Name	Description
15:11	RESERVED	Unused. X indicates that writes are ignored and reads are always 0.
10:0	VFB_DIGI_GAIN	Multiplies the VFB ADC sense value by the digital gain. The result is used for the DC loop. Default value is 1024 for the unity gain. $VFB_SENSE_FINAL = VFB_ADC \times VFB_DIGI_GAIN / 1024$

MFR_IMON_DIGI_GAIN (2Fh)

This register sets a digital gain used to fine-tune the IMON sense value for the output current report.

Command	MFR_IMON_DIGI_GAIN															
Format	Unsigned binary															
Bit	15	14	13	12	11	10	9	8	7	6	5	4	3	2	1	0
Access	r/w	r/w	r/w	r/w	r/w	r/w	r/w	r/w	r/w	r/w	r/w	r/w	r/w	r/w	r/w	r/w
Function	x	x	x	x	x	IMON_DIGI_GAIN										

Bits	Bit Name	Description
15:11	RESERVED	Unused. X indicates that writes are ignored and reads are always 0.
10:0	IMON_DIGI_GAIN	Multiplies the IMON ADC sense value by the digital gain. The result is used for output current reporting. The default value is 1024 for the unity gain. $IMON_SENSE_FINAL = IMON_ADC \times IMON_DIGI_GAIN / 1024$

MFR_DC_LOOP_CTRL (30h)

This register sets the output voltage DC loop performance and sets the power mode when adding phases during the transient.

Command	MFR_DC_LOOP_CTRL															
Format	Unsigned binary															
Bit	15	14	13	12	11	10	9	8	7	6	5	4	3	2	1	0
Access	r/w	r/w	r/w	r/w	r/w	r/w	r/w	r/w	r/w	r/w	r/w	r/w	r/w	r/w	r/w	r/w
Function	PWM_PRD_ERROR_THRE										DC_LOOP_HOLD_TIME					

Bits	Bit Name	Description
15	FREQ_ADD_PHASE_MODE	Mode selector for adding phases due to the PWM frequency increasing. When the controller runs in auto-phase shedding mode, it enters full-phase CCM if it detects that the PWM frequency has risen higher than the setting limit due to the load increasing. 0: idle PWMs switch from Hi-Z to low 1: idle PWMs switch from Hi-Z to high
14	UV_ADD_PHASE_MODE	Mode selector for adding phases due to VFB dropping. When the controller runs in auto-phase-shedding mode, it enters full-phase CCM if it detects that VFB has dropped below VO_REF - 25mV due to the load increasing. 0: idle PWMs switch from Hi-Z to low 1: idle PWMs switch from Hi-Z to high
13:7	PWM_PRD_ERROR_THRE	PWM period error threshold for holding the DC loop and current balance loop. When the actual PWM period has a deviation from the configured period, either the positive or negative deviation exceeds this threshold. The DC loop and current balance loop are held. 80ns/LSB.
6	PRD_HOLD_DC_EN	Enable bit for holding the DC loop for a certain amount of time when the error of the PWM period exceeds the threshold PWM_PRD_ERROR_THRE. 0: disable 1: enable This function needs another condition. See MFR_PWM_LIMIT (3Fh) bit[10:7].
5	PHASE_CNT_HOLD_DC_EN	Enable bit for holding the DC loop for a certain amount of time when the phase-count changes. 0: disable 1: enable
4	VFB_HOLD_DC_EN	Enable bit for holding the DC loop for a certain amount of time when VFB exceeds the VO_REF - 25mV or VO_REF + 20mV threshold. 0: disable 1: enable
3:0	DC_LOOP_HOLD_TIME	DC loop holding time. 100µs/LSB.

MFR_CB_LOOP_CTRL (31h)

This register sets the current balance (CB) loop performance.

Command	MFR_CB_LOOP_CTRL							
Format	Unsigned binary							
Bit	7	6	5	4	3	2	1	0
Access	r/w	r/w	r/w	r/w	r/w	r/w	r/w	r/w
Function						CB_LOOP_HOLD_TIME		

Bits	Bit Name	Description
7	VFB_HOLD_CB_EN	Enable bit for holding the CB loop for a certain amount of time when VFB exceeds the VO_REF - 25mV or VO_REF + 20mV threshold. 0: disable 1: enable
6	PRD_HOLD_CB_EN	Enable bit for holding the CB loop for a certain amount of time when the error of the PWM period exceeds the threshold PWM_PRD_ERROR_THRE. 0: disable 1: enable

5	PHASE_CNT_HOLD_CB_EN	Enable bit for holding the CB loop for a certain amount of time when the phase count changes. 0: disable 1: enable
4	DVID_HOLD_CB_EN	Enable bit for holding the CB loop for a certain amount of time during DVID. 0: disable 1: enable
3:0	CB_LOOP_HOLD_TIME	Current balance loop holding time. 100µs/LSB.

MFR_FS_LOOP_CTRL (32h)

This register is used for PWM frequency loop setting.

Command	MFR_FS_LOOP_CTRL															
Format	Unsigned binary															
Bit	15	14	13	12	11	10	9	8	7	6	5	4	3	2	1	0
Access	r/w	r/w	r/w	r/w	r/w	r/w	r/w	r/w	r/w	r/w	r/w	r/w	r/w	r/w	r/w	r/w
Function	x				FS_LOOP_HOLD_TIME				FS_LOOP_KI							

Bits	Bit Name	Description
15	RESERVED	Unused. X indicates that writes are ignored and always read as 0.
14	VFB_HOLD_FS_EN	Enable bit for holding the frequency loop for a certain amount of time when VFB exceeds the VO_REF - 25mV or VO_REF + 20mV threshold. 0: disable 1: enable
13	PHASE_CNT_HOLD_FS_EN	Enable bit for holding the frequency loop for a certain amount of time when the phase count changes. 0: disable 1: enable
12	DVID_HOLD_FS_EN	Enable bit for holding the frequency loop for a certain amount of time during DVID. 0: disable 1: enable
11:8	FS_LOOP_HOLD_TIME	Frequency loop holding time. 100µs/LSB.
7	FS_LOOP_EN	Enable bit for the PWM frequency loop. 0: disable 1: enable
6:0	FS_LOOP_KI	PWM frequency loop integral parameter.

MFR_T_ALERT_CTRL (34h)

This register sets the thermal alert pin (TALERT#) behavior.

Command	MFR_T_ALERT_CTRL															
Format	Unsigned binary															
Bit	15	14	13	12	11	10	9	8	7	6	5	4	3	2	1	0
Access	r/w	r/w	r/w	r/w	r/w	r/w	r/w	r/w	r/w	r/w	r/w	r/w	r/w	r/w	r/w	r/w
Function	x	x	T_ALT_DELAY						TSNS_T_ALT_THRE							

Bits	Bit Name	Description
15:14	RESERVED	Unused. X indicates that writes are ignored and reads are always 0.
13:11	T_ALT_DELAY	Trigger delay time for pulling TALER# low. 100µs/LSB.
10	TSNS_CURRENT_DIS	Enable bit for sourcing a 10µA constant current from TSNS to the thermistor to generate a voltage for the temperature sensing. 0: enable 1: disable
9	TSNS_T_ALT_EN	Enable bit for pulling TALER# low when the controller detects an over-temperature warning from TSNS. 0: disable 1: enable
8	TEMP_T_ALT_EN	Enable bit for pulling TALER# low when the controller detects an over-temperature warning from VTEMP. 0: disable 1: enable
7:0	TSNS_T_ALT_THRE	Digital threshold of the over-temperature warning from TSNS. $TSNS_T_ALT_THRE = R_t \times 10\mu A \times 256 / 1.6V$

VIN_ON (35h)

This register sets the input voltage UVLO rising threshold. When the input voltage rises higher than VIN_ON, the MP2884A soft starts to the boot voltage with a programmed slew rate.

Command	VIN_ON															
Format	Linear, two's complement binary															
Bit	15	14	13	12	11	10	9	8	7	6	5	4	3	2	1	0
Access	r/w	r/w	r/w	r/w	r/w	r/w	r/w	r/w	r/w	r/w	r/w	r/w	r/w	r/w	r/w	r/w
Function	Exponent					x			Mantissa							

Bits	Bit Name	Description
15:11	Exponent	This value is two's complement binary format and fixed to 11101. Exponent = -3 (fixed)
10:8	RESERVED	Unused. X indicates that writes are ignored and reads are always 0.
7:0	Mantissa	Input voltage UVLO rising threshold. 0.125V/LSB. $VIN_ON = Mantissa \times 2^{exponent} = Mantissa \times 0.125$

VIN_OFF (36h)

This register sets the input voltage UVLO falling threshold. When the input voltage falls below VIN_OFF, all PWMs enter tri-state mode, and the VR shuts down.

Command	VIN_OFF															
Format	Linear, two's complement binary															
Bit	15	14	13	12	11	10	9	8	7	6	5	4	3	2	1	0
Access	r/w	r/w	r/w	r/w	r/w	r/w	r/w	r/w	r/w	r/w	r/w	r/w	r/w	r/w	r/w	r/w
Function	Exponent					x			Mantissa							

Bits	Bit Name	Description
15:11	Exponent	This value is two's complement binary format and fixed to 11101. Exponent = -3 (fixed)
10:8	RESERVED	Unused. X indicates that writes are ignored and always read as 0.
7:0	Mantissa	Input voltage UVLO falling threshold. 0.125V/LSB. VIN_OFF = Mantissa × 2 ^{exponent} = Mantissa × 0.125

IOUT_CAL_GAIN (38h)

This register sets the gain for the total current report in the READ_IOUT register. This is the ratio of the IMON voltage to the total output current. This is related to the DrMOS current sense gain (Kcs) and IMON current sense resistor (R_{IMON}).

Command	IOUT_CAL_GAIN															
Format	Linear, two's complement binary															
Bit	15	14	13	12	11	10	9	8	7	6	5	4	3	2	1	0
Access	r/w	r/w	r/w	r/w	r/w	r/w	r/w	r/w	r/w	r/w	r/w	r/w	r/w	r/w	r/w	r/w
Function	Exponent						Mantissa									

Bits	Bit Name	Description
15:11	Exponent	This value is in two's complement binary format. 10001: exponent = -15 10010: exponent = -14 10011: exponent = -13 others: invalid
10:0	Mantissa	$\text{Mantissa} = \frac{V_{\text{IMON}}}{I_{\text{OUT}}} \times 2^{-\text{exponent}} = \frac{K_{\text{CS}} \times R_{\text{IMON}}}{16000} \times 2^{-\text{exponent}}$ <p>Where V_{IMON} is the voltage of IMON, I_{OUT} is the total output current, R_{IMON} is the resistor connected from IMON to ground (in kΩ), and K_{CS} is the current sense gain of the DrMOS (in μA/A).</p> <p>When R_{IMON} is too big for Mantissa < 2¹¹, increase the exponent. This usually meets small load-current applications.</p> <p>If TOTAL_CURRENT_RESOLUTION (44h) = 1, then IOUT_CAL_GAIN must be doubled.</p>

IOUT_CAL_OFFSET (39h)

This register is used to set the offset for the total current report in READ_IOUT.

Command	IOUT_CAL_OFFSET															
Format	Linear, two's complement binary															
Bit	15	14	13	12	11	10	9	8	7	6	5	4	3	2	1	0
Access	r/w	r/w	r/w	r/w	r/w	r/w	r/w	r/w	r/w	r/w	r/w	r/w	r/w	r/w	r/w	r/w
Function	Exponent						x		Mantissa							

Bits	Bit Name	Description
15:10	Exponent	This value is in two's complement binary format (fixed at 111100). Exponent = -2 (fixed)
9:7	RESERVED	Unused. X indicates that writes are ignored and reads are always 0.

6:0	Mantissa	$I_{OUT_CAL_OFFSET} = \text{Mantissa} \times 2^{\text{exponent}} = \text{Mantissa} \times 0.25$ 0.25A/LSB (TOTAL_CURRENT_RESOLUTION = 0) 0.5A/LSB (TOTAL_CURRENT_RESOLUTION = 1) This value is in two's complement binary format. Bit[6] is the sign bit.
-----	----------	--

MFR_PROTECT_DIS (3Ah)

This register is used for protection selection.

Command	MFR_PROTECT_DIS															
Format	Unsigned binary															
Bit	15	14	13	12	11	10	9	8	7	6	5	4	3	2	1	0
Access	r/w	r/w	r/w	r/w	r/w	r/w	r/w	r/w	r/w	r/w	r/w	r/w	r/w	r/w	r/w	r/w
Function	x	x	x	x	x										OVP1_DIS	OTP_DIS

Bits	Bit Name	Description
15:11	RESERVED	Unused. X indicates that writes are ignored and reads are always 0.
10	PWM_CHK_FAULT_EN	Enable bit for ADC sampling of the Intelli-Phase PWM once a protection occurs. In this process, all PWM outputs remain in Hi-Z status. 0: disable 1: enable
9	CS_FAULT_EN	Enable bit for CSx fault protection from CS. Voltage on any CS pin falling below 0.3V can trigger CSx fault protection and latch the controller. 0: disable 1: enable
8	TEMP_FAULT_EN	Enable bit for VTEMP fault protection from VTEMP. Voltage on VTEMP exceeding a certain threshold can trigger VTEMP fault protection and latch the controller. 0: disable 1: enable
7	TEMP_FAULT_BLOCK_OTP	Enable bit for blocking OTP when a VTEMP fault protection is triggered. 0: enable 1: disable
6	DVID_BLOCK_OVP1	Enable bit for blocking the output voltage OVP1 during DVID. 0: disable 1: enable
5:4	VIN_PROTECT_DIS	Enable bits for the input voltage UVLO and OVP. 11: disable others: enable
3:2	OVP1_DIS	Enable bits for the output voltage OVP1. 01: disable others: enable
1:0	OTP_DIS	Enable bits for OTP from VTEMP. 01: disable others: enable

MFR_PS_FORCE (3Bh)

This register is used to set advanced functions of the controller, such as forced power state, and related parameters.

Command	MFR_PS_FORCE															
Format	Unsigned binary															
Bit	15	14	13	12	11	10	9	8	7	6	5	4	3	2	1	0
Access	r/w	r/w	r/w	r/w	r/w	r/w	r/w	r/w	r/w	r/w	r/w	r/w	r/w	r/w	r/w	r/w
Function			x			x	x			x			TRI_STATE_DELAY			

Bits	Bit Name	Description
15	PSI_CONTROL	0: jump to full-phase during soft start and DVID, even if PSI is low 1: follow PSI to reach the target phase-count during soft start and DVID
14	PWM_TRI_MODE	PWM tri-state mode selector. 0: Hi-Z 1: force 1.5V middle voltage
13	RESERVED	Unused. X indicates that writes are ignored and reads are always 0.
12	VIN_MUX_SEL	V _{IN} value mode selector for T _{ON} calculation. 0: real-time V _{IN} 1: latched V _{IN}
11	PROTECT_ALL_DIS	Master enable bit for all protections. 0: enable protection 1: disable all protection
10:9	RESERVED	Unused. X indicates that writes are ignored and reads are always 2'b11.
8	VIN2TON_EN	Enable bit for updating T _{ON} when V _{IN} varies or moves away from the previous latched V _{IN} value. 0: disable 1: enable
7	DLL_EN	Enable bit of DLL. DLL can increase the PWM resolution to 0.625ns/LSB. 0: disable 1: enable
6	RESERVED	Unused. X indicates that writes are ignored and reads are always 1.
5	IOUT_FILTER_SET	Output current reporting mode selector. 0: average I _{OUT} report 1: real-time I _{OUT} report
4:0	TRI_STATE_DELAY	PWM low-time inserted between PWM high and tri-state when the PWM logic changes from high-state to middle-state. 5ns/LSB.

MFR_SLOPE_ADV (3Dh)

This register is used for advanced slope compensation setting.

Command	MFR_SLOPE_ADV															
Format	Unsigned binary															
Bit	15	14	13	12	11	10	9	8	7	6	5	4	3	2	1	0
Access	r/w	r/w	r/w	r/w	r/w	r/w	r/w	r/w	r/w	r/w	r/w	r/w	r/w	r/w	r/w	r/w
Function	x						INI_SLOPE_CURRENT									

Bits	Bit Name	Description
15	RESERVED	Unused. X indicates that writes are ignored and reads are always 0.
14	SS_PHASE_CUR_LIMIT_EN	Enable bit of the per-phase valley current limit during soft start.
13:12	OC_SKIP_PHASE_TIME	Trigger delay time for phase skipping when a certain phase triggers the phase current limit. 20ns/LSB with 15ns offset. When a certain phase's current is above the phase current limit, its PWM high logic is delayed until the current drops below the limitation. If the delay time is reached, this phase's PWM high logic is passed to the next phase.
11	INI_SLOPE_EN	Enable bit of the initial slope compensation before the first PWM during soft start. 0: disable 1: enable If enabled, the initial slope slew rate is set via INI_SLOPE_CURRENT.
10:5	INI_SLOPE_CURRENT	Current source value for initial slope compensation before the first PWM during soft start. 0.25µA/LSB. $V_{\text{SLOPE@INI}} = \frac{\text{INI_SLOPE_CURRENT}}{16 \times 1.85(\text{pF})} \times T_{\text{charge}}(\text{us})$ The maximum charging time is 0.4µs.
4	SLOPE_BLANK_SEL	Slope compensation blank time selector. 0: use the calculated T _{ON} 1: use register SLOPE_BLANK_TIME The blank time starts when the PWM rises high. During the blank time, the slope compensation capacitor is discharged.
3	PRE_BIAS_MODE	Mode selector for idle PWMs to exit tri-state during phase-adding. 0: idle PWMs rise high from tri-state when their own high logic comes 1: all idle PWMs drop low from tri-state when the first high logic of any phase comes. This high logic phase's PWM rises high directly.
2	EXIT_DCM_SLOPE_MODE	Mode selector of the first CCM compensating slope when the controller exits DCM. 0: first CCM slope rises on the base of the DCM slope voltage 1: first CCM slope rises after clearing the DCM slope voltage
1	DCM_SLOPE_CLAMP	Enable bit of the 60mV maximum limit for DCM slope compensation. 0: disable 1: enable
0	SLOPE_SWITCH_OFF_EN	Enable bit for turning off the low leakage switch when the slope compensation current source turns off. The low leakage switch is in series with the capacitor and current source of slope compensation. 0: disable 1: enable

MFR_PWM_LIMIT (3Fh)

This register sets the PWM minimum on time and minimum off time.

Command	MFR_PWM_LIMIT															
Format	Unsigned binary															
Bit	15	14	13	12	11	10	9	8	7	6	5	4	3	2	1	0
Access	r/w	r/w	r/w	r/w	r/w	r/w	r/w	r/w	r/w	r/w	r/w	r/w	r/w	r/w	r/w	r/w
Function	x	x	x	x	x	ON_TIME_LIMIT			MIN_ON_TIME			MIN_OFF_TIME				

Bits	Bit Name	Description
15:11	RESERVED	Unused. X indicates that writes are ignored and reads are always 0.
10:7	ON_TIME_LIMIT	PWM on-time threshold for the DC loop hold function. This is another condition for the function of holding the DC loop via an error of the PWM period. If the calculated T_{ON} is less than this threshold, the DC loop cannot be held via the PWM period, even if bit[6] of MFR_DC_LOOP_CTRL (30h) is set. 5ns/LSB.
6:4	MIN_ON_TIME	PWM minimum on time. 5ns/LSB.
3:0	MIN_OFF_TIME	PWM minimum off time. 20ns/LSB with 15ns offset.

MFR_OSR_SET (40h)

This register sets the minimum PWM off-time and block time of the OSR function.

Command	MFR_OSR_SET															
Format	Unsigned binary															
Bit	15	14	13	12	11	10	9	8	7	6	5	4	3	2	1	0
Access	r/w	r/w	r/w	r/w	r/w	r/w	r/w	r/w	r/w	r/w	r/w	r/w	r/w	r/w	r/w	r/w
Function	x	x	OSR_DEGLITCH_TIME					OSR_BLOCK_TIME								

Bits	Bit Name	Description
15:14	RESERVED	Unused. X indicates that writes are ignored and reads are always 0.
13:8	OSR_DEGLITCH_TIME	Minimum PWM off time in the OSR process. 5ns/LSB.
7:0	OSR_BLOCK_TIME	Block time between two OSR events. 5ns/LSB.

MFR_T_ALERT_CTRL2 (43h)

This register sets thermal alert pin (TALERT#) behavior.

Command	MFR_T_ALERT_CTRL2															
Format	Unsigned binary															
Bit	15	14	13	12	11	10	9	8	7	6	5	4	3	2	1	0
Access	r/w	r/w	r/w	r/w	r/w	r/w	r/w	r/w	r/w	r/w	r/w	r/w	r/w	r/w	r/w	r/w
Function	x	x	x	x	x	x	x									

Bits	Bit Name	Description
15:9	RESERVED	Unused. X indicates that writes are ignored and reads are always 0.
8	TSNS_RES_SEL	Type selection bit of TSNS thermistor. 0: PTC 1: NTC

7:4	TSNS_T_ALT_DST_THRE	Digital threshold of the over-temperature warning de-assertion from TSNS. TSNS_T_ALT_DST_THRE = $R_{t_dst} \times 10\mu\text{A} \times 16 / 1.6\text{V}$
3:0	OT_WARN_DST_THRE	Digital threshold of the over-temperature warning deassertion from VTEMP. 16°C/LSB.

MFR_SYS_CONFIG (44h)

This register sets the system configuration.

Command	MFR_SYS_CONFIG															
Format	Unsigned binary															
Bit	15	14	13	12	11	10	9	8	7	6	5	4	3	2	1	0
Access	r/w	r/w	r/w	r/w	r/w	r/w	r/w	r/w	r/w	r/w	r/w	r/w	r/w	r/w	r/w	r/w
Function											x					

Bits	Bit Name	Description
15:12	DGTL_UVP_LEVEL	Threshold of digital Vo_UVP. 32mV/LSB
11	DGTL_UVP_EN	Enable bit of digital Vo_UVP. 0: disable 1: enable
10	OC_BLK_UVP_EN	Enable bit for blocking analog Vo_UVP when any phase's current reaches the per-phase-valley-current limit (the internal OC signal rises high). 1: block 0: do not block
9	ANA_UVP_DIS	Enable bit of analog Vo_UVP. 1: disable 0: enable
8:7	OC_DGLTCH_FOR_DGTL_UVP	Deglitch time of the internal OC signal which is boolean and with a digital UV signal to trigger digital Vo_UVP. 00: 800ns 01: 1000ns 10: 1200ns 11: force the internal OC signal high
6	AC_LL_ACTIVATE_MODE	AC droop loop activation mode. 1: activate AC Droop loop when soft-start begins. 0: activate AC Droop loop once the controller finishes POR.
5	RESERVED	Unused. X indicates that writes are ignored and reads are always 0.
4	PHASE_CURRENT_RESOLUTION	Resolution selector for per-phase current report and protection. 0: original resolution 1: half resolution (double range)
3	TOTAL_CURRENT_RESOLUTION	Resolution selector for total current report, protection, warning, and auto-phase shedding (APS) levels. 0: original resolution 1: half resolution (double range)

2:0	DRMOS_CS_TYPE	DrMOS current sense gain indicator for GUI. 000: CS gain is 8.5μA/A 001: CS gain is 9.7μA/A 010: CS gain is 10μA/A 011: CS gain is 5μA/A others: reserved
-----	---------------	--

MFR_VR_CONFIG3 (45h)

This register selects the main functions of the controller.

Command	MFR_VR_CONFIG3															
Format	Unsigned binary															
Bit	15	14	13	12	11	10	9	8	7	6	5	4	3	2	1	0
Access	r/w	r/w	r/w	r/w	r/w	r/w	r/w	r/w	r/w	r/w	r/w	r/w	r/w	r/w	r/w	r/w
Function	0											1				0

Bits	Bit Name	Description
15	RESERVED	Fixed to 0.
14	TEMP_FAULT_MODE	Mode selector of VTEMP_FAULT. 0: hiccup 1: latch
13	APS_ACTIVATE_MODE	APS activation mode after soft start when PSI is in mid-state. 1: activate APS when soft start has finished and PWM-VID signal starts switching (exiting Hi-Z state for the first time) 0: activate APS when soft start finishes, regardless of PWM-VID signal
12	PHASE_CNT_SET_MODE	Phase-count setting mode. 0: phase count set by bit[3:0] of MFR_VR_CONFIG1 (E1h) 1: phase count set by external CSx pin. CSx pins of unused phases should be shorted to GND in this mode. The controller only detects CSx pins during the first POR. Short the CS of certain phases to GND to block all higher-number phases.
11	PARAM_VOUT_MIN_MSB	Highest bit of parameter PARAM_VOUT_MIN. Parameter PARAM_VOUT_MIN_16LSB is described in register MFR_PARAM_VOUT_MIN (B4h).
10	MFR_CB_SS_EN	Enable bit for not holding the CB loop during soft start. 0: disable 1: enable
9	CB_LARGE_PI_EN	Enable bit for variable parameter control of CB loop. 0: disable. The PI parameter of the CB loop is always at a constant value. 1: enable. When the voltage error between CSx and CS1 is more than 50mV, a large PI parameter is adopted in the CB loop to make the regulation process faster. The large PI parameter is decided by bit[8:6] of MFR_VR_CONFIG3 (45h).
8:6	MFR_CB_LARGE_PI	Large PI parameter of the CB loop for variable parameter control. Internal PI parameter = MFR_CB_LARGE_PI * 32 + 31

5	PWMVID_3_LEVEL_EN	<p>Enable bit for 3-level VID control by the PWMVID pin in PMBus mode.</p> <p>0: disable 1: enable</p> <p>The relationship between the PWMVID pin state and VID is shown in the table below.</p> <table border="1"> <thead> <tr> <th>PWMVID</th> <th colspan="2">VID</th> </tr> </thead> <tbody> <tr> <td>High</td> <td>VOUT_MAX</td> <td>Register 24h</td> </tr> <tr> <td>Hi-Z</td> <td>VOUT_COMMAND / Vboot</td> <td>Register 21h / Determined by BOOT pin</td> </tr> <tr> <td>Low</td> <td>VOUT_MIN</td> <td>Register 1Fh</td> </tr> </tbody> </table>	PWMVID	VID		High	VOUT_MAX	Register 24h	Hi-Z	VOUT_COMMAND / Vboot	Register 21h / Determined by BOOT pin	Low	VOUT_MIN	Register 1Fh
PWMVID	VID													
High	VOUT_MAX	Register 24h												
Hi-Z	VOUT_COMMAND / Vboot	Register 21h / Determined by BOOT pin												
Low	VOUT_MIN	Register 1Fh												
4	TON_CLAMP_EN	<p>Enable bit for clamping the PWM on time to avoid a negative overflow.</p> <p>0: disable. PWM on-time range must be designed within 90ns to 1120ns. If the on time is less than 90ns, it risks a negative overflow. 1: enable. PWM on time can be clamped to MIN_ON_TIME(3Fh bit[6:4]). The on time design range is from MIN_ON_TIME to 1120ns.</p>												
3	VTEMP_OFFSET_SIGNED	<p>Sign bit of parameter VTEMP_OFFSET.</p> <p>The definition of the parameter VTEMP_OFFSET is described in register MFR_TEMP_GAIN_OFFSET (C1h).</p>												
2	PMBUS_VBOOT_SEL	<p>The V_{BOOT} control mode selection in PMBus mode.</p> <p>0: V_{BOOT} is determined by the value of VOUT_COMMAND (21h) 1: V_{BOOT} is determined by the voltage of TSNS/BOOT. After the soft start, the real-time VID can be updated by register VOUT_COMMAND (21h).</p>												
1:0	PIN_VBOOT_TABLE_SEL	<p>Pin-strap V_{BOOT} table selector.</p> <p>00: V_{BOOT} table is 0.1V/step, up to 1.5V 01: V_{BOOT} table is 0.05V/step, up to 1.55V 10: V_{BOOT} table is 0.2V/step, up to 3.0V 11: V_{BOOT} table is 0.1V/step, up to 3.1V</p> <p>Refer to Table 1a and Table 1b for detail.</p>												

CONFIG_ID (46h)

This register is the identification code for different applications.

Command	CONFIG_ID															
Format	Unsigned binary															
Bit	15	14	13	12	11	10	9	8	7	6	5	4	3	2	1	0
Access	r/w	r/w	r/w	r/w	r/w	r/w	r/w	r/w	r/w	r/w	r/w	r/w	r/w	r/w	r/w	r/w
Function																

Bits	Bit Name	Description
15:0	CONFIG_ID	Identification code for different applications. This is part of MPS product part numbers.

CONFIG_REV_MPS (47h)

This register saves the revision number to indicate different configurations.

Command	CONFIG_REV_MPS															
Format	Unsigned binary															
Bit	15	14	13	12	11	10	9	8	7	6	5	4	3	2	1	0
Access	r/w	r/w	r/w	r/w	r/w	r/w	r/w	r/w	r/w	r/w	r/w	r/w	r/w	r/w	r/w	r/w
Function	APPLICATION_REV				SILICON_REV				FIRMWARE_REV							

Bits	Bit Name	Description
15:12	APPLICATION_REV	Application version. "E" is for engineering version, "0" is for production version.
11:8	SILICON_REV	Silicon version. "0" indicates R0, "1" indicates R1, and so on.
7:0	FIRMWARE_REV	Revision number indicates different firmware configurations.

IOUT_OC_WARN_LIMIT (4Ah)

This register sets the output current OC warning threshold.

Command	IOUT_OC_WARN_LIMIT																		
Format	Unsigned binary																		
Bit	15	14	13	12	11	10	9	8	7	6	5	4	3	2	1	0			
Access	r/w	r/w	r/w	r/w	r/w	r/w	r/w	r/w	r/w	r/w	r/w	r/w	r/w	r/w	r/w	r/w			
Function	x	x	x	x	x	x	IOUT_OC_WARN_LIMIT												

Bits	Bit Name	Description
15:10	RESERVED	Unused. X indicates that writes are ignored and reads are always 0.
9:0	IOUT_OC_WARN_LIMIT	Output current OC warning threshold. If the sensed output current is greater than this threshold, bit[5] of STATUS_IOUT (7Bh) is set. 1A/LSB (TOTAL_CURRENT_RESOLUTION = 0) 2A/LSB (TOTAL_CURRENT_RESOLUTION = 1)

MFR_CS_OFFSET1 (4Ch)

This register sets the phase-current offset for the current balance loop.

Command	MFR_CS_OFFSET1																
Format	Signed binary																
Bit	15	14	13	12	11	10	9	8	7	6	5	4	3	2	1	0	
Access	r/w	r/w	r/w	r/w	r/w	r/w	r/w	r/w	r/w	r/w	r/w	r/w	r/w	r/w	r/w	r/w	
Function	x	CS_OS_PHASE4				CS_OS_PHASE3				CS_OS_PHASE2							

Bits	Bit Name	Description
15	RESERVED	Unused. X indicates that writes are ignored and reads are always 0.
14:10	CS_OS_PHASE4	Phase 4 current offset. Two's complement binary format. Bit[14] is the sign bit.
9:5	CS_OS_PHASE3	Phase 3 current offset. Two's complement binary format. Bit[9] is the sign bit.
4:0	CS_OS_PHASE2	Phase 2 current offset. Two's complement binary format. Bit[4] is the sign bit.

Calculate the phase-current offset with Equation (15):

$$CS_OS_PHASEn = 512 \times I_{OFFSET} \times K_{CS} \times R_{CS} / 1600 \quad (15)$$

Where R_{CS} is the phase current sense resistor (in kΩ), and K_{CS} is the current sense gain of the DrMOS (in μA/A).

MFR_CS_OFFSET2 (4Dh)

This register sets the phase-current offset for the current balance loop.

Command	MFR_CS_OFFSET2															
Format	Signed binary															
Bit	15	14	13	12	11	10	9	8	7	6	5	4	3	2	1	0
Access	r/w	r/w	r/w	r/w	r/w	r/w	r/w	r/w	r/w	r/w	r/w	r/w	r/w	r/w	r/w	r/w
Function	x			x					x					x		

Bits	Bit Name	Description
15	RESERVED	Unused. X indicates that writes are ignored and reads are always 0.
14:10	RESERVED	Unused. X indicates that writes are ignored and reads are always 0.
9:5	RESERVED	Unused. X indicates that writes are ignored and reads are always 0.
4:0	RESERVED	Unused. X indicates that writes are ignored and reads are always 0.

Calculate the phase-current offset with Equation (16):

$$CS_OS_PHASEn = 512 \times I_{OFFSET} \times K_{CS} \times R_{CS} / 1600 \quad (16)$$

Where R_{CS} is the phase current sense resistor (in k Ω), and K_{CS} is the current sense gain of the DrMOS (in $\mu A/A$).

MFR_CS_OFFSET3 (4Eh)

This register sets the phase-current offset for the current balance loop.

Command	MFR_CS_OFFSET3															
Format	Signed binary															
Bit	15	14	13	12	11	10	9	8	7	6	5	4	3	2	1	0
Access	r/w	r/w	r/w	r/w	r/w	r/w	r/w	r/w	r/w	r/w	r/w	r/w	r/w	r/w	r/w	r/w
Function	x			x					x					x		

Bits	Bit Name	Description
15	RESERVED	Unused. X indicates that writes are ignored and reads are always 0.
14:10	RESERVED	Unused. X indicates that writes are ignored and reads are always 0.
9:5	RESERVED	Unused. X indicates that writes are ignored and reads are always 0.
4:0	RESERVED	Unused. X indicates that writes are ignored and reads are always 0.

Calculate the phase-current offset with Equation (17):

$$CS_OS_PHASEn = 512 \times I_{OFFSET} \times K_{CS} \times R_{CS} / 1600 \quad (17)$$

Where R_{CS} is the phase current sense resistor (in k Ω), and K_{CS} is the current sense gain of the DrMOS (in $\mu A/A$).

OT_WARN_LIMIT (51h)

This register sets the over-temperature warning threshold via VTEMP.

Command	OT_WARN_LIMIT															
Format	Unsigned binary															
Bit	15	14	13	12	11	10	9	8	7	6	5	4	3	2	1	0
Access	r/w	r/w	r/w	r/w	r/w	r/w	r/w	r/w	r/w	r/w	r/w	r/w	r/w	r/w	r/w	r/w
Function	x	x	x	x	x	x	x	x								

Bits	Bit Name	Description
15:8	RESERVED	Unused. X indicates writes are ignored and reads are always 0.
7:0	OT_WARN_LIMIT	Over-temperature warning threshold. If the sensed temperature via VTEMP is higher than this value, bit[6] of STATUS_TEMPERATURE (7Dh) is set. 1°C/LSB.

VIN_OV_FAULT_LIMIT (55h)

This register sets the input OVP threshold.

Command	VIN_OV_FAULT_LIMIT															
Format	Linear, two's complement binary															
Bit	15	14	13	12	11	10	9	8	7	6	5	4	3	2	1	0
Access	r/w	r/w	r/w	r/w	r/w	r/w	r/w	r/w	r/w	r/w	r/w	r/w	r/w	r/w	r/w	r/w
Function	Exponent					x			Mantissa							

Bits	Bit Name	Description
15:11	Exponent	This value is in two's complement binary format (fixed at 11101). Exponent = -3
10:8	RESERVED	Unused. X indicates that writes are ignored and always read as 0.
7:0	Mantissa	$VIN_OV_FAULT_LIMIT = Mantissa \times 2^{exponent} = Mantissa \times 0.125$ If the sensed input voltage is greater than this threshold, the input OVP is triggered, and the VR shuts down immediately.

VIN_UV_WARN_LIMIT (58h)

This register sets the input under-voltage warning threshold.

Command	VIN_UV_WARN_LIMIT															
Format	Linear, two's complement binary															
Bit	15	14	13	12	11	10	9	8	7	6	5	4	3	2	1	0
Access	r/w	r/w	r/w	r/w	r/w	r/w	r/w	r/w	r/w	r/w	r/w	r/w	r/w	r/w	r/w	r/w
Function	Exponent					x			Mantissa							

Bits	Bit Name	Description
15:11	Exponent	This value is in two's complement binary format (fixed at 11101). Exponent = -3
10:8	RESERVED	Unused. X indicates that writes are ignored and always read as 0.
7:0	Mantissa	$VIN_UV_WARN_LIMIT = Mantissa \times 2^{exponent} = Mantissa \times 0.125$ If the sensed input voltage is lower than this threshold, bit[5] of the status register STATUS_INPUT (7Ch) is set.

MFR_DELAY_SET (5Dh)

The register sets the delay time of the power good signal and internal V_{OUT} settle signal.

Command	MFR_DELAY_SET															
Format	Unsigned binary															
Bit	15	14	13	12	11	10	9	8	7	6	5	4	3	2	1	0
Access	r/w	r/w	r/w	r/w	r/w	r/w	r/w	r/w	r/w	r/w	r/w	r/w	r/w	r/w	r/w	r/w
Function	x	x	x	SETTLE_DELAY				PG_DELAY								

Bits	Bit Name	Description
15:13	RESERVED	Unused. X indicates that writes are ignored and reads are always 0.
12:9	SETTLE_DELAY	Delay time from when the output voltage reference reaches the target level to when the internal V_{OUT} settle signal becomes high. 100 μ s/LSB. When V_{REF} is ramping (soft start or DVID), the settle signal is low. When V_{REF} is settled, the settle signal is high. The DC loop or auto-power mode operate only when the settle signal is high.
8:0	PG_DELAY	Delay time for asserting the power good signal. 1 μ s/LSB.

POWER_GOOD_ON (5Eh)

This register sets the output voltage threshold at which the power good signal is asserted.

Command	POWER_GOOD_ON															
Format	VID															
Bit	15	14	13	12	11	10	9	8	7	6	5	4	3	2	1	0
Access	r/w	r/w	r/w	r/w	r/w	r/w	r/w	r/w	r/w	r/w	r/w	r/w	r/w	r/w	r/w	r/w
Function	x	x	x	x	x	x	x	POWER_GOOD_ON								

Bits	Bit Name	Description
15:9	RESERVED	Unused. X indicates that writes are ignored and reads are always 0.
8:0	POWER_GOOD_ON	Output voltage threshold at which the power good signal is asserted. 6.25mV/LSB.

POWER_GOOD_OFF (5Fh)

This register sets the output voltage threshold at which the power good signal is deasserted.

Command	POWER_GOOD_OFF															
Format	VID															
Bit	15	14	13	12	11	10	9	8	7	6	5	4	3	2	1	0
Access	r/w	r/w	r/w	r/w	r/w	r/w	r/w	r/w	r/w	r/w	r/w	r/w	r/w	r/w	r/w	r/w
Function	x	x	x	x	x	x	x	POWER_GOOD_OFF								

Bits	Bit Name	Description
15:9	RESERVED	Unused. X indicates that writes are ignored and reads are always 0.
8:0	POWER_GOOD_OFF	Output voltage threshold at which the power good signal is deasserted. 6.25mV/LSB

TON_DELAY (60h)

This register sets the time from when the controller receives the EN on signal to when V_{REF} starts to boot up.

Command	TON_DELAY															
Format	Unsigned binary															
Bit	15	14	13	12	11	10	9	8	7	6	5	4	3	2	1	0
Access	r/w	r/w	r/w	r/w	r/w	r/w	r/w	r/w	r/w	r/w	r/w	r/w	r/w	r/w	r/w	r/w
Function	EN_ON_DELAY															

Bits	Bit Name	Description
15:0	EN_ON_DELAY	Delay time from EN on to V_{REF} boot-up. 50 μ s/LSB (DLY_CLK_SEL = 1) 20 μ s/LSB (DLY_CLK_SEL = 0)

TOFF_DELAY (64h)

This register sets the time from when the controller receives the EN off signal to when V_{REF} starts to soft-shut down.

Command	TOFF_DELAY															
Format	Unsigned binary															
Bit	15	14	13	12	11	10	9	8	7	6	5	4	3	2	1	0
Access	r/w	r/w	r/w	r/w	r/w	r/w	r/w	r/w	r/w	r/w	r/w	r/w	r/w	r/w	r/w	r/w
Function	EN_OFF_DELAY															

Bits	Bit Name	Description
15:0	EN_OFF_DELAY	Delay time from EN off to V_{REF} soft-shutdown. 50 μ s/LSB (DLY_CLK_SEL = 1) 20 μ s/LSB (DLY_CLK_SEL = 0)

POUT_OP_WARN_LIMIT (6Ah)

This register sets the output over-power warning threshold.

Command	POUT_OP_WARN_LIMIT																	
Format	Unsigned binary																	
Bit	15	14	13	12	11	10	9	8	7	6	5	4	3	2	1	0		
Access	r/w	r/w	r/w	r/w	r/w	r/w	r/w	r/w	r/w	r/w	r/w	r/w	r/w	r/w	r/w	r/w		
Function	x	x	x	x	x	x	POUT_OP_WARN_LIMIT											

Bits	Bit Name	Description
15:10	RESERVED	Unused. X indicates that writes are ignored and reads are always 0.
9:0	POUT_OP_WARN_LIMIT	Output over-power warning threshold. If the sensed output power is higher than this threshold, bit[0] of STATUS_IOUT (7Bh) is set. 1W/LSB (TOTAL_CURRENT_RESOLUTION = 0) 2W/LSB (TOTAL_CURRENT_RESOLUTION = 1)

START_CATCH_AVE (6Bh)

This command is used for READ_IOUT, READ_PIN, READ_POUT, and READ_EFFICIENCY when these registers are in latch mode. Send the START_CATCH_AVE command to trigger the averaging process within a certain average window. At the end of the average window, the results are latched.

The averaging mode and average window are determined by MFR_REPORT_CTRL (ADh).

This command is write only. There is no data byte for this command.

READ_CS1_2 (73h)

This register is phase-current ADC value of phase 1 and phase 2. An internal low-pass filter is used before ADC.

Command	READ_CS1_2															
Format	Unsigned binary															
Bit	15	14	13	12	11	10	9	8	7	6	5	4	3	2	1	0
Access	r	r	r	r	r	r	r	r	r	r	r	r	r	r	r	r
Function	READ_CS2								READ_CS1							

Bits	Bit Name	Description
15:8	READ_CS2	Phase 2 current ADC sense value.
7:0	READ_CS1	Phase 1 current ADC sense value.

Calculate the per-phase current sense with Equation (18):

$$CS_n = 256 \times (I_{CS} \times K_{CS} \times R_{CS} / 1000 + 1.23) / 3.2 \quad (18)$$

Where R_{CS} is the phase current sense resistor (in k Ω), and K_{CS} is the current sense gain of the DrMOS (in $\mu A/A$).

If PHASE_CURRENT_RESOLUTION = 1 in register 44h, the CS report should be doubled.

READ_CS3_4 (74h)

This register is the phase-current ADC value of phase 3 and phase 4. An internal low-pass filter is used before ADC.

Command	READ_CS3_4															
Format	Unsigned binary															
Bit	15	14	13	12	11	10	9	8	7	6	5	4	3	2	1	0
Access	r	r	r	r	r	r	r	r	r	r	r	r	r	r	r	r
Function	READ_CS4								READ_CS3							

Bits	Bit Name	Description
15:8	READ_CS4	Phase 4 current ADC sense value.
7:0	READ_CS3	Phase 3 current ADC sense value.

Calculate the per-phase current sense with Equation (19):

$$CS_n = 256 \times (I_{CS} \times K_{CS} \times R_{CS} / 1000 + 1.23) / 3.2 \quad (19)$$

Where R_{CS} is the phase current sense resistor (in k Ω), and K_{CS} is the current sense gain of the DrMOS (in $\mu A/A$).

If PHASE_CURRENT_RESOLUTION = 1 in register 44h, the CS report should be doubled.

READ_CS5_6 (75h)

This register is the phase-current ADC value of phase 5 and phase 6. An internal low-pass filter is used before ADC.

Command	READ_CS5_6															
Format	Unsigned binary															
Bit	15	14	13	12	11	10	9	8	7	6	5	4	3	2	1	0
Access	r	r	r	r	r	r	r	r	r	r	r	r	r	r	r	r
Function	x								x							

Bits	Bit Name	Description
15:8	RESERVED	Unused. X indicates that writes are ignored and reads are always 0.
7:0	RESERVED	Unused. X indicates that writes are ignored and reads are always 0.

Calculate the per-phase current sense with Equation (20):

$$CS_n = 256 \times (I_{CS} \times K_{CS} \times R_{CS} / 1000 + 1.23) / 3.2 \quad (20)$$

Where R_{CS} is the phase current sense resistor (in k Ω), and K_{CS} is the current sense gain of the DrMOS (in $\mu A/A$).

If PHASE_CURRENT_RESOLUTION = 1 in register 44h, the CS report should be doubled.

READ_CS7_8 (76h)

This register is the phase-current ADC value of phase 7 and phase 8. An internal low-pass filter is used before ADC.

Command	READ_CS7_8															
Format	Unsigned binary															
Bit	15	14	13	12	11	10	9	8	7	6	5	4	3	2	1	0
Access	r	r	r	r	r	r	r	r	r	r	r	r	r	r	r	r
Function	x								x							

Bits	Bit Name	Description
15:8	RESERVED	Unused. X indicates that writes are ignored and reads are always 0.
7:0	RESERVED	Unused. X indicates that writes are ignored and reads are always 0.

Calculate the per-phase current sense with Equation (21):

$$CS_n = 256 \times (I_{CS} \times K_{CS} \times R_{CS} / 1000 + 1.23) / 3.2 \quad (21)$$

Where R_{CS} is the phase current sense resistor (in k Ω), and K_{CS} is the current sense gain of the DrMOS (in $\mu A/A$).

If PHASE_CURRENT_RESOLUTION = 1 in register 44h, the CS report should be doubled.

READ_CS9_10 (77h)

This register is the phase-current ADC value of phase 9 and phase 10. An internal low-pass filter is used before ADC.

Command	READ_CS9_10															
Format	Unsigned binary															
Bit	15	14	13	12	11	10	9	8	7	6	5	4	3	2	1	0
Access	r	r	r	r	r	r	r	r	r	r	r	r	r	r	r	r
Function	x								x							

Bits	Bit Name	Description
15:8	RESERVED	Unused. X indicates that writes are ignored and reads are always 0.
7:0	RESERVED	Unused. X indicates that writes are ignored and reads are always 0.

Calculate the per-phase current sense with Equation (22):

$$CS_n = 256 \times (I_{CS} \times K_{CS} \times R_{CS} / 1000 + 1.23) / 3.2 \quad (22)$$

Where R_{CS} is the phase current sense resistor (in k Ω), and K_{CS} is the current sense gain of the DrMOS (in $\mu A/A$).

If PHASE_CURRENT_RESOLUTION = 1 in register 44h, the CS report should be doubled.

STATUS_BYTE (78h)

This register returns one byte of information for critical faults.

Command	STATUS_BYTE							
Format	Unsigned binary							
Bit	7	6	5	4	3	2	1	0
Access	r/w	r/w	r/w	r/w	r/w	r/w	r/w	r/w
Function	x							x

Bits	Bit Name	Description
7	RESERVED	Unused. X indicates that writes are ignored and reads are always 0.
6	OFF	This bit is asserted if the unit is not providing power to the output. This bit is in live mode.
5	VOUT_OV_FAULT	Once output OVP occurs, this bit is set. This bit is in latch mode. The CLEAR_FAULTS command can reset this bit.
4	IOUT_OC_FAULT	Once output OCP occurs, this bit is set. This bit is in latch mode. The CLEAR_FAULTS command can reset this bit.
3	VIN_UV_FAULT	Once input UVP occurs, this bit is set. This bit is in latch mode. The CLEAR_FAULTS command can reset this bit.
2	TEMPERATURE	Once OTP or a warning occur, this bit is set. This bit is in latch mode. The CLEAR_FAULTS command can reset this bit.
1	CML	Once a communications, memory, or logic fault occurs, this bit is set. This bit is in latch mode. The CLEAR_FAULTS command can reset this bit.
0	RESERVED	Unused. X indicates that writes are ignored and reads are always 0.

STATUS_WORD (79h)

This register returns two bytes of information for fault statuses. Based on this information, the host can get more information by reading the appropriate status registers. The low byte of STATUS_WORD is the same as the STATUS_BYTE register.

Command	STATUS_WORD															
Format	Unsigned binary															
Bit	15	14	13	12	11	10	9	8	7	6	5	4	3	2	1	0
Access	r	r	r	r	r	r	r	r	r	r	r	r	r	r	r	r
Function						x	x		x							x

Bits	Bit Name	Description
15	VOUT	Once output OVP, UVP, or a warning occurs, this bit is set. This bit is in latch mode. The CLEAR_FAULTS command can reset this bit.
14	IOUT/POUT	Once output OCP, over-power protection (OPP), or a warning occurs, this bit is set. This bit is in latch mode. The CLEAR_FAULTS command can reset this bit.
13	INPUT	Once any protection or warning of the input voltage, input current, or input power occurs, this bit is set. This bit is in latch mode. The CLEAR_FAULTS command can reset this bit.
12	READ_DATA_RDY	When READ_PIN, READ_POOUT, or READ_EFFECIENCY uses average window mode and once the average window calculation is done, the data is ready in the resistor, and this bit is set. Sending the command START_CATCH_AVE triggers a new averaging process and resets this bit.
11	POWER_GOOD	When V _{OUT} rises higher than the POWER_GOOD_ON level during the soft-start process and the delay time is reached, this bit is asserted. This bit is in live mode.
10:9	RESERVED	Unused. X indicates that writes are ignored and reads are always 0.
8	WATCH_DOG_OVF	The monitor value calculation has a watchdog timer. If the timer expires, the monitor value calculation state machine and the timer are reset. Meanwhile, this bit is set. This bit is in latch mode. The CLEAR_FAULTS command can reset this bit.
7	RESERVED	Unused. X indicates that writes are ignored and reads are always 0.
6	OFF	This bit is asserted if the unit is not providing power to the output. This bit is in live mode.
5	VOUT_OV_FAULT	Once output OVP occurs, this bit is set. This bit is in latch mode. The CLEAR_FAULTS command can reset this bit.
4	IOUT_OC_FAULT	Once output OCP occurs, this bit is set. This bit is in latch mode. The CLEAR_FAULTS command can reset this bit.
3	VIN_UV_FAULT	Once input UVP occurs, this bit is set. This bit is in latch mode. The CLEAR_FAULTS command can reset this bit.
2	TEMPERATURE	Once OTP or a warning occurs, this bit is set. This bit is in latch mode. The CLEAR_FAULTS command can reset this bit.
1	CML	Once a communication, memory, or logic fault occurs, this bit is set. This bit is in latch mode. The CLEAR_FAULTS command can reset this bit.
0	RESERVED	Unused. X indicates that writes are ignored and reads are always 0.

STATUS_VOUT (7Ah)

This register records the fault and warning status of the output voltage.

Command	STATUS_VOUT							
Format	Unsigned binary							
Bit	7	6	5	4	3	2	1	0
Access	r	r	r	r	r	r	r	r
Function		x				x		

Bits	Bit Name	Description
7	VOUT_OV_FAULT	Once output OVP occurs, this bit is set. This bit is in latch mode. The CLEAR_FAULTS command can reset this bit.
6	RESERVED	Unused. X indicates that writes are ignored and reads are always 0.
5	VOUT_UV_WARNING	Once an output over-voltage warning occurs, this bit is set. This bit is in latch mode. The CLEAR_FAULTS command can reset this bit.
4	VOUT_UV_FAULT	Once output UVP occurs, this bit is set. This bit is in latch mode. The CLEAR_FAULTS command can reset this bit.
3	VOUT_MAX_MIN_WARNING	Once the value of the PMBus command VOUT_COMMAND, VOUT_MARGIN_HIGH, or VOUT_MARGIN_LOW exceeds VOUT_MAX or VOUT_MIN, this bit is set. This bit is in latch mode. The CLEAR_FAULTS command can reset this bit.
2	RESERVED	Unused. X indicates that writes are ignored and reads are always 0.
1	LINE_FLOAT	During the EEPROM restore process after the chip powers on, the controller can check if the output voltage remote sense pin is floating with this function enabled. Once the controller detects that VOSEN is floating, it enters shutdown mode, and this bit is set.
0	VDIFF_FAULT	During the soft-start process, once the MP2884A detects that VOSEN is greater than VDIFF by 0.5V, the VR is shut down immediately, and this bit is set.

STATUS_IOUT (7Bh)

This register records the fault and warning status of the output current.

Command	STATUS_IOUT							
Format	Unsigned binary							
Bit	7	6	5	4	3	2	1	0
Access	r	r	r	r	r	r	r	r
Function				x	x	x	x	

Bits	Bit Name	Description
7	IOUT_OC_FAULT	Once output OCP occurs, this bit is set. This bit is in latch mode. The CLEAR_FAULTS command can reset this bit.
6	OC_UV_FAULT	If both output OCP and OVP occur, this bit is set. This bit is in latch mode. The CLEAR_FAULTS command can reset this bit.
5	IOUT_OC_WARNING	Once an output OC warning occurs, this bit is set. This bit is in latch mode. The CLEAR_FAULTS command can reset this bit.
4:1	RESERVED	Unused. X indicates that writes are ignored and reads are always 0.
0	POUT_OP_WARNING	Once output over-power protection (OPP) occurs, this bit is set. This bit is in latch mode. The CLEAR_FAULTS command can reset this bit.

STATUS_INPUT (7Ch)

This register records the fault and warning status of the input voltage, input current, and input power.

Command	STATUS_INPUT							
Format	Unsigned binary							
Bit	7	6	5	4	3	2	1	0
Access	r	r	r	r	r	r	r	r
Function		x				x	x	x

Bits	Bit Name	Description
7	VIN_OV_FAULT	Once the sensed input voltage is greater than VIN_OV_FAULT_LIMIT (55h), this bit is set. This bit is in latch mode. The CLEAR_FAULTS command can reset this bit.
6	RESERVED	Unused. X indicates that writes are ignored and reads are always 0.
5	VIN_UV_WARNING	Once the sensed input voltage is less than VIN_UV_WARN_LIMIT (58h), this bit is set. This bit is in latch mode. The CLEAR_FAULTS command can reset this bit.
4	VIN_UVLO_LATCH	Once the sensed input voltage is less than VIN_OFF, the VR turns off the power, and this bit is set. This bit is in latch mode. The CLEAR_FAULTS command can reset this bit.
3	VIN_UVLO_LIVE	Once the sensed input voltage is less than VIN_OFF, this bit is set. Once the sensed input voltage is greater than VIN_ON, this bit is reset. This bit is in live mode.
2:0	RESERVED	Unused. X indicates that writes are ignored and reads are always 0.

STATUS_TEMPERATURE (7Dh)

This register records the fault and warning status of temperature.

Command	STATUS_TEMPERATURE							
Format	Unsigned binary							
Bit	7	6	5	4	3	2	1	0
Access	r	r	r	r	r	r	r	r
Function			x	x			x	x

Bits	Bit Name	Description
7	TEMP_OT_FAULT	Once the sensed temperature via VTEMP is greater than VTEMP_OTP_LIMIT, this bit is set. This bit is in latch mode. The CLEAR_FAULTS command can reset this bit.
6	TEMP_OT_WARNING	Once the sensed temperature via VTEMP is greater than VTEMP_OT_WARN_LIMIT, this bit is set. This bit is in latch mode. The CLEAR_FAULTS command can reset this bit.
5:4	RESERVED	Unused. X indicates that writes are ignored and reads are always 0.
3	TSNS_OT_FAULT	Once the sensed temperature via TSNS is greater than the TSNS_OTP_LIMIT, this bit is set. This bit is in latch mode. The CLEAR_FAULTS command can reset this bit.
2	TSNS_OT_WARNING	Once the sensed temperature via TSNS is greater than TSNS_OT_WARN_LIMIT, this bit is set. This bit is in latch mode. The CLEAR_FAULTS command can reset this bit.
1:0	RESERVED	Unused. X indicates that writes are ignored and reads are always 0.

STATUS_CML (7Eh)

This register records the fault status of PMBus communication and EEPROM operation.

Command	STATUS_CML							
Format	Unsigned binary							
Bit	7	6	5	4	3	2	1	0
Access	r	r	r	r	r	r	r	r
Function								

Bits	Bit Name	Description
7	INVALID_CMD	This bit is set when it receives an unsupported command code. This bit is in latch mode. The CLEAR_FAULTS command can reset this bit.
6	INVALID_DATA	This bit is set when it receives invalid or unsupported data (host sends too many bytes). This bit is in latch mode. The CLEAR_FAULTS command can reset this bit.
5	PEC_FAULT	The PMBus interface supports the use of a packet error checking (PEC) byte that is defined in the SMBus standard. The PEC byte is transmitted by the MP2884A during a read transaction or sent by the bus host to the MP2884A during a write transaction. If the PEC byte sent during a write transaction is incorrect, the command is not executed, and this bit is set. This bit is in latch mode. The CLEAR_FAULTS command can reset this bit.
4	CRC_FAULT	During the process of storing memory data to the EEPROM, the MP2884A calculates the CRC for each bit and saves the final CRC code to the EEPROM. During the process of restoring the EEPROM data to the memory, the MP2884A calculates the CRC code with each bit. The MP2884A checks the CRC results when the restore process is done. If the CRC result is incorrect, the VR does not start up, and this bit is set. This bit is in latch mode. The CLEAR_FAULTS command can reset this bit.
3	MEMORY_PWD_MATCH	There is write protection for the PMBus registers. If enabled, the PMBus registers can be read only and are not writeable. The register MFR_USER_PWD (04h) stores the password. Once the key is matched with MFR_USER_PWD, this bit is set. Otherwise, this bit is reset. This bit is in live mode.
2	FAULT_STORE_FLAG	This device automatically records fault statuses to the EEPROM. Once the power shuts down for any protection, the fault status record process is triggered, and this bit is set. This bit is in latch mode. The CLEAR_FAULTS command can reset this bit.
1	CML_OTHER_FAULTS	If any of the below faults occur during PMBus communication, this bit is set. 1) Sending too few bits 2) Reading too few bits 3) Host sends or reads too few bytes 4) Reading too many bytes This bit is in latch mode. The CLEAR_FAULTS command can reset this bit.
0	EEPROM_FAULTS	When restoring data from the EEPROM to the memory, this bit first checks the signature register in address 00h of the EEPROM. If the signature is not matched, this process is ceased immediately, and this bit is set. This bit is in latch mode. The CLEAR_FAULTS command can reset this bit.

READ_VIN (88h)

This register records the sensed input voltage.

Command	READ_VIN															
Format	Unsigned binary															
Bit	15	14	13	12	11	10	9	8	7	6	5	4	3	2	1	0
Access	r	r	r	r	r	r	r	r	r	r	r	r	r	r	r	r
Function	x	x	x	x	x	x	READ_VIN									

Bits	Bit Name	Description
15:10	RESERVED	Unused. Fixed to 111011.
9:0	READ_VIN	0.03125V/LSB.

READ_VOUT (8Bh)

This register records the sensed output voltage.

Command	READ_VOUT															
Format	Unsigned binary															
Bit	15	14	13	12	11	10	9	8	7	6	5	4	3	2	1	0
Access	r	r	r	r	r	r	r	r	r	r	r	r	r	r	r	r
Function	x	x	x	x	READ_VOUT											

Bits	Bit Name	Description
15:12	RESERVED	Unused. X indicates that writes are ignored and reads are always 0.
11:0	READ_VOUT	1mV/LSB.

READ_IOUT (8Ch)

This register records the sensed output current.

Command	READ_IOUT															
Format	Unsigned binary															
Bit	15	14	13	12	11	10	9	8	7	6	5	4	3	2	1	0
Access	r	r	r	r	r	r	r	r	r	r	r	r	r	r	r	r
Function	x	x	x	x	READ_IOUT											

Bits	Bit Name	Description
15:12	RESERVED	Unused. Fixed to 1110.
11:0	READ_IOUT	0.25A/LSB (TOTAL_CURRENT_RESOLUTION = 0) 0.5A/LSB (TOTAL_CURRENT_RESOLUTION = 1)

READ_TEMPERATURE (8Dh)

This register records the sensed temperature.

Command	READ_TEMPERATURE															
Format	Unsigned binary															
Bit	15	14	13	12	11	10	9	8	7	6	5	4	3	2	1	0
Access	r	r	r	r	r	r	r	r	r	r	r	r	r	r	r	r
Function	x	x	x	x	x	READ_TEMPERATURE										

Bits	Bit Name	Description
15:11	RESERVED	Unused. X indicates that writes are ignored and reads are always 0.
10:0	READ_TEMPERATURE	0.1°C/LSB.

READ_EFFECIENCY (95h)

This register records the calculated efficiency of the VR.

Command	READ_EFFECIENCY															
Format	Unsigned binary															
Bit	15	14	13	12	11	10	9	8	7	6	5	4	3	2	1	0
Access	r	r	r	r	r	r	r	r	r	r	r	r	r	r	r	r
Function	x	x	x	x	x	x	x	READ_EFFECIENCY								

Bits	Bit Name	Description
15:9	RESERVED	Unused. X indicates that writes are ignored and reads are always 0.
8:0	READ_EFFECIENCY	0.195%/LSB.

READ_POUT (96h)

This register records the sensed output power.

Command	READ_POUT															
Format	Unsigned binary															
Bit	15	14	13	12	11	10	9	8	7	6	5	4	3	2	1	0
Access	r	r	r	r	r	r	r	r	r	r	r	r	r	r	r	r
Function	x	x	x	x	x	READ_POUT										

Bits	Bit Name	Description
15:11	RESERVED	Unused. X indicates that writes are ignored and reads are always 0.
10:0	READ_POUT	0.5W/LSB (TOTAL_CURRENT_RESOLUTION = 0) 1W/LSB (TOTAL_CURRENT_RESOLUTION = 1)

READ_PIN (97h)

This register records the calculated input power.

Command	READ_PIN															
Format	Unsigned binary															
Bit	15	14	13	12	11	10	9	8	7	6	5	4	3	2	1	0
Access	r	r	r	r	r	r	r	r	r	r	r	r	r	r	r	r
Function	x	x	x	x	x	READ_PIN										

Bits	Bit Name	Description
15:11	RESERVED	Unused. X indicates that writes are ignored and reads are always 0.
10:0	READ_PIN	0.5W/LSB (TOTAL_CURRENT_RESOLUTION = 0) 1W/LSB (TOTAL_CURRENT_RESOLUTION = 1)

MFR_APS_FS_LIMIT1 (A3h)

This register sets the interval time threshold between the consecutive phases' PWM rising edges to detect a fast load increase. When APS is enabled and the system sheds phases, once the interval time is lower than this threshold, the VR exits phase shedding and runs with a full phase for a configurable amount of time.

Command	MFR_APS_FS_LIMIT1															
Format	Unsigned binary															
Bit	15	14	13	12	11	10	9	8	7	6	5	4	3	2	1	0
Access	r/w	r/w	r/w	r/w	r/w	r/w	r/w	r/w	r/w	r/w	r/w	r/w	r/w	r/w	r/w	r/w
Function																

Bits	Bit Name	Description
15:8	FS_LIMIT_4P	Threshold of the interval time between consecutive phases' PWM rising edges when the VR has shed to four phases. 5ns/LSB. Add PHASE_BLANK_TIME to the final threshold.
7:0	FS_LIMIT_3P	Threshold of the interval time between consecutive phases' PWM rising edges when the VR has shed to three phases. 5ns/LSB. Add PHASE_BLANK_TIME to the final threshold.

MFR_APS_FS_LIMIT2 (A4h)

This register sets the interval time threshold between the consecutive phases' PWM rising edges to detect a fast load increase. When APS is enabled and the system sheds phases, once the interval time is lower than this threshold, the system exits phase shedding and runs with a full phase for a configurable amount of time.

Command	MFR_APS_FS_LIMIT2															
Format	Unsigned binary															
Bit	15	14	13	12	11	10	9	8	7	6	5	4	3	2	1	0
Access	r/w	r/w	r/w	r/w	r/w	r/w	r/w	r/w	r/w	r/w	r/w	r/w	r/w	r/w	r/w	r/w
Function	x								x							

Bits	Bit Name	Description
15:8	RESERVED	Unused. X indicates that writes are ignored and reads are always 0.
7:0	RESERVED	Unused. X indicates that writes are ignored and reads are always 0.

MFR_APS_FS_LIMIT3 (A5h)

This register sets the interval time threshold between the consecutive phases' PWM rising edges to detect a fast load increase. When APS is enabled and the system sheds phases, once the interval time is lower than this threshold, the system exits phase shedding and runs with a full-phase for a configurable amount of time.

Command	MFR_APS_FS_LIMIT3															
Format	Unsigned binary															
Bit	15	14	13	12	11	10	9	8	7	6	5	4	3	2	1	0
Access	r/w	r/w	r/w	r/w	r/w	r/w	r/w	r/w	r/w	r/w	r/w	r/w	r/w	r/w	r/w	r/w
Function	x								x							

Bits	Bit Name	Description
15:8	RESERVED	Unused. X indicates that writes are ignored and reads are always 0.
7:0	RESERVED	Unused. X indicates that writes are ignored and reads are always 0.

MFR_APS_FS_LIMIT4 (A6h)

This register sets the interval time threshold between the consecutive phases' PWM rising edges to detect a fast load increase. When APS is enabled and the system sheds phases, once the interval time is lower than this threshold, the system exits phase shedding and runs with a full-phase for a configurable amount of time.

Command	MFR_APS_FS_LIMIT4															
Format	Unsigned binary															
Bit	15	14	13	12	11	10	9	8	7	6	5	4	3	2	1	0
Access	r/w	r/w	r/w	r/w	r/w	r/w	r/w	r/w	r/w	r/w	r/w	r/w	r/w	r/w	r/w	r/w
Function	x								x							

Bits	Bit Name	Description
15:8	RESERVED	Unused. X indicates that writes are ignored and reads are always 0.
7:0	RESERVED	Unused. X indicates that writes are ignored and reads are always 0.

MFR_APS_FS_CTRL1 (A7h)

This register sets the interval time threshold for phase 1's PWM to detect a fast load increase. When APS is enabled and the system sheds phases, once the controller detects that the PWM interval is lower than this threshold, the system exits phase shedding and runs with a full-phase for a configurable amount of time. This register also sets the enable bit for the exit-phase-shedding strategy via PWM frequency detection.

Command	MFR_APS_FS_CTRL1															
Format	Unsigned binary															
Bit	15	14	13	12	11	10	9	8	7	6	5	4	3	2	1	0
Access	r/w	r/w	r/w	r/w	r/w	r/w	r/w	r/w	r/w	r/w	r/w	r/w	r/w	r/w	r/w	r/w
Function	x	x	x													

Bits	Bit Name	Description
15:13	RESERVED	Unused. X indicates that writes are ignored and reads are always 0.
12	FS_EXIT_APS_EN1	Enable bit of exit-phase-shedding according to phase 1's PWM interval time. 0: disable 1: enable The controller detects phase 1's PWM interval time from the end of MIN_OFF_TIME.
11	FS_EXIT_APS_EN2	Enable bit of exit-phase-shedding according to the PWM interval time between consecutive phases. 0: disable 1: enable The controller detects the consecutive phases' PWM interval time from the end of PHASE_BLANK_TIME.

10:8	FS_EXIT_APS_CNT1	Continuous counting threshold for exit-phase-shedding according to phase 1's PWM interval time.
7:0	FS_LIMIT_1P	Threshold of phase 1's PWM interval time. 5ns/LSB. Add MIN_OFF_TIME to the final threshold.

MFR_APS_FS_CTRL2 (A8h)

This register sets the threshold of the interval time between the consecutive phases' PWM rising edges to detect a fast load increase. When APS is enabled and the system sheds phases, once the controller detects that the PWM interval is lower than this threshold, the system exits phase shedding and runs with a full phase for a configurable amount of time. This register also sets the full-phase running time from exiting phase shedding to returning to phase-shedding mode.

Command	MFR_APS_FS_CTRL2															
Format	Unsigned binary															
Bit	15	14	13	12	11	10	9	8	7	6	5	4	3	2	1	0
Access	r/w	r/w	r/w	r/w	r/w	r/w	r/w	r/w	r/w	r/w	r/w	r/w	r/w	r/w	r/w	r/w
Function	x															

Bits	Bit Name	Description
15	RESERVED	Unused. X indicates that writes are ignored and reads are always 0.
14:11	RETURN_APS_DELAY	Delay time for returning APS from exiting phase shedding due to the PWM interval time being shorter than the configured threshold. 20µs/LSB.
10:8	FS_EXIT_APS_CNT2	Continuous counting time threshold for exit-phase-shedding mode according to the PWM interval time between consecutive phases.
7:0	FS_LIMIT_2P	Threshold of the interval time between consecutive phases' PWM rising edges when the VR has shed to two phases. 5ns/LSB. Add PHASE_BLANK_TIME to the final threshold.

MFR_PHASE_SHED_CTRL (A9h)

This register sets the checking time for phase shedding by detecting the output current and set compensation to reduce voltage undershoot during phase dropping.

Command	MFR_PHASE_SHED_CTRL															
Format	Unsigned binary															
Bit	15	14	13	12	11	10	9	8	7	6	5	4	3	2	1	0
Access	r/w	r/w	r/w	r/w	r/w	r/w	r/w	r/w	r/w	r/w	r/w	r/w	r/w	r/w	r/w	r/w
Function	APS_DROP_CHECK_CNT								EXIT_VO_CMPN_STEP_TIME							

Bits	Bit Name	Description
15:9	APS_DROP_CHECK_CNT	Continuous counting-times threshold for phase shedding when the APS function is enabled. Once the output current enters the drop-phase window, an internal timer starts counting until it reaches this counting-times threshold. Then the VR drops phases. The timer resets if the output current exits the drop-phase window before it reaches the counting-times threshold.
8:4	EXIT_VO_CMPN_STEP_TIME	Interval time for reducing each 1.37mV step for V _{OUT} compensation when the phase-dropping process ends. 50ns/LSB.
3:0	DROP_PHASE_VO_CMPN	V _{OUT} undershoot compensation value for phase dropping. 1.37mV/LSB.

MFR_LOW_PHASE_CNT (AAh)

This register sets the phase number when PSI is low (low-phase mode).

Command	MFR_LOW_PHASE_CNT															
Format	Unsigned binary															
Bit	15	14	13	12	11	10	9	8	7	6	5	4	3	2	1	0
Access	r/w	r/w	r/w	r/w	r/w	r/w	r/w	r/w	r/w	r/w	r/w	r/w	r/w	r/w	r/w	r/w
Function	x	x	x	x	x	x	x	x								

Bits	Bit Name	Description
15:8	RESERVED	Unused. X indicates that writes are ignored and reads are always 0.
7:4	LOW_PHASE_CNT_WARM	Phase number in low-phase mode (PSI is low) for warm boot. First time power-on after POR is considered to be a cool boot.
3:0	LOW_PHASE_CNT_COLD	Phase number in low-phase mode (PSI is low) for cold boot. Boot-up process beside the first power-on after POR is considered to be a warm boot.

MFR_APS_CTRL (ABh)

This register configures the detailed performance related to APS.

Command	MFR_APS_CTRL															
Format	Unsigned binary															
Bit	15	14	13	12	11	10	9	8	7	6	5	4	3	2	1	0
Access	r/w	r/w	r/w	r/w	r/w	r/w	r/w	r/w	r/w	r/w	r/w	r/w	r/w	r/w	r/w	r/w
Function	RETURN_APS_DELAY										DROP_PHASE_INTERVAL					

Bits	Bit Name	Description
15:10	RETURN_APS_DELAY	Delay time for returning APS from exiting phase shedding due to phase 1 triggering the valley current limit when the system runs at 1-phase or V_{FB} drops below $V_{REF} - 25mV$. 20 μs /LSB.
9	N25MV_EXIT_EN	Enable bit for exiting phase shedding (jumping to full-phase running) due to V_{FB} dropping below $V_{REF} - 25mV$ when APS mode is enabled. 0: disable 1: enable
8	PRD_EXIT_EN	Enable bit for exiting phase-shedding (jumping to full-phase running) due to the PWM interval being shorter than the configured threshold. 0: disable 1: enable
7	OC_EXIT_EN	Enable bit for exiting phase-shedding (jumping to full-phase running) due to phase 1 triggering the valley current limit when the system runs at 1-phase. 0: disable 1: enable
6:1	DROP_PHASE_INTERVAL	Interval time between dropping two adjacent phases when drop-phase mode is dropping sequentially (bit[0] = 1). 1 μs /LSB.
0	DROP_PHASE_MODE	Drop-phase mode selector. 0: phases drop together 1: phases drop one-by-one with interval time determined by bit[6:1]

MFR_REPORT_CTRL (ADh)

This register controls the reporting mode for READ_VIN, READ_VOUT, READ_IOUT, READ_PIN, READ_POUT, READ_EFFICIENCY, READ_TON, and READ_SWITCH_PRD.

Command	MFR_REPORT_CTRL															
Format	Unsigned binary															
Bit	15	14	13	12	11	10	9	8	7	6	5	4	3	2	1	0
Access	r/w	r/w	r/w	r/w	r/w	r/w	r/w	r/w	r/w	r/w	r/w	r/w	r/w	r/w	r/w	r/w
Function	x	x	x	x												

Bits	Bit Name	Description																																
15:12	RESERVED	Unused. X indicates that writes are ignored and reads are always 0.																																
11:10	REPORT_MODE	<p>Reporting mode selector.</p> <p>00: average mode 01: real-time mode 1x: latch mode. Send the command START_CATCH_AVE to trigger the averaging process within the average window. At the end of the average window, the average results are latched.</p> <p>When reporting mode is set to real time or latch, some registers that do not have real time or latch mode report with average mode.</p> <p>READ_TEMPERATURE is always in real-time mode.</p> <table border="1"> <thead> <tr> <th></th> <th>Average mode</th> <th>Real-time mode</th> <th>Latch mode</th> </tr> </thead> <tbody> <tr> <td>READ_VIN</td> <td>✓</td> <td>✓</td> <td>x</td> </tr> <tr> <td>READ_VOUT</td> <td>✓</td> <td>✓</td> <td>x</td> </tr> <tr> <td>READ_IOUT</td> <td>✓</td> <td>✓</td> <td>✓</td> </tr> <tr> <td>READ_TEMPERATURE</td> <td>x</td> <td>✓</td> <td>x</td> </tr> <tr> <td>READ_EFFICIENCY</td> <td>✓</td> <td>x</td> <td>✓</td> </tr> <tr> <td>READ_POUT</td> <td>✓</td> <td>x</td> <td>✓</td> </tr> <tr> <td>READ_PIN</td> <td>✓</td> <td>x</td> <td>✓</td> </tr> </tbody> </table>		Average mode	Real-time mode	Latch mode	READ_VIN	✓	✓	x	READ_VOUT	✓	✓	x	READ_IOUT	✓	✓	✓	READ_TEMPERATURE	x	✓	x	READ_EFFICIENCY	✓	x	✓	READ_POUT	✓	x	✓	READ_PIN	✓	x	✓
	Average mode	Real-time mode	Latch mode																															
READ_VIN	✓	✓	x																															
READ_VOUT	✓	✓	x																															
READ_IOUT	✓	✓	✓																															
READ_TEMPERATURE	x	✓	x																															
READ_EFFICIENCY	✓	x	✓																															
READ_POUT	✓	x	✓																															
READ_PIN	✓	x	✓																															
9:0	AVE_WINDOW	Averaging window for reporting. 100µs/LSB.																																

MFR_PWMVID_TARGET_CTRL (AEh)

This register sets the relationship between the PWM-VID duty and target output voltage.

Command	MFR_PWMVID_TARGET_CTRL															
Format	Unsigned binary															
Bit	15	14	13	12	11	10	9	8	7	6	5	4	3	2	1	0
Access	r/w	r/w	r/w	r/w	r/w	r/w	r/w	r/w	r/w	r/w	r/w	r/w	r/w	r/w	r/w	r/w
Function	x	x	x	x	x											

Bits	Bit Name	Description
15:11	RESERVED	Unused. X indicates that writes are ignored and reads are always 0.
10:9	TON_PRD_FIL_SEL	<p>Time constant of the digital low-pass filter for sensing the PWM frequency and on-time used for efficiency calculation.</p> <p>00: (500kHz / Fs) x 6ms 01: (500kHz / Fs) x 12ms 10: (500kHz / Fs) x 24ms 11: (500kHz / Fs) x 48ms</p> <p>Fs is the configured PWM frequency.</p>

8:6	DVID_FLAG_DELAY	<p>Delay time from when DVID completes to when the internal DVID flag resets. 20µs/LSB.</p> <p>If the output voltage is in PMBus-controlling mode (VID_CONTROL_MODE = 1), this register is ignored (delay time is zero).</p>
5	DUTY_TO_VID_GAIN_MODE	<p>Gain mode selector for target VID calculation. The target output voltage is calculated by the defined register VOUT_MIN (1Fh), real-time PWM-VID on-time, and a GAIN factor as shown below:</p> $\text{VID_TARGET} = \text{PWMVID_ON_TIME} \times \text{GAIN} + \text{VOUT_MIN}$ <p>0: always use the register value from DUTY_TO_VID_GAIN (B3h) 1: update the current GAIN by the real-time calculated value when the error between the latest calculated GAIN and the current GAIN exceeds DUTY_TO_VID_GAIN_HYS (but is still within ±10% deviation from the current GAIN). In this case, the register DUTY_TO_VID_GAIN (B3h) is used as the initial GAIN.</p>
4:3	DUTY_TO_VID_GAIN_FIL_SEL	<p>Averaging window of digital filter for VID_TARGET calculation.</p> <p>00: average of four points 01: average of eight points 10: average of 16 points 11: average of 32 points</p>
2:0	DUTY_TO_VID_GAIN_HYS	<p>Gain hysteresis used to update the current GAIN for the target VID calculation if DUTY_TO_VID_GAIN_SEL = 1. When the error between the latest calculated GAIN and current GAIN exceeds this hysteresis (but is still within the 10% deviation from the current GAIN), the current GAIN is updated by the most-recently calculated one. In this case, the register DUTY_TO_VID_GAIN (B3h) is used as the initial GAIN.</p>

MFR_PWMVID_UP_COMP (AFh)

This register sets VID compensation for upward DVID.

Command	MFR_PWMVID_UP_COMP															
Format	Unsigned binary															
Bit	15	14	13	12	11	10	9	8	7	6	5	4	3	2	1	0
Access	r/w	r/w	r/w	r/w	r/w	r/w	r/w	r/w	r/w	r/w	r/w	r/w	r/w	r/w	r/w	r/w
Function	DVID_UP_CMPN											DVID_UP_END_THRE				

Bits	Bit Name	Description
15:5	DVID_UP_CMPN	<p>PWM-VID duty compensation value based on the desired compensation step. This bit is added in the detected PWM-VID duty during upward DVID.</p> $\text{DVID_UP_CMPN} = \frac{\text{VID_CMPN_STEP} + 2}{\text{VOUT_MAX} - \text{VOUT_MIN}} \times 2^{12}$ <p>VOUT_MAX (24h) and VOUT_MIN (1Fh) are in VID format.</p>
4	DVID_UP_CMPN_EN	<p>Enable bit of the extra VID step for upward DVID.</p> <p>0: disable 1: enable</p>
3:0	DVID_UP_END_THRE	<p>Threshold for the upward DVID ending indicator. During upward DVID, the controller uses the output of the first-stage filter as VO_REF. When the current VO_REF is greater than the calculated VID_TARGET - DVID_UP_END_THRE, this bit switches to the output of the second-stage filter.</p> <p>DVID_UP_START_THRE must be greater than DVID_UP_END_THRE.</p>

MFR_PWMVID_MAX_DUTY (B0h)

This register sets the PWM-VID on-time threshold used to indicate 100% PWM-VID duty.

Command	MFR_PWMVID_MAX_DUTY																	
Format	Unsigned binary																	
Bit	15	14	13	12	11	10	9	8	7	6	5	4	3	2	1	0		
Access	r/w	r/w	r/w	r/w	r/w	r/w	r/w	r/w	r/w	r/w	r/w	r/w	r/w	r/w	r/w	r/w		
Function	x	x	x	x	x	x	PWMVID_MAX_DUTY											

Bits	Bit Name	Description
15:10	RESERVED	Unused. X indicates that writes are ignored and reads are always 0.
9:1	PWMVID_MAX_DUTY	PWM-VID on-time threshold to indicate 100% PWM-VID duty. When the detected PWM-VID on time is greater than this threshold, the controller considers the current PWM-VID duty to be 100%. 10ns/LSB.
0	PWMVID_HIGHLOW_DET_EN	Enable bit for PWM-VID constant high/low detection. 0: disable 1: enable

MFR_PWMVID_FLTR_CTRL1 (B1h)

This register sets the performance of the digital PWM-VID filters.

Command	MFR_PWMVID_FLTR_CTRL1															
Format	Unsigned binary															
Bit	15	14	13	12	11	10	9	8	7	6	5	4	3	2	1	0
Access	r/w	r/w	r/w	r/w	r/w	r/w	r/w	r/w	r/w	r/w	r/w	r/w	r/w	r/w	r/w	r/w
Function																

Bits	Bit Name	Description
15:13	DVID_DOWN_START_THRE	Threshold for the downward DVID starting indicator (DVID_TRIG_MODE = 0). When V_{OUT} is settled, the controller uses the output of the second-stage filter as VO_{REF} . When the calculated VID_{TARGET} is less than the current $VO_{REF} - DVID_DOWN_START_THRE$, the controller enters the downward DVID, and VO_{REF} switches to the first-stage filter output. $DVID_DOWN_START_THRE$ must be greater than $DVID_DOWN_END_THRE$.
12:10	DVID_UP_START_THRE	Threshold for the upward DVID starting indicator (DVID_TRIG_MODE = 0). When V_{OUT} is settled, the controller uses the output of the second-stage filter as VO_{REF} . When the calculated VID_{TARGET} is greater than the current $VO_{REF} + DVID_UP_START_THRE$, the controller enters the upward DVID, and VO_{REF} switches to the output of the first-stage filter. $DVID_UP_START_THRE$ must be greater than $DVID_UP_END_THRE$.
9:7	DVID_DOWN_END_THRE	Threshold for the downward DVID ending indicator. During the downward DVID, the controller uses the output of the first-stage filter as VO_{REF} . When the current VO_{REF} is less than the calculated $VID_{TARGET} + DVID_DOWN_END_THRE$, this bit switches to the output of the second-stage filter. $DVID_DOWN_START_THRE$ must be greater than $DVID_DOWN_END_THRE$.

6:2	FILT2_CHECK_TIME	<p>Check time of the synchronizing function of the second-stage PWM-VID filter to improve output voltage accuracy after DVID. 100µs/LSB.</p> <p>The second-stage PWM-VID filter uses an internal hysteresis module to avoid jitter on its output. When the output remains unchanged for this checking time, the hysteresis module synchronizes its output with the input to eliminate small DC errors.</p>
1:0	SECOND_FIL_AVE	<p>Averaging window of the second-stage PWM-VID filter.</p> <p>00: average of 512 points 01: average of 1024 points 10: average of 2048 points 11: average of 4056 points</p>

MFR_PWMVID_FLTR_CTRL2 (B2h)

This register sets the performance of the digital PWM-VID filters.

Command	MFR_PWMVID_FLTR_CTRL2															
Format	Unsigned binary															
Bit	15	14	13	12	11	10	9	8	7	6	5	4	3	2	1	0
Access	r/w	r/w	r/w	r/w	r/w	r/w	r/w	r/w	r/w	r/w	r/w	r/w	r/w	r/w	r/w	r/w
Function																

Bits	Bit Name	Description
15	DVID_TRIG_MODE	<p>DVID trigger mode selector.</p> <p>0: according to the relationship between the calculated VID_TARGET and current VO_REF 1: according to whether the real-time counted PWM-VID on-time changes more than the threshold set in bit[5:3] or bit[2:0]</p>
14	FILT2_SYNC_EN	<p>Enable bit for the synchronizing function of the second stage PWM-VID filter to improve output voltage accuracy after DVID.</p> <p>0: disable 1: enable</p> <p>The second stage PWM-VID filter uses an internal hysteresis module to avoid jitter on its output. When the output remains unchanged for this checking time, the hysteresis module synchronizes its output with the input to eliminate small DC errors.</p>
13:10	DVID_DOWN_THRE	DVID direction identification threshold for downward DVID. When the current VO_REF is greater than VID_TARGET + DVID_DOWN_THRE, the controller considers the DVID to be downward.
9:6	DVID_UP_THRE	DVID direction identification threshold for upward DVID. When the current VO_REF is less than VID_TARGET - DVID_UP_THRE, the controller considers the DVID to be upward.
5:3	TON_CHANGE_THRE_N	Threshold for the downward DVID starting indicator (DVID_TRIG_MODE = 1). When V _{OUT} is settled, the controller uses the output of the second stage filter as VO_REF. When the detected on-time negative variation of PWM-VID is greater than TON_CHANGE_THRE_N, the controller enters downward DVID, and VO_REF switches to the first- stage filter output. 5ns/LSB.
2:0	TON_CHANGE_THRE_P	Threshold for the upward DVID starting indicator (DVID_TRIG_MODE = 1). When V _{OUT} is settled, the controller uses the output of the second-stage filter as VO_REF. When the detected on-time positive variation of PWM-VID is greater than TON_CHANGE_THRE_P, the controller enters upward DVID, and VO_REF switches to the first-stage filter output. 5ns/LSB.

MFR_DUTY_TO_VID_GAIN (B3h)

This register is the initial parameter for the target voltage calculation.

Command	MFR_DUTY_TO_VID_GAIN															
Format	Unsigned binary															
Bit	15	14	13	12	11	10	9	8	7	6	5	4	3	2	1	0
Access	r/w	r/w	r/w	r/w	r/w	r/w	r/w	r/w	r/w	r/w	r/w	r/w	r/w	r/w	r/w	r/w
Function	x	x	x	x	x	DUTY_TO_VID_GAIN										

Bits	Bit Name	Description
15:11	RESERVED	Unused. X indicates that writes are ignored and reads are always 0.
10:0	DUTY_TO_VID_GAIN	<p>Initial parameter for the VID_TARGET calculation. It is calculated according to the period of PWM-VID, VOUT_MAX, and VOUT_MIN:</p> $DUTY_TO_VID_GAIN = \frac{VOUT_MAX - VOUT_MIN}{PWM_VID_PERIOD(ns) / 5(ns)} \times 2^9$ <p>VOUT_MAX (24h) and VOUT_MIN (1Fh) are in VID format.</p> <p>VID_TARGET is calculated by the register VOUT_MIN (1Fh), real-time PWM-VID on-time, and DUTY_ADC sense of VDIFF, and VFB TO_VID_GAIN:</p> $VID_TARGET = PWM_VID_ON_TIME \times DUTY_TO_VID_GAIN + VOUT_MIN$

MFR_PARM_VOUT_MIN (B4h)

This register is a parameter corresponding to VOUT_MIN.

Command	MFR_PARM_VOUT_MIN															
Format	Unsigned binary															
Bit	15	14	13	12	11	10	9	8	7	6	5	4	3	2	1	0
Access	r/w	r/w	r/w	r/w	r/w	r/w	r/w	r/w	r/w	r/w	r/w	r/w	r/w	r/w	r/w	r/w
Function	PARAM_VOUT_MIN															

Bits	Bit Name	Description
15:0	PARAM_VOUT_MIN	<p>The parameter corresponds to VOUT_MIN:</p> $PARAM_VOUT_MIN = \frac{VOUT_MIN}{VOUT_MAX - VOUT_MIN} \times 2^{11}$ <p>VOUT_MAX (24h) and VOUT_MIN (1Fh) are in VID format.</p>

MFR_PARM_RC_CONST (B5h)

This register is the parameter corresponding to the desired output voltage slew rate during boot-up and DVID.

Command	MFR_PARM_RC_CONST															
Format	Unsigned binary															
Bit	15	14	13	12	11	10	9	8	7	6	5	4	3	2	1	0
Access	r/w	r/w	r/w	r/w	r/w	r/w	r/w	r/w	r/w	r/w	r/w	r/w	r/w	r/w	r/w	r/w
Function	x	x	x	x	BOOT_RC						DVID_RC					

Bits	Bit Name	Description
15:12	RESERVED	Unused. X indicates that writes are ignored and reads are always 0.
11:6	BOOT_RC	<p>The parameter corresponds to the desired time constant of the PWM-VID low-pass filter in the boot-up process:</p> $BOOT_RC = \frac{320(\text{ns})}{\tau_{BOOT}(\text{ns})} \times 2^{11}$ <p>Where τ_{BOOT} is the desired time constant of the PWM-VID low-pass filter in the boot-up process.</p>
5:0	DVID_RC	<p>The parameter corresponds to the desired time constant of the PWM-VID low-pass filter in the DVID process:</p> $DVID_RC = \frac{320(\text{ns})}{\tau_{DVID}(\text{ns})} \times 2^{11}$ <p>Where τ_{DVID} is the desired time constant of the PWM-VID low-pass filter in the DVID process.</p>

MFR_PARAM_VBOOT_DUTY (B6h)

This register is the parameter corresponding to desired V_{BOOT} for PWM-VID mode.

Command	MFR_PARAM_VBOOT_DUTY															
Format	Unsigned binary															
Bit	15	14	13	12	11	10	9	8	7	6	5	4	3	2	1	0
Access	r/w	r/w	r/w	r/w	r/w	r/w	r/w	r/w	r/w	r/w	r/w	r/w	r/w	r/w	r/w	r/w
Function	VBOOT_DUTY															

Bits	Bit Name	Description
15:0	VBOOT_DUTY	<p>The parameter corresponds to the desired V_{BOOT}:</p> $VBOOT_DUTY = \frac{VBOOT-VOUT_MIN}{VOUT_MAX-VOUT_MIN} \times 2^{16}$ <p>V_{BOOT} (B6h), V_{OUT_MAX} (24h), and V_{OUT_MIN} (1Fh) are all in VID format.</p>

MFR_PARAM_SLEW_TRAN (B7h)

This register is the parameter corresponding to DVID_RC in MFR_PARAM_RC_CONST (B5h).

Command	MFR_PARAM_SLEW_TRAN															
Format	Unsigned binary															
Bit	15	14	13	12	11	10	9	8	7	6	5	4	3	2	1	0
Access	r/w	r/w	r/w	r/w	r/w	r/w	r/w	r/w	r/w	r/w	r/w	r/w	r/w	r/w	r/w	r/w
Function	DVID_RC_PARM															

Bits	Bit Name	Description
15:0	DVID_RC_PARM	<p>The parameter corresponds to DVID_RC in MFR_PARAM_RC_CONST (B5h):</p> $DVID_RC_PARM = \frac{1}{DVID_RC \times (VOUT_MAX - VOUT_MIN)} \times 2^{24}$ <p>V_{OUT_MAX} (24h) and V_{OUT_MIN} (1Fh) are all in VID format.</p>

MFR_PARM_BOOT_TRAN (B8h)

This register is the parameter corresponding to BOOT_RC in MFR_PARM_RC_CONST (B5h).

Command	MFR_PARM_BOOT_TRAN															
Format	Unsigned binary															
Bit	15	14	13	12	11	10	9	8	7	6	5	4	3	2	1	0
Access	r/w	r/w	r/w	r/w	r/w	r/w	r/w	r/w	r/w	r/w	r/w	r/w	r/w	r/w	r/w	r/w
Function	BOOT_RC_PARM															

Bits	Bit Name	Description
15:0	BOOT_RC_PARM	<p>The parameter corresponds to BOOT_RC in MFR_PARM_RC_CONST (B5h):</p> $\text{BOOT_RC_PARM} = \frac{1}{\text{BOOT_RC} \times (\text{VOUT_MAX} - \text{VOUT_MIN})} \times 2^{24}$ <p>VOUT_MAX (24h) and VOUT_MIN (1Fh) are all in VID format.</p>

MFR_BOOT_SR (B9h)

This register sets the output voltage slew rate for linear boot-up.

Command	MFR_BOOT_SR																	
Format	Unsigned binary																	
Bit	15	14	13	12	11	10	9	8	7	6	5	4	3	2	1	0		
Access	r/w	r/w	r/w	r/w	r/w	r/w	r/w	r/w	r/w	r/w	r/w	r/w	r/w	r/w	r/w	r/w		
Function	x	x	x	x	x	x	LINEAR_BOOT_SR_CNT											

Bits	Bit Name	Description
9:0	LINEAR_BOOT_SR_CNT	<p>Sets the linear boot-up slew rate.</p> $\text{LINEAR_BOOT_SR_CNT} = \frac{6.25\text{mV}}{\text{SR}_{\text{BOOT}} \times 50\text{ns}}$ <p>Bit[0] of MFR_VR_CONFIG2 (E2h) sets the boot-up and DVID mode. VO_SR_MODE_SEL= 0: linear mode VO_SR_MODE_SEL= 1: R-C filter mode</p> <p>Set LINEAR_BOOT_SR_CNT to 0002h when VO_SR_MODE_SEL= 1 (R-C filter mode).</p>

MFR_SLEW_SR (BAh)

This register sets the output voltage slew rate for linear DVID.

Command	MFR_SLEW_SR																	
Format	Unsigned binary																	
Bit	15	14	13	12	11	10	9	8	7	6	5	4	3	2	1	0		
Access	r/w	r/w	r/w	r/w	r/w	r/w	r/w	r/w	r/w	r/w	r/w	r/w	r/w	r/w	r/w	r/w		
Function	x	x	x	x	x	x	LINEAR_DVID_SR_CNT											

Bits	Bit Name	Description
9:0	LINEAR_DVID_SR_CNT	<p>Sets the linear DVID slew rate.</p> $\text{LINEAR_DVID_SR_CNT} = \frac{6.25\text{mV}}{\text{SR}_{\text{DVID}} \times 50\text{ns}}$ <p>Bit[0] of MFR_VR_CONFIG2 (E2h) sets the boot-up and DVID mode.</p> <p>VO_SR_MODE_SEL= 0: linear mode VO_SR_MODE_SEL= 1: R-C filter mode</p> <p>Set LINEAR_DVID_SR_CNT to 0002h when VO_SR_MODE_SEL= 1 (R-C filter mode).</p>

MFR_VBOOT (BBh)

This register is used to set the boot voltage for PWM-VID mode. It is in VID format.

Command	MFR_VBOOT															
Format	VID															
Bit	15	14	13	12	11	10	9	8	7	6	5	4	3	2	1	0
Access	r/w	r/w	r/w	r/w	r/w	r/w	r/w	r/w	r/w	r/w	r/w	r/w	r/w	r/w	r/w	r/w
Function	x	x	x	x	x	x	x	VBOOT								

Bits	Bit Name	Description
15:9	RESERVED	Unused. X indicates that writes are ignored and reads are always 0.
8:0	VBOOT	Boot voltage for PWM-VID mode. 6.25mV/LSB.

MFR_VID_SD (BCh)

This register sets the VID threshold to set all PWMs to tri-state during soft shutdown or the DVID-to-zero process.

Command	MFR_VID_SD															
Format	VID															
Bit	15	14	13	12	11	10	9	8	7	6	5	4	3	2	1	0
Access	r/w	r/w	r/w	r/w	r/w	r/w	r/w	r/w	r/w	r/w	r/w	r/w	r/w	r/w	r/w	r/w
Function	x	x	x	x	x	x	x	VID_SHUT_DOWN								

Bits	Bit Name	Description
15:9	RESERVED	Unused. X indicates that writes are ignored and reads are always 0.
8:0	VID_SHUT_DOWN	VID threshold to set all PWMs to tri-state during soft shutdown or the DVID-to-zero process. 6.25mV/LSB.

MFR_FS (BDh)

This register sets the PWM frequency.

Command	MFR_FS															
Format	VID															
Bit	15	14	13	12	11	10	9	8	7	6	5	4	3	2	1	0
Access	r/w	r/w	r/w	r/w	r/w	r/w	r/w	r/w	r/w	r/w	r/w	r/w	r/w	r/w	r/w	r/w
Function	x	x	x	x	x	x	x	MFR_FS								

Bits	Bit Name	Description
15:9	RESERVED	Unused. X indicates that writes are ignored and reads are always 0.
8:0	MFR_FS	10kHz/LSB.

MFR_PMBUS_ADDR (BEh)

This register sets the PMBus address for the controller.

Command	MFR_PMBUS_ADDR							
Format	Unsigned binary							
Bit	7	6	5	4	3	2	1	0
Access	r/w	r/w	r/w	r/w	r/w	r/w	r/w	r/w
Function	MODE	ADDR_MSB			ADDR_LSB			

Bits	Bit Name	Description
7	ADDR_LSB_MODE	ADDR_LSB mode selector. 0: set by ADDR 1: set by register
6:4	ADDR_MSB	MSB of address.
3:0	ADDR_LSB	LSB of address.

MFR_VIN_SENSE_OFFSET (BFh)

This register sets input voltage sensing offset and input power loss calibrating parameter.

Command	MFR_VIN_SENSE_OFFSET															
Format	Unsigned binary															
Bit	15	14	13	12	11	10	9	8	7	6	5	4	3	2	1	0
Access	r/w	r/w	r/w	r/w	r/w	r/w	r/w	r/w	r/w	r/w	r/w	r/w	r/w	r/w	r/w	r/w
Function	PWR_LOSS_OFFSET								VIN_SENSE_OFFSET							

Bits	Bit Name	Description
15:8	PWR_LOSS_OFFSET	Power loss offset for the input power report and efficiency calculation. 0.5W/LSB (TOTAL_CURRENT_RESOLUTION = 0) 1W/LSB (TOTAL_CURRENT_RESOLUTION = 1)
7:0	VIN_SENSE_OFFSET	Input voltage sensing offset: $ V_{in_offset} = \frac{1.6 \times VIN_SENSE_OFFSET \times (R_{TOP} + R_{BOTTOM})}{1024 \times R_{BOTTOM}}$ Where V_{in_offset} is the target offset on the input voltage sensing, and R_{TOP} and R_{BOTTOM} are the resistor divider for input voltage sensing. Bit[7] is the sign bit.

MFR_VIN_SCALE_LOOP (C0h)

This register sets the ratio of the resistor divider for the input voltage sensing.

Command	MFR_VIN_SCALE_LOOP							
Format	Unsigned binary							
Bit	7	6	5	4	3	2	1	0
Access	r/w	r/w	r/w	r/w	r/w	r/w	r/w	r/w
Function	VIN_SENSE_SCALE							

Bits	Bit Name	Description
7:0	VIN_SENSE_SCALE	Parameter used to set the input voltage sensing scale. $VIN_SENSE_SCALE = \frac{1024 \times V_{INSEN}}{V_{IN}} = \frac{1024 \times R_{BOTTOM}}{R_{TOP} + R_{BOTTOM}}$

MFR_TEMP_GAIN_OFFSET (C1h)

This register sets the gain and offset for temperature sensing via VTEMP.

Command	MFR_TEMP_GAIN_OFFSET															
Format	Unsigned binary															
Bit	15	14	13	12	11	10	9	8	7	6	5	4	3	2	1	0
Access	r/w	r/w	r/w	r/w	r/w	r/w	r/w	r/w	r/w	r/w	r/w	r/w	r/w	r/w	r/w	r/w
Function	x	VTEMP_OFFSET							VTEMP_GAIN							

Bits	Bit Name	Description
15	RESERVED	Unused. X indicates that writes are ignored and reads are always 0.
14:8	VTEMP_OFFSET	Offset used to report the temperature from VTEMP: $VTEMP_OFFSET = \frac{DrMOS_TEMP_OFFSET}{DrMOS_TEMP_GAIN}$ Assuming that: $VTEMP = DrMOS_TEMP_GAIN \times Temperature - DrMOS_TEMP_OFFSET$
7:0	VTEMP_GAIN	Gain used to report the temperature from VTEMP. VTEMP has an internal 1/2 divider before ADC: $VTEMP_GAIN = \frac{2 \times 1.6 \times 2^9 \times 1000}{DrMOS_TEMP_GAIN \times 1024}$ Assuming that: $VTEMP = DrMOS_TEMP_GAIN \times Temperature - DrMOS_TEMP_OFFSET$

MFR_CUR_GAIN (C2h)

This register sets the gain for phase-current sensing.

Command	MFR_CUR_GAIN															
Format	Unsigned binary															
Bit	15	14	13	12	11	10	9	8	7	6	5	4	3	2	1	0
Access	r/w	r/w	r/w	r/w	r/w	r/w	r/w	r/w	r/w	r/w	r/w	r/w	r/w	r/w	r/w	r/w
Function	x	x	x	x	x	x	PHASE_CUR_GAIN									

Bits	Bit Name	Description
15:10	RESERVED	Unused. X indicates that writes are ignored and reads are always 0.
9:0	PHASE_CUR_GAIN	Gain for phase-current sensing. $PHASE_CUR_GAIN = K_{CS} \times R_{CS} \times 2^{13}$ (PHASE_CURRENT_RESOLUTION = 0) $PHASE_CUR_GAIN = K_{CS} \times R_{CS} \times 2^{14}$ (PHASE_CURRENT_RESOLUTION = 1) Where R_{CS} is the phase-current sensing resistor, and K_{CS} is the current sensing gain of the DrMOS.

MFR_BLANK_TIME (C5h)

This register sets the minimum interval time between consecutive phases' PWM rising edges and the discharging time of slope compensation capacitors.

Command	MFR_BLANK_TIME															
Format	Unsigned binary															
Bit	15	14	13	12	11	10	9	8	7	6	5	4	3	2	1	0
Access	r/w	r/w	r/w	r/w	r/w	r/w	r/w	r/w	r/w	r/w	r/w	r/w	r/w	r/w	r/w	r/w
Function	x	x	x	x	SLOPE_BLANK_TIME						PHASE_BLANK_TIME					

Bits	Bit Name	Description
15:12	RESERVED	Unused. X indicates that writes are ignored and reads are always 0.
11:6	SLOPE_BLANK_TIME	Discharging time of slope compensation capacitors. 5ns/LSB. SLOPE_BLANK_TIME <i>must</i> be less than or equal to PHASE_BLANK_TIME.
5:0	PHASE_BLANK_TIME	Minimum interval time between consecutive phases' PWM rising edges. 5ns/LSB. PHASE_BLANK_TIME <i>must</i> be greater than SLOPE_BLANK_TIME.

MFR_SLOPE_SR_DCM (C6h)

This register sets the slew rate of slope compensation for 1-phase DCM.

Command	MFR_SLOPE_SR_DCM															
Format	Unsigned binary															
Bit	15	14	13	12	11	10	9	8	7	6	5	4	3	2	1	0
Access	r/w	r/w	r/w	r/w	r/w	r/w	r/w	r/w	r/w	r/w	r/w	r/w	r/w	r/w	r/w	r/w
Function	x	x	x	x	x	x	x	x	x	x	CURRENT_SOURCE					

Bits	Bit Name	Description
15:6	RESERVED	Unused. X indicates that writes are ignored and reads are always 0.
5:0	CURRENT_SOURCE	Current source value for slope compensation. 0.25µA/LSB.

Calculate the slope compensation slew rate with Equation (23):

$$V_{\text{SLOPE@DCM}} = \frac{0.25(\mu\text{A}) \times \text{CURRENT_SOURCE}}{16 \times 1.85(\text{pF})} \times (T_{\text{SW}} - T_{\text{BLANK}}) \quad (23)$$

Where $V_{\text{SLOPE@DCM}}$ is the desired voltage of slope compensation for 1-phase DCM, T_{SW} is the PWM period determined by register MFR_FS (BDh), and T_{BLANK} is SLOPE_BLANK_TIME set in register MFR_BLANK_TIME (C5h).

If setting VDIFF_GAIN_SEL (2Ah) = 1 to get a half gain for the remote sense amplifier, V_{SLOPE} should be doubled.

MFR_SLOPE_CNT_DCM (C7h)

This register sets the maximum ramping time of slope compensation for 1-phase DCM. Once the timer is over, the current source turns off, and the slope compensation voltage is held.

Command	MFR_SLOPE_CNT_DCM																	
Format	Unsigned binary																	
Bit	15	14	13	12	11	10	9	8	7	6	5	4	3	2	1	0		
Access	r/w	r/w	r/w	r/w	r/w	r/w	r/w	r/w	r/w	r/w	r/w	r/w	r/w	r/w	r/w	r/w		
Function	x	x	x	x	x	x	SLOPE_CNT											

Bits	Bit Name	Description
15:10	RESERVED	Unused. X indicates that writes are ignored and reads are always 0.
9:0	SLOPE_CNT	Maximum ramping time of slope compensation for 1-phase DCM. 5ns/LSB. $\text{SLOPE_CNT} = \frac{1.3 \times (T_{\text{SW}} - T_{\text{BLANK}})(\text{ns})}{5(\text{ns})}$ Where T_{SW} is the PWM period determined by register MFR_FS (BDh), and T_{BLANK} is SLOPE_BLANK_TIME set in register MFR_BLANK_TIME (C5h).

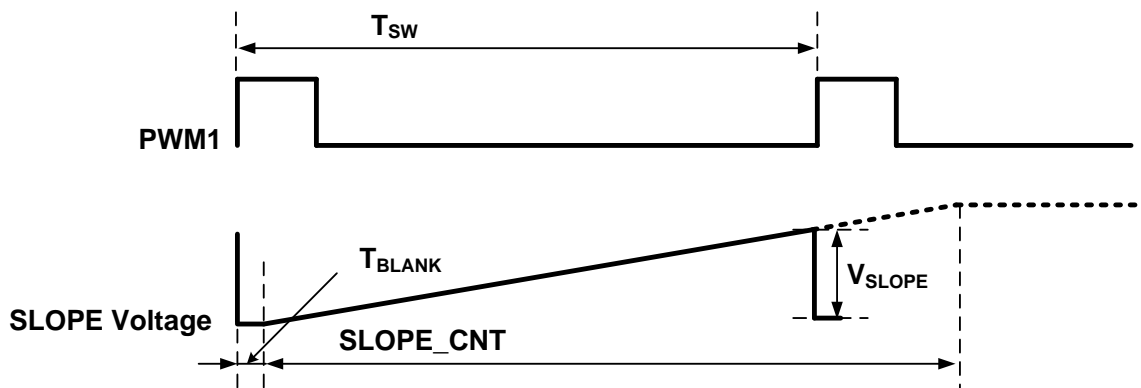

Figure 19: Slope Compensation for 1-Phase DCM

MFR_SLOPE_SR_10P (C8h)

This register sets the slew rate of slope compensation for 10-phase status.

Command	MFR_SLOPE_SR_10P															
Format	Unsigned binary															
Bit	15	14	13	12	11	10	9	8	7	6	5	4	3	2	1	0
Access	r/w	r/w	r/w	r/w	r/w	r/w	r/w	r/w	r/w	r/w	r/w	r/w	r/w	r/w	r/w	r/w
Function	x	x	x	x	x	x	x	x				x				

Bits	Bit Name	Description
15:9	RESERVED	Unused. X indicates that writes are ignored and reads are always 0.
8:6	RESERVED	Unused. X indicates that writes are ignored and reads are always 0.
5:0	RESERVED	Unused. X indicates that writes are ignored and reads are always 0.

Calculate the slope compensation slew rate with Equation (24):

$$V_{\text{SLOPE@10P}} = \frac{0.25(\mu\text{A}) \times \text{CURRENT_SOURCE}}{(8 - \text{CAP}) \times 1.85(\text{pF})} \times \left(\frac{T_{\text{SW}}}{10} - T_{\text{BLANK}} \right) \quad (24)$$

Where $V_{\text{SLOPE@10P}}$ is the desired voltage of slope compensation for 10-phase, T_{SW} is the PWM period determined by register MFR_FS (BDh), and T_{BLANK} is SLOPE_BLANK_TIME set in register MFR_BLANK_TIME (C5h).

If setting VDIFF_GAIN_SEL (2Ah) = 1 to get a half gain for the remote sense amplifier, V_{SLOPE} should be doubled.

MFR_SLOPE_CNT_10P (C9h)

This register sets the maximum ramping time of slope compensation for 10-phase status. Once the timer ends, the current source turns off, and the slope compensation voltage is held.

Command	MFR_SLOPE_CNT_10P															
Format	Unsigned binary															
Bit	15	14	13	12	11	10	9	8	7	6	5	4	3	2	1	0
Access	r/w	r/w	r/w	r/w	r/w	r/w	r/w	r/w	r/w	r/w	r/w	r/w	r/w	r/w	r/w	r/w
Function	x	x	x	x	x	x	x	x								

Bits	Bit Name	Description
15:8	RESERVED	Unused. X indicates that writes are ignored and reads are always 0.
7:0	RESERVED	Unused. X indicates that writes are ignored and reads are always 0.

MFR_SLOPE_SR_9P (CAh)

This register sets the slew rate of slope compensation for 9-phase status.

Command	MFR_SLOPE_SR_9P															
Format	Unsigned binary															
Bit	15	14	13	12	11	10	9	8	7	6	5	4	3	2	1	0
Access	r/w	r/w	r/w	r/w	r/w	r/w	r/w	r/w	r/w	r/w	r/w	r/w	r/w	r/w	r/w	r/w
Function	x	x	x	x	x	x	x									

Bits	Bit Name	Description
15:9	RESERVED	Unused. X indicates that writes are ignored and reads are always 0.
8:6	RESERVED	Unused. X indicates that writes are ignored and reads are always 0.
5:0	RESERVED	Unused. X indicates that writes are ignored and reads are always 0.

Calculate the slope compensation slew rate with Equation (25):

$$V_{\text{SLOPE@9P}} = \frac{0.25(\mu\text{A}) \times \text{CURRENT_SOURCE}}{(8 - \text{CAP}) \times 1.85(\text{pF})} \times \left(\frac{T_{\text{SW}}}{9} - T_{\text{BLANK}} \right) \quad (25)$$

Where $V_{\text{SLOPE@9P}}$ is the desired voltage of slope compensation for 9-phase status, T_{SW} is the PWM period determined by register MFR_FS (BDh), and T_{BLANK} is SLOPE_BLANK_TIME set in register MFR_BLANK_TIME (C5h).

If setting VDIFF_GAIN_SEL (2Ah) = 1 to get a half gain for the remote sense amplifier, V_{SLOPE} should be doubled.

MFR_SLOPE_CNT_9P (CBh)

This register sets the maximum ramping time of slope compensation for 9-phase status. Once the timer is over, the current source turns off, and the slope compensation voltage is held.

Command	MFR_SLOPE_CNT_9P															
Format	Unsigned binary															
Bit	15	14	13	12	11	10	9	8	7	6	5	4	3	2	1	0
Access	r/w	r/w	r/w	r/w	r/w	r/w	r/w	r/w	r/w	r/w	r/w	r/w	r/w	r/w	r/w	r/w
Function	x	x	x	x	x	x	x	x								x

Bits	Bit Name	Description
15:8	RESERVED	Unused. X indicates that writes are ignored and reads are always 0.
7:0	RESERVED	Unused. X indicates that writes are ignored and reads are always 0.

MFR_SLOPE_SR_8P (CCh)

This register sets the slew rate of slope compensation for 8-phase status.

Command	MFR_SLOPE_SR_8P															
Format	Unsigned binary															
Bit	15	14	13	12	11	10	9	8	7	6	5	4	3	2	1	0
Access	r/w	r/w	r/w	r/w	r/w	r/w	r/w	r/w	r/w	r/w	r/w	r/w	r/w	r/w	r/w	r/w
Function	x	x	x	x	x	x	x		x							x

Bits	Bit Name	Description
15:9	RESERVED	Unused. X indicates that writes are ignored and reads are always 0.
8:6	RESERVED	Unused. X indicates that writes are ignored and reads are always 0.
5:0	RESERVED	Unused. X indicates that writes are ignored and reads are always 0.

Calculate the slope compensation slew rate with Equation (26):

$$V_{\text{SLOPE@8P}} = \frac{0.25(\mu\text{A}) \times \text{CURRENT_SOURCE}}{(8 - \text{CAP}) \times 1.85(\text{pF})} \times \left(\frac{T_{\text{SW}}}{8} - T_{\text{BLANK}} \right) \quad (26)$$

Where $V_{\text{SLOPE@8P}}$ is the desired voltage of slope compensation for 8-phase status, T_{SW} is the PWM period determined by register MFR_FS (BDh), and T_{BLANK} is SLOPE_BLANK_TIME set in register MFR_BLANK_TIME (C5h).

If setting VDIFF_GAIN_SEL (2Ah) = 1 to get a half gain for the remote sense amplifier, V_{SLOPE} should be doubled.

MFR_SLOPE_CNT_8P (CDh)

This register sets the maximum ramping time of slope compensation for 8-phase status. Once the timer is over, the current source turns off, and the slope compensation voltage is held.

Command	MFR_SLOPE_CNT_8P															
Format	Unsigned binary															
Bit	15	14	13	12	11	10	9	8	7	6	5	4	3	2	1	0
Access	r/w	r/w	r/w	r/w	r/w	r/w	r/w	r/w	r/w	r/w	r/w	r/w	r/w	r/w	r/w	r/w
Function	x	x	x	x	x	x	x	x								x

Bits	Bit Name	Description
15:8	RESERVED	Unused. X indicates that writes are ignored and reads are always 0.
7:0	RESERVED	Unused. X indicates that writes are ignored and reads are always 0.

MFR_SLOPE_SR_7P (CEh)

This register sets the slew rate of slope compensation for 7-phase status.

Command	MFR_SLOPE_SR_7P															
Format	Unsigned binary															
Bit	15	14	13	12	11	10	9	8	7	6	5	4	3	2	1	0
Access	r/w	r/w	r/w	r/w	r/w	r/w	r/w	r/w	r/w	r/w	r/w	r/w	r/w	r/w	r/w	r/w
Function	x	x	x	x	x	x	x	x			x					

Bits	Bit Name	Description
15:9	RESERVED	Unused. X indicates that writes are ignored and reads are always 0.
8:6	RESERVED	Unused. X indicates that writes are ignored and reads are always 0.
5:0	RESERVED	Unused. X indicates that writes are ignored and reads are always 0.

Calculate the slope compensation slew rate with Equation (27):

$$V_{\text{SLOPE@7P}} = \frac{0.25(\mu\text{A}) \times \text{CURRENT_SOURCE}}{(8 - \text{CAP}) \times 1.85(\text{pF})} \times \left(\frac{T_{\text{SW}}}{7} - T_{\text{BLANK}} \right) \quad (27)$$

Where $V_{\text{SLOPE@7P}}$ is the desired voltage of slope compensation for 7-phase status, T_{SW} is the PWM period determined by register MFR_FS (BDh), and T_{BLANK} is SLOPE_BLANK_TIME set in register MFR_BLANK_TIME (C5h).

If setting VDIFF_GAIN_SEL (2Ah) = 1 to get a half gain for the remote sense amplifier, V_{SLOPE} should be doubled.

MFR_SLOPE_CNT_7P (CFh)

This register sets the maximum ramping time of slope compensation for 7-phase status. Once the timer is over, the current source turns off, and the slope compensation voltage is held.

Command	MFR_SLOPE_CNT_7P															
Format	Unsigned binary															
Bit	15	14	13	12	11	10	9	8	7	6	5	4	3	2	1	0
Access	r/w	r/w	r/w	r/w	r/w	r/w	r/w	r/w	r/w	r/w	r/w	r/w	r/w	r/w	r/w	r/w
Function	x	x	x	x	x	x	x	x	x							

Bits	Bit Name	Description
15:8	RESERVED	Unused. X indicates that writes are ignored and reads are always 0.
7:0	RESERVED	Unused. X indicates that writes are ignored and reads are always 0.

MFR_SLOPE_SR_6P (D0h)

This register sets the slew rate of slope compensation for 6-phase status.

Command	MFR_SLOPE_SR_6P															
Format	Unsigned binary															
Bit	15	14	13	12	11	10	9	8	7	6	5	4	3	2	1	0
Access	r/w	r/w	r/w	r/w	r/w	r/w	r/w	r/w	r/w	r/w	r/w	r/w	r/w	r/w	r/w	r/w
Function	x	x	x	x	x	x	x	x			x					

Bits	Bit Name	Description
15:9	RESERVED	Unused. X indicates that writes are ignored and reads are always 0.
8:6	RESERVED	Unused. X indicates that writes are ignored and reads are always 0.
5:0	RESERVED	Unused. X indicates that writes are ignored and reads are always 0.

Calculate the slope compensation slew rate with Equation (28):

$$V_{\text{SLOPE@6P}} = \frac{0.25(\mu\text{A}) \times \text{CURRENT_SOURCE}}{(8 - \text{CAP}) \times 1.85(\text{pF})} \times \left(\frac{T_{\text{SW}}}{6} - T_{\text{BLANK}} \right) \quad (28)$$

Where $V_{\text{SLOPE@6P}}$ is the desired slope compensation voltage for 6-phase status, T_{SW} is the PWM period determined by register MFR_FS (BDh), and T_{BLANK} is SLOPE_BLANK_TIME set in register MFR_BLANK_TIME (C5h).

If setting VDIFF_GAIN_SEL (2Ah) = 1 to get a half gain for the remote sense amplifier, V_{SLOPE} should be doubled.

MFR_SLOPE_CNT_6P (D1h)

This register sets the maximum slope compensation ramping time for 6-phase status. Once the timer is over, the current source turns off, and the slope compensation voltage is held.

Command	MFR_SLOPE_CNT_6P															
Format	Unsigned binary															
Bit	15	14	13	12	11	10	9	8	7	6	5	4	3	2	1	0
Access	r/w	r/w	r/w	r/w	r/w	r/w	r/w	r/w	r/w	r/w	r/w	r/w	r/w	r/w	r/w	r/w
Function	x	x	x	x	x	x	x	x	x							

Bits	Bit Name	Description
15:8	RESERVED	Unused. X indicates that writes are ignored and reads are always 0.
7:0	RESERVED	Unused. X indicates that writes are ignored and reads are always 0.

MFR_SLOPE_SR_5P (D2h)

This register sets the slope compensation slew rate for 5-phase status.

Command	MFR_SLOPE_SR_5P															
Format	Unsigned binary															
Bit	15	14	13	12	11	10	9	8	7	6	5	4	3	2	1	0
Access	r/w	r/w	r/w	r/w	r/w	r/w	r/w	r/w	r/w	r/w	r/w	r/w	r/w	r/w	r/w	r/w
Function	x	x	x	x	x	x	x	x			x					

Bits	Bit Name	Description
15:9	RESERVED	Unused. X indicates that writes are ignored and reads are always 0.
8:6	RESERVED	Unused. X indicates that writes are ignored and reads are always 0.
5:0	RESERVED	Unused. X indicates that writes are ignored and reads are always 0.

Calculate the slope compensation slew rate with Equation (29):

$$V_{\text{SLOPE@5P}} = \frac{0.25(\mu\text{A}) \times \text{CURRENT_SOURCE}}{(8 - \text{CAP}) \times 1.85(\text{pF})} \times \left(\frac{T_{\text{SW}}}{5} - T_{\text{BLANK}} \right) \quad (29)$$

Where $V_{\text{SLOPE@5P}}$ is the desired slope compensation voltage for 5-phase status, T_{SW} is the PWM period determined by register MFR_FS (BDh), and T_{BLANK} is SLOPE_BLANK_TIME set in register MFR_BLANK_TIME (C5h).

If setting VDIFF_GAIN_SEL (2Ah) = 1 to get a half gain for the remote sense amplifier, V_{SLOPE} should be doubled.

MFR_SLOPE_CNT_5P (D3h)

This register sets the maximum slope compensation ramping time for 5-phase status. Once the timer is over, the current source turns off, and the slope compensation voltage is held.

Command	MFR_SLOPE_CNT_5P															
Format	Unsigned binary															
Bit	15	14	13	12	11	10	9	8	7	6	5	4	3	2	1	0
Access	r/w	r/w	r/w	r/w	r/w	r/w	r/w	r/w	r/w	r/w	r/w	r/w	r/w	r/w	r/w	r/w
Function	x	x	x	x	x	x	x									x

Bits	Bit Name	Description
15:8	RESERVED	Unused. X indicates that writes are ignored and reads are always 0.
7:0	RESERVED	Unused. X indicates that writes are ignored and reads are always 0.

MFR_SLOPE_SR_4P (D4h)

This register sets the slope compensation slew rate for 4-phase status.

Command	MFR_SLOPE_SR_4P															
Format	Unsigned binary															
Bit	15	14	13	12	11	10	9	8	7	6	5	4	3	2	1	0
Access	r/w	r/w	r/w	r/w	r/w	r/w	r/w	r/w	r/w	r/w	r/w	r/w	r/w	r/w	r/w	r/w
Function	x	x	x	x	x	x	x									

Bits	Bit Name	Description
15:9	RESERVED	Unused. X indicates that writes are ignored and reads are always 0.
8:6	CAP	Capacitor value for slope compensation. 1.85pF/LSB.
5:0	CURRENT_SOURCE	Current source value for slope compensation. 0.25µA/LSB.

Calculate the slope compensation slew rate with Equation (30):

$$V_{\text{SLOPE@4P}} = \frac{0.25(\mu\text{A}) \times \text{CURRENT_SOURCE}}{(8 - \text{CAP}) \times 1.85(\text{pF})} \times \left(\frac{T_{\text{SW}}}{4} - T_{\text{BLANK}} \right) \quad (30)$$

Where $V_{\text{SLOPE@4P}}$ is the desired slope compensation voltage for 4-phase status, T_{SW} is the PWM period determined by register MFR_FS (BDh), and T_{BLANK} is SLOPE_BLANK_TIME set in register MFR_BLANK_TIME (C5h).

If setting VDIFF_GAIN_SEL (2Ah) = 1 to get a half gain for the remote sense amplifier, V_{SLOPE} should be doubled.

MFR_SLOPE_CNT_4P (D5h)

This register sets the maximum slope compensation ramping time for 4-phase status. Once the timer is over, the current source turns off, and the slope compensation voltage is held.

Command	MFR_SLOPE_CNT_4P																		
Format	Unsigned binary																		
Bit	15	14	13	12	11	10	9	8	7	6	5	4	3	2	1	0			
Access	r/w	r/w	r/w	r/w	r/w	r/w	r/w	r/w	r/w	r/w	r/w	r/w	r/w	r/w	r/w	r/w			
Function	x	x	x	x	x	x	SLOPE_CNT												

Bits	Bit Name	Description
15:8	RESERVED	Unused. X indicates that writes are ignored and reads are always 0.
7:0	SLOPE_CNT	<p>Maximum ramping time of slope compensation for 4-phase status. 5ns/LSB.</p> $\text{SLOPE_CNT} = \frac{1.3 \times \left(\frac{T_{\text{SW}}}{4} - T_{\text{BLANK}} \right) (\text{ns})}{5(\text{ns})}$ <p>Where T_{SW} is the PWM period determined by register MFR_FS (BDh), and T_{BLANK} is SLOPE_BLANK_TIME set in register MFR_BLANK_TIME (C5h).</p>

MFR_SLOPE_SR_3P (D6h)

This register sets the slope compensation slew rate for 3-phase status.

Command	MFR_SLOPE_SR_3P																
Format	Unsigned binary																
Bit	15	14	13	12	11	10	9	8	7	6	5	4	3	2	1	0	
Access	r/w	r/w	r/w	r/w	r/w	r/w	r/w	r/w	r/w	r/w	r/w	r/w	r/w	r/w	r/w	r/w	
Function	x	x	x	x	x	x	CAP				CURRENT_SOURCE						

Bits	Bit Name	Description
15:10	RESERVED	Unused. X indicates that writes are ignored and reads are always 0.
9:6	CAP	Capacitor value for slope compensation. 1.85pF/LSB.
5:0	CURRENT_SOURCE	Current source value for slope compensation. 0.25μA/LSB.

Calculate the slope compensation slew rate with Equation (31):

$$V_{\text{SLOPE@3P}} = \frac{0.25(\mu\text{A}) \times \text{CURRENT_SOURCE}}{(16 - \text{CAP}) \times 1.85(\text{pF})} \times \left(\frac{T_{\text{SW}}}{3} - T_{\text{BLANK}} \right) \quad (31)$$

Where $V_{\text{SLOPE@3P}}$ is the desired slope compensation voltage for 3-phase status, T_{SW} is the PWM period determined by register MFR_FS (BDh), and T_{BLANK} is SLOPE_BLANK_TIME set in register MFR_BLANK_TIME (C5h).

If setting VDIFF_GAIN_SEL (2Ah) = 1 to get a half gain for the remote sense amplifier, V_{SLOPE} should be doubled.

MFR_SLOPE_CNT_3P (D7h)

This register sets the maximum slope compensation ramping time for 3-phase status. Once the timer is over, the current source turns off, and the slope compensation voltage is held.

Command	MFR_SLOPE_CNT_3P																	
Format	Unsigned binary																	
Bit	15	14	13	12	11	10	9	8	7	6	5	4	3	2	1	0		
Access	r/w	r/w	r/w	r/w	r/w	r/w	r/w	r/w	r/w	r/w	r/w	r/w	r/w	r/w	r/w	r/w		
Function	x	x	x	x	x	x	SLOPE_CNT											

Bits	Bit Name	Description
15:8	RESERVED	Unused. X indicates that writes are ignored and reads are always 0.
7:0	SLOPE_CNT	<p>Maximum ramping time of slope compensation for 3-phase status. 5ns/LSB.</p> $\text{SLOPE_CNT} = \frac{1.3 \times \left(\frac{T_{\text{SW}}}{3} - T_{\text{BLANK}} \right) (\text{ns})}{5(\text{ns})}$ <p>Where T_{SW} is the PWM period determined by register MFR_FS (BDh), and T_{BLANK} is SLOPE_BLANK_TIME set in register MFR_BLANK_TIME (C5h).</p>

MFR_SLOPE_SR_2P (D8h)

This register sets the slope compensation slew rate for 2-phase status.

Command	MFR_SLOPE_SR_2P															
Format	Unsigned binary															
Bit	15	14	13	12	11	10	9	8	7	6	5	4	3	2	1	0
Access	r/w	r/w	r/w	r/w	r/w	r/w	r/w	r/w	r/w	r/w	r/w	r/w	r/w	r/w	r/w	r/w
Function	x	x	x	x	x	x	CAP				CURRENT_SOURCE					

Bits	Bit Name	Description
15:10	RESERVED	Unused. X indicates that writes are ignored and reads are always 0.
9:6	CAP	Capacitor value for slope compensation. 1.85pF/LSB.
5:0	CURRENT_SOURCE	Current source value for slope compensation. 0.25μA/LSB.

Calculate the slope compensation slew rate with Equation (32):

$$V_{\text{SLOPE@2P}} = \frac{0.25(\mu\text{A}) \times \text{CURRENT_SOURCE}}{(16 - \text{CAP}) \times 1.85(\text{pF})} \times \left(\frac{T_{\text{SW}}}{2} - T_{\text{BLANK}} \right) \quad (32)$$

Where $V_{\text{SLOPE@2P}}$ is the desired slope compensation voltage for 2-phase status, T_{SW} is the PWM period determined by register MFR_FS (BDh), T_{BLANK} is SLOPE_BLANK_TIME set in register MFR_BLANK_TIME (C5h).

If setting VDIFF_GAIN_SEL (2Ah) = 1 to get a half gain for the remote sense amplifier, V_{SLOPE} should be doubled.

MFR_SLOPE_CNT_2P (D9h)

This register sets the maximum slope compensation ramping time for 2-phase status. Once the timer is over, the current source turns off, and the slope compensation voltage is held.

Command	MFR_SLOPE_CNT_2P															
Format	Unsigned binary															
Bit	15	14	13	12	11	10	9	8	7	6	5	4	3	2	1	0
Access	r/w	r/w	r/w	r/w	r/w	r/w	r/w	r/w	r/w	r/w	r/w	r/w	r/w	r/w	r/w	r/w
Function	x	x	x	x	x	x										

Bits	Bit Name	Description
15:8	RESERVED	Unused. X indicates that writes are ignored and reads are always 0.
7:0	SLOPE_CNT	<p>Maximum ramping time of slope compensation for 2-phase status. 5ns/LSB.</p> $\text{SLOPE_CNT} = \frac{1.3 \times \left(\frac{T_{\text{SW}}}{2} - T_{\text{BLANK}} \right) (\text{ns})}{5(\text{ns})}$ <p>Where T_{SW} is the PWM period determined by register MFR_FS (BDh), and T_{BLANK} is SLOPE_BLANK_TIME set in register MFR_BLANK_TIME (C5h).</p>

MFR_SLOPE_SR_1P (DAh)

This register sets the slope compensation slew rate for 1-phase CCM status.

Command	MFR_SLOPE_SR_1P															
Format	Unsigned binary															
Bit	15	14	13	12	11	10	9	8	7	6	5	4	3	2	1	0
Access	r/w	r/w	r/w	r/w	r/w	r/w	r/w	r/w	r/w	r/w	r/w	r/w	r/w	r/w	r/w	r/w
Function	x	x	x	x	x	x	x	x	x							

Bits	Bit Name	Description
15:7	RESERVED	Unused. X indicates that writes are ignored and reads are always 0.
6	CAP	Capacitor value for slope compensation. 1.85pF/LSB.
5:0	CURRENT_SOURCE	Current source value for slope compensation. 0.25μA/LSB.

Calculate the slope compensation slew rate with Equation (33):

$$V_{\text{SLOPE@1P}} = \frac{0.25(\mu\text{A}) \times \text{CURRENT_SOURCE}}{(16 - \text{CAP}) \times 1.85(\text{pF})} \times (T_{\text{SW}} - T_{\text{BLANK}}) \quad (33)$$

Where $V_{\text{SLOPE@1P}}$ is desired slope compensation voltage for 1-phase CCM status, T_{SW} is the PWM period determined by register MFR_FS (BDh), and T_{BLANK} is SLOPE_BLANK_TIME set in register MFR_BLANK_TIME (C5h).

If setting VDIFF_GAIN_SEL (2Ah) = 1 to get a half gain for the remote sense amplifier, V_{SLOPE} should be doubled.

MFR_SLOPE_CNT_1P (DBh)

This register sets the maximum slope compensation ramping time for 1-phase CCM status. Once the timer is over, the current source turns off, and the slope compensation voltage is held.

Command	MFR_SLOPE_CNT_1P																		
Format	Unsigned binary																		
Bit	15	14	13	12	11	10	9	8	7	6	5	4	3	2	1	0			
Access	r/w	r/w	r/w	r/w	r/w	r/w	r/w	r/w	r/w	r/w	r/w	r/w	r/w	r/w	r/w	r/w			
Function	x	x	x	x	x	x	SLOPE_CNT												

Bits	Bit Name	Description
15:8	RESERVED	Unused. X indicates that writes are ignored and reads are always 0.
7:0	SLOPE_CNT	<p>Maximum ramping time of slope compensation for 1-phase CCM status. 5ns/LSB.</p> $\text{SLOPE_CNT} = \frac{1.3 \times (T_{\text{SW}} - T_{\text{BLANK}})(\text{ns})}{5(\text{ns})}$ <p>Where T_{SW} is the PWM period determined by register MFR_FS (BDh), and T_{BLANK} is SLOPE_BLANK_TIME set in register MFR_BLANK_TIME (C5h).</p>

MFR_SLOPE_TRIM1 (DDh)

This register is used to calibrate the V_{OUT} offset caused by the slope compensation and V_{OUT} ripple.

Command	MFR_SLOPE_TRIM1															
Format	Unsigned binary															
Bit	15	14	13	12	11	10	9	8	7	6	5	4	3	2	1	0
Access	r/w	r/w	r/w	r/w	r/w	r/w	r/w	r/w	r/w	r/w	r/w	r/w	r/w	r/w	r/w	r/w
Function	x	VTRIM_2P					VTRIM_1P					VTRIM_DCM				

Bits	Bit Name	Description
15	RESERVED	Unused. X indicates that writes are ignored and reads are always 0.
14:10	VTRIM_2P	<p>Output voltage calibration value for 2-phase status.</p> <p>2.35mV/LSB, when VDIFF_GAIN_SEL (2Ah) = 0 4.7mV/LSB, when VDIFF_GAIN_SEL (2Ah) = 1</p>
9:5	VTRIM_1P	<p>Output voltage calibration value for 1-phase CCM status.</p> <p>2.35mV/LSB, when VDIFF_GAIN_SEL (2Ah) = 0 4.7mV/LSB, when VDIFF_GAIN_SEL (2Ah) = 1</p>
4:0	VTRIM_DCM	<p>Output voltage calibration value for 1-phase DCM status.</p> <p>2.35mV/LSB, when VDIFF_GAIN_SEL (2Ah) = 0 4.7mV/LSB, when VDIFF_GAIN_SEL (2Ah) = 1</p>

MFR_SLOPE_TRIM2 (DEh)

This register is used to calibrate the V_{OUT} offset caused by the slope compensation and V_{OUT} ripple.

Command	MFR_SLOPE_TRIM2															
Format	Unsigned binary															
Bit	15	14	13	12	11	10	9	8	7	6	5	4	3	2	1	0
Access	r/w	r/w	r/w	r/w	r/w	r/w	r/w	r/w	r/w	r/w	r/w	r/w	r/w	r/w	r/w	r/w
Function	x	x				VTRIM_4P						VTRIM_3P				

Bits	Bit Name	Description
15	RESERVED	Unused. X indicates that writes are ignored and reads are always 0.
14:10	RESERVED	Unused. X indicates that writes are ignored and reads are always 0.
9:5	VTRIM_4P	Output voltage calibration value for 4-phase status. 2.35mV/LSB, when VDIFF_GAIN_SEL (2Ah) = 0 4.7mV/LSB, when VDIFF_GAIN_SEL (2Ah) = 1
4:0	VTRIM_3P	Output voltage calibration value for 3-phase status. 2.35mV/LSB, when VDIFF_GAIN_SEL (2Ah) = 0 4.7mV/LSB, when VDIFF_GAIN_SEL (2Ah) = 1

MFR_SLOPE_TRIM3 (DFh)

This register is used to calibrate V_{OUT} offset caused by the slope compensation and V_{OUT} ripple.

Command	MFR_SLOPE_TRIM3															
Format	Unsigned binary															
Bit	15	14	13	12	11	10	9	8	7	6	5	4	3	2	1	0
Access	r/w	r/w	r/w	r/w	r/w	r/w	r/w	r/w	r/w	r/w	r/w	r/w	r/w	r/w	r/w	r/w
Function	x	x				x						x				

Bits	Bit Name	Description
15	RESERVED	Unused. X indicates that writes are ignored and reads are always 0.
14:10	RESERVED	Unused. X indicates that writes are ignored and reads are always 0.
9:5	RESERVED	Unused. X indicates that writes are ignored and reads are always 0.
4:0	RESERVED	Unused. X indicates that writes are ignored and reads are always 0.

MFR_SLOPE_TRIM4 (E0h)

This register is used to calibrate the V_{OUT} offset caused by the slope compensation and V_{OUT} ripple.

Command	MFR_SLOPE_TRIM4																
Format	Unsigned binary																
Bit	15	14	13	12	11	10	9	8	7	6	5	4	3	2	1	0	
Access	r/w	r/w	r/w	r/w	r/w	r/w	r/w	r/w	r/w	r/w	r/w	r/w	r/w	r/w	r/w	r/w	
Function	x	x	x	x	x	x	x						x				

Bits	Bit Name	Description
15:10	RESERVED	Unused. X indicates that writes are ignored and reads are always 0.
9:5	RESERVED	Unused. X indicates that writes are ignored and reads are always 0.
4:0	RESERVED	Unused. X indicates that writes are ignored and reads are always 0.

MFR_VR_CONFIG1 (E1h)

This register sets the main functions of the controller.

Command	MFR_VR_CONFIG1															
Format	Unsigned binary															
Bit	15	14	13	12	11	10	9	8	7	6	5	4	3	2	1	0
Access	r/w	r/w	r/w	r/w	r/w	r/w	r/w	r/w	r/w	r/w	r/w	r/w	r/w	r/w	r/w	r/w
Function													0	PHASE_CNT		

Bits	Bit Name	Description
15	DC_LOOP_EN_PS2	Enable bit of the DC loop for DCM. 0: disable 1: enable
14	DC_LOOP_EN	Enable bit of the DC loop for CCM. 0: disable 1: enable
13	PSI_SEL	PSI controlling mode selector. 0: controlled by PSI 1: controlled by PMBus command (bit[12:11] of this register)
12:11	PSI_PMBUS	PSI command via PMBus. 00: full-phase CCM 01: 1-phase CCM 1x: 1-phase DCM
10	RESERVED	Unused. X indicates that writes are ignored and reads are always 0.
9	PS2_TON_REDUCE_EN	Enable bit for reducing PWM on-time to 3/4 of its normal value at PS2. 0: disable 1: enable
8	PMBUS_PSI_BYPASS_EN	Enable bit for bypassing the PSI command. When APS is enabled, set this bit to ignore the PSI command from PSI or the PMBus. 0: disable 1: enable
7	CB_EN	Enable bit for current balance loop. 0: disable 1: enable
6	OSR_EN	Enable bit for overshoot reduction. 0: disable 1: enable

5	APS_EN	Enable bit for auto-phase shedding. 0: disable 1: enable																				
4	VID_CTRL_MODE	Output voltage controlling mode. 0: output voltage is controlled via PWM-VID 1: output voltage is controlled via the PMBus																				
3	RESERVED	Fixed to 0.																				
2:0	PHASE_CNT	Phase number setting for full-phase mode. <table border="1" style="margin-left: auto; margin-right: auto;"> <thead> <tr> <th>PHASE_CNT</th> <th>Mode</th> <th>PHASE_CNT</th> <th>Mode</th> </tr> </thead> <tbody> <tr> <td>000</td> <td>1-phase DCM</td> <td>100</td> <td>4 phases</td> </tr> <tr> <td>001</td> <td>1-phase CCM</td> <td>101</td> <td>Forbidden</td> </tr> <tr> <td>010</td> <td>2 phases</td> <td>110</td> <td>Forbidden</td> </tr> <tr> <td>011</td> <td>3 phases</td> <td>111</td> <td>Forbidden</td> </tr> </tbody> </table>	PHASE_CNT	Mode	PHASE_CNT	Mode	000	1-phase DCM	100	4 phases	001	1-phase CCM	101	Forbidden	010	2 phases	110	Forbidden	011	3 phases	111	Forbidden
PHASE_CNT	Mode	PHASE_CNT	Mode																			
000	1-phase DCM	100	4 phases																			
001	1-phase CCM	101	Forbidden																			
010	2 phases	110	Forbidden																			
011	3 phases	111	Forbidden																			

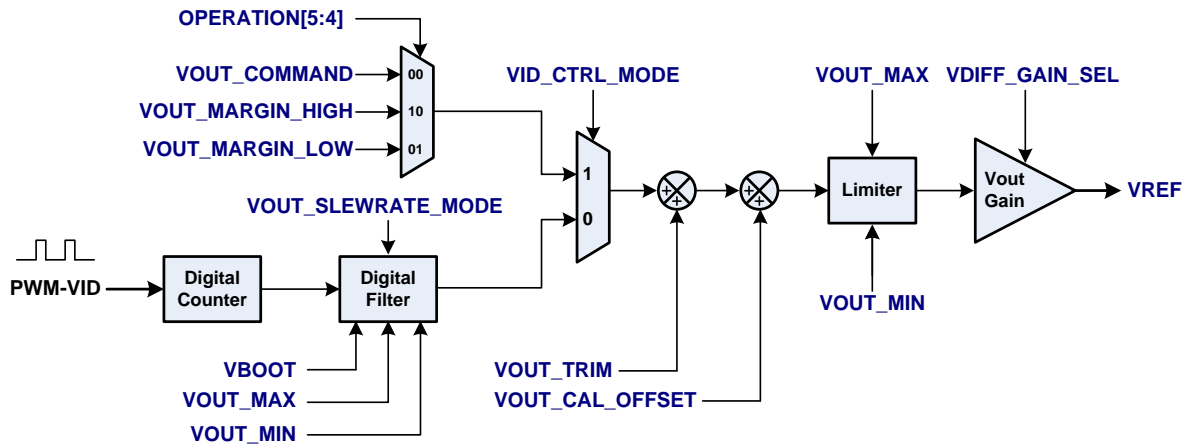

Figure 20: Conceptual View of how Output Voltage Related Commands are Applied

MFR_VR_CONFIG2 (E2h)

This register sets the main functions of the controller.

Command	MFR_VR_CONFIG2							
Format	Unsigned binary							
Bit	7	6	5	4	3	2	1	0
Access	r/w	r/w	r/w	r/w	r/w	r/w	r/w	r/w
Function	x	x	x	x				

Bits	Bit Name	Description
7:6	RESERVED	Unused. X indicates that writes are ignored and reads are always 0.
5	RESERVED	Fixed to 0.
4	RESERVED	Fixed to 0.
3	LOW_PWR_EN	Enable bit for low-power mode. Low-power mode is when EN is low and the controller disables some internal circuits to save power. PMBus communication is also disabled in low-power mode. 0: disable 1: enable

2	EN_SD_MODE	<p>Shutdown mode via EN.</p> <p>0: immediate shutdown (all PWMs are set to tri-state) 1: soft shutdown (output voltage falls to zero with a boot-up slew rate)</p> <p>If LOW_PWR_EN = 1, only immediate shutdown is available.</p>
1	DLY_CLK_SEL	<p>Delay time clock selector for TON_DELAY and TOFF_DELAY.</p> <p>0: 20µs/LSB 1: 50µs/LSB</p>
0	VOUT_SLEWRATE_MODE	<p>Output voltage (boot-up, shutdown, and DVID) slewing mode selector for PWM-VID mode.</p> <p>0: linear mode 1: R-C filter mode</p> <p>In PMBus override mode, the slew rate is always linear.</p>

MFR_APS_LEVEL1 (E3h)

This register sets the output current threshold for phase dropping when APS is enabled.

Command	MFR_APS_LEVEL1															
Format	Unsigned binary															
Bit	15	14	13	12	11	10	9	8	7	6	5	4	3	2	1	0
Access	r/w	r/w	r/w	r/w	r/w	r/w	r/w	r/w	r/w	r/w	r/w	r/w	r/w	r/w	r/w	r/w
Function	DROP_LEVEL_1P								DROP_LEVEL_DCM							

Bits	Bit Name	Description
15:8	DROP_LEVEL_1P	<p>Output current threshold for dropping to 1-phase CCM status.</p> <p>1A/LSB (TOTAL_CURRENT_RESOLUTION = 0) 2A/LSB (TOTAL_CURRENT_RESOLUTION = 1)</p>
7:0	DROP_LEVEL_DCM	<p>Output current threshold for dropping to the 1-phase DCM status.</p> <p>1A/LSB (TOTAL_CURRENT_RESOLUTION = 0) 2A/LSB (TOTAL_CURRENT_RESOLUTION = 1)</p>

MFR_APS_LEVEL2 (E4h)

This register sets the output current threshold for phase dropping when APS is enabled.

Command	MFR_APS_LEVEL2															
Format	Unsigned binary															
Bit	15	14	13	12	11	10	9	8	7	6	5	4	3	2	1	0
Access	r/w	r/w	r/w	r/w	r/w	r/w	r/w	r/w	r/w	r/w	r/w	r/w	r/w	r/w	r/w	r/w
Function	DROP_LEVEL_3P								DROP_LEVEL_2P							

Bits	Bit Name	Description
15:8	DROP_LEVEL_3P	<p>Output current threshold for dropping to 3-phase status.</p> <p>1A/LSB (TOTAL_CURRENT_RESOLUTION = 0) 2A/LSB (TOTAL_CURRENT_RESOLUTION = 1)</p>
7:0	DROP_LEVEL_2P	<p>Output current threshold for dropping to 2-phase status.</p> <p>1A/LSB (TOTAL_CURRENT_RESOLUTION = 0) 2A/LSB (TOTAL_CURRENT_RESOLUTION = 1)</p>

MFR_APS_LEVEL3 (E5h)

This register sets the output current threshold for phase dropping when APS is enabled.

Command	MFR_APS_LEVEL3															
Format	Unsigned binary															
Bit	15	14	13	12	11	10	9	8	7	6	5	4	3	2	1	0
Access	r/w	r/w	r/w	r/w	r/w	r/w	r/w	r/w	r/w	r/w	r/w	r/w	r/w	r/w	r/w	r/w
Function	1	1	1	1	1	1	1	1	1	1	1	1	1	1	1	1

Bits	Bit Name	Description
15:8	RESERVED	Fixed to 11111111.
7:0	RESERVED	Fixed to 11111111.

MFR_APS_LEVEL4 (E6h)

This register sets the output current threshold for phase dropping when APS is enabled.

Command	MFR_APS_LEVEL4															
Format	Unsigned binary															
Bit	15	14	13	12	11	10	9	8	7	6	5	4	3	2	1	0
Access	r/w	r/w	r/w	r/w	r/w	r/w	r/w	r/w	r/w	r/w	r/w	r/w	r/w	r/w	r/w	r/w
Function	1	1	1	1	1	1	1	1	1	1	1	1	1	1	1	1

Bits	Bit Name	Description
15:8	RESERVED	Fixed to 11111111.
7:0	RESERVED	Fixed to 11111111.

MFR_APS_LEVEL5 (E7h)

This register sets the output current threshold for phase dropping when APS is enabled.

Command	MFR_APS_LEVEL6															
Format	Unsigned binary															
Bit	15	14	13	12	11	10	9	8	7	6	5	4	3	2	1	0
Access	r/w	r/w	r/w	r/w	r/w	r/w	r/w	r/w	r/w	r/w	r/w	r/w	r/w	r/w	r/w	r/w
Function	1	1	1	1	1	1	1	1	1	1	1	1	1	1	1	1

Bits	Bit Name	Description
15:8	RESERVED	Fixed to 11111111.
7:0	RESERVED	Fixed to 11111111.

MFR_APS_HYS (E8h)

This register sets the output current hysteresis threshold for APS.

Command	MFR_APS_HYS							
Format	Unsigned binary							
Bit	7	6	5	4	3	2	1	0
Access	r/w	r/w	r/w	r/w	r/w	r/w	r/w	r/w
Function	HYS_APS							

Bits	Bit Name	Description
7:0	HYS_APS	Hysteresis of output current threshold for APS function. 1A/LSB (TOTAL_CURRENT_RESOLUTION = 0) 2A/LSB (TOTAL_CURRENT_RESOLUTION = 1)

MFR_TSNS_OT_SET (E9h)

This register sets the OTP function via TSNS.

Command	MFR_TSNS_OT_SET															
Format	Unsigned binary															
Bit	15	14	13	12	11	10	9	8	7	6	5	4	3	2	1	0
Access	r/w	r/w	r/w	r/w	r/w	r/w	r/w	r/w	r/w	r/w	r/w	r/w	r/w	r/w	r/w	r/w
Function	TSNS_OTP_HYS								TSNS_OTP_THRE							

Bits	Bit Name	Description
15	TSNS_OTP_EN	Enable bit for OTP via TSNS. 0: disable 1: enable
14	TSNS_OTP_MODE	Mode selector for OTP via TSNS. 0: hiccup mode 1: latch mode
13:8	TSNS_OTP_HYS	Hysteresis for exiting OTP via TSNS in hiccup mode. $TSNS_OTP_HYS = \frac{256 \times V_{TSNS_HYS}}{1.6}$ Where V_{TSNS_HYS} is the voltage hysteresis of TSNS for TSNS OTP.
7:0	TSNS_OTP_THRE	Threshold for triggering OTP via TSNS. $TSNS_OTP_THRE = \frac{256 \times V_{TSNS_THRE}}{1.6}$ Where V_{TSNS_THRE} is the voltage threshold of TSNS for OTP.

MFR_VTEMP_OT_SET (EAh)

This register sets the OTP function via VTEMP.

Command	MFR_VTEMP_OT_SET															
Format	Unsigned binary															
Bit	15	14	13	12	11	10	9	8	7	6	5	4	3	2	1	0
Access	r/w	r/w	r/w	r/w	r/w	r/w	r/w	r/w	r/w	r/w	r/w	r/w	r/w	r/w	r/w	r/w
Function	VTEMP_OTP_THRE								VTEMP_OTP_HYS							

Bits	Bit Name	Description
15:8	VTEMP_OTP_THRE	Threshold for OTP via VTEMP. 1°C/LSB.
7	VTEMP_OTP_MODE	Mode selector for OTP via VTEMP. 0: hiccup mode 1: latch mode
6:0	VTEMP_OTP_HYS	Hysteresis for exiting OTP via VTEMP in hiccup mode. 1°C/LSB.

MFR_OCP_TOTAL (ECh)

This register sets the total output over-current protection (OCP). Total OCP is not active during soft start.

Command	MFR_OCP_TOTAL																
Format	Unsigned binary																
Bit	15	14	13	12	11	10	9	8	7	6	5	4	3	2	1	0	
Access	r/w	r/w	r/w	r/w	r/w	r/w	r/w	r/w	r/w	r/w	r/w	r/w	r/w	r/w	r/w	r/w	
Function	x			OCP_DEGLITCH_TIME						OCP_THRE							

Bits	Bit Name	Description
15	RESERVED	Unused. X indicates that writes are ignored and reads are always 0.
14:13	OCP_MODE	Total OCP action mode selector. 00: no action 01: latch off 10: hiccup 11: retry six times
12:7	OCP_DEGLITCH_TIME	Deglintch time for total OCP. When the protection condition lasts for this deglintch time, the VR shuts down. 100µs/LSB.
6:0	OCP_THRE	Threshold of total OCP. 1A/LSB (TOTAL_CURRENT_RESOLUTION = 0) 2A/LSB (TOTAL_CURRENT_RESOLUTION = 1)

MFR_OCP_PHASE (EDh)

This register sets the phase valley current limit. When a certain phase's inductor current is greater than this threshold, its PWM cannot turn high.

Command	MFR_OCP_PHASE							
Format	Unsigned binary							
Bit	7	6	5	4	3	2	1	0
Access	r/w	r/w	r/w	r/w	r/w	r/w	r/w	r/w
Function	x			PHASE_CUR_LIMIT				

Bits	Bit Name	Description
7	RESERVED	Unused. X indicates that writes are ignored and reads are always 0.
6:0	PHASE_CUR_LIMIT	Per-phase valley current limit. 1A/LSB (PHASE_CURRENT_RESOLUTION = 0) 2A/LSB (PHASE_CURRENT_RESOLUTION = 1)

MFR_OVP_UVP_SET (EEh)

This register sets V_{OUT} OVP and UVP. The OVP2 and UVP2 level is selected by bit[2:0] of register MFR_OVUV_SEL (2Ch). OVP2 and UVP are not active during the soft-start process.

Command	MFR_OVP_UVP_SET																
Format	Unsigned binary																
Bit	15	14	13	12	11	10	9	8	7	6	5	4	3	2	1	0	
Access	r/w	r/w	r/w	r/w	r/w	r/w	r/w	r/w	r/w	r/w	r/w	r/w	r/w	r/w	r/w	r/w	
Function				OVP2_DEGLITCH_TIME						UVP_DEGLITCH_TIME							

Bits	Bit Name	Description
15:13	OVP2_MODE	OVP mode selector. 000: no action 010: latch off 100: hiccup 110: retry six times 111: retry three times
12:8	OVP2_DEGLITCH_TIME	Deglitch time for OVP. When the protection condition lasts for this deglitch time, the VR shuts down. 100ns/LSB.
7:6	UVP_MODE	UVP mode selector. 00: no action 01: latch off 10: hiccup 11: retry six times
5:0	UVP_DEGLITCH_TIME	Deglitch time for UVP. When the protection condition lasts for this deglitch time, the VR shuts down. 20µs/LSB.

MFR_FAULTS1 (F8h)

This register returns the faults of the present protection. These bits are in latch mode. The CLEAR_FAULTS command can reset these bits.

Command	MFR_FAULTS1															
Format	Unsigned binary															
Bit	15	14	13	12	11	10	9	8	7	6	5	4	3	2	1	0
Access	r	r	r	r	r	r	r	r	r	r	r	r	r	r	r	r
Function	x	x	x		CS_FAULT_TRG			x								

Bits	Bit Name	Description
15:13	RESERVED	Unused. X indicates that writes are ignored and reads are always 0.
12	TEMP_FAULT_TRG	Flag of TEMP_FAULT protection. 0: protection not triggered by TEMP_FAULT of the Intelli-Phase 1: protection triggered by TEMP_FAULT of the Intelli-Phase
11:8	CS_FAULT_TRG	Flag for CS_FAULT triggering VR protection. 0000: protection not triggered by CS_FAULT of the Intelli-Phase 0001: protection triggered by CS1_FAULT of the Intelli-Phase 0010: protection triggered by CS2_FAULT of the Intelli-Phase 0011: protection triggered by CS3_FAULT of the Intelli-Phase 0100: protection triggered by CS4_FAULT of the Intelli-Phase
7	RESERVED	Unused. X indicates that writes are ignored and reads are always 0.
6	VIN_OV_FLAG	Flag of input OVP.
5	VIN_UVLO_FLAG	Flag of input UVP.
4	VTEMP_OTP_FLAG	Flag of OTP from VTEMP.
3	TSNS_OTP_FLAG	Flag of OTP from TSNS.
2	OVP_FLAG	Flag of output OVP.
1	UVP_FLAG	Flag of output UVP.
0	OCP_FLAG	Flag of output OCP.

MFR_FAULTS2 (F9h)

This register returns the faults of the present protection. These bits are in latch mode. The CLEAR_FAULTS command can reset these bits.

Command	MFR_FAULTS2															
Format	Unsigned binary															
Bit	15	14	13	12	11	10	9	8	7	6	5	4	3	2	1	0
Access	r	r	r	r	r	r	r	r	r	r	r	r	r	r	r	r
Function	PWM1_FAULTS				PWM2_FAULTS				PWM3_FAULTS				PWM4_FAULTS			

Bits	Bit Name	Description
15:12	PWM1_FAULTS	Intelli-Phase fault type indication of phase 1. 0000: no fault 0001: VIN-SW short 0010: current-limit protection 0100: over-temperature protection 1000: SW-PGND short protection
11:8	PWM2_FAULTS	Intelli-Phase fault type indication of phase 2. Same types as bit[15:12].
7:4	PWM3_FAULTS	Intelli-Phase fault type indication of phase 3. Same types as bit[15:12].
3:0	PWM4_FAULTS	Intelli-Phase fault type indication of phase 4. Same types as bit[15:12].

MFR_FAULTS3 (FAh)

This register returns the faults of the present protection. These bits are in latch mode. The CLEAR_FAULTS command can reset these bits.

Command	MFR_FAULTS3															
Format	Unsigned binary															
Bit	15	14	13	12	11	10	9	8	7	6	5	4	3	2	1	0
Access	r	r	r	r	r	r	r	r	r	r	r	r	r	r	r	r
Function	x				x				x				x			

Bits	Bit Name	Description
15:12	RESERVED	Unused. X indicates that writes are ignored and reads are always 0.
11:8	RESERVED	Unused. X indicates that writes are ignored and reads are always 0.
7:4	RESERVED	Unused. X indicates that writes are ignored and reads are always 0.
3:0	RESERVED	Unused. X indicates that writes are ignored and reads are always 0.

MFR_FAULTS4 (FBh)

This register returns the faults of the present protection. These bits are in latch mode. The CLEAR_FAULTS command can reset these bits.

Command	MFR_FAULTS4															
Format	Unsigned binary															
Bit	15	14	13	12	11	10	9	8	7	6	5	4	3	2	1	0
Access	r	r	r	r	r	r	r	r	r	r	r	r	r	r	r	r
Function	x				x				x	x	x	x	x	x	x	x

Bits	Bit Name	Description
15:12	RESERVED	Unused. X indicates that writes are ignored and reads are always 0.
11:8	RESERVED	Unused. X indicates that writes are ignored and reads are always 0.
7:0	RESERVED	Unused. X indicates that writes are ignored and reads are always 0.

CLEAR_EEPROM_FAULTS (FFh)

This command is used to clear the EEPROM fault. This command is write only. There is no data byte for this command.

PAGE 29 REGISTER MAP

MFR_LAST_FAULTS1 (FBh)

This register returns the faults of the last protection. To clear the fault bits, 0x0000 can be written to this register. Then wait for 5ms.

Command	MFR_LAST_FAULTS1															
Format	Unsigned binary															
Bit	15	14	13	12	11	10	9	8	7	6	5	4	3	2	1	0
Access	r/w	r/w	r/w	r/w	r/w	r/w	r/w	r/w	r/w	r/w	r/w	r/w	r/w	r/w	r/w	r/w
Function	x	x	x		CS_FAULT_TRG			x								

Bits	Bit Name	Description
15:13	RESERVED	Unused. X indicates that writes are ignored and reads are always 0.
12	TEMP_FAULT_TRG	Flag of TEMP_FAULT protection. 0: protection not triggered by TEMP_FAULT of the Intelli-Phase 1: protection triggered by TEMP_FAULT of the Intelli-Phase
11:8	CS_FAULT_TRG	Flag for CS_FAULT triggering VR protection. 0000: protection is not triggered by CS_FAULT of the Intelli-Phase 0001: protection is triggered by CS1_FAULT of the Intelli-Phase 0010: protection is triggered by CS2_FAULT of the Intelli-Phase 0011: protection is triggered by CS3_FAULT of the Intelli-Phase 0100: protection is triggered by CS4_FAULT of the Intelli-Phase
7	RESERVED	Unused. X indicates that writes are ignored and reads are always 0.
6	VIN_OV_FLAG	Flag of input OVP.
5	VIN_UVLO_FLAG	Flag of input UVP.
4	VTEMP_OTP_FLAG	Flag of OTP from VTEMP.
3	TSNS_OTP_FLAG	Flag of OTP from TSNS.
2	OVP_FLAG	Flag of output OVP.
1	UVP_FLAG	Flag of output UVP.
0	OCP_FLAG	Flag of output OCP.

MFR_LAST_FAULTS2 (FCh)

This register returns the faults of the last protection. To clear the fault bits, 0x0000 can be written to this register. Then wait for 5ms.

Command	MFR_LAST_FAULTS2															
Format	Unsigned binary															
Bit	15	14	13	12	11	10	9	8	7	6	5	4	3	2	1	0
Access	r/w	r/w	r/w	r/w	r/w	r/w	r/w	r/w	r/w	r/w	r/w	r/w	r/w	r/w	r/w	r/w
Function	PWM1_FAULTS				PWM2_FAULTS				PWM3_FAULTS				PWM4_FAULTS			

Bits	Bit Name	Description
15:12	PWM1_FAULTS	Intelli-Phase fault type indication of phase 1. 0000: no fault 0001: VIN-SW short 0010: current-limit protection 0100: over-temperature protection 1000: SW-PGND short protection
11:8	PWM2_FAULTS	Intelli-Phase fault type indication of phase 2. Same types as bit[15:12].
7:4	PWM3_FAULTS	Intelli-Phase fault type indication of phase 3. Same types as bit[15:12].
3:0	PWM4_FAULTS	Intelli-Phase fault type indication of phase 4. Same types as bit[15:12].

MFR_LAST_FAULTS3 (FDh)

This register returns the faults of the last protection. To clear the fault bits, 0x0000 can be written to this register. Then wait for 5ms.

Command	MFR_LAST_FAULTS3															
Format	Unsigned binary															
Bit	15	14	13	12	11	10	9	8	7	6	5	4	3	2	1	0
Access	r/w	r/w	r/w	r/w	r/w	r/w	r/w	r/w	r/w	r/w	r/w	r/w	r/w	r/w	r/w	r/w
Function	x				x				x				x			

Bits	Bit Name	Description
15:12	RESERVED	Unused. X indicates that writes are ignored and reads are always 0.
11:8	RESERVED	Unused. X indicates that writes are ignored and reads are always 0.
7:4	RESERVED	Unused. X indicates that writes are ignored and reads are always 0.
3:0	RESERVED	Unused. X indicates that writes are ignored and reads are always 0.

MFR_LAST_FAULTS4 (FEh)

This register returns the faults of the last protection. To clear the fault bits, 0x0000 can be written to this register. Then wait for 5ms.

Command	MFR_LAST_FAULTS4															
Format	Unsigned binary															
Bit	15	14	13	12	11	10	9	8	7	6	5	4	3	2	1	0
Access	r/w	r/w	r/w	r/w	r/w	r/w	r/w	r/w	r/w	r/w	r/w	r/w	r/w	r/w	r/w	r/w
Function	x				x				x	x	x	x	x	x	x	x

Bits	Bit Name	Description
15:12	RESERVED	Unused. X indicates that writes are ignored and reads are always 0.
11:8	RESERVED	Unused. X indicates that writes are ignored and reads are always 0.
7:0	RESERVED	Unused. X indicates that writes are ignored and reads are always 0.

PACKAGE INFORMATION

QFN-40 (5mmx5mm)

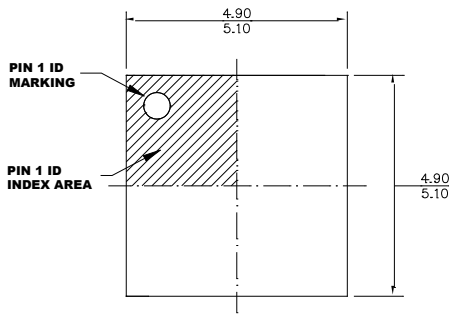

TOP VIEW

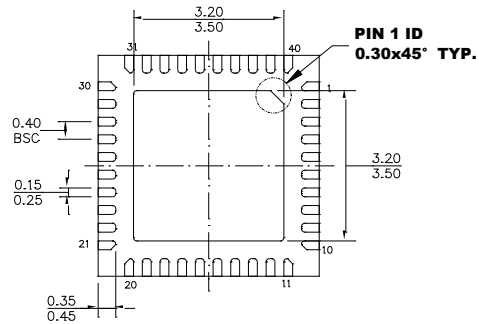

BOTTOM VIEW

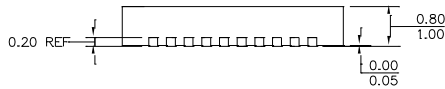

SIDE VIEW

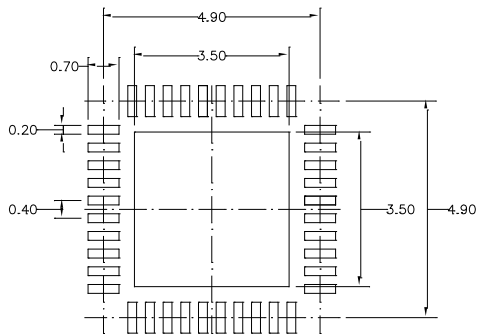

RECOMMENDED LAND PATTERN

NOTE:

- 1) ALL DIMENSIONS ARE IN MILLIMETERS.
- 2) EXPOSED PADDLE SIZE DOES NOT INCLUDE MOLD FLASH.
- 3) LEAD COPLANARITY SHALL BE 0.08 MILLIMETERS MAX.
- 4) DRAWING CONFIRMS TO JEDEC MO-220, VARIATION VHHE-1
- 5) DRAWING IS NOT TO SCALE.

REVISION HISTORY

Revision #	Revision Date	Description	Pages Updated
1.0	9/26/2018	Initial Release	-
1.01	12/21/2018	Changed Enable high leakage max value from 2.1 μ A to 2.3 μ A in Electrical Characteristics section.	6
1.02	11/14/2025	<ul style="list-style-type: none">Updated Description section to remove confidential customer name.Updated Features section to remove confidential customer name.	1
		Updated Operation section to remove confidential customer name.	13

NOTICE: The information in this document is subject to change without notice. Please contact MPS for current specifications. Users should warrant and guarantee that third party Intellectual Property rights are not infringed upon when integrating MPS products into any application. MPS will not assume any legal responsibility for any said applications.