

DESCRIPTION

The MP26075 is a linear, high performance, and high efficiency single cell Li-Ion or Li-polymer battery charger for AC adapter input in the plug-in, cradle charger applications.

The device will control the AC adapter output voltage against the battery voltage to increase energy efficiency. Additionally, MP26075 can provide very low pre-charge charge current for deep-discharged battery.

For guaranteed safe operation, MP26075 controls power up sequencing. It ramps-up AC adapter firstly to limit inrush current when the adapter plug in. Other safety feature includes battery temperature monitoring, charge time-out and fault indications, it also provides input/output over voltage protection and charge status indications.

MP26075 is available in QFN 3x3mm package.

FEATURES

- Voltage control function for the fly-back controller
- High charge efficiency
- Battery voltage options: 4.05V-4.20V.
- Low current pre-charge mode
- Controlled power-up sequencing
- Battery temperature monitoring
- Charge status indication
- Auto-Recharge
- Fault indications
- Internal timer
- Input/output OVP
- Over temperature protection

APPLICATIONS

- Cell Phones
- Portable Music Players
- Smart Phones
- PDA
- Digital Cameras

For MPS green status, please visit MPS website under Quality Assurance. "MPS" and "The Future of Analog IC Technology" are Registered Trademarks of Monolithic Power Systems, Inc.

TYPICAL APPLICATION

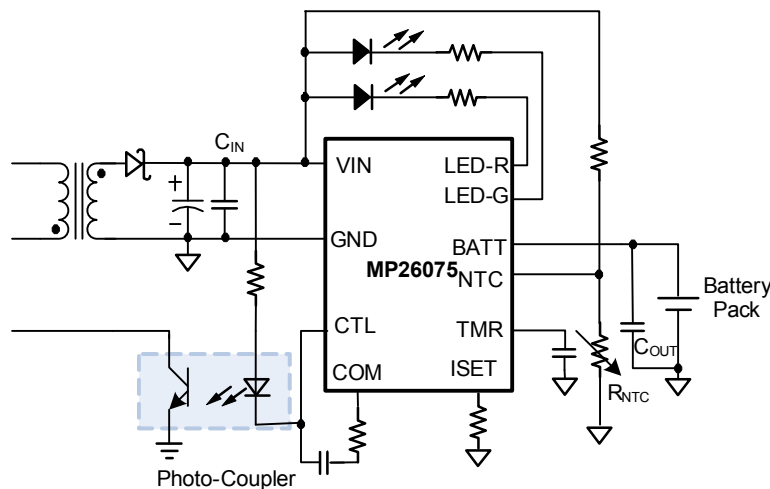

ORDERING INFORMATION

Part Number*	Battery Voltage	Package	Top Marking	Free Air Temperature (T _A)
MP26075EQ	4.20V	QFN10 (3x3mm)	8N	-20°C to +85°C
MP26075EQ-41**	4.10V		ACC	

* For Tape & Reel, add suffix -Z (e.g. MP26075EQ-Z);
 For RoHS Compliant Packaging, add suffix -LF (e.g. MP26075EQ-LF-Z)

** MP26075 has several options with different battery voltages.
 Please refer to the ordering information list. And Contact factory for other battery voltages.

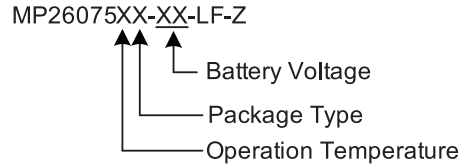

PACKAGE REFERENCE

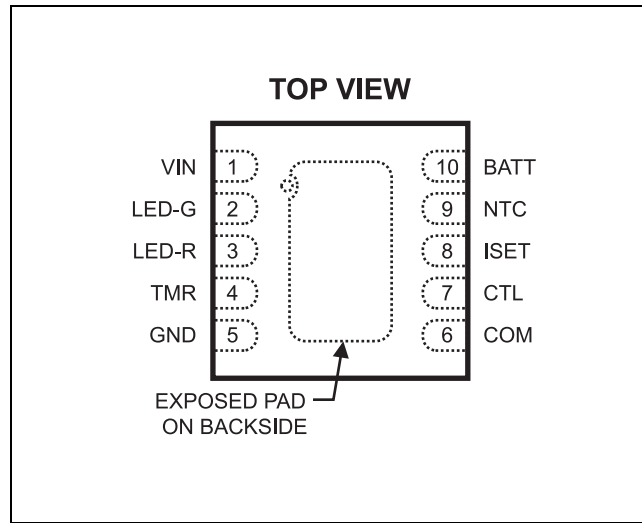

ABSOLUTE MAXIMUM RATINGS ⁽¹⁾

VIN to GND	-0.3V to +28V
LED-R and LED-G Maximum Sink Current	20mA
All Other Pins to GND	-0.3V to +6.5V
Continuous Power Dissipation (T _A = +25°C)	
.....	2.5W
Junction Temperature	140°C
Lead Temperature	260°C
Storage Temperature.....	-65°C to +150°C

Recommended Operating Conditions ⁽³⁾

Supply Voltage V _{IN}	2.2V to 6.3V
Maximum Junction Temp. (T _J).....	+125°C

Thermal Resistance ⁽⁴⁾	θ_{JA}	θ_{JC}
3x3 QFN10	50	12... °C/W

Notes:

- 1) Exceeding these ratings may damage the device.
- 2) The maximum allowable power dissipation is a function of the maximum junction temperature T_J(MAX), the junction-to-ambient thermal resistance θ_{JA} , and the ambient temperature T_A. The maximum allowable continuous power dissipation at any ambient temperature is calculated by P_D(MAX)=(T_J(MAX)-T_A)/ θ_{JA} . Exceeding the maximum allowable power dissipation will cause excessive die temperature, and the regulator will go into thermal shutdown. Internal thermal shutdown circuitry protects the device from permanent damage.
- 3) The device is not guaranteed to function outside of its operating conditions.
- 4) Measured on JESD51-7 4-layer board.

ELECTRICAL CHARACTERISTICS ⁽⁵⁾
 $V_{IN}=5V$ (fast charge state not included), $T_A=-20^{\circ}C$ to $+85^{\circ}C$, Typical values are at $T_A=+25^{\circ}C$, unless otherwise noted.

Parameter	Symbol	Condition	Min	Typ	Max	Units	
Battery Voltage Regulation	V_{BATT}	$T_A=-5^{\circ}C$ to $+75^{\circ}C$ $I_{BATT}=0A$	4.20V	4.16	4.20	4.24	V
			4.15V	4.11	4.15	4.19	
			4.10V	4.06	4.10	4.14	
			4.05V	4.01	4.05	4.09	
Constant Current Regulation	I_{CHG}	$V_{IN}=5V, V_{BATT}=3.8V,$ $R_{CHG}=1.7k$	0.85	1	1.2	A	
Constant Current Variation		$V_{IN}=5V, V_{BATT}=3.8V,$ $T_A=0^{\circ}C$ to $85^{\circ}C$ $R_{CHG}=1.7k\sim 8.0k$	85	100	120	%	
Trickle current regulation	I_{CHG}	$V_{IN}=5V, V_{BATT}=2.5V$ $R_{CHG}=1.7k$	85	100	120	mA	
Input voltage regulation	V_{IN}	When $V_{BATT}<3V$		5		V	
		When $V_{BATT}>3V,$ $I_{CHG}>100mA$		$V_{BATT}+0.5V$		V	
		When $V_{BATT}>3V,$ $I_{CHG}<100mA$		5		V	
$V_{IN}-V_{BATT}$ during fast charge state		$V_{BATT}=3.8V$		500		mV	
Input UVLO threshold	V_{IN}		1.5	2.0	2.5	V	
UVLO hysteresis				200		mV	
Input OVP threshold	V_{IN}		6.1	6.3	6.5	V	
Input OVP hysteresis				500		mV	
Output over voltage threshold	$V_{BATT}=4.2V$	$V_{BATT-OVP}$	$V_{IN}=4.85V$	4.25	4.35	4.5	V
	$V_{BATT}=4.1V$	$V_{BATT-OVP}$	$V_{IN}=4.85V$	4.15	4.25	4.4	V
Battery Pre-charge Range	$V_{pre-Charge}$	$V_{IN}=5V$	0		2.1	V	
Battery Trickle-charge Threshold	$V_{TC-Charge}$	$V_{IN}=5V$		2.1		V	
Battery Fast-charge Threshold	$V_{Fast-Charge}$	$V_{IN}=5V$		3		V	
LED RED sink current		PIN voltage=0.2V	8			mA	
LED GREE sink current		PIN voltage=0.2V	8			mA	
BATT reverse current to BATT PIN		$V_{IN} = 0$ or floating			2	μA	
Recharge Voltage attenuate from V_{BATT}				8		% V_{BATT}	
NTC High Threshold	V_{NTC_HIGH}	$V_{IN}=5V$		2.16		V	
NTC High Trip Hysteresis		$V_{IN}=5V$		78		mV	
NTC Low Threshold	V_{NTC_LOW}	$V_{IN}=5V$		0.37		V	
NTC Low Trip Hysteresis		$V_{IN}=5V$		30		mV	
Timer frequency		$C_{TMR}=0.1\mu F$	7			Hz	
Die temperature Limit ⁽⁵⁾				120		$^{\circ}C$	

Notes:

5) Guaranteed by design

PIN FUNCTIONS

Pin #	Name	Description
1	VIN	Input Supply Pin. Decoupling Capacitor is needed to prevent large voltage spikes.
2	LED-G	Open-Drain Charge status Indicator. This pin is high during charge and fault condition, is low after battery full or termination.
3	LED-R	Open-Drain Charge status Indicator. This pin is low during charge, is high after battery full or termination and fault condition.
4	TMR	Pin of the oscillator. Connect a capacitor from this pin to GND to set the oscillator cycle. Timer setting time changes according to oscillation cycle.
5	GND	GND pin.
6	COM	Compensation for VIN limits circuit.
7	CTL	CTL is used for VIN control. Connect to the cathode of photo diode of photo coupler by a resistor.
8	ISET	Connect a resistor R between ISET and GND of Battery Pack to set the charge current.
9	NTC	Battery temperature monitoring pin. Connect a resistor from this pin to VIN and connect this pin to the thermistor pin of the battery pack.
10	BATT	Charger Output terminal.

TYPICAL PERFORMANCE CHARACTERISTICS

Test with AC_IN=220V flyback, C_IN = 4.7μF, C_OUT = 10μF, I_CHG = 1000mA, unless otherwise noted.

Real Battery Charge Curve

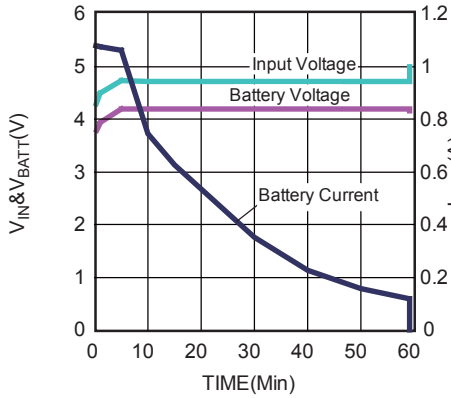

Charge Current vs Battery Voltage

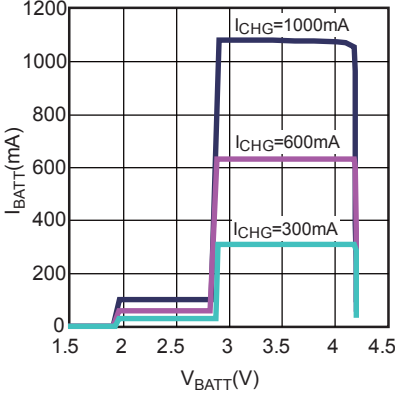

Charge Input Voltage vs Battery Voltage

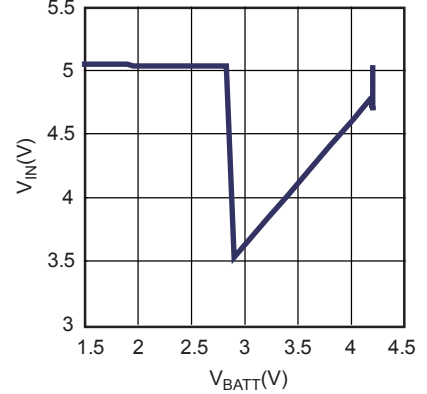

Battery Reverse Current I_BATT vs V_BATT Curve

V_IN=GND, Power Source on BATT

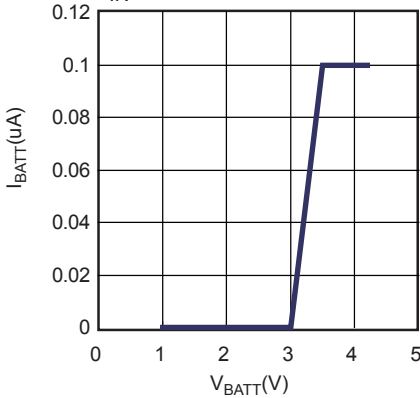

R_CHG vs. I_CHG Curve

Constant Current charge, V_BATT=3.8V

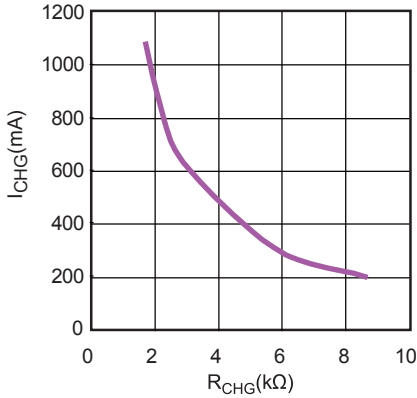

R_CHG vs. I_CHG Curve

Trickle charge, V_BATT=2.4V

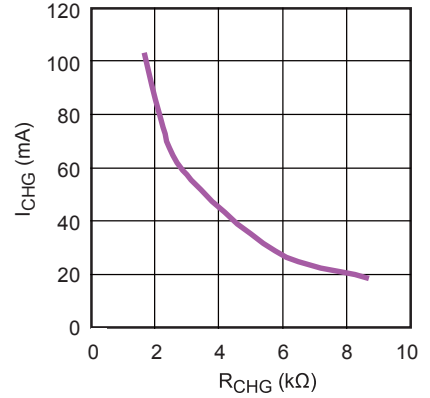

ΔV(V_IN-V_BATT) vs. JunctionTemp

Constant Current charge

V_BATT=3.8V

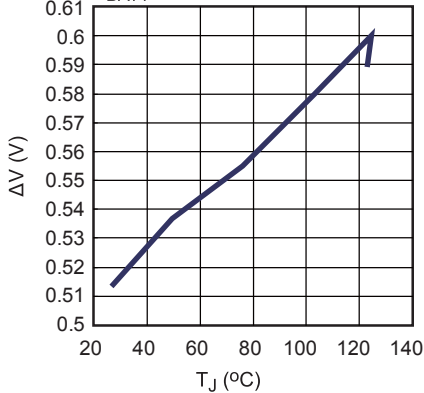

CC Charge Current vs. Temp

Constant Current charge,

V_BATT=3.8V

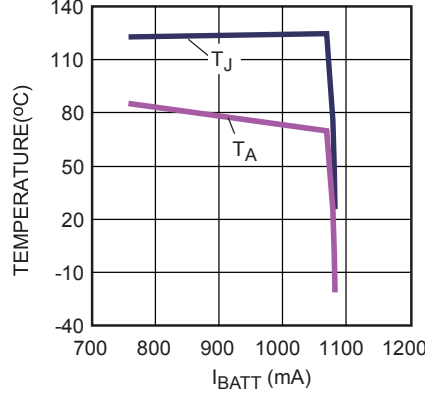

CC Charge Current vs. Temp Zoom In

The junction temperature is too high. Part enters thermal foldback mode

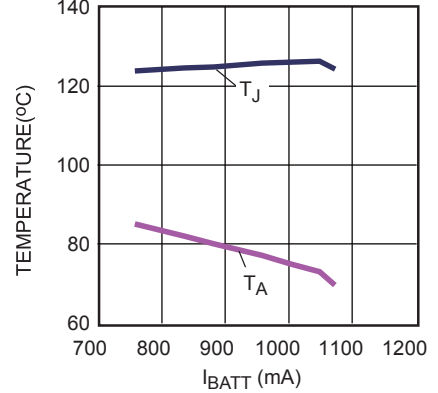

TYPICAL PERFORMANCE CHARACTERISTICS *(continued)*

Test with AC_IN=220V flyback, C_{IN_CHARGER} = 4.7μF, C_{OUT_CHARGER} = 10μF, I_{CHG} = 1000mA, unless otherwise noted.

Input Power Start Up

Real Battery, V_{BATT}=3.8V

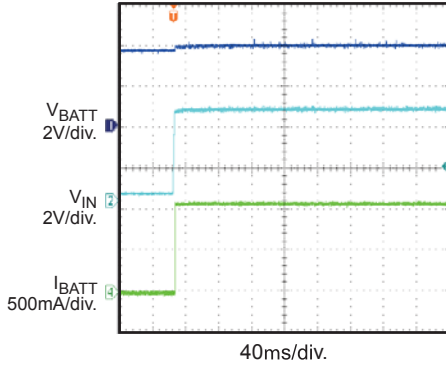

Input Power Shut Down

Real Battery, V_{BATT}=3.8V

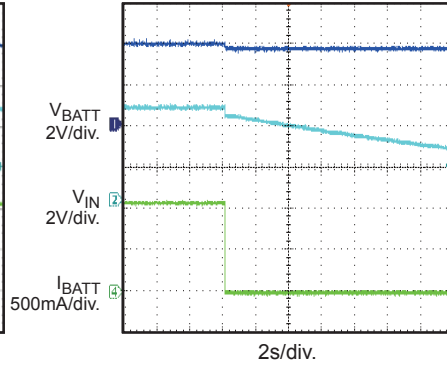

Auto Re-charge

Battery Float

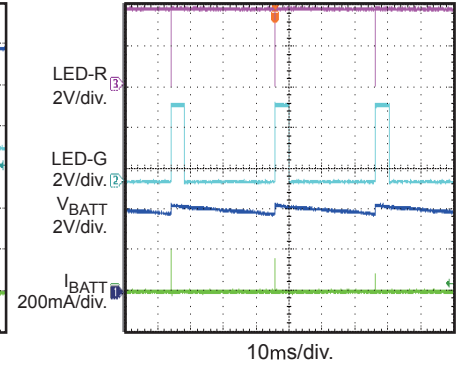

NTC Window Control

V_{BATT}=3.8V,
CV Load V_{NTC} from 0V to 2.5V

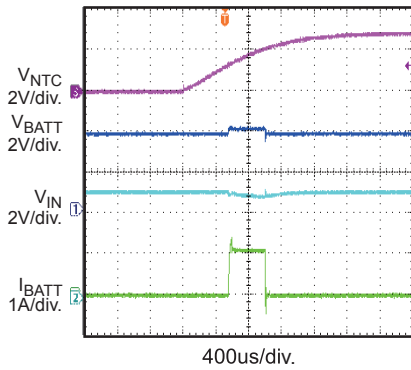

Input OVP Entry

Open flyback Loop,
V_{BATT}=3.8V, V_{IN} from 5V to 7V

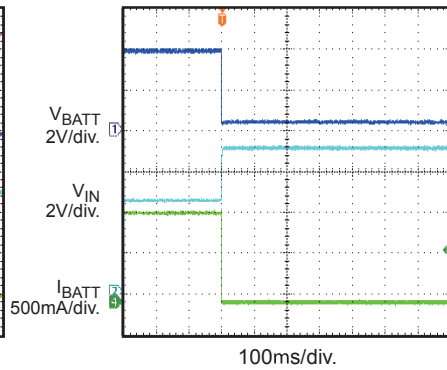

Timer Out

V_{BATT}=2.1V, C_{TMR}=100pF

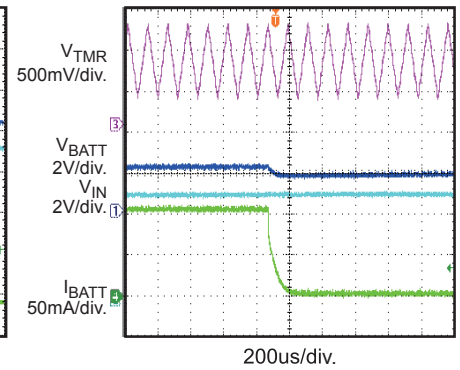

BLOCK DIAGRAM

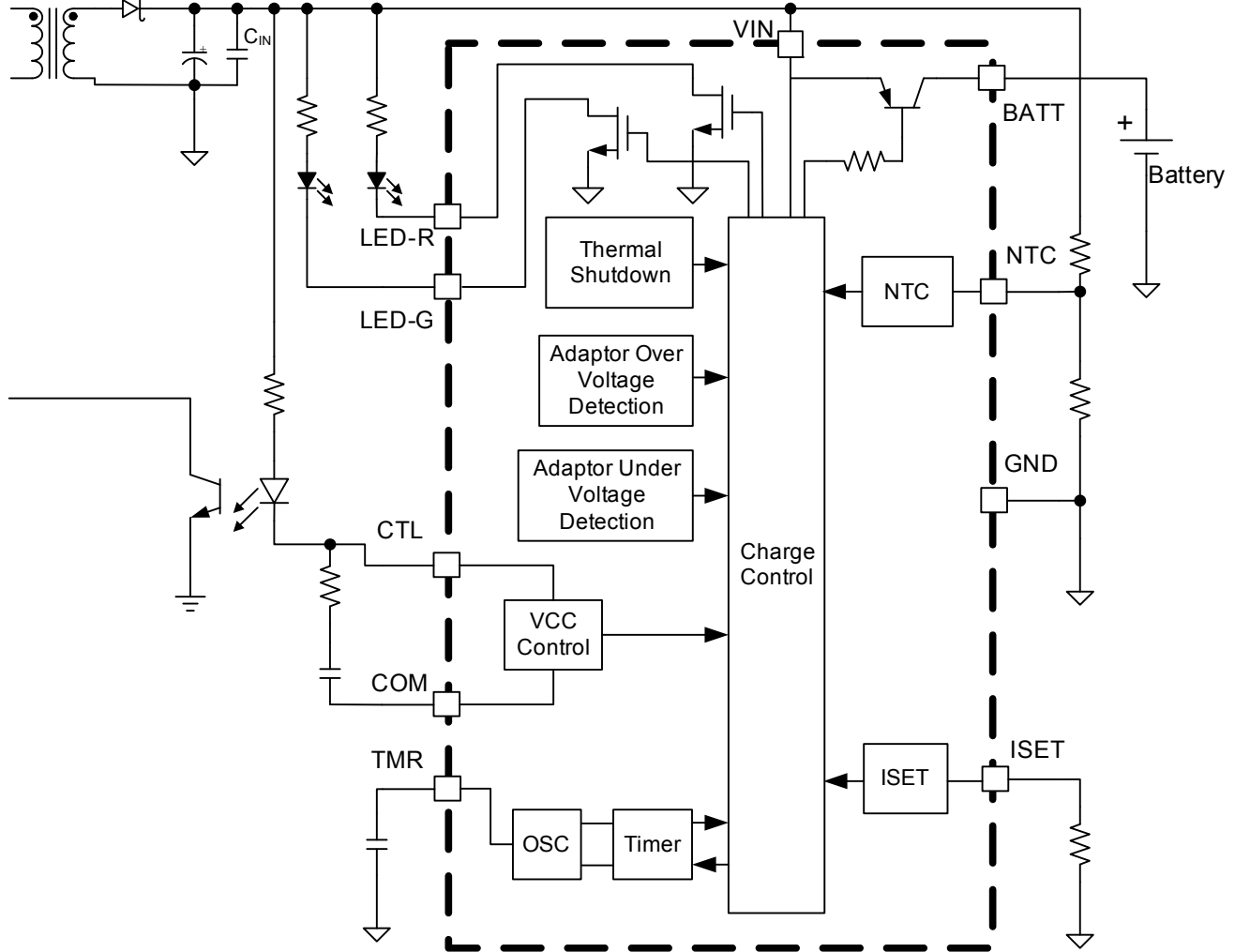

Figure 1— Function Block Diagram

OPERATION

The high-efficiency linear charger is mainly for plug-in, cradle charger applications. The device features using a photo-coupler to directly feedback the charge voltage and charge current information to the primary side. It is recommended to use with flyback controller for smooth system setup.

Figure 2 is the typical configuration for the charger with photo-coupler feedback to control the AC adapter. The voltage change of the CTL pin will be transferred to the comp pin of the AC adapter controller by the photo-coupler, which controls the conduction time of the primary side switch. The output voltage at secondary side of the transformer is then adjusted.

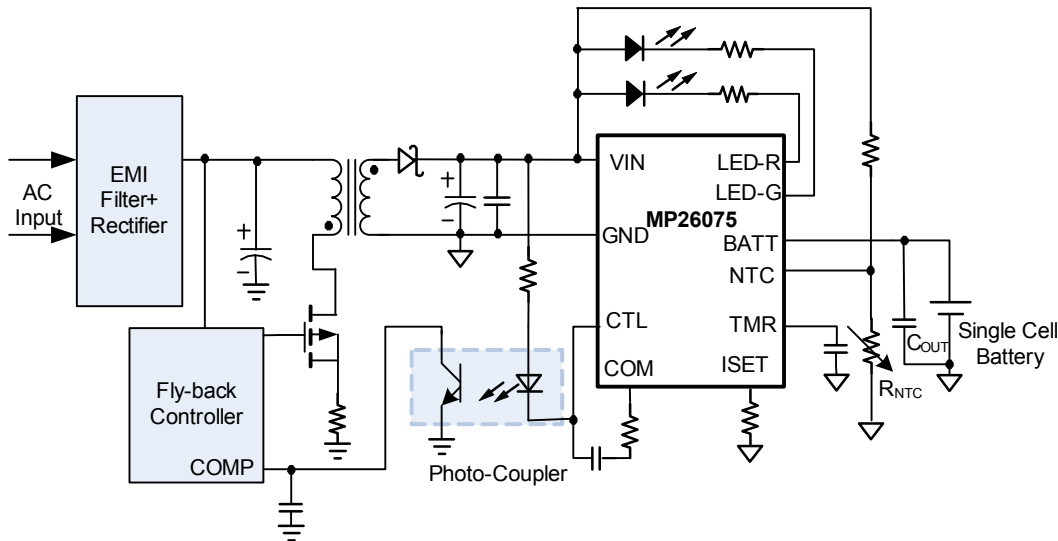

Figure 2— System Configuration

Input Voltage Range

The MP26075 has built-in input voltage surge protection as high as $\pm 28V$. The charger IC will be automatically disabled when the input voltage is lower than 2.2V or higher than 6.3V. If the input voltage is lower than the battery voltage, the IC is also disabled to prevent the battery from draining. The MP26075 includes a proprietary input reverse polarity circuit that eliminates the requirement for an external Schottky diode.

Charge Cycle (Mode Change: Precharge-> Trickle -> CC-> CV)

Figure 3 below shows the typical charge profile for the MP26075. For a fully depleted battery with a terminal voltage lower than 2.1V, the MP26075 will start with 1mA pre-charge. If the charger stays in the pre-charge mode longer than 512 cycles, LED-R and LED-G pins become high to indicate the battery fault, and the charge is terminated. And when battery voltage reaches 2.1V the MP26075 will start the trickle charge (preconditioning) at 10% of the full charge current

based on the value of R_{CHG} . If the charger stays in the trickle mode longer than 16384 cycles, LED-R and LED-G pins become high to indicate battery fault, and the charge is terminated. After the battery voltage reaches 3.0V, the charger begins charge at the constant current of the programmed value (I_{CHG}). This is referred to as the constant current (CC) mode. Once the battery voltage reaches the battery regulation voltage (e.g.4.2V), the charger will operate in the constant voltage (CV) mode until the battery is fully charged. The charge current drops during CV mode, and the battery full indication is set when the charge current reduced to 10% of the programmed constant current value (I_{CHG}), and the charge process is terminated. Recharge will start after the battery voltage is reduced to 8% of V_{BATT} . After 262144 cycles of continuous charge, if the battery is still not reaching 10% of I_{CHG}

condition, the on-chip timer will terminate the charger to prevent charging the dead battery for excessive long time and the fault condition will be flagged by floating LED-R and LED-G pins.

Charge Termination

The charge current will gradually decrease in CV mode as the battery approaches full. The battery full threshold is internally programmed to be 10% of the I_{CHG} . When the charge current reaches this threshold, the charger IC will be automatically turned off.

Automatic Recharge

Upon V_{BATT} drops to 8% of V_{BATT} , the charger will automatically restart the charge cycle until the 10% I_{CHG} condition is met again. When the input adapter is unplugged or the charger is disabled and/or terminated, the leakage current from the battery to MP26075 is less than 2 μ A.

Programming of Charge Current

The charge current (I_{CHG}) is set by a resistor (R_{CHG}) connecting from the ISET pin to GND. The relationship of the charge current and the programming resistance is established by the following formula.

$$I_{CHG} = \frac{1.23V}{R_{CHG}(k)} \times 1400(A)$$

Timer Operation

The TMR pin is used to set the internal oscillator frequency, $T=900000 \cdot CTMR$ (sec). The on-chip timer will start count down after initial power-up or every time being enabled. This timer will limit the max pre-charge time to 512 internal cycles and max trickle-charge time to 16384 internal oscillating cycles. If the charger stays in pre-charge mode for longer than 512 cycles or in trickle mode for longer than 16384 cycles, it will be terminated and a fault will be set by floating LED-R and LED-G pins. After fault reporting, the charger can be re-initiated only by recycling the power supply. If the charger successfully goes through trickle charge within the allowed time limit, it will start CC charge and then CV charge. If the total charge time exceeds 262144 cycles and the battery full has not been qualified, the charger will be terminated and a fault will also be set by floating LED-R and LED-G pins. This function prevents charging a dead battery for

prolonged duration. The timer function can be disabled by shorting TMR pin to ground.

Table1— Timer of Each Times

Item	Calculation formula
1mA charge timer	Tx512
Trickle charge timer	Tx16384
Total charge timer	Tx262144

Negative Thermal Coefficient (NTC) Thermistor

The MP26075 has a built-in NTC resistance window comparator, which allows MP26075 to sense the battery temperature via the thermistor packed internally in the battery pack to ensure a safe operating environment of the battery. A resistor with appropriate value should be connected from VIN to NTC pin and the thermistor is connected from NTC pin to GND. The voltage on NTC pin depends on the ratio of the resistor divider. When the voltage of pin NTC falls out of the NTC window range, MP26075 will stop the charge. The charger will restart if the temperature goes back into the NTC window range.

Thermal Protection

The MP26075 has proprietary thermal protection to prevent the IC from overheating. When in thermal protection mode, the average charge current will be reduced to prevent the IC from overheating. Operating in thermal protection mode will slow down the charge process. Lowering the input voltage and enhancing thermal dissipation to the environment can effectively prevent the IC from going into thermal protection mode.

Status Indication

MP26075 has two open-drain status outputs: LED-R and LED_G. Both LED-R and LED-G are used to indicate the status of the charge cycle. Table 2 describes the status of the charge cycle based on the LED-R and LED_G outputs. The LED-R and LED_G pins pull high when any fault happens.

Table 2— Charge Status Indication

LED-R	LED-G	Status
High	High	Fault/toggle
Low	High	Normal charge
High	Low	End of charge

Compensation

COM pin is used to compensation Vin control loop. Connect a Resistor and a capacitor between COM pin and CTL pin to keep system's stability. 100nF capacitor and several kilo-ohms resistor are recommended. And for specific design, please refer to application information of the primacy flyback controller.

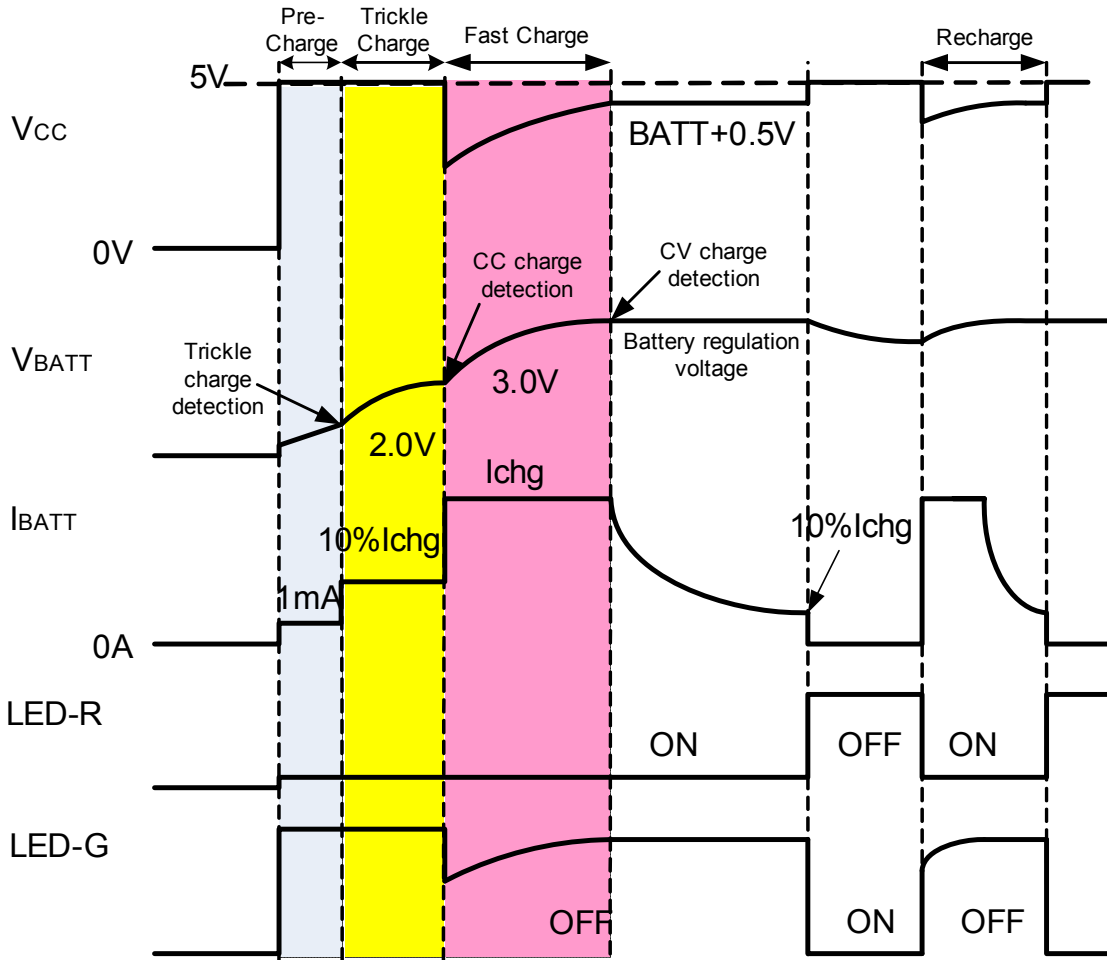

Figure 3— Typical Charge Profile

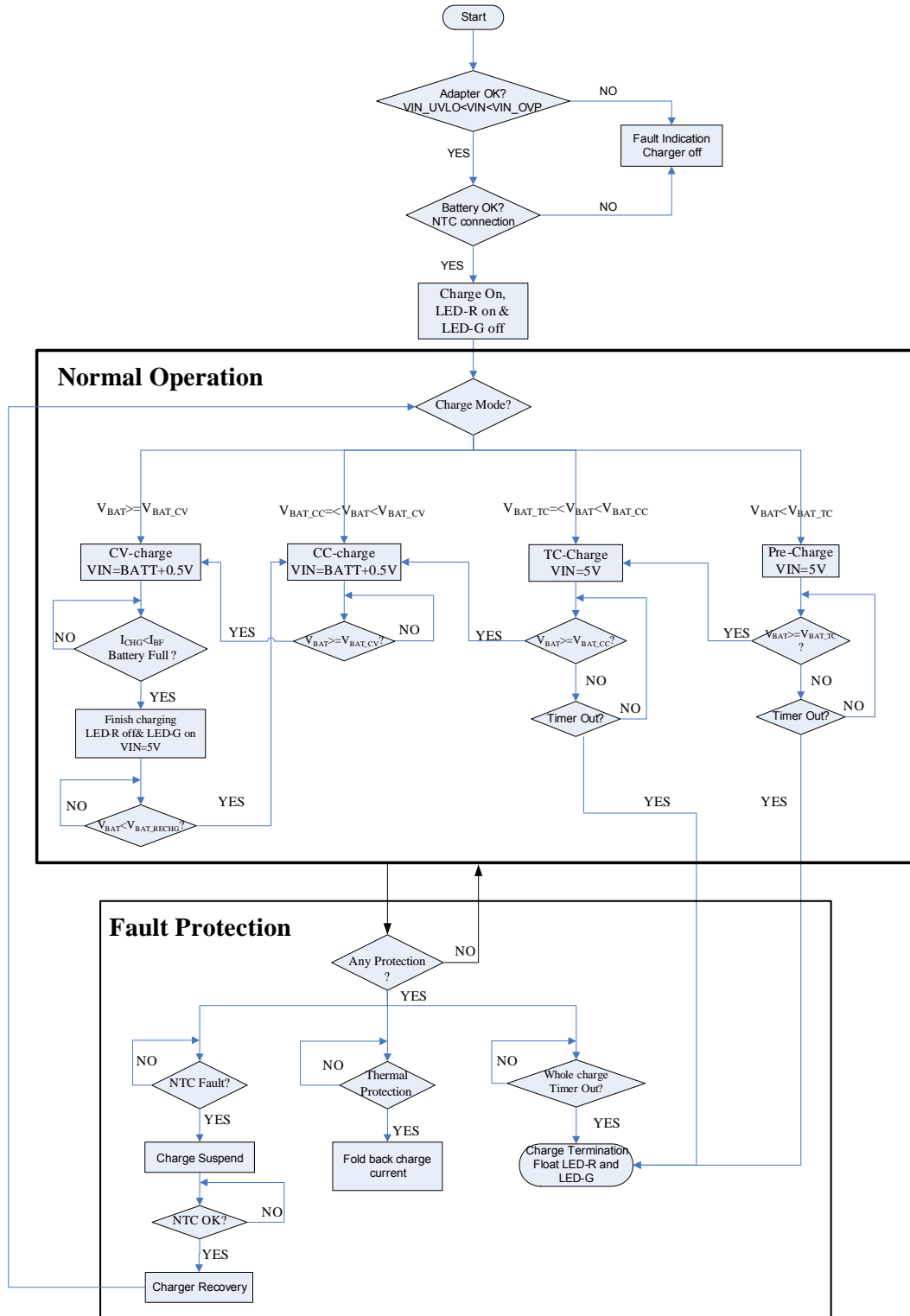
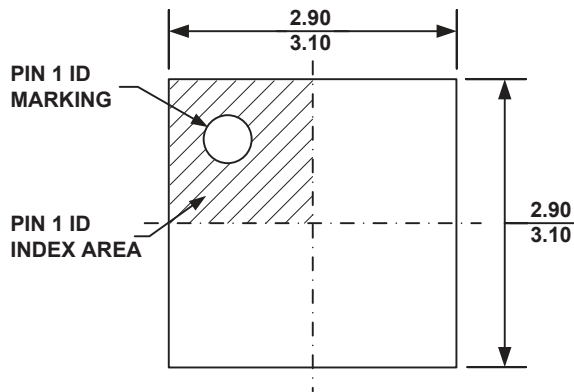

Figure 4— Normal Charge Operation and Fault Protection Flow Chart

PACKAGE INFORMATION

QFN10 (3 X 3 mm)



TOP VIEW

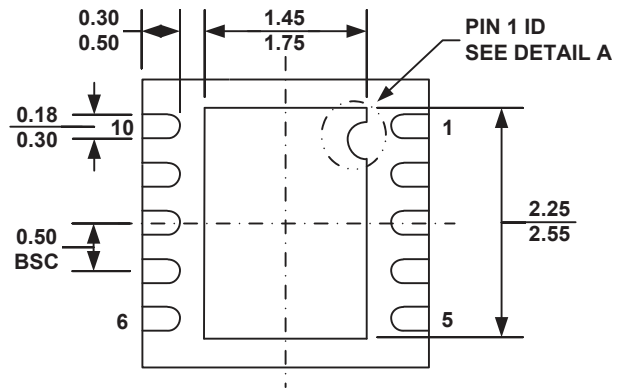

BOTTOM VIEW

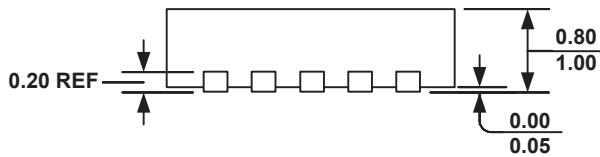

SIDE VIEW

PIN 1 ID OPTION A
R0.20 TYP.

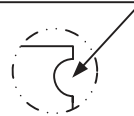

PIN 1 ID OPTION B
R0.20 TYP.

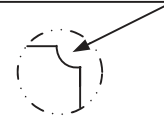

DETAIL A

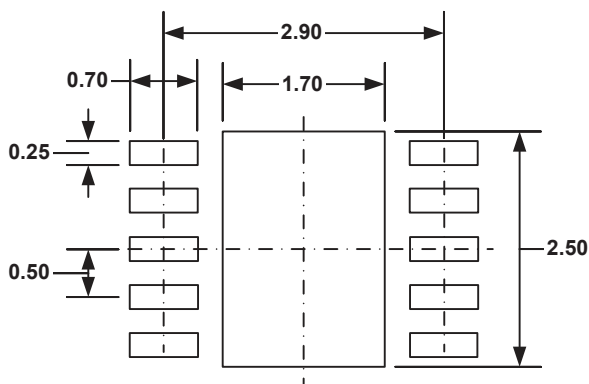

RECOMMENDED LAND PATTERN

NOTE:

- 1) ALL DIMENSIONS ARE IN MILLIMETERS.
- 2) EXPOSED PADDLE SIZE DOES NOT INCLUDE MOLD FLASH.
- 3) LEAD COPLANARITY SHALL BE 0.10 MILLIMETER MAX.
- 4) DRAWING CONFORMS TO JEDEC MO-229, VARIATION VEED-5.
- 5) DRAWING IS NOT TO SCALE.

NOTICE: The information in this document is subject to change without notice. Users should warrant and guarantee that third party Intellectual Property rights are not infringed upon when integrating MPS products into any application. MPS will not assume any legal responsibility for any said applications.