



EVQ7224-QJ-00A

16-Channel, Current Sink LED Driver with Built-In Animation Evaluation Board, AEC-Q100 Qualified

DESCRIPTION

The EVQ7224-QJ-00A evaluation board is designed to demonstrate the capabilities of the MPQ7224, a 16-channel, current sink LED driver. Each channel can achieve up to 200mA of current, and 16 ICs can be cascaded together to create a 256-channel solution.

The MPQ7224 is optimized for animated or dynamic lighting applications. The device employs a 12-bit pulse-width modulation (PWM) dimming register and a 6-bit analog dimming register per channel, allowing for individual control of each channel.

For proper sequencing in animated applications, the MPQ7224 outputs a signal to delay the start-up of one or more ICs via the READYOUT pin.

The MPQ7224 provides adaptive feedback control (AFC) to maximize system efficiency. The pre-regulator's (e.g. buck voltage regulator) output voltage (V_{OUT}) can adjust in real time to keep a constant, 300mV minimum headroom voltage across channels.

The MPQ7224 can aid system design for functional safety via the failsafe (FS) indicator. Full protection features include LED open and short protection, ISET pin open and short protection, and thermal shutdown. If a fault condition occurs, the fault indicator is pulled low.

The MPQ7224 is available in a QFN-32 (5mmx6mm) package with wettable flanks, and is available in AEC-Q100 Grade 1.

PERFORMANCE SUMMARY

Specifications are at $T_A = 25^\circ\text{C}$, unless otherwise noted.

Parameters	Conditions	Value
MPQ4323C input voltage (V_{IN}) range		7V to 36V
MPQ7224 LED load board	Two LEDs ($V_{LED} = 4.8\text{V to }7\text{V}$) in series, total 16 channels	200mA/channel
MPQ7224 maximum LED current (I_{LED})	$V_{BIAS} = 2.5\text{V to }18\text{V}$	200mA/channel

QUICK START GUIDE

The EVQ7224-QJ-00A evaluation board is easy to set up and use to evaluate the performance of the MPQ7224. For proper measurement equipment set-up, refer to Figure 3 on page 5 and follow the steps below:

1. The LED voltage (V_{LED}) depends on the load configuration, described below:
 - a. The default load configuration is two LEDs in series, where V_{LED} is between 4.8V and 7V.
 - b. If the load is greater than two LEDs in series and V_{LED} exceeds 7V, the VBIAS pin voltage (V_{BIAS}) is clamped at 6.8V and the channel triggers LED open protection. The LED does not turn on.
 - c. If the load is less than two LEDs in series and V_{LED} is below 4.8V, the channel triggers LED short protection. The LED flashes and then turns off.
2. Connect an LED load anode to the LED output pad (CN1, 17–20), then connect each LED load cathode to the corresponding LED input pad (CN1, 1–16) on the evaluation board (see Figure 1 and Figure 3 on page 5).

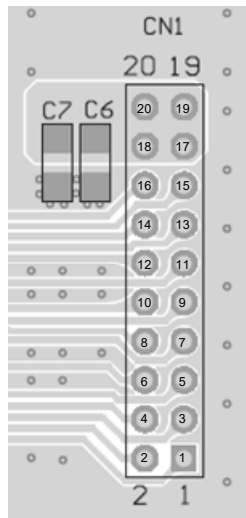

Figure 1: LED Load Connection Configuration

3. Ensure each string has two LEDs in series, and that each LED can hold 200mA of current. If V_{LED} is not within the 4.8V to 7V range, follow steps 19 through 22 to set up the pre-VBIAS voltage (V_{BIAS_PRE}).
4. Preset the power supply (V_{EMI}) to be between 7V and 36V, then turn off the power supply.
5. If longer cables (>0.5m total) are used between the source and the evaluation board, place a damping capacitor at the input terminals, especially when V_{IN} exceeds 24V.
6. Connect the power supply terminals to:
 - a. Positive (+): VEMI
 - b. Negative (-): GND
7. After making the connections, turn on the power supply. The MPQ7224 and LED lights should start up. Do not look directly at the light.
8. To use the enable (EN) function, apply a digital input to the EN pin. Drive EN above 2.2V to turn the regulator on; drive EN below 0.8V to turn it off.
9. The LED current (I_{LED}) is set via the external resistor (R10) (see Figure 4 on page 6), and can be calculated with Equation (1) on page 4:

$$I_{LED} \text{ (mA)} = \frac{600}{R10 \text{ (k}\Omega)} \quad (1)$$

Table 1 shows the recommended resistances for setting I_{LED} .

Table 1: Resistor Selection

I_{LED} (mA)	R10 (k Ω)
200	3.01
100	6.04
50	12.1

10. If the MPQ7224 is in slave mode, set R13 to 0 Ω and remove R14. If adaptive feedback control (AFC) is disabled, or AFC is enabled and the device is in master mode, continue with the default settings for R13 and R14.

11. R3 and R4 form a feedback (FB) divider network that uses AFC to adjust V_{BIAS_PRE} (see Figure 2).

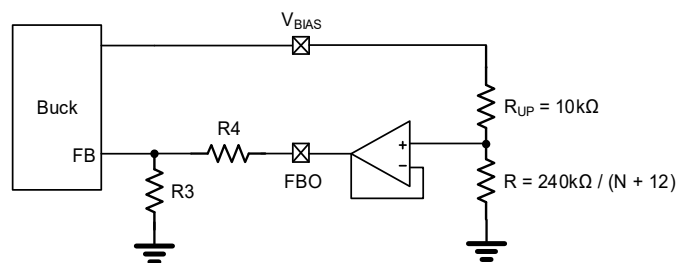

Figure 2: FB Divider Network Set-Up

12. To configure the FB resistor, the FBO pin voltage (V_{FBO}) and V_{BIAS} are required. V_{FBO} can be calculated with Equation (2):

$$V_{FBO} = V_{FB} \times \left(1 + \frac{R4}{R3} \right) \quad (2)$$

Where the FB voltage (V_{FB}) is the reference voltage (V_{REF}) for the DC/DC converter (e.g. 0.8V for the MPQ4323C), and V_{FBO} can be adjusted between 0.6V and 2.2V.

If V_{FBO} is set to 1.2V and R3 is 80.6k Ω , then R4 is 40.2k Ω .

Figure 3 shows the measurement equipment set-up.

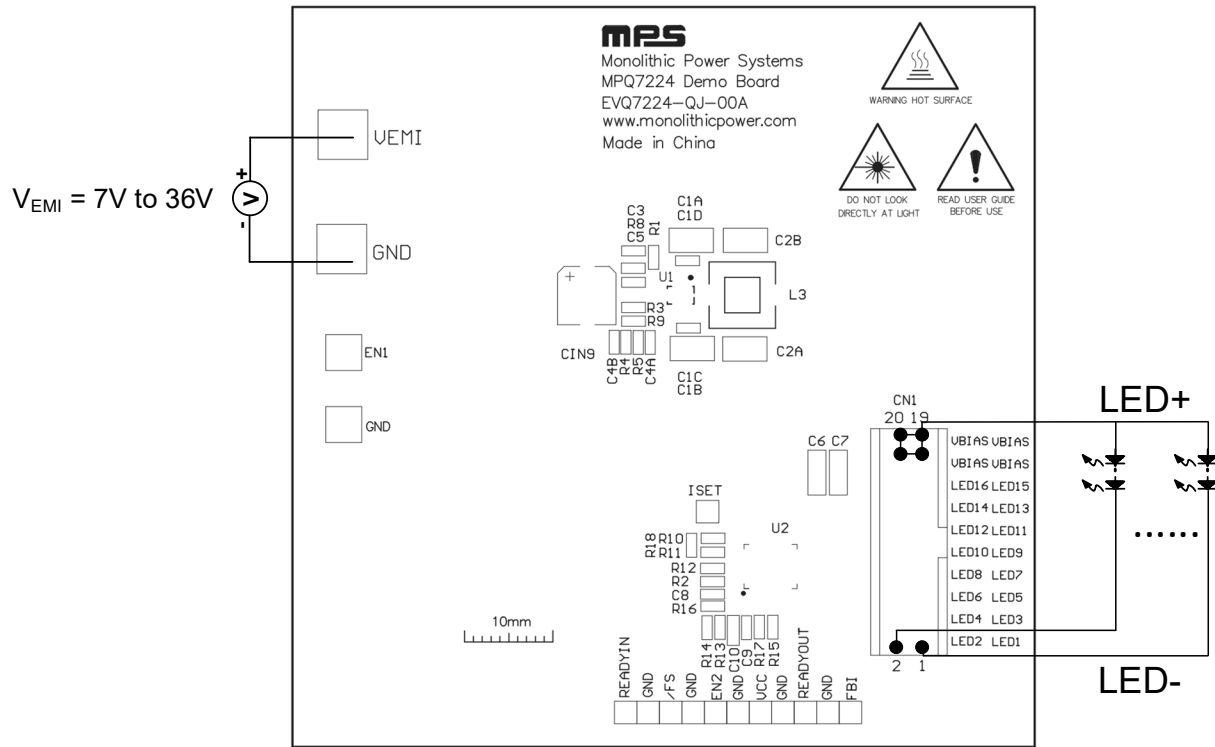

Figure 3: Measurement Equipment Set-Up

EVALUATION BOARD SCHEMATIC

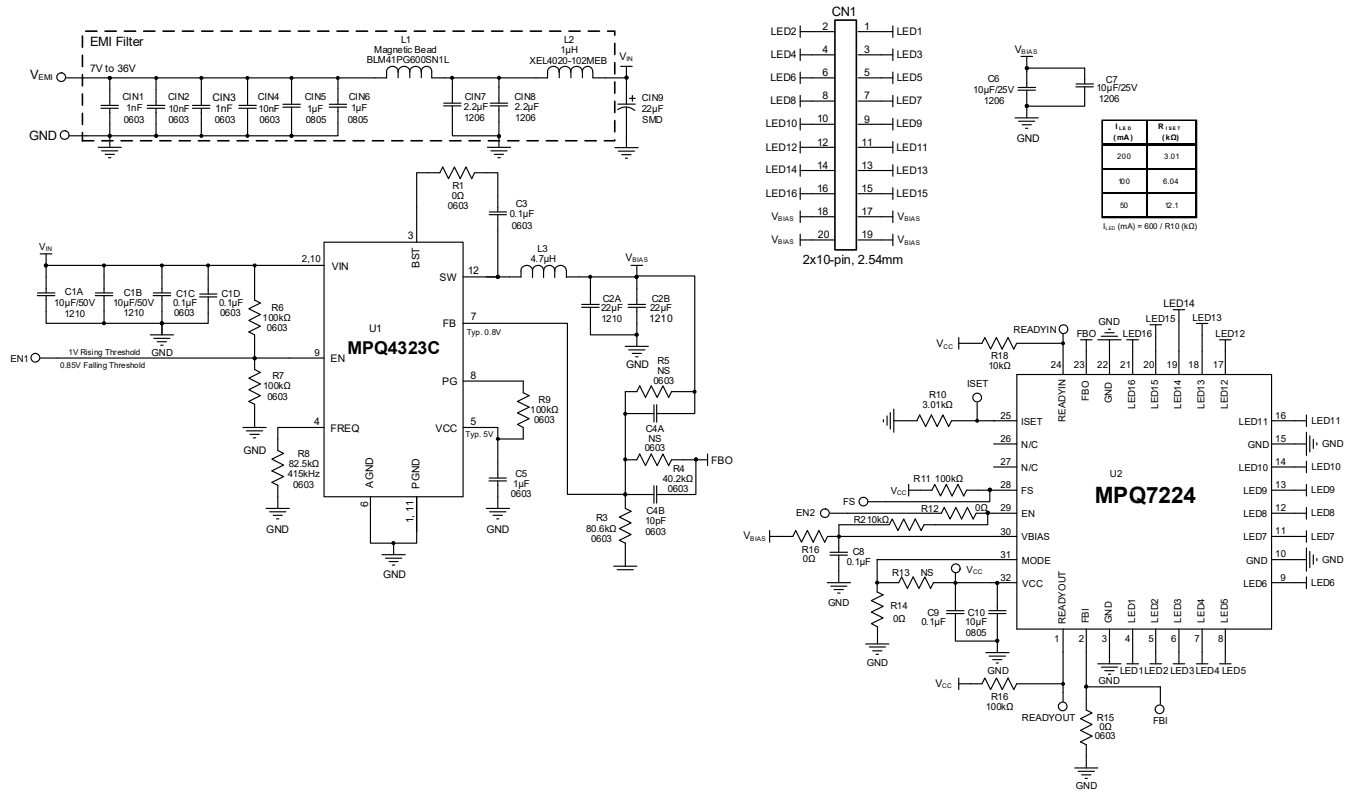

Figure 4: Evaluation Board Schematic

EVQ7224-QJ-00A BILL OF MATERIALS

Qty	Ref	Value	Description	Package	Manufacturer	Manufacturer PN
2	CIN1, CIN3	1nF	Ceramic capacitor, 50V, X7R	0603	Murata	GRM1885C1H102JA01D
2	CIN2, CIN4	10nF	Ceramic capacitor, 50V, X7R	0603	Murata	GRM188R71H103KA01D
2	CIN5, CIN6	1µF	Ceramic capacitor, 50V, X7R	0805	Murata	GRM21BR71H105KA12L
2	CIN7, CIN8	2.2µF	Ceramic capacitor, 50V, X5R	1206	Murata	GRM31CR71H225KA88L
1	CIN9	22µF	Electrolytic capacitor, 50V	SMD	Panasonic	EEHZC1H220P
2	C1A, C1B	10µF	Ceramic capacitor, 50V, X7R	1210	Murata	GRM32ER71H106KA12L
5	C1C, C1D, C3, C8, C9	0.1µF	Ceramic capacitor, 50V, X7R	0603	Murata	GCJ188R71H104KA12D
2	C2A, C2B	22µF	Ceramic capacitor, 16V, X5R	1210	Murata	GRM32ER61C226KE20L
1	C5	1µF	Ceramic capacitor, 10V, X7R	0603	Würth	885012206026
1	C4A	NC				
1	C4B	10pF	Ceramic capacitor, 50V, NPO	0603	Würth	885012006051
2	C6, C7	10µF	Ceramic capacitor, 25V, X7R	1206	Murata	GRM31CR71E106KA12
1	C10	10µF	Ceramic capacitor, 10V, X7R	0805	Murata	GRM21BR71A106KE51L
1	L1	6A	Magnetic bead	1806	Murata	BLM41PG600SN1L
1	L2	1µH	Inductor	SMD	Coilcraft	XEL4020-102MEB
1	L3	4.7µH	Inductor	SMD	Coilcraft	XAL5030-472MEB
5	R1, R12, R14, R15, R16	0Ω	Film resistor, 5%	0603	Yageo	RC0603JR-070RL
2	R2, R18	10kΩ	Film resistor, 1%	0603	Yageo	RC0603FR-0710KL
1	R4	40.2kΩ	Film resistor, 1%	0603	Yageo	RC0603FR-0740K2L
1	R3	80.6kΩ	Film resistor, 1%	0603	Yageo	RC0603FR-0780K6L
2	R5, R13	NC				
5	R6, R7, R9, R11, R17	100kΩ	Film resistor, 1%	0603	Yageo	RC0603FR-07100KL
1	R8	82.5kΩ	Film resistor, 1%	0603	Yageo	RC0603FR-0782K5L
1	R10	3.01kΩ	Film resistor, 1%	0603	Yageo	RC0603FR-073K01L
2	VEMI, GND	2mm	Golden pin	DIP	Custom ⁽¹⁾	
2	EN1, GND	1mm	Golden pin	DIP	Custom ⁽¹⁾	
1	READYIN, /FS, EN2, VCC, READYOUT, FBI, GND	2.54mm	Test pin	DIP	Custom ⁽¹⁾	
1	CN1	2.54mm	Test pin	DIP	Custom ⁽¹⁾	

**EVQ7224-QJ-00A BILL OF MATERIALS** *(continued)*

Qty	Ref	Value	Description	Package	Manufacturer	Manufacturer PN
1	U1	MPQ4323C-AEC1	42 load dump, 3A, synchronous step-down converter, AEC-Q100	QFN-12 (2mmx3mm)	MPS	MPQ4323CGDE-AEC1
1	U2	MPQ7224-AEC1	16-channel, current sink LED driver, AEC-Q100 qualified	QFN-32 (5mmx6mm)	MPS	MPQ7224GQJE-0000-AEC1

Note:

- 1) MPS custom-produces these pins. Contact an MPS FAE for more information.

EVB TEST RESULTS

Two LEDs in series ($V_{LED} = 6V$), $I_{LED}/ch = 200mA$, $T_A = 25^{\circ}C$, unless otherwise noted. (2)

CISPR 25 Class 5 Peak Conducted Emissions

150kHz to 108MHz

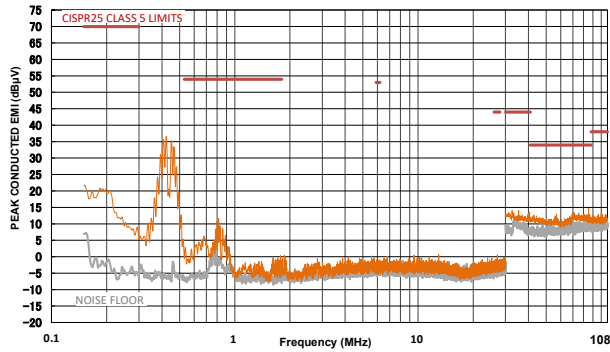

CISPR 25 Class 5 Average Conducted Emissions

150kHz to 108MHz

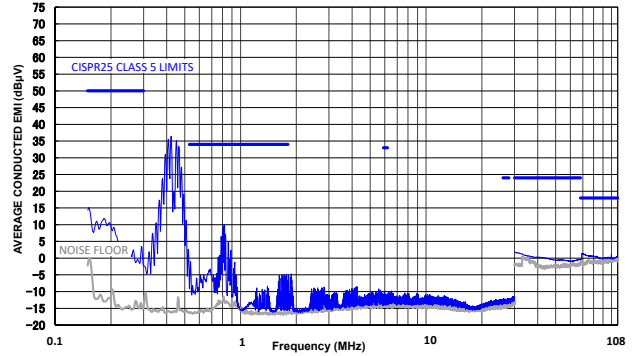

CISPR 25 Class 5 Peak Radiated Emissions

150kHz to 30MHz

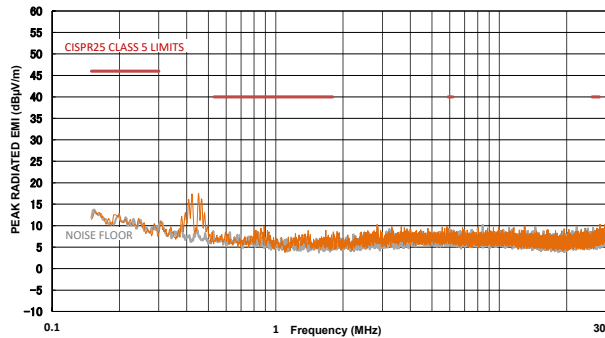

CISPR 25 Class 5 Average Radiated Emissions

150kHz to 30MHz

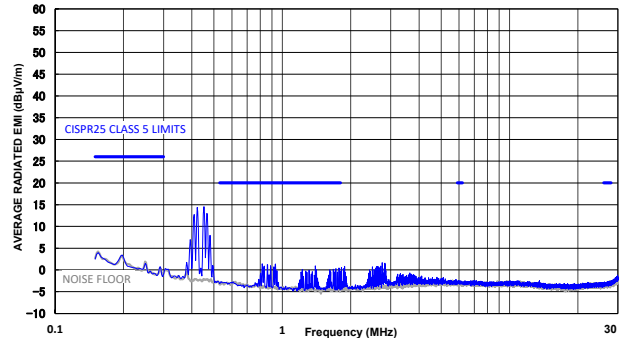

CISPR 25 Class 5 Peak Radiated Emissions

Horizontal, 30MHz to 200MHz

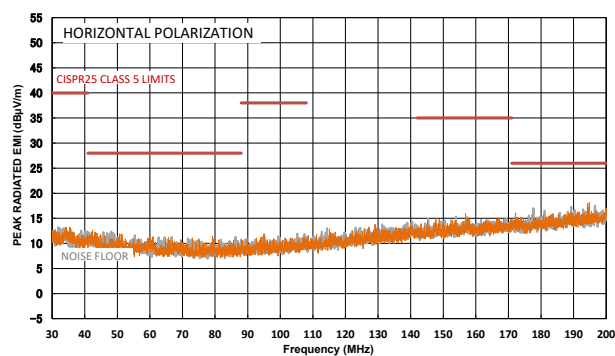

CISPR 25 Class 5 Average Radiated Emissions

Horizontal, 30MHz to 200MHz

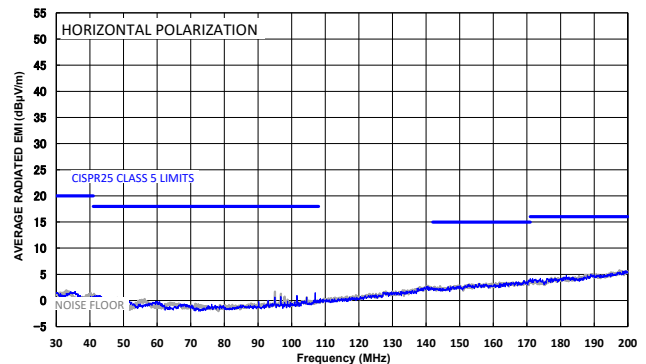

EVB TEST RESULTS (continued)

Two LEDs in series ($V_{LED} = 6V$), $I_{LED}/ch = 200mA$, $T_A = 25^\circ C$, unless otherwise noted. (2)

CISPR 25 Class 5 Peak Radiated Emissions

Vertical, 30MHz to 200MHz

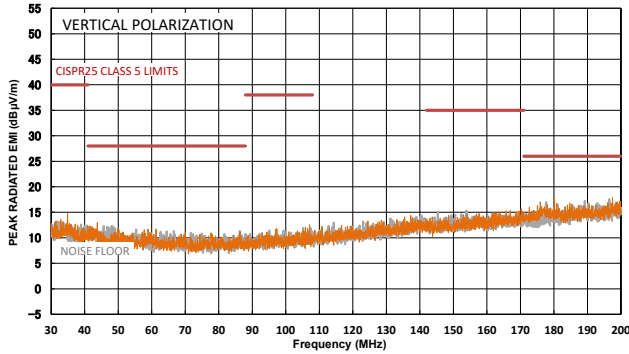

CISPR 25 Class 5 Average Radiated Emissions

Vertical, 30MHz to 200MHz

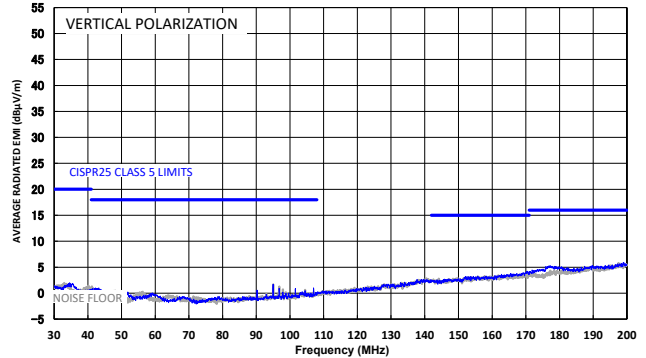

CISPR 25 Class 5 Peak Radiated Emissions

Horizontal, 200MHz to 1GHz

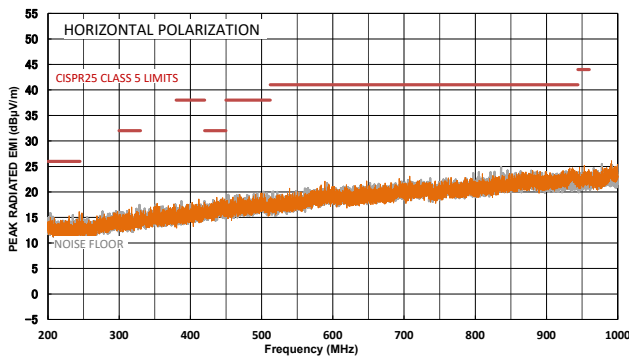

CISPR 25 Class 5 Average Radiated Emissions

Horizontal, 200MHz to 1GHz

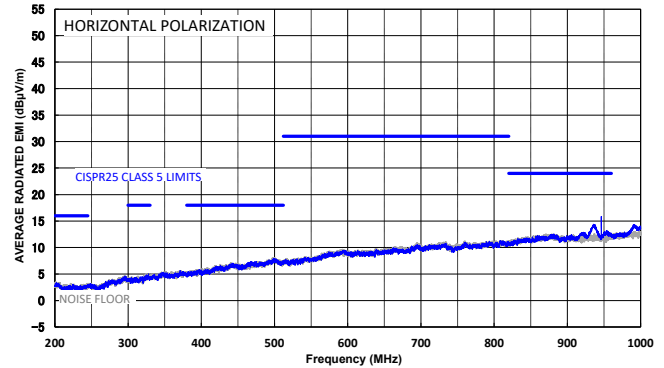

CISPR 25 Class 5 Peak Radiated Emissions

Vertical, 200MHz to 1GHz

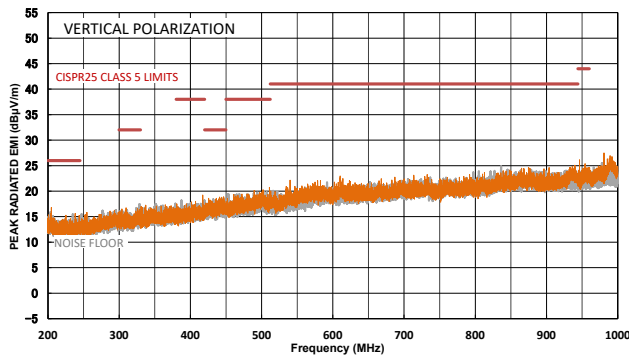

CISPR 25 Class 5 Average Radiated Emissions

Vertical, 200MHz to 1GHz

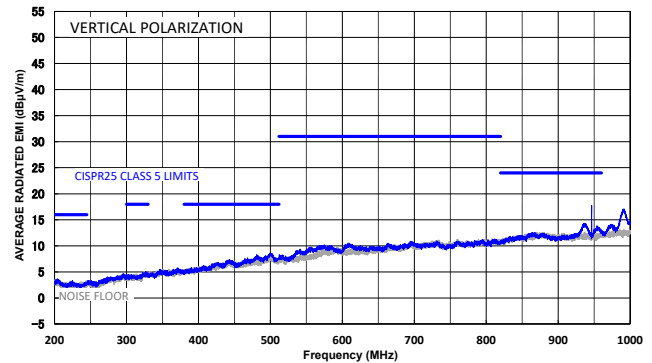

EVB TEST RESULTS (continued)

Two LEDs in series ($V_{LED} = 6V$), $I_{LED}/ch = 200mA$, $T_A = 25^{\circ}C$, unless otherwise noted. (2)

CISPR 25 Class 5 Peak Conducted Emissions

150kHz to 108MHz

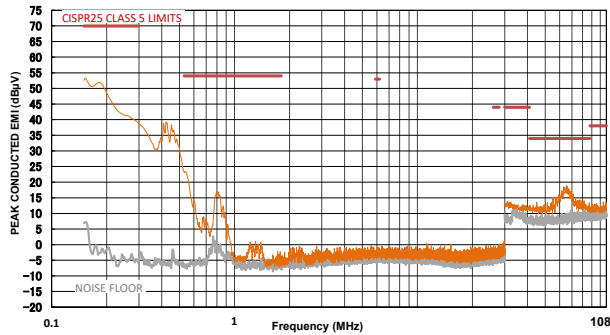

CISPR 25 Class 5 Average Conducted Emissions

150kHz to 108MHz

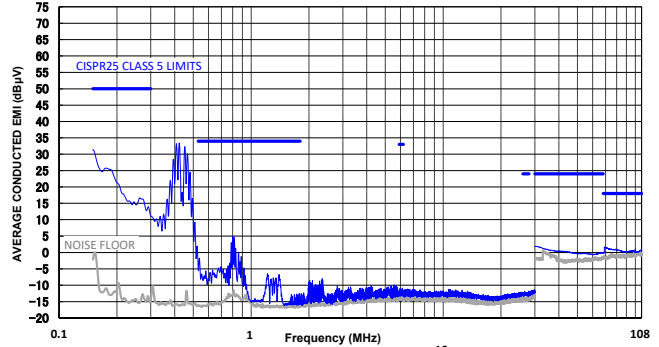

CISPR 25 Class 5 Peak Radiated Emissions

150kHz to 30MHz

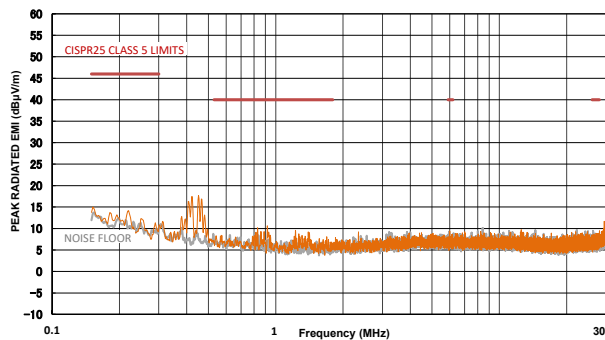

CISPR 25 Class 5 Average Radiated Emissions

150kHz to 30MHz

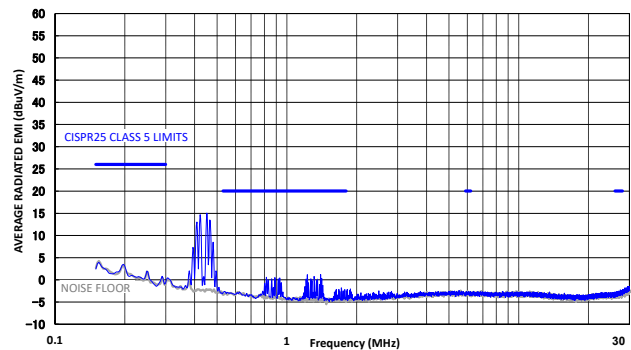

CISPR 25 Class 5 Peak Radiated Emissions

Horizontal, 30MHz to 200MHz

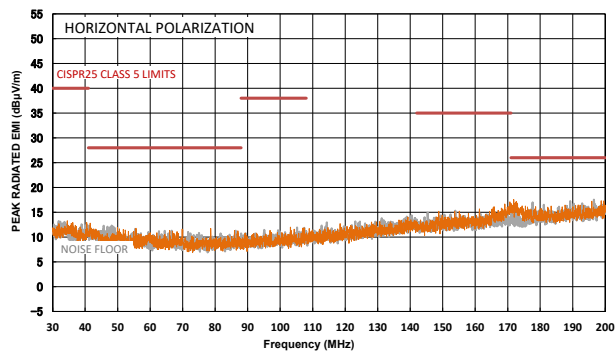

CISPR 25 Class 5 Average Radiated Emissions

Horizontal, 30MHz to 200MHz

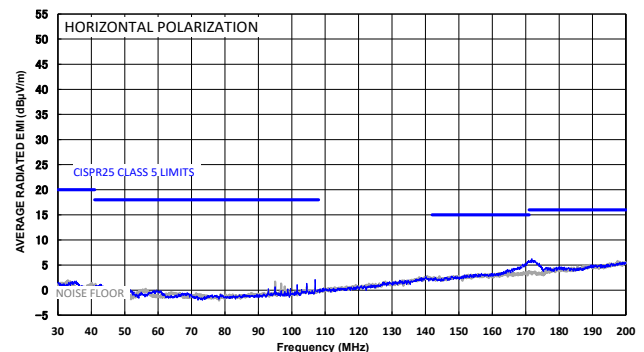

EVB TEST RESULTS (continued)

Two LEDs in series ($V_{LED} = 6V$), $I_{LED}/ch = 200mA$, $T_A = 25^{\circ}C$, unless otherwise noted. (2)

CISPR 25 Class 5 Peak Radiated Emissions

Vertical, 30MHz to 200MHz

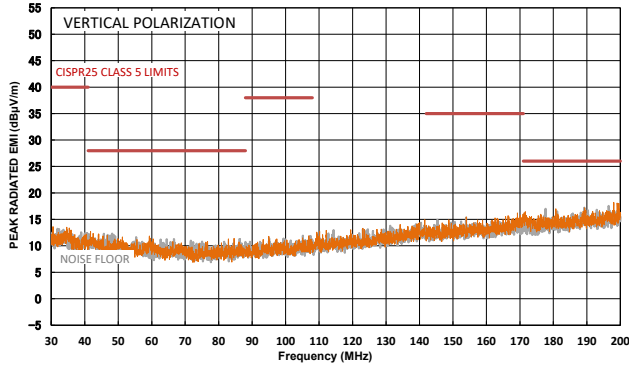

CISPR 25 Class 5 Average Radiated Emissions

Vertical, 30MHz to 200MHz

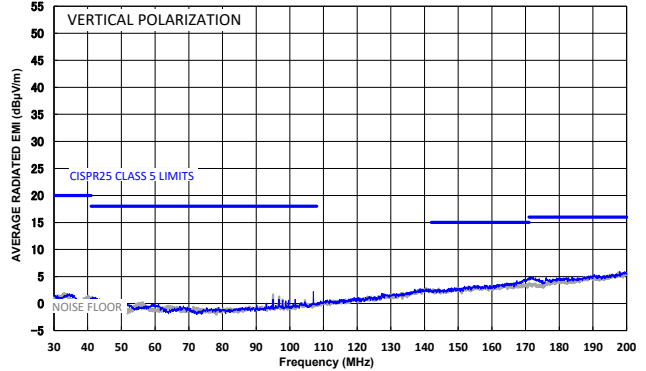

CISPR 25 Class 5 Peak Radiated Emissions

Horizontal, 200MHz to 1GHz

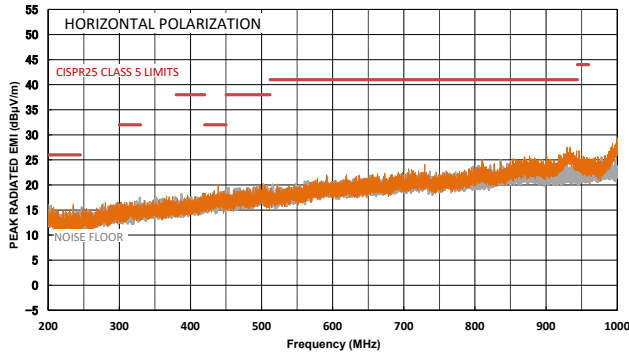

CISPR 25 Class 5 Average Radiated Emissions

Horizontal, 200MHz to 1GHz

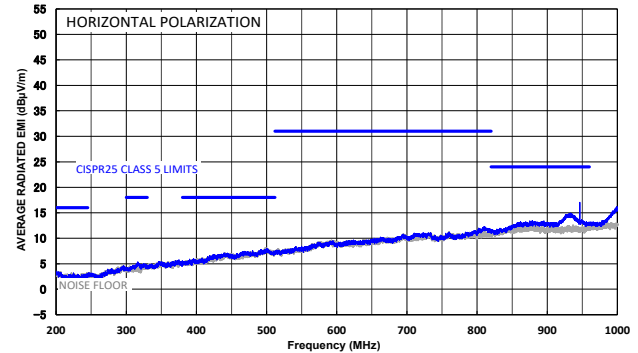

CISPR 25 Class 5 Peak Radiated Emissions

Vertical, 200MHz to 1GHz

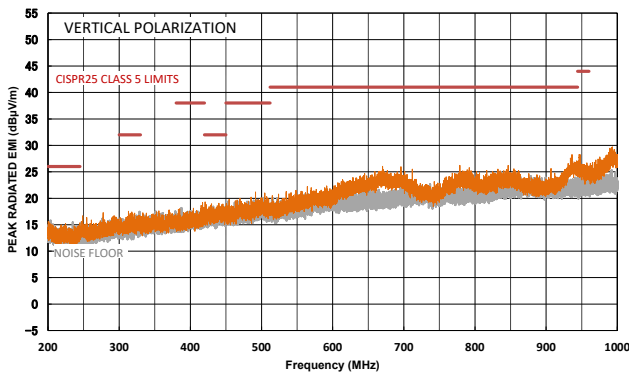

CISPR 25 Class 5 Average Radiated Emissions

Vertical, 200MHz to 1GHz

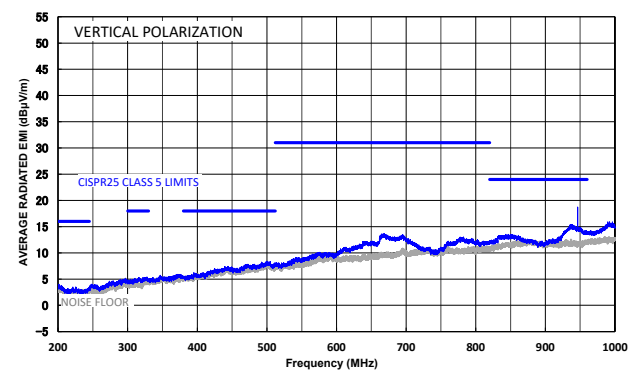

Note:

- The EMC test results are based on the schematic with EMI filters (see Figure 4 on page 6), where $f_{PWM} = 250Hz$, duty cycle = 50%, phase shift = $1\mu s$, and slew rate = $5\mu s$.

EVB TEST RESULTS (continued)

Two LEDs in series ($V_{LED} = 6V$), $I_{LED}/ch = 200mA$, $T_A = 25^{\circ}C$, unless otherwise noted.

Immediate Animation

READYIN is on

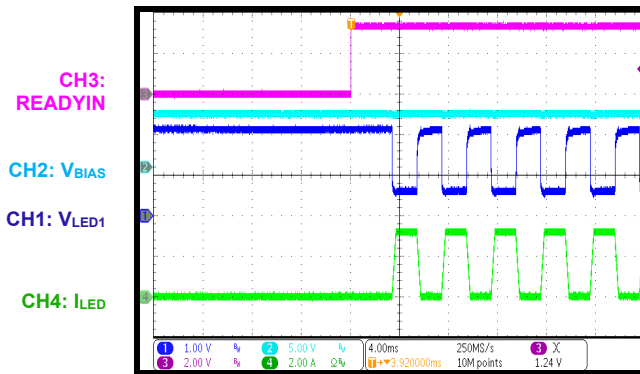

Immediate Animation

READYIN is off

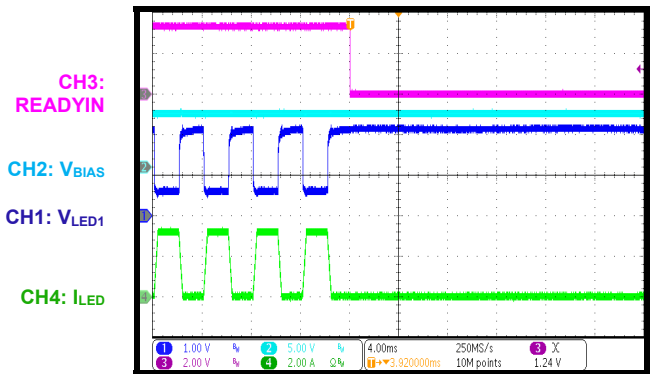

Immediate Animation

Steady state

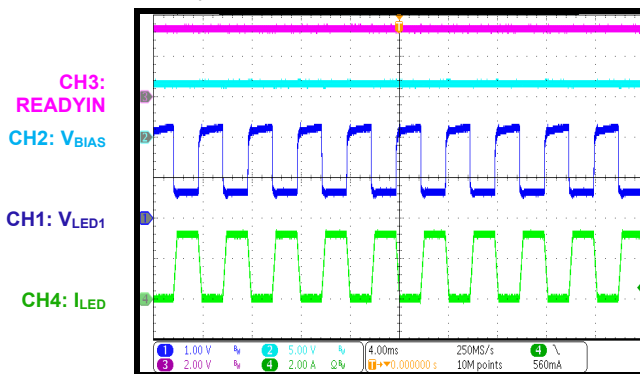

Breathing Animation

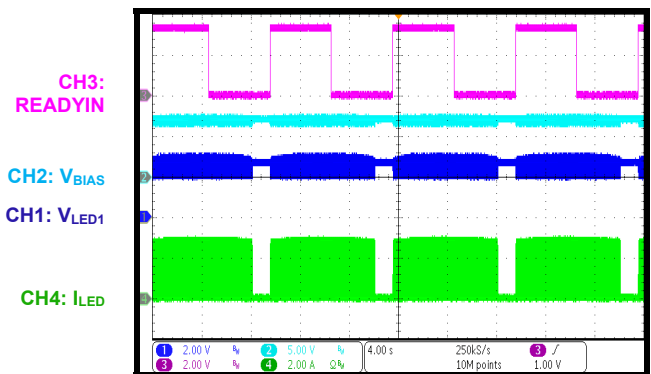

Breathing Animation

READYIN is on

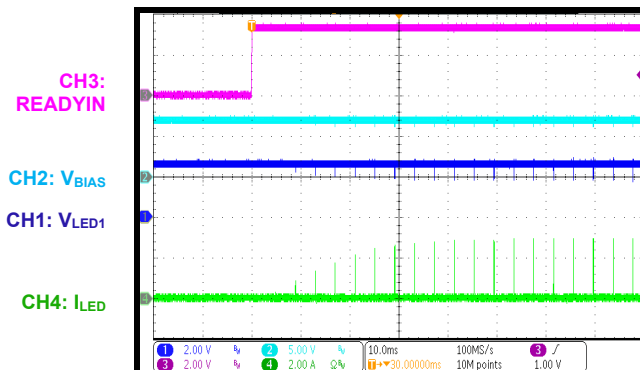

Breathing Animation

READYIN is off

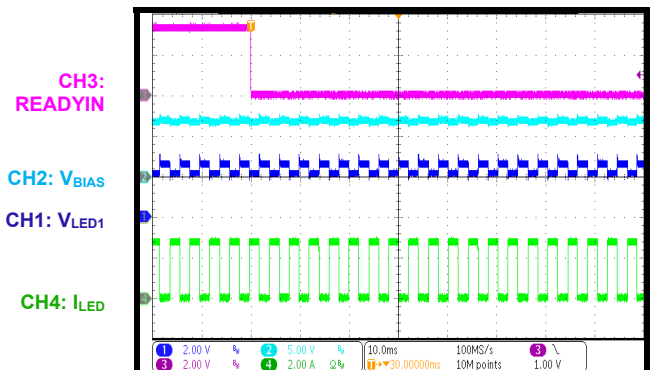

EVB TEST RESULTS (continued)

Two LEDs in series ($V_{LED} = 6V$), $I_{LED}/ch = 200mA$, $T_A = 25^{\circ}C$, unless otherwise noted.

Sequential Animation

READYIN is on

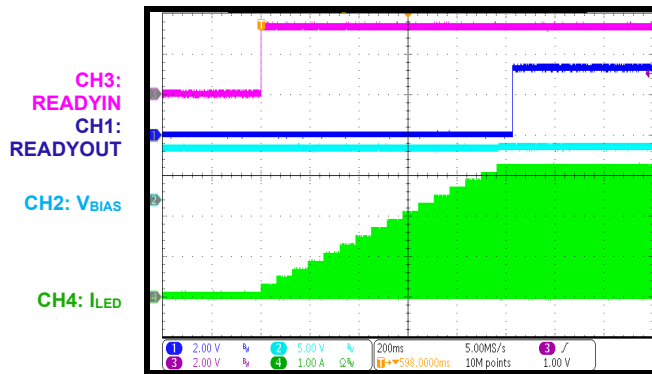

Sequential Animation

READYIN is off

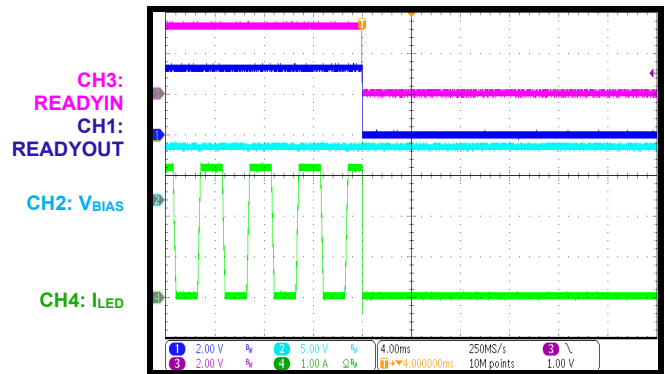

VBIAS Short to LED1 Entry

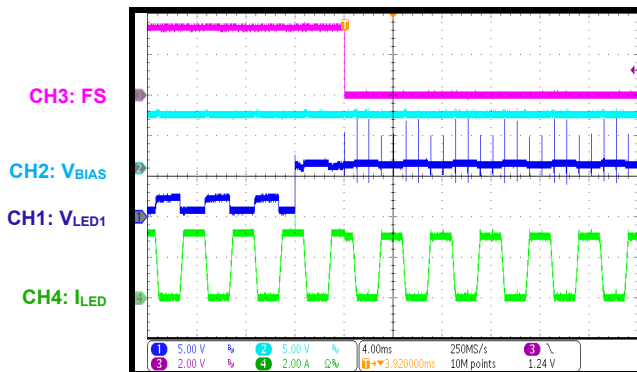

VBIAS Short to LED1 Steady State

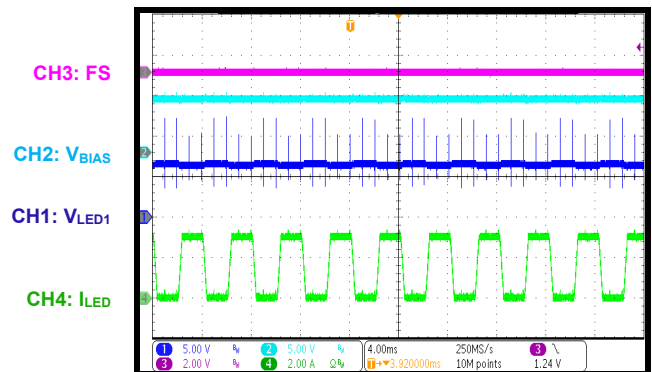

VBIAS Short to LED1 Recovery

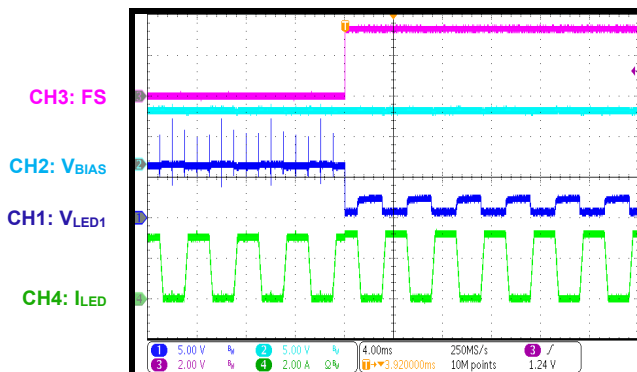

LED Open Entry

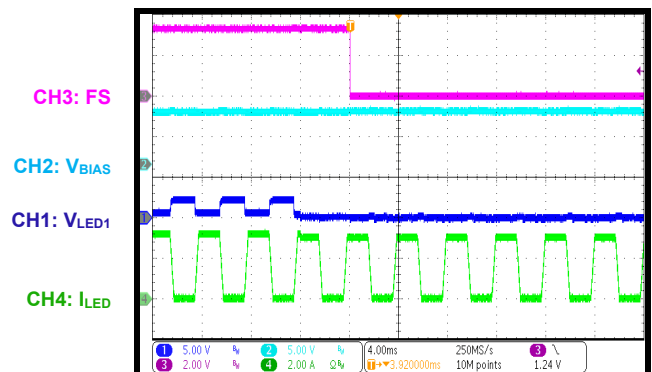

EVB TEST RESULTS (continued)

Two LEDs in series ($V_{LED} = 6V$), $I_{LED}/ch = 200mA$, $T_A = 25^{\circ}C$, unless otherwise noted.

LED Open Recovery

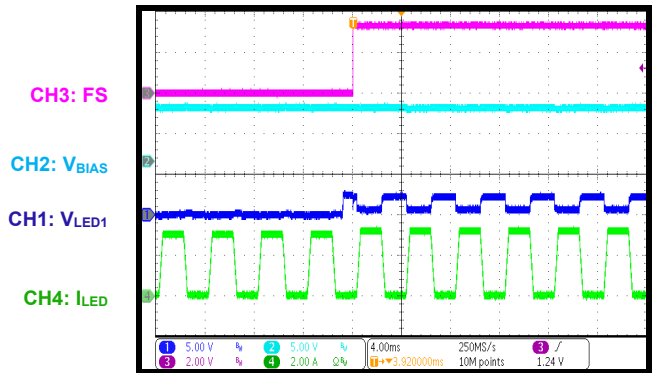

ISET Pin Short

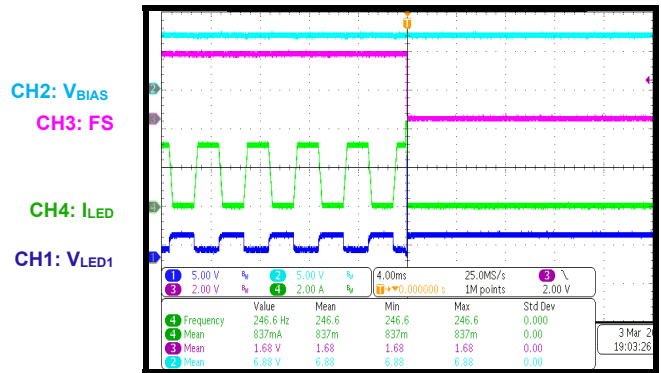

ISET Pin Open

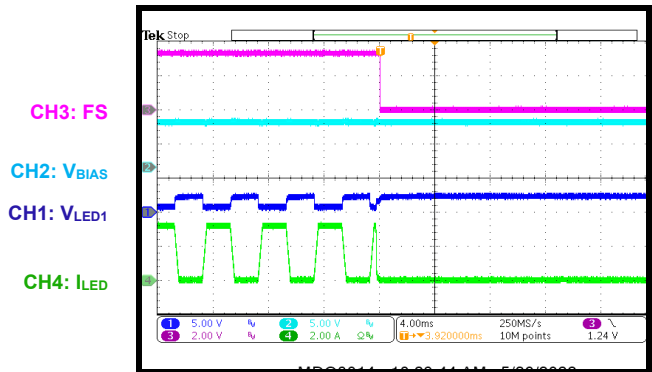

Start-Up

READYIN is connected to VBIAS

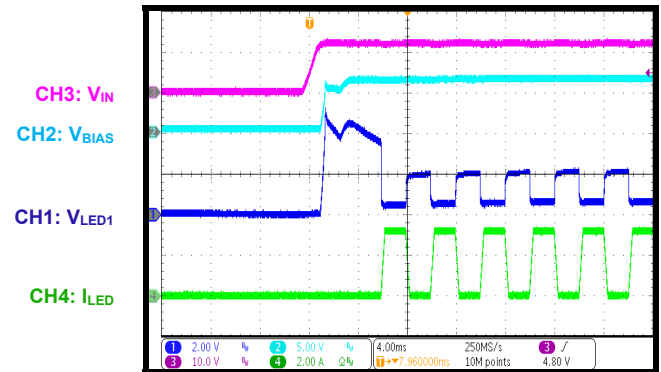

Shutdown

READYIN is connected to VBIAS

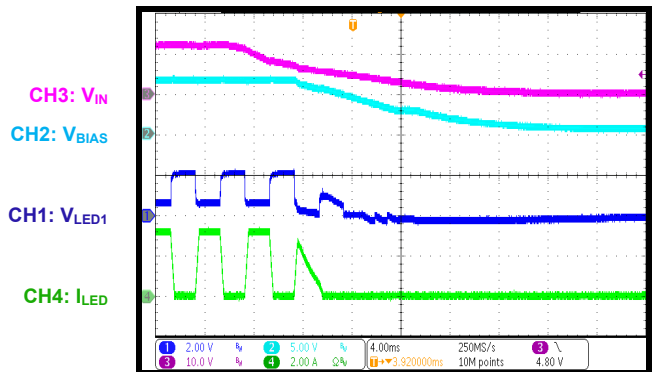

PCB LAYOUT (3)

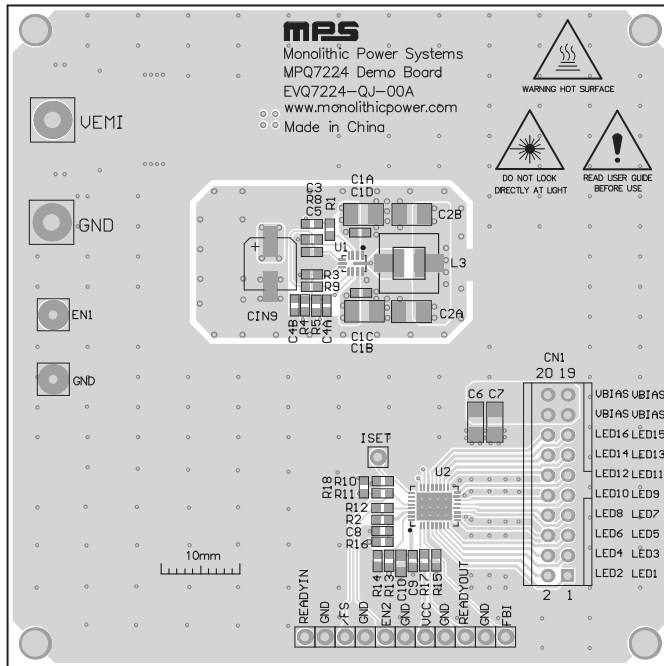

Figure 5: Top Silk and Top Layer

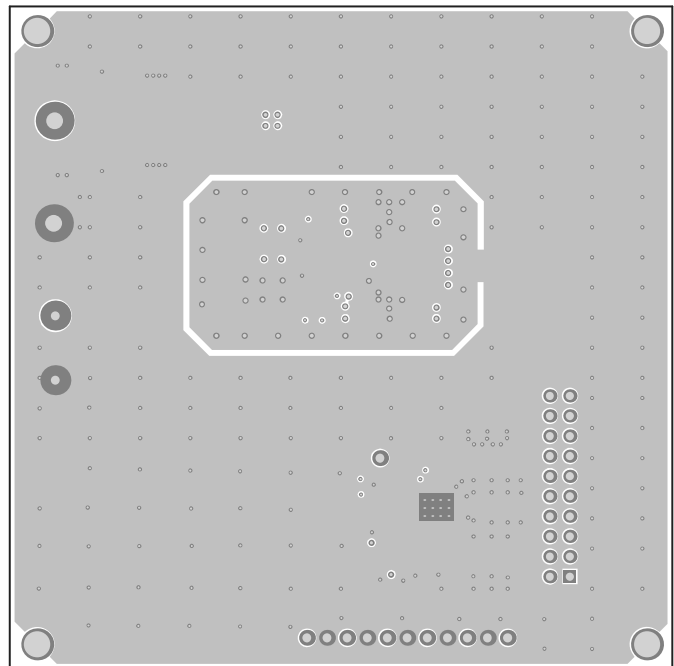

Figure 6: Mid-Layer 1

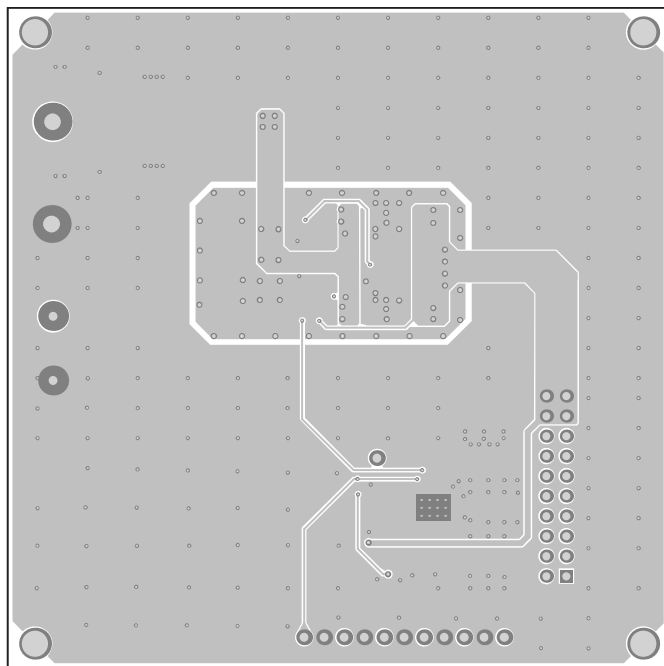

Figure 7: Mid-Layer 2

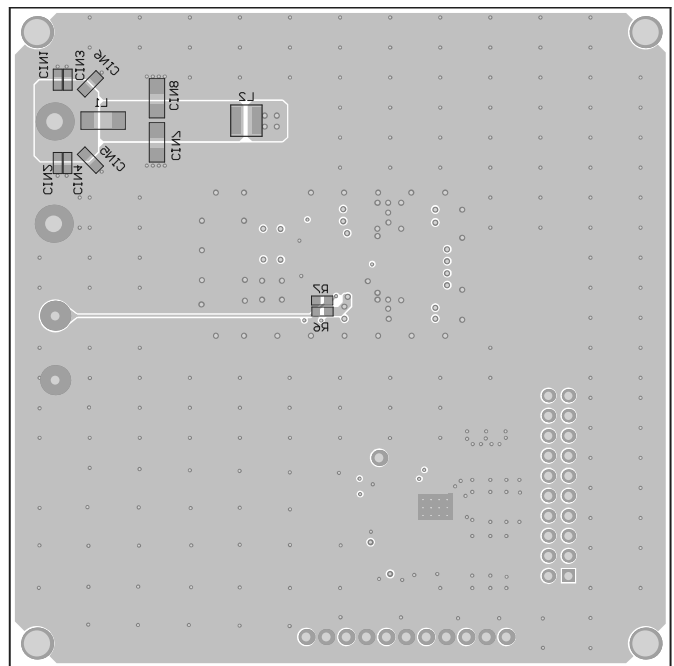

Figure 8: Bottom Layer and Bottom Silk

Note:

3) The EVQ7224-QJ-00A is a 4-layer, 2oz PCB (83.5mmx83.5mm).



REVISION HISTORY

Revision #	Revision Date	Description	Pages Updated
1.0	10/22/2024	Initial Release	-

Notice: The information in this document is subject to change without notice. Please contact MPS for current specifications. Users should warrant and guarantee that third-party Intellectual Property rights are not infringed upon when integrating MPS products into any application. MPS will not assume any legal responsibility for any said applications.