



EVQ4334-D-4000-00A

36V, 4A, Low Quiescent Current, Synchronous Step-Down Converter Evaluation Board in QFN-12 (2mmx3mm), AEC-Q100 Qualified

DESCRIPTION

The EVQ4334-D-4000-00A is an evaluation board designed to demonstrate the capabilities of the MPQ4334GDE-4000-AEC1, a configurable-frequency (200kHz to 2.5MHz), synchronous, step-down switching converter with an integrated, internal high-side MOSFET (HS-FET) and low-side MOSFET (LS-FET).

The MPQ4334GDE-4000-AEC1 provides up to 4A of highly efficient output current (I_{OUT}) with peak current mode control. The wide 3V to 36V input voltage (V_{IN}) range and 40V load dump tolerance accommodates a variety of step-down applications in automotive input environments. A 0.5 μ A shutdown mode quiescent current (I_Q) allows the device to be used in battery-powered applications.

High power conversion efficiency across a wide load range is achieved by scaling down the switching frequency (f_{SW}) under light-load

conditions to reduce switching and gate driver losses.

An open-drain power good (PG) signal indicates whether the output voltage (V_{OUT}) is within 94.5% to 105.5% of its nominal voltage.

Frequency foldback helps prevent inductor current (I_L) runaway during start-up. Thermal shutdown provides reliable, fault-tolerant operation.

High duty cycle and low-dropout (LDO) mode are provided for automotive cold-crank conditions.

The EVQ4334-D-4000-00A is a fully assembled and tested evaluation board. The MPQ4334GDE-4000-AEC1 is available in a QFN-12 (2mmx3mm) package with wettable flanks, and is AEC-Q100 qualified.

PERFORMANCE SUMMARY

Specifications are at $T_A = 25^\circ\text{C}$, unless otherwise noted.

Parameters	Conditions	Value
Input voltage (V_{IN}) range		3V to 36V
Output voltage (V_{OUT})	$V_{IN} = 6V$ to 36V, $I_{OUT} = 0A$ to 4A	5V
Maximum output current (I_{OUT})	$V_{IN} = 3V$ to 36V	4A
Typical efficiency	$V_{IN} = 12V$, $V_{OUT} = 5V$, $I_{OUT} = 4A$	91.5%
Peak efficiency	$V_{IN} = 8V$, $V_{OUT} = 5V$, $I_{OUT} = 1A$	96%
Switching frequency (f_{SW})		2.2MHz

EVQ4334-D-4000-00A EVALUATION BOARD



LxWxH (8.3cmx8.3cmx1cm)

Board Number	MPS IC Number
EVQ4334-D-4000-00A	MPQ4334GDE-4000-AEC1

QUICK START GUIDE

The EVQ4334-D-4000-00A evaluation board is easy to set up and use to evaluate the performance of the MPQ4334. For proper measurement equipment set-up, refer to Figure 2 on page 4 and follow the steps below:

1. Preset the power supply (V_{IN}) to be between 6V and 36V, then turn off the power supply.
2. Set the load current between 0A and 4A. Electronic loads represent a negative impedance to the regulator, and setting the current too high can trigger hiccup mode.
3. If longer cables (>0.5m total) are used between the source and the evaluation board, place a damping capacitor at the input terminals (especially when $V_{IN} \geq 24V$).
4. Connect the power supply terminals to:
 - a. Positive (+): VEMI
 - b. Negative (-): GND
5. Connect the load terminals to:
 - a. Positive (+): VOUT
 - b. Negative (-): GND
6. After making the connections, turn on the power supply. The board should start up automatically.
7. To use the enable (EN) function, apply a digital input to the EN pin. Pull EN above 1.02V to turn the regulator on; pull EN below 0.85V to turn it off. If the enable function is not used, EN can be connected directly to V_{IN} .
8. Connect a resistor between the FREQ and GND pins to set the internal switching frequency (f_{sw}).
9. Set the output voltage (V_{OUT}) using the external resistor divider (see Figure 1).

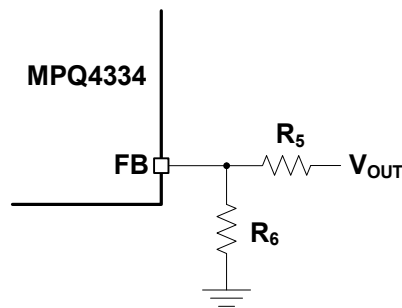

Figure 1: Feedback Divider Network with Adjustable Output

R_5 should be 100k Ω . Then R_6 can be calculated with Equation (1):

$$R_6 = \frac{R_5}{\frac{V_{OUT}}{0.8V} - 1} \quad (1)$$

Refer to the Application Information section in the MPQ4334 datasheet to calculate the inductance (L) and output capacitance (C_{OUT}) for different output voltages.

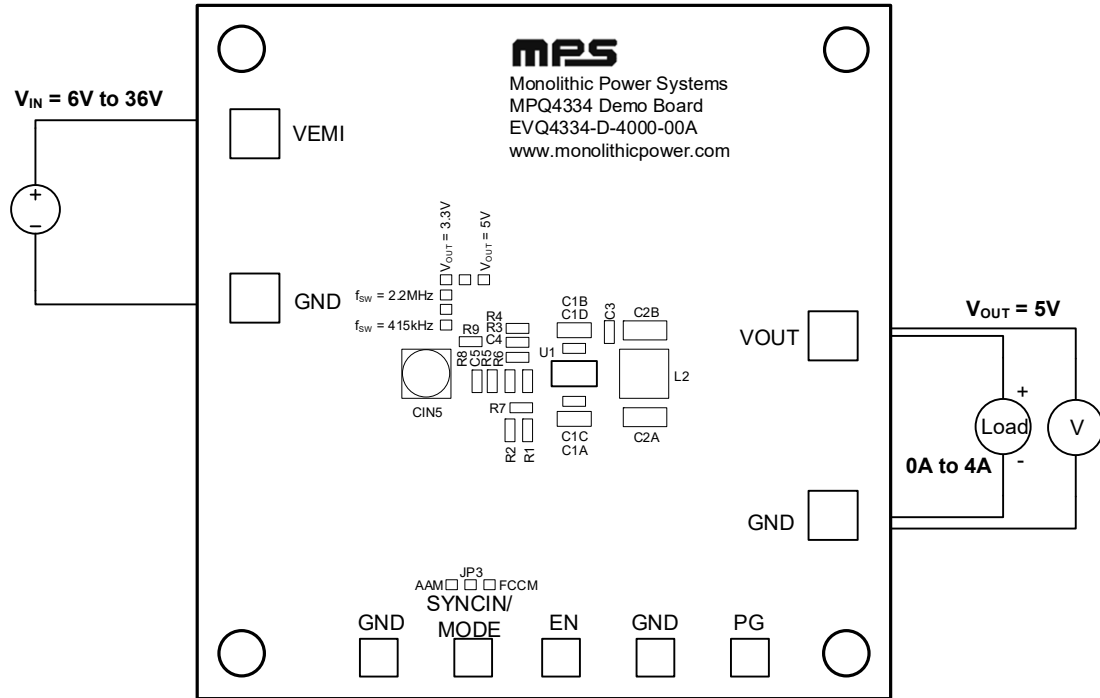

Figure 2: Measurement Equipment Set-Up

EVALUATION BOARD SCHEMATIC

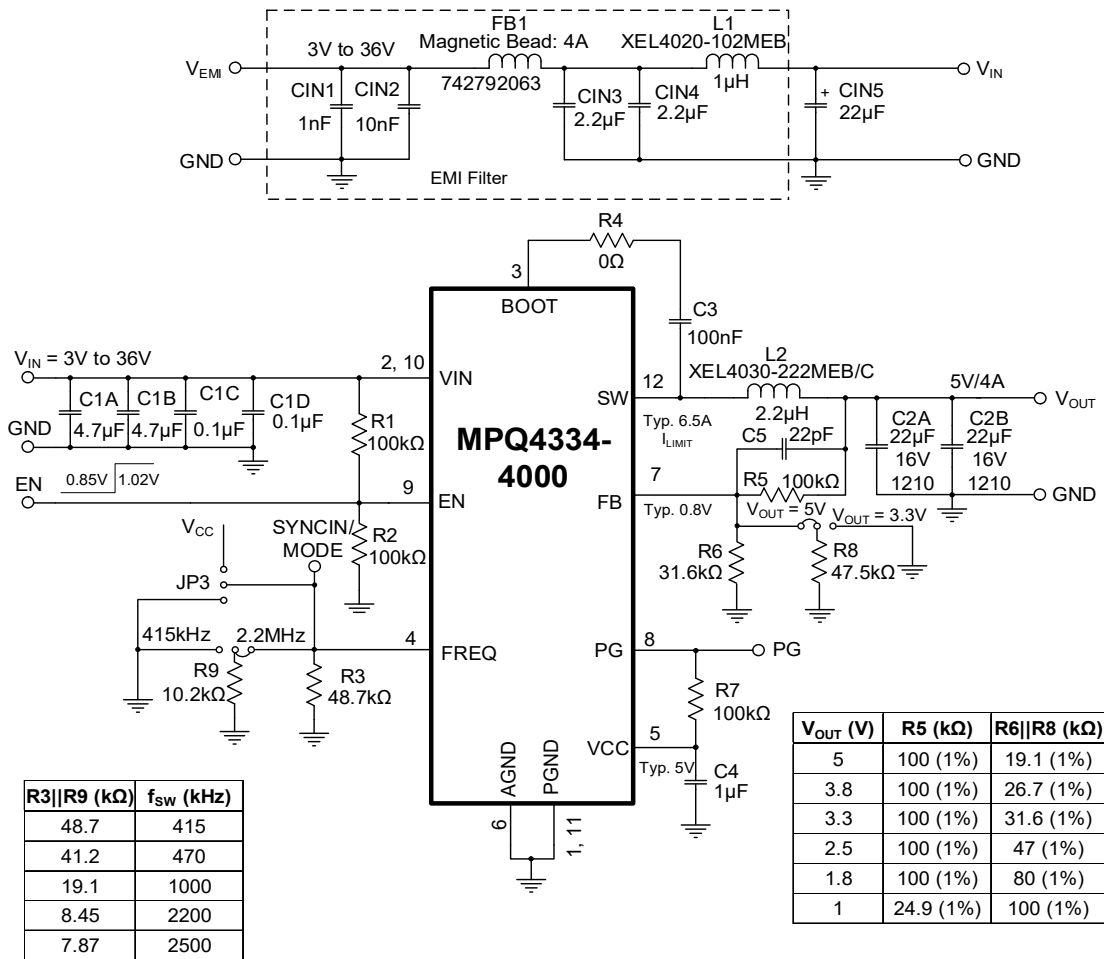
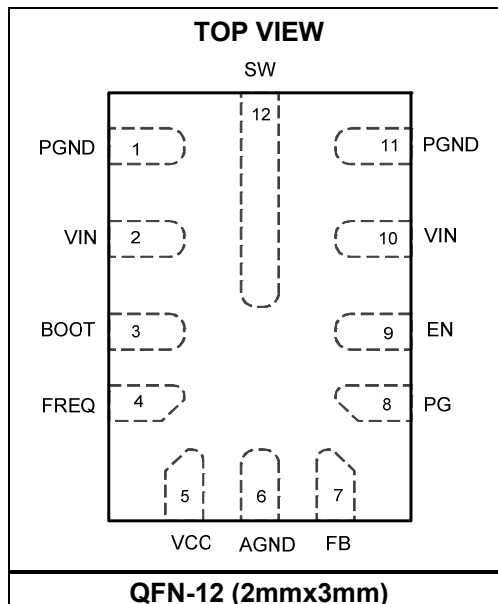

Figure 3: Evaluation Board Schematic

PACKAGE REFERENCE



EVQ4334-D-4000-00A BILL OF MATERIALS

Qty	Ref	Value	Description	Package	Manufacturer	Manufacturer PN
1	CIN1	1nF	Ceramic capacitor, 50V, X7R	0603	Murata	GRM216R71H102KA01
1	CIN2	10nF	Ceramic capacitor, 50V, X7R	0603	Murata	GRM188R71H103KA01D
2	CIN3, CIN4	2.2 μ F	Ceramic capacitor, 50V, X7R	0805	Murata	GRM21BD72A225KE01L
1	CIN5	22 μ F	Aluminum polymer capacitor, 50V	SMD	Panasonic	EEHZC1H220P
2	C1A, C1B	4.7 μ F	Ceramic capacitor, 50V, X7S	1206	Murata	GRM31CR71H475KA12L
3	C1C, C1D, C3	100nF	Ceramic capacitor, 50V, X7R	0603	Murata	GRM188R71H104KA93D
2	C2A, C2B	22 μ F	Ceramic capacitor, 16V, X7R	1210	Murata	GRM32ER71C226KE18L
1	C5	22pF	Ceramic capacitor, 100V, C0G	0603	Murata	GCM1885C2A220JA16D
1	C4	1 μ F	Ceramic capacitor, 25V, X7R	0603	Murata	GCM188R71E105KA64D
1	FB1	3A	Magnetic bead	0805	Würth	742792063
1	L1	1 μ H	Inductor, 14.6m Ω , 9.6A	SMD	Coilcraft	XEL4020-102MEB
1	L2	2.2 μ H	Inductor, 22.1m Ω , 5.8A	SMD	Coilcraft	XEL4030-222MEB
4	R1, R5, R7, R2	100k Ω	Film resistor, 1%	0603	Yageo	RC0603FR-07100KL
1	R3	48.7k Ω	Film resistor, 1%	0603	Yageo	RC0603FR-0748K7L
1	R4	0 Ω	Film resistor, 5%	0603	Yageo	RC0603JR-070RL
1	R6	31.6k Ω	Film resistor, 1%	0603	Yageo	RC0603FR-0731K6L
1	R8	47.5k Ω	Film resistor, 1%	0603	Yageo	RC0603FR-0747K5L
1	R9	10.2k Ω	Film resistor, 1%	0603	Yageo	RC0603FR-0710K2L
3	J1, J2, JP3	2.54mm	Test pin, 3-pin	DIP	Any	
4	VEMI, GND, VOUT, GND	2mm	Golden pin	DIP	Custom ⁽¹⁾	
5	SYNCIN, GND, PG, EN, GND	1mm	Golden pin	DIP	Custom ⁽¹⁾	
1	U1	MPQ4334 -4000- AEC1	4A, low-I _Q , synchronous step-down converter, AEC- Q100 qualified	QFN-12 (2mmx 3mm)	MPS	MPQ4334GDE-4000- AEC1

Note:

1) MPS custom-produces these pins. Contact an MPS FAE for more information.

EVB TEST RESULTS

Performance curves and waveforms are tested on the evaluation board, $V_{IN} = 12V$, $V_{OUT} = 5V$, $T_A = 25^\circ C$, unless otherwise noted.

Input Current vs. Load Current for 4000 Version

$R_{FB1} = 100k\Omega$, $R_{FB2} = 19.1k\Omega$,
DCR = 22.1m Ω

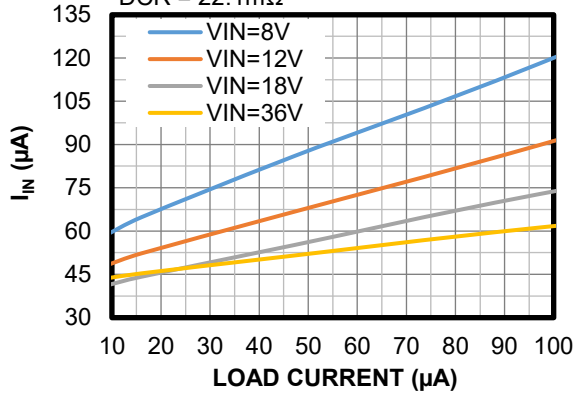

Efficiency vs. Load Current for 4000 Version

$R_{FB1} = 100k\Omega$, $R_{FB2} = 19.1k\Omega$,
DCR = 22.1m Ω

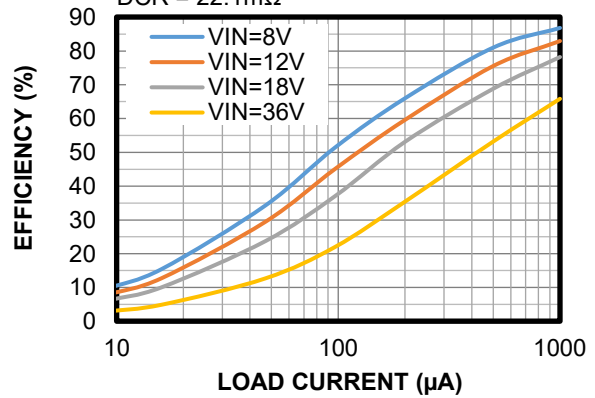

Efficiency vs. Load Current for 4000 Version

DCR = 22.1m Ω

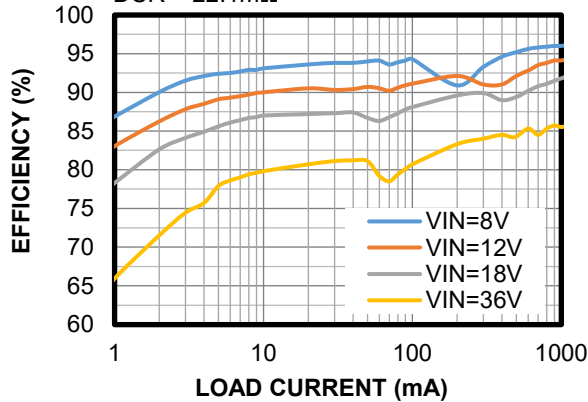

Efficiency vs. Load Current for 4000 Version

DCR = 22.1m Ω

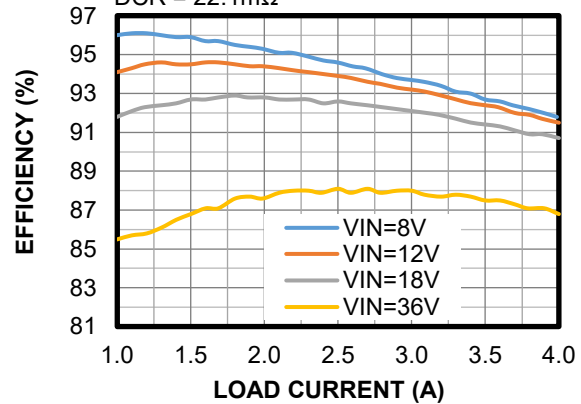

Load Regulation for 4000 Version

DCR = 22.1m Ω

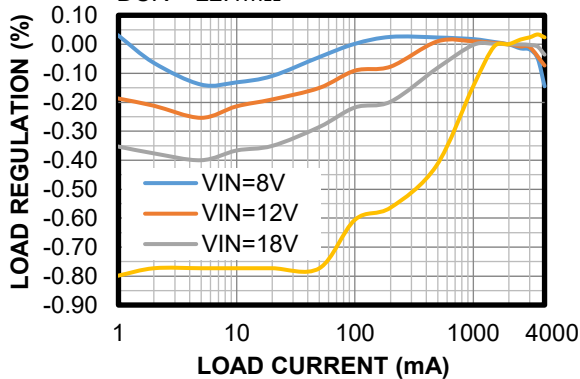

Line Regulation for 4000 Version

DCR = 22.1m Ω

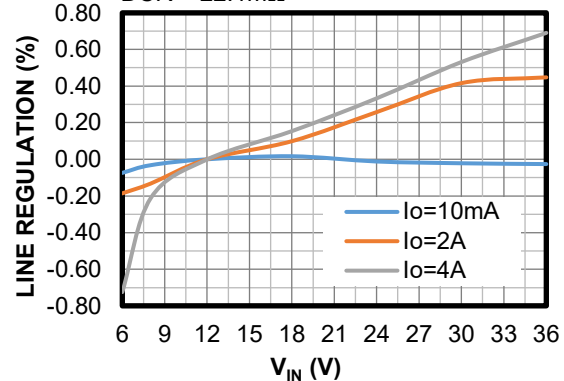

EVb TEST RESULTS (continued)

Performance curves and waveforms are tested on the evaluation board, $V_{IN} = 12V$, $V_{OUT} = 5V$, $T_A = 25^\circ C$, unless otherwise noted.

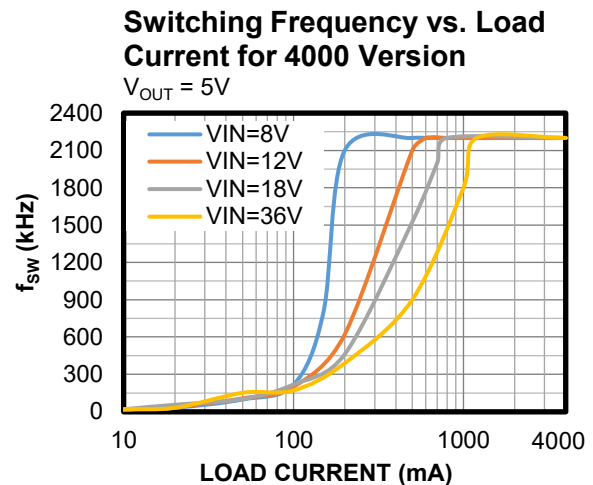
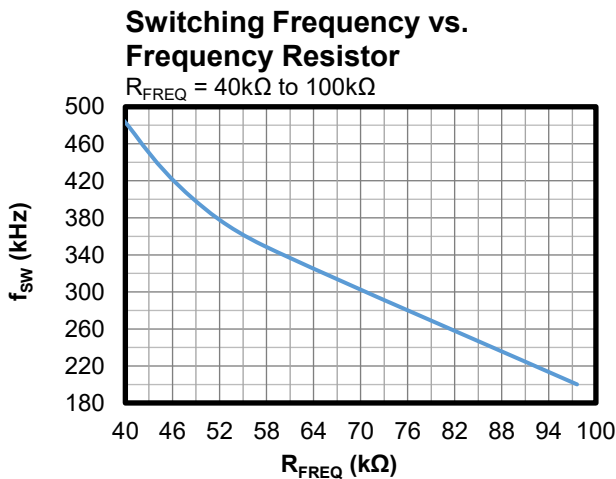
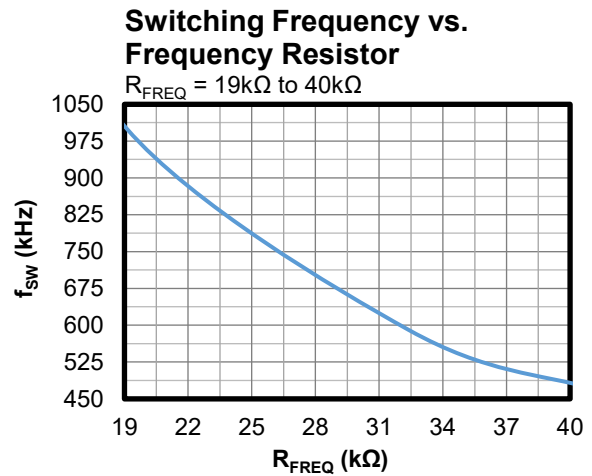
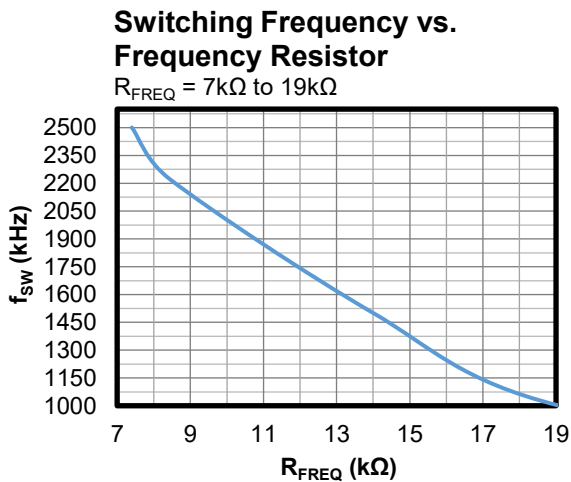
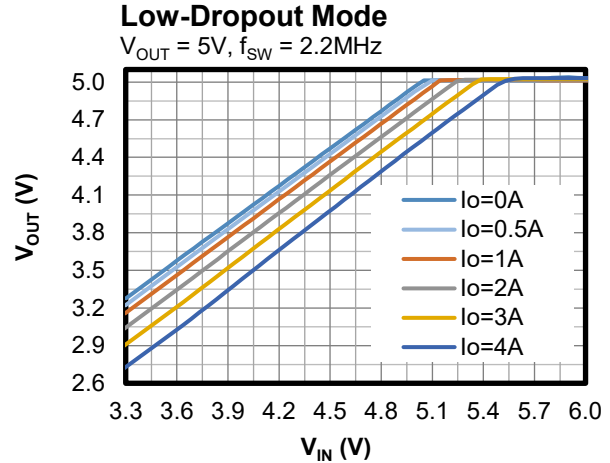
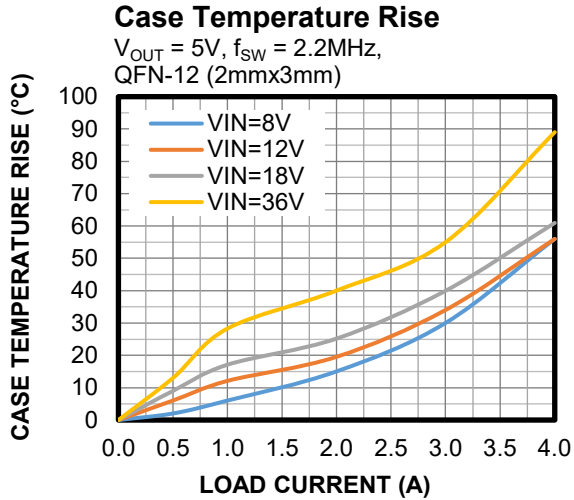

EVB TEST RESULTS (continued)

Performance curves and waveforms are tested on the evaluation board, $V_{IN} = 12V$, $V_{OUT} = 5V$, $T_A = 25^{\circ}C$, unless otherwise noted.

Thermal Performance

$I_{OUT} = 2A$, no forced airflow, $T_{CASE} = 41^{\circ}C$

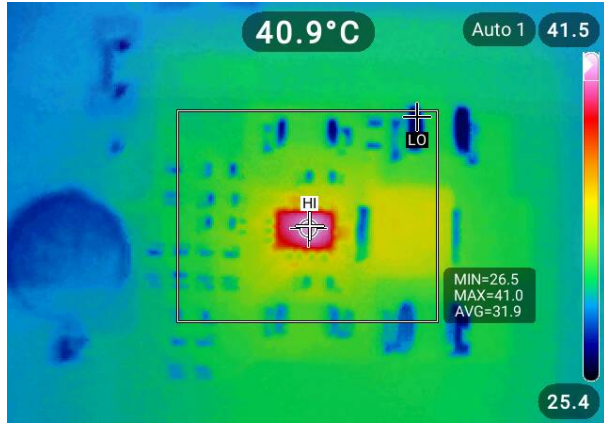

Thermal Performance

$I_{OUT} = 4A$, no forced airflow, $T_{CASE} = 80.8^{\circ}C$

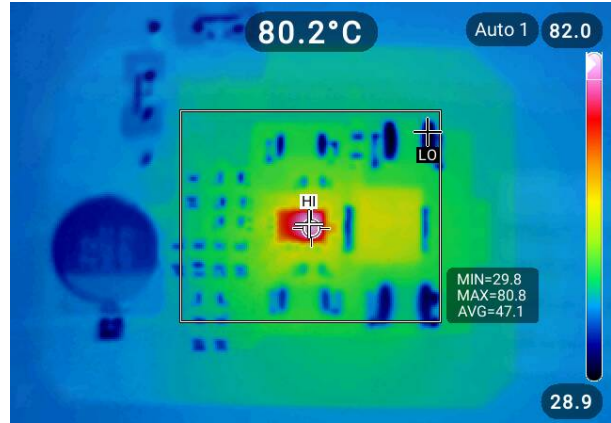

Bode Plot

$I_{OUT} = 1A$, $PM = 66.8^{\circ}$, $GM = 14.4dB$

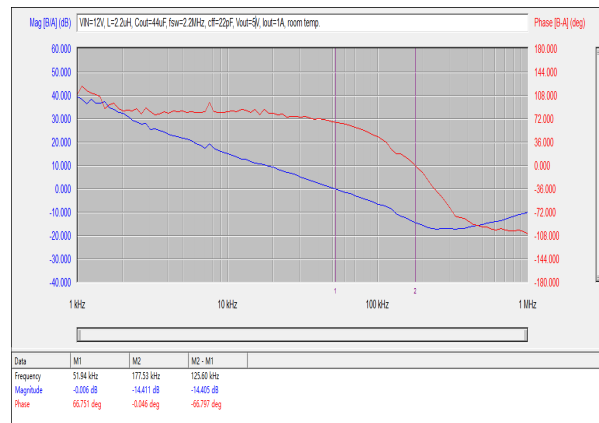

Bode Plot

$I_{OUT} = 4A$, $PM = 71.7^{\circ}$, $GM = 16.8dB$

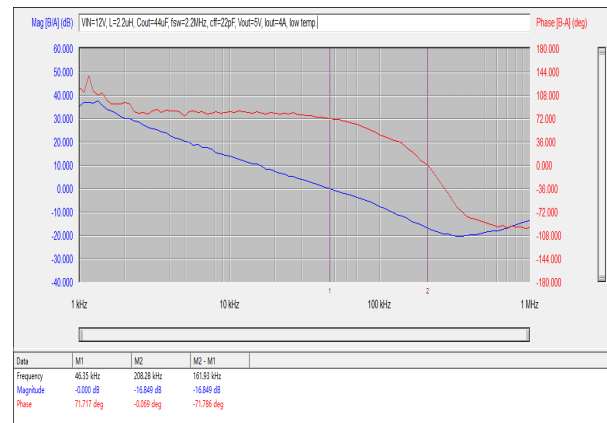

EVB TEST RESULTS (continued)

Performance curves and waveforms are tested on the evaluation board, $V_{IN} = 12V$, $V_{OUT} = 5V$, $T_A = 25^\circ C$, unless otherwise noted.

CISPR 25 Class 5 Peak Conducted Emissions

150kHz to 108MHz

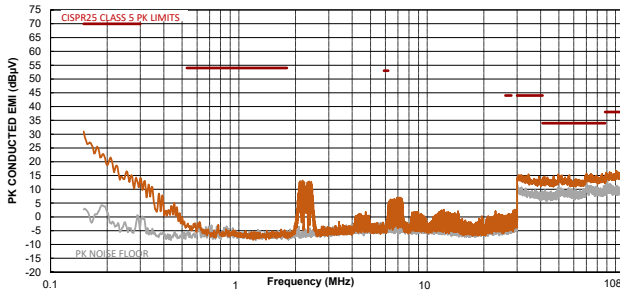

CISPR 25 Class 5 Average Conducted Emissions

150kHz to 108MHz

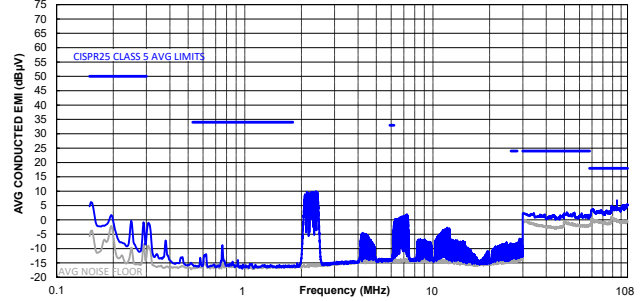

CISPR 25 Class 5 Peak Radiated Emissions

150kHz to 30MHz

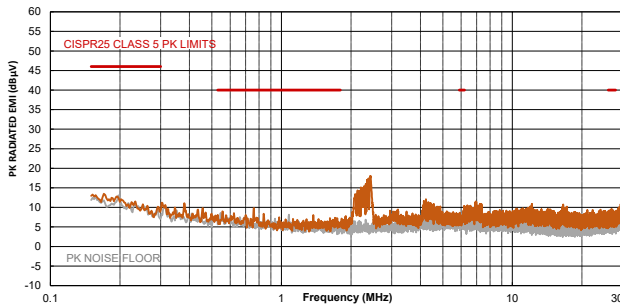

CISPR 25 Class 5 Average Radiated Emissions

150kHz to 30MHz

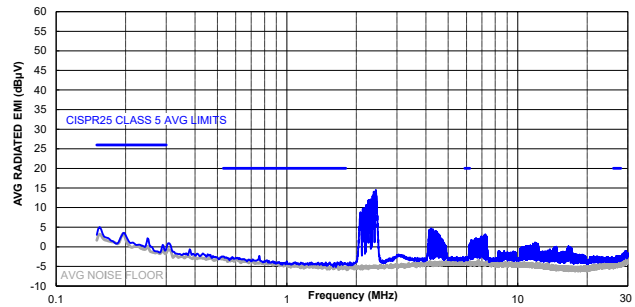

CISPR 25 Class 5 Peak Radiated Emissions

Horizontal, 30MHz to 1GHz

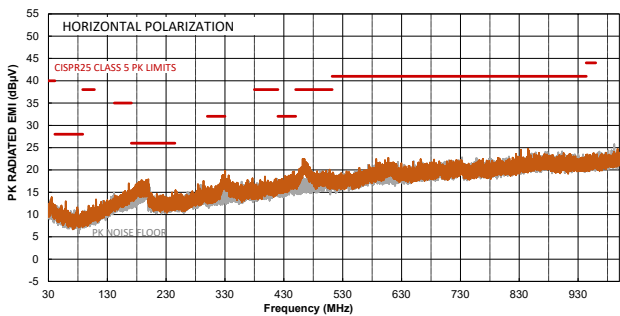

CISPR 25 Class 5 Average Radiated Emissions

Horizontal, 30MHz to 1GHz

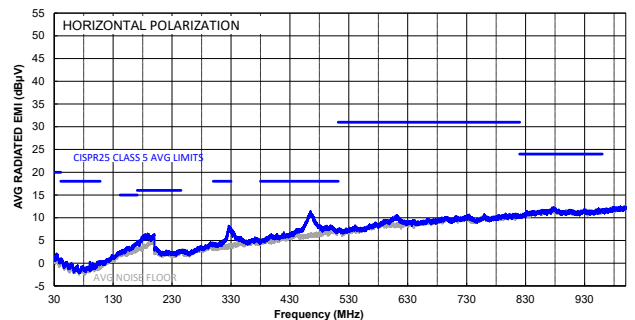

EVB TEST RESULTS *(continued)*

Performance curves and waveforms are tested on the evaluation board, $V_{IN} = 12V$, $V_{OUT} = 5V$, $T_A = 25^{\circ}C$, unless otherwise noted.

CISPR 25 Class 5 Peak Radiated Emissions

Vertical, 30MHz to 1GHz

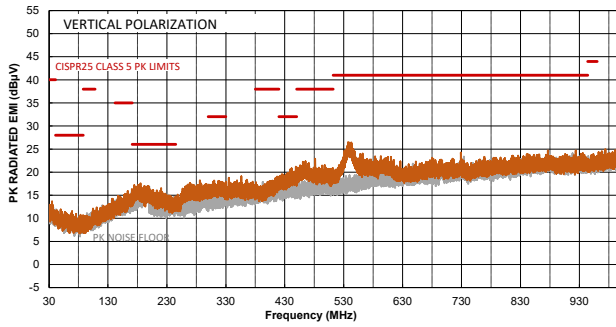

CISPR 25 Class 5 Average Radiated Emissions

Vertical, 30MHz to 1GHz

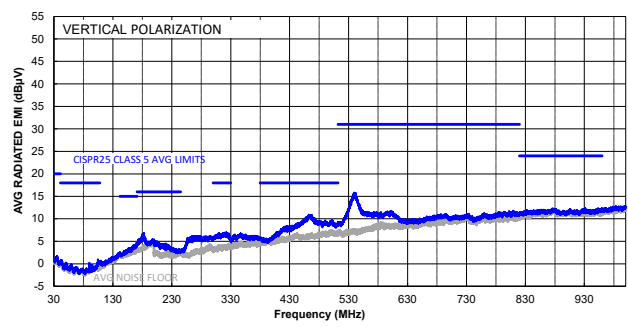

EVB TEST RESULTS (continued)

Performance curves and waveforms are tested on the evaluation board, $V_{IN} = 12V$, $V_{OUT} = 5V$, $T_A = 25^\circ C$, unless otherwise noted.

Steady State

$I_{OUT} = 0A$

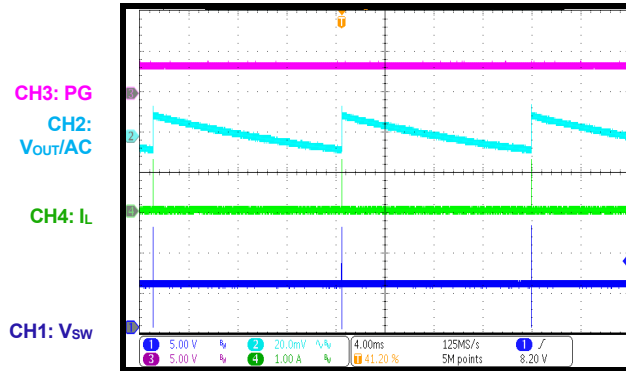

Steady State

$I_{OUT} = 4A$

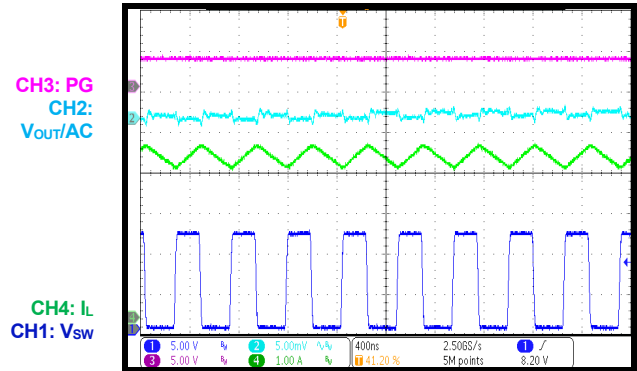

Start-Up through VIN

$I_{OUT} = 0A$

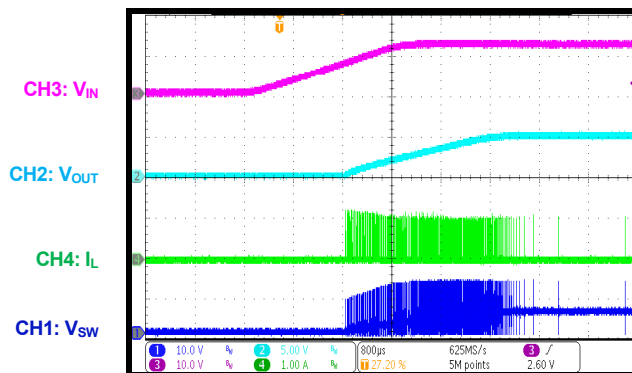

Start-Up through VIN

$I_{OUT} = 4A$

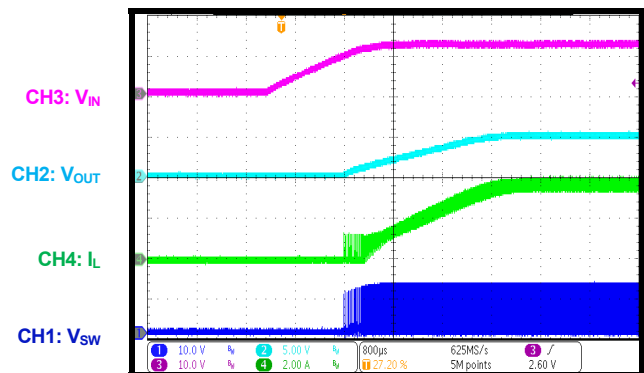

Shutdown through VIN

$I_{OUT} = 0A$

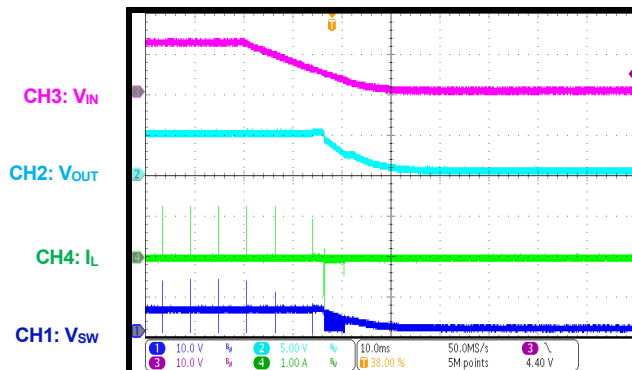

Shutdown through VIN

$I_{OUT} = 4A$

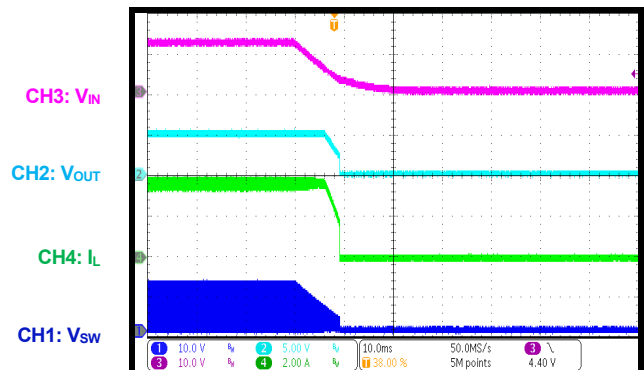

EVB TEST RESULTS (continued)

Performance curves and waveforms are tested on the evaluation board, $V_{IN} = 12V$, $V_{OUT} = 5V$, $T_A = 25^\circ C$, unless otherwise noted.

Start-Up through EN
 $I_{OUT} = 0A$

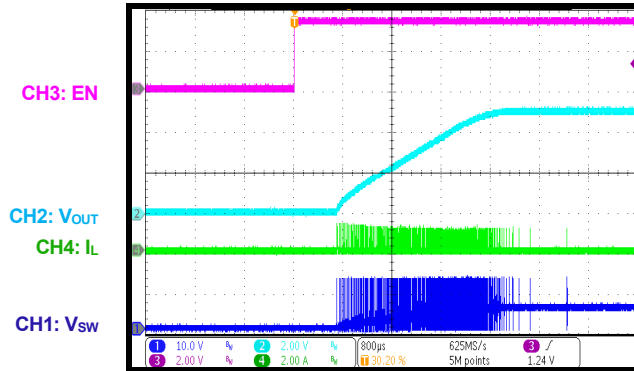

Start-Up through EN
 $I_{OUT} = 4A$

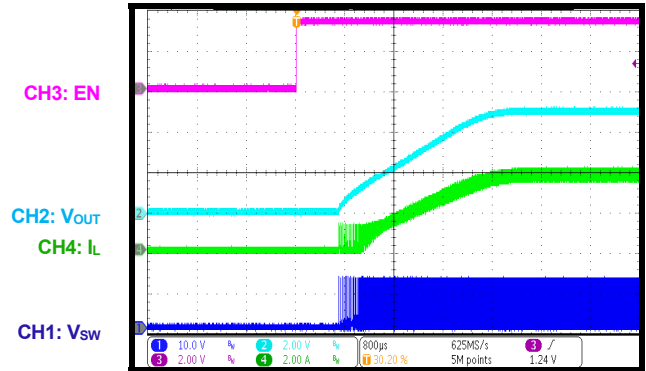

Shutdown through EN
 $I_{OUT} = 0A$

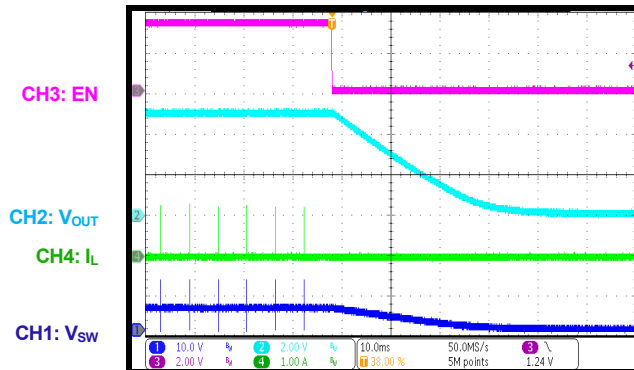

Shutdown through EN
 $I_{OUT} = 4A$

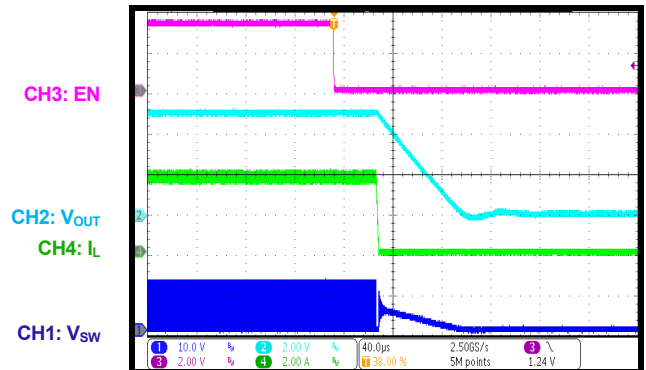

PG Start-Up through VIN
 $I_{OUT} = 0A$

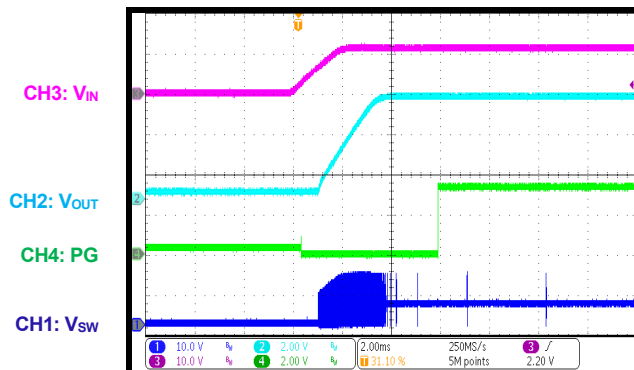

PG Start-Up through VIN
 $I_{OUT} = 4A$

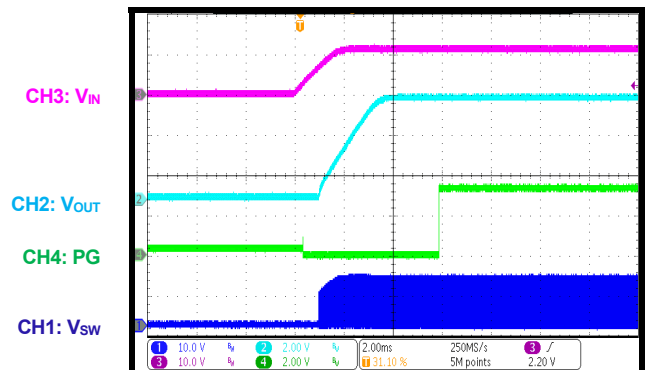

EVB TEST RESULTS (continued)

Performance curves and waveforms are tested on the evaluation board, $V_{IN} = 12V$, $V_{OUT} = 5V$, $T_A = 25^\circ C$, unless otherwise noted.

PG Shutdown through VIN

$I_{OUT} = 0A$

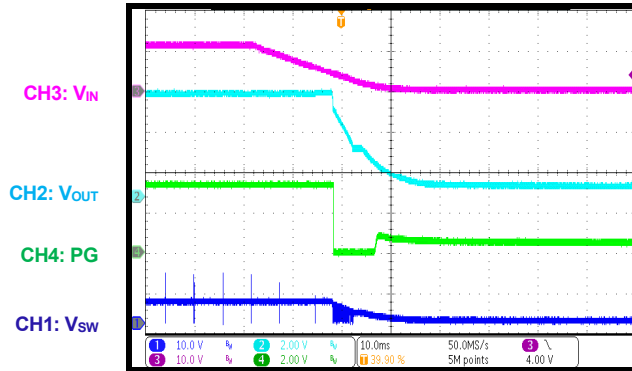

PG Shutdown through VIN

$I_{OUT} = 4A$

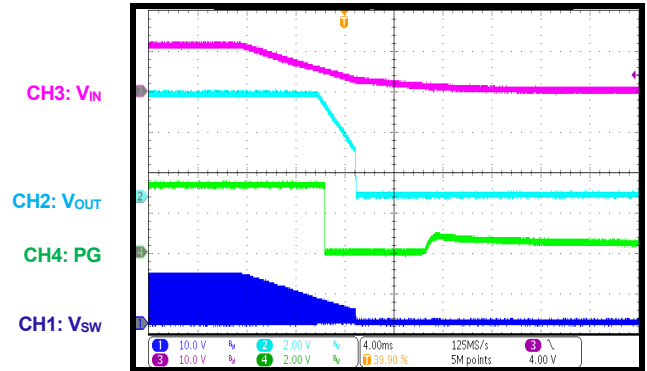

PG Start-Up through EN

$I_{OUT} = 0A$

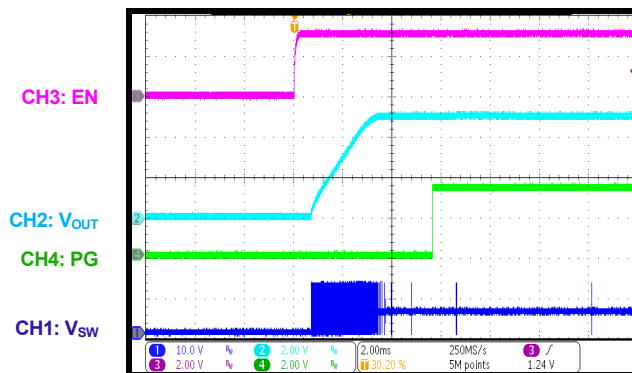

PG Start-Up through EN

$I_{OUT} = 4A$

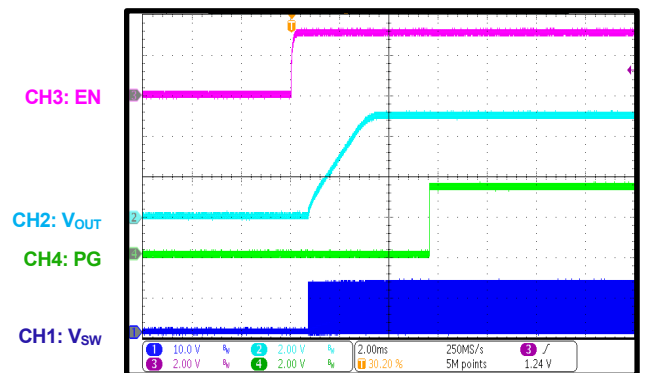

PG Shutdown through EN

$I_{OUT} = 0A$

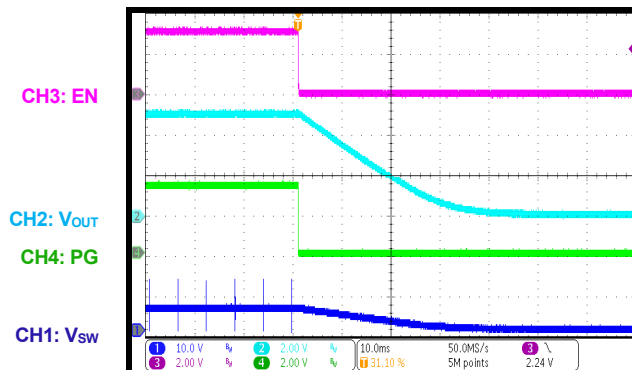

PG Shutdown through EN

$I_{OUT} = 4A$

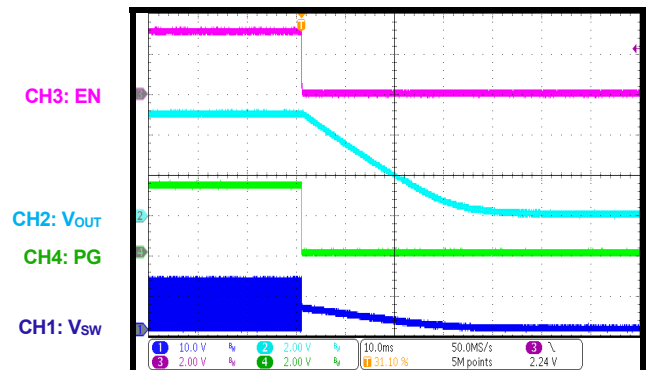

EVB TEST RESULTS (continued)

Performance curves and waveforms are tested on the evaluation board, $V_{IN} = 12V$, $V_{OUT} = 5V$, $T_A = 25^\circ C$, unless otherwise noted.

Low-Dropout Mode

$I_{OUT} = 0A$, $V_{IN} = 3.3V$

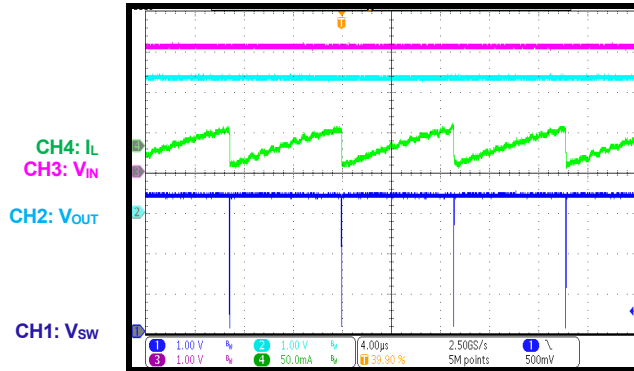

Low-Dropout Mode

$I_{OUT} = 4A$, $V_{IN} = 3.3V$

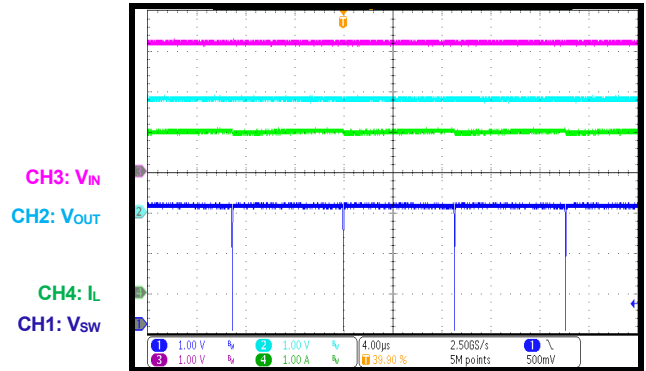

SCP Entry

$I_{OUT} = 0A$

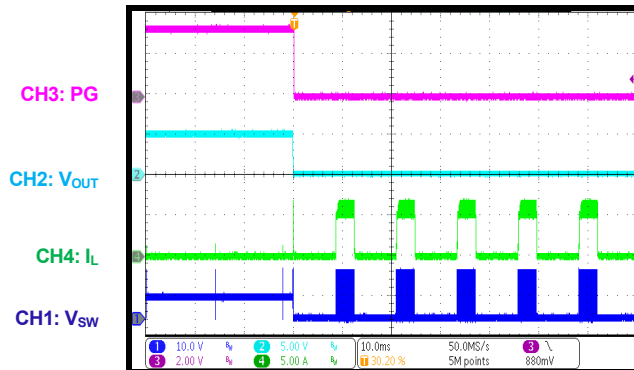

SCP Entry

$I_{OUT} = 4A$

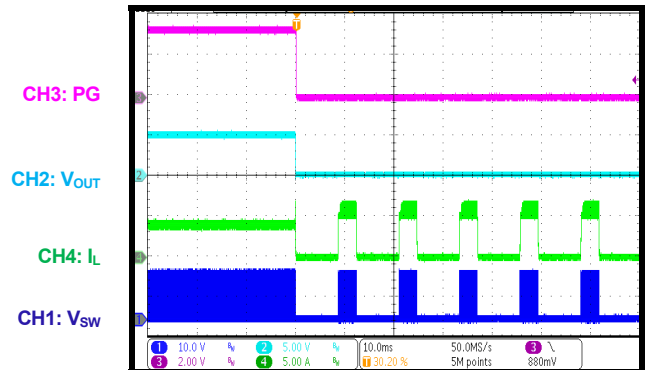

SCP Recovery

$I_{OUT} = 0A$

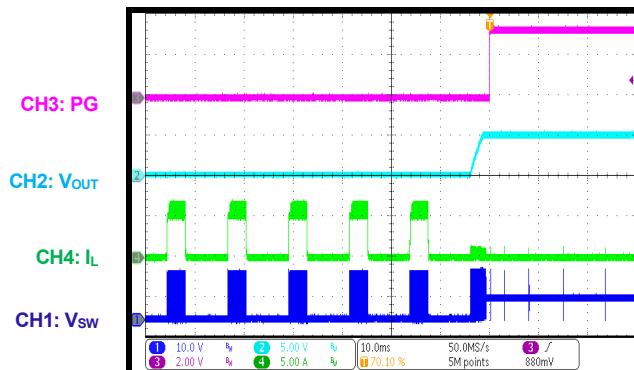

SCP Recovery

$I_{OUT} = 4A$

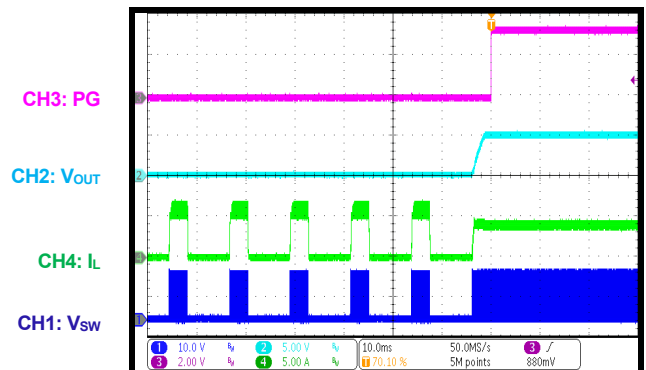

EVB TEST RESULTS (continued)

Performance curves and waveforms are tested on the evaluation board, $V_{IN} = 12V$, $V_{OUT} = 5V$, $T_A = 25^\circ C$, unless otherwise noted.

SCP Steady State

$I_{OUT} = 0A$

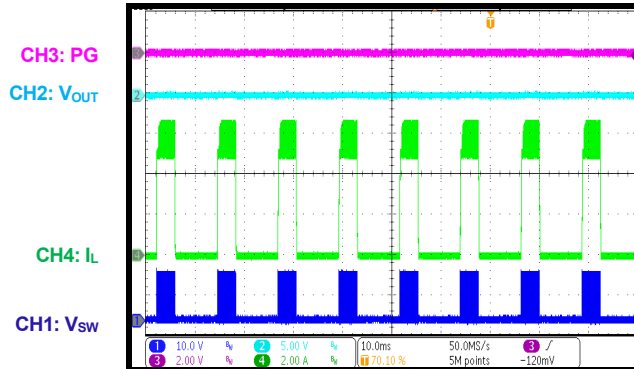

Load Transient

$I_{OUT} = 2A$ to $4A$, $1.6A/\mu s$

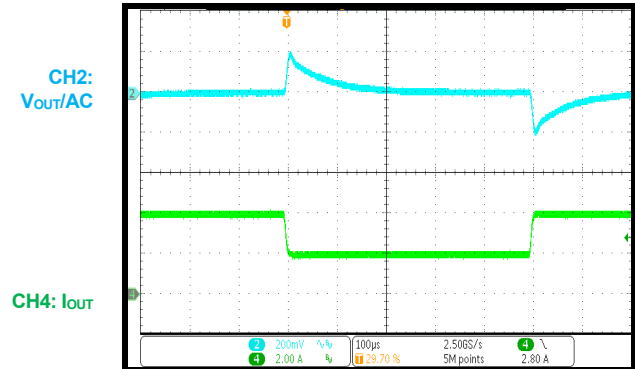

Load Dump

$V_{IN} = 12V$ to $40V$, $I_{OUT} = 0A$

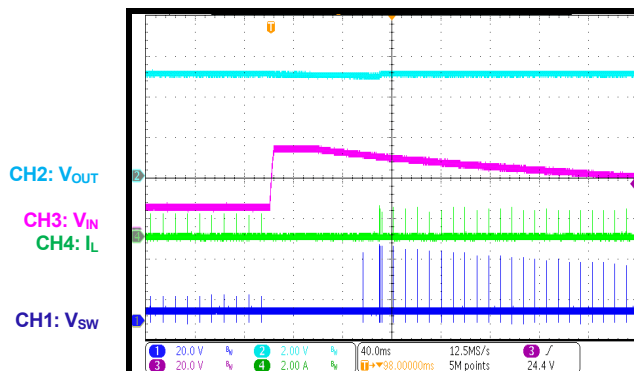

Load Dump

$V_{IN} = 12V$ to $40V$, $I_{OUT} = 4A$

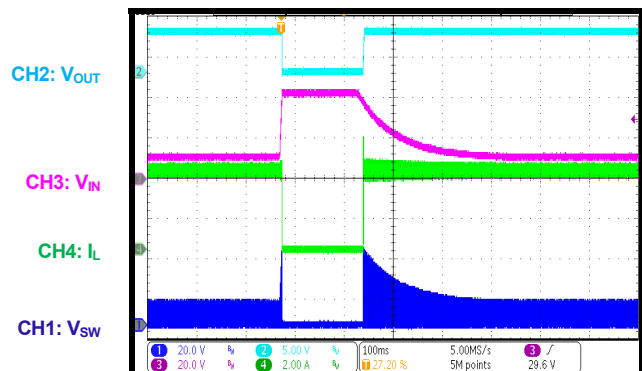

Cold Crank

$I_{OUT} = 0A$

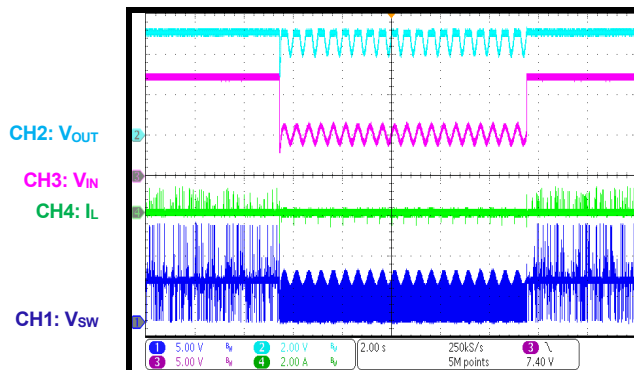

Cold Crank

$I_{OUT} = 4A$

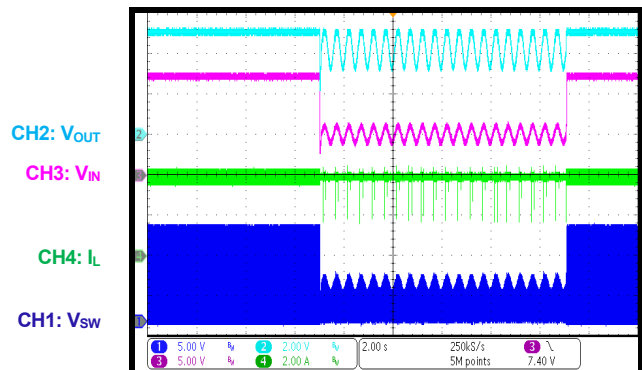

EVB TEST RESULTS *(continued)*

Performance curves and waveforms are tested on the evaluation board. $V_{IN} = 12V$, $V_{OUT} = 5V$, $T_A = 25^\circ C$, unless otherwise noted.

V_{IN} Ramping Down and Up
 $V_{IN} = 6V$ to $0V$, $0.5V/min$, $I_{OUT} = 0A$

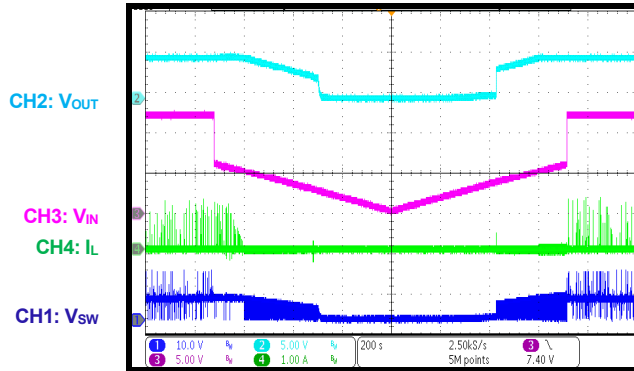

V_{IN} Ramping Down and Up
 $V_{IN} = 6V$ to $0V$, $0.5V/min$, $I_{OUT} = 4A$

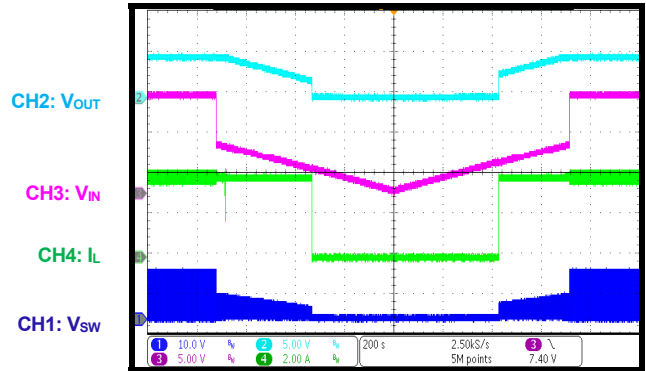

PCB LAYOUT (2)

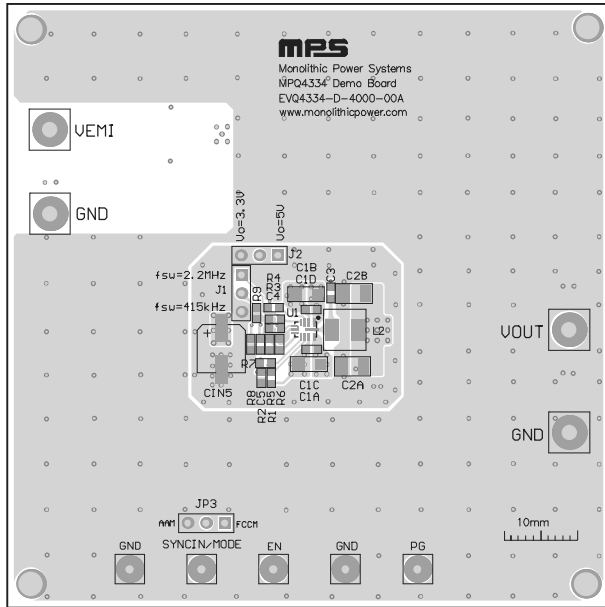

Figure 4: Top Silk and Top Layer

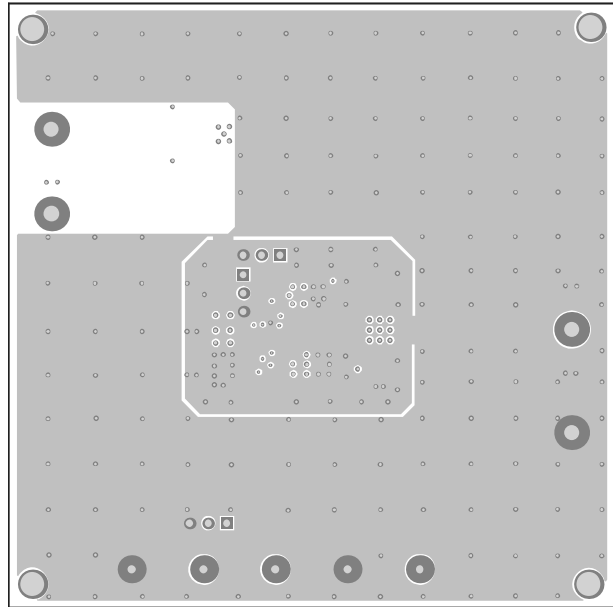

Figure 5: Mid-Layer 1

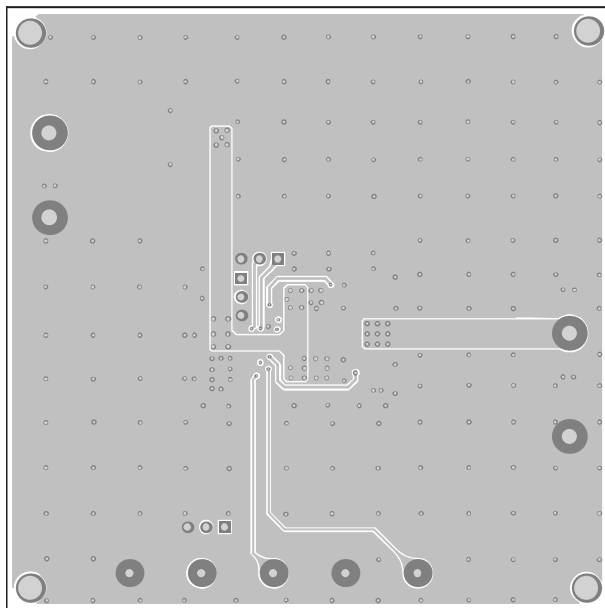

Figure 6: Mid-Layer 2

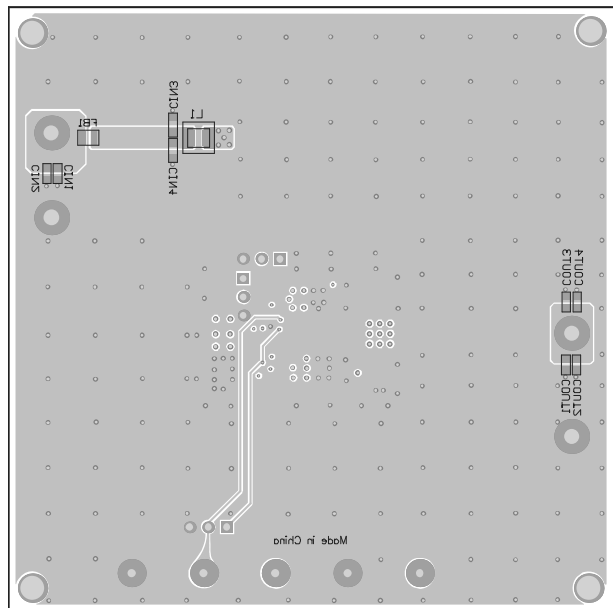

Figure 7: Bottom Layer and Bottom Silk

Note:

2) The copper thickness is 2oz.

REVISION HISTORY

Revision #	Revision Date	Description	Pages Updated
1.0	5/29/2025	Initial Release	-

Notice: The information in this document is subject to change without notice. Please contact MPS for current specifications. Users should warrant and guarantee that third-party Intellectual Property rights are not infringed upon when integrating MPS products into any application. MPS will not assume any legal responsibility for any said applications.