



The Future of Analog IC Technology®

EVQ2735-G-00A

Low-Voltage 0.45Ω Dual SPDT Analog Switches

DESCRIPTION

The MPQ2735 are low voltage, low on-resistance, dual single-pole/double-throw (SPDT) monolithic CMOS analog switches designed for high performance switching of analog signals. Combining low-power, high speed, low on-resistance, and small package size, the MPQ2735 are ideal for portable and battery power applications.

The MPQ2735 have an operation range from 1.65V to 5.5V single supply. The MP2735 has two separate control pins and two separate SPDT switches. All switches are at high impedance mode when the EN is high.

The MPQ2735 are guaranteed 1.65V logic compatible, allowing the easy interface with low voltage DSP or MCU control logic and ideal for one cell Li-ion battery direct power.

ELECTRICAL SPECIFICATIONS

Parameter	Symbol	Value	Units
Input Supply Voltage	V+	1.65 – 5.5	V
Analog Signal Voltage	V _{ANALOG}	0 – V+	V
Output Current (Max)	I _{OUT_MAX}	300	mA

FEATURES

- Low Voltage Operation (1.65V to 5.5V)
- Low On-Resistance - R_{ON}: 0.45Ω at 2.7V
- Fast Switching: T_{ON} = 29ns at 2.7V
- T_{OFF} = 23ns at 2.7V
- Latch-Up Current >300mA (JESD78)
- 1.4mm x 1.8mm FCQFN10 Package
- ESD Human-Body Model ±4000V

APPLICATIONS

- Cellular Phones
- Speaker Headset Switching
- Audio and Video Signal Routing
- PCMCIA Cards
- Battery Powered Systems
- Portable Media Player
- Handheld Test Instruments

All MPS parts are lead-free, halogen free, and adhere to the RoHS directive. For MPS green status, please visit MPS website under Quality Assurance.
 "MPS" and "The Future of Analog IC Technology" are Registered Trademarks of Monolithic Power Systems, Inc.

EVQ2735-G-00A EVALUATION BOARD



Board Number	MPS IC Number
EVQ2735-G-00A	MPQ2735-G

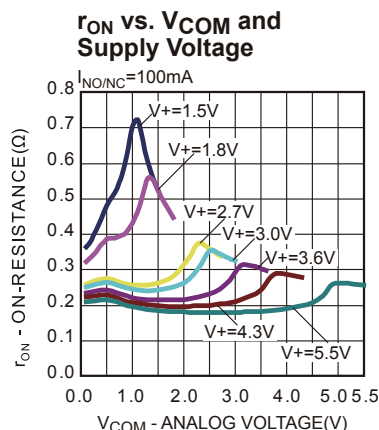

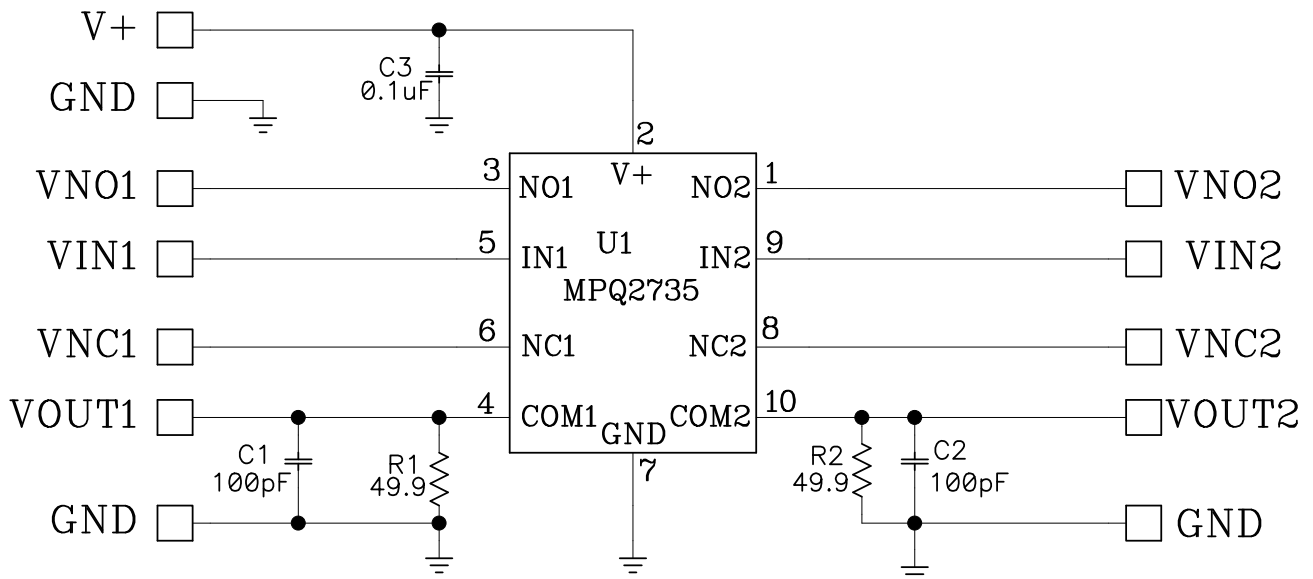
EVALUATION BOARD SCHEMATIC

EVALUATION BOARD SCHEMATIC BILL OF MATERIALS

Qty	Ref Des	Value	Description	Package	Manufacturer	Manufacturer P/N
2	C1, C2	100pF	Ceramic Cap., 50V, C0G, 5%	0603	Generic	
1	C3	0.1µF	Ceramic Cap., 25V, 10%, X7R	0603	Generic	
2	R1, R2	49.9Ω	RES SMD 1% 1/4W	1206	Generic	
1	U1	MPQ2735	Analog Switches	QFN10(2X2mm)	MPS	MPQ2735GG
12	V+, VNO1, VIN1, VNC1, VOUT1, VNO2, VIN2, VNC2, VOUT2, GND, GND1, GND2	Test Point	Test Point	1x2.54mm	HZ	China market

PRINTED CIRCUIT BOARD LAYOUT

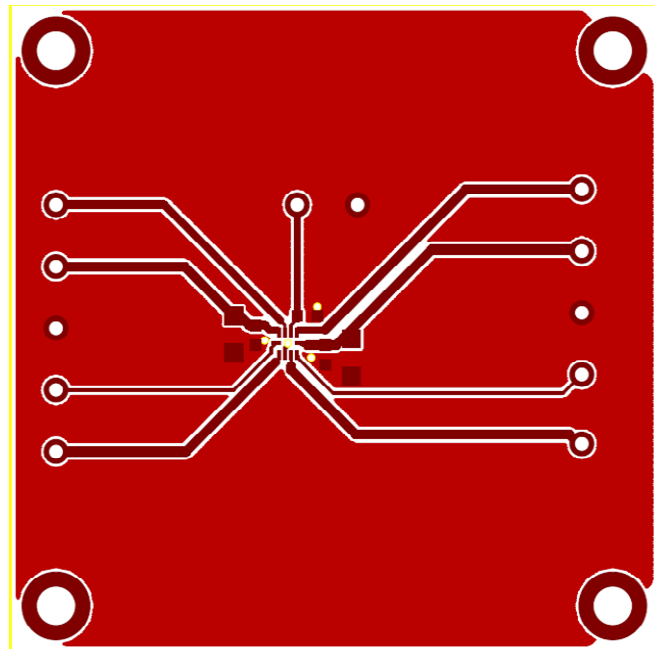
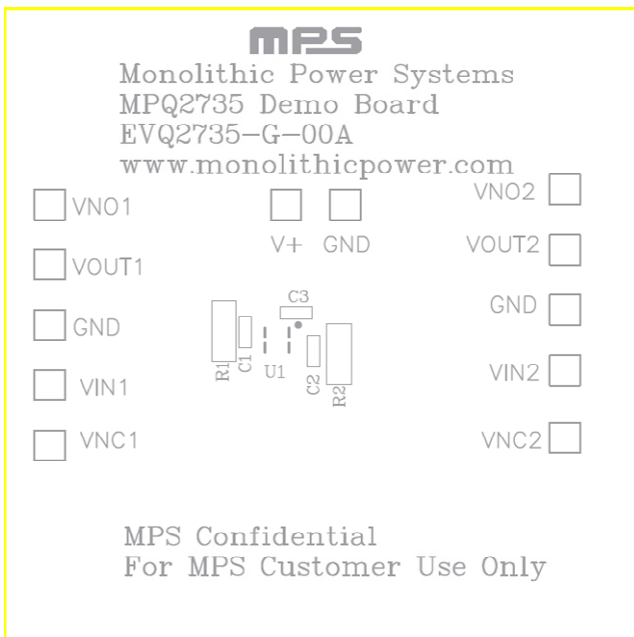

Figure 1—Top Silk Layer

Figure 2—Top Layer

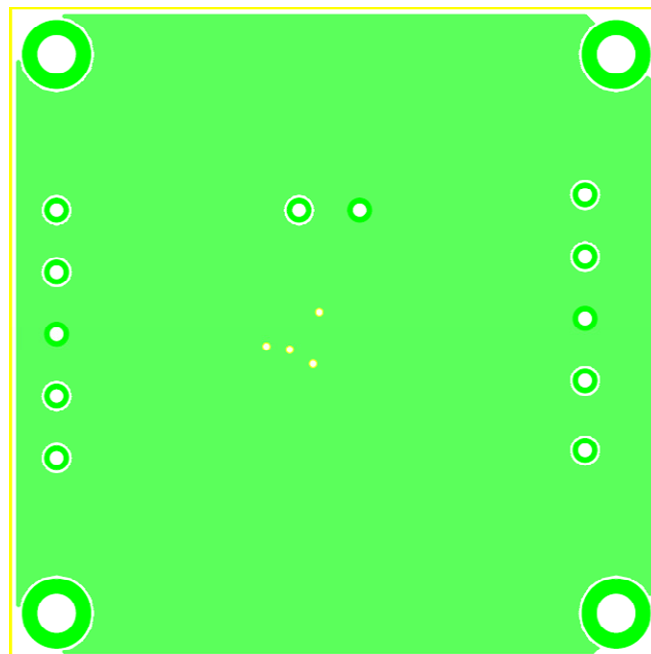

Figure 3—Bottom Layer

QUICK START GUIDE

1. Preset the power supply output to between 1.65V and 5.5V, then turn off the power supply.
2. Connect the positive and negative terminals of the power supply output to the V+ and GND pins, respectively.
3. Turn the power supply on. The NC1 and NC2 channels will automatically turn on. NO1 and NO2 channels are open.
4. Drive IN1 or IN2 higher than 2.5V to turn on NO1 or NO2 channels respectively. Or drive IN1 or IN2 less than 0.4V to turn on NC1 or NC2 channels.

NOTICE: The information in this document is subject to change without notice. Users should warrant and guarantee that third party Intellectual Property rights are not infringed upon when integrating MPS products into any application. MPS will not assume any legal responsibility for any said applications.