



EVQ2287-L-00A

6V, 14A, Configurable, High-Frequency, Synchronous Buck Converter, Evaluation Board, AEC-Q100 Qualified

DESCRIPTION

The EVQ2287-L-00A evaluation board is designed to demonstrate the capabilities of the MPQ2287, a configurable, high-frequency, synchronous buck converter with integrated internal high-side and low-side power MOSFETs (HS-FET and LS-FET, respectively).

The MPQ2287 operates from a 2.7V to 6V input voltage (V_{IN}) range and provides up to 14A of highly efficient output current (I_{OUT}) with fixed-frequency, zero-delay pulse-width modulation (PWM) (ZDP™) control for optimal transient response.

The configurable 2MHz to 4MHz switching frequency (f_{SW}) during forced continuous conduction mode (FCCM) reduces the external inductance and capacitance. Internal feedback (FB) and compensation minimizes the external component count and improves accuracy.

High power conversion efficiency across the wide load range is achieved by scaling down f_{SW} under light-load conditions to reduce f_{SW} and gate driving losses. Full protection features include short-circuit protection (SCP), over-current protection (OCP), input over-voltage protection (OVP), output OVP, and thermal shutdown. These protections provide reliable, fault-tolerant operation.

The digital interface features packet error checking (PEC), and the integrated multi-page one-time programmable (OTP) memory allows for a high degree of configurability.

The EVQ2287-L-00A is a fully assembled and tested evaluation board. The MPQ2287 is available in a QFN-18 (3mmx4mm) package with wettable flanks, and is available in AEC-Q100 Grade 1.

PERFORMANCE SUMMARY

Specifications are at $T_A = 25^\circ\text{C}$, unless otherwise noted.

Parameters	Conditions	Value
Input voltage (V_{IN}) range		2.7V to 6V
Output voltage (V_{OUT})	$V_{IN} = 2.7\text{V to }6\text{V}, I_{OUT} = 0\text{A to }14\text{A}$	0.75V
Maximum output current (I_{OUT})	$V_{IN} = 2.7\text{V to }6\text{V}$	14A
Typical efficiency	$V_{IN} = 5\text{V}, V_{OUT} = 0.75\text{V}, I_{OUT} = 14\text{A}$	80.2%
Peak efficiency	$V_{IN} = 2.7\text{V}, V_{OUT} = 0.75\text{V}, I_{OUT} = 3\text{A}$	90.5%
Switching frequency (f_{sw})		3MHz

EVQ2287-L-00A EVALUATION BOARD

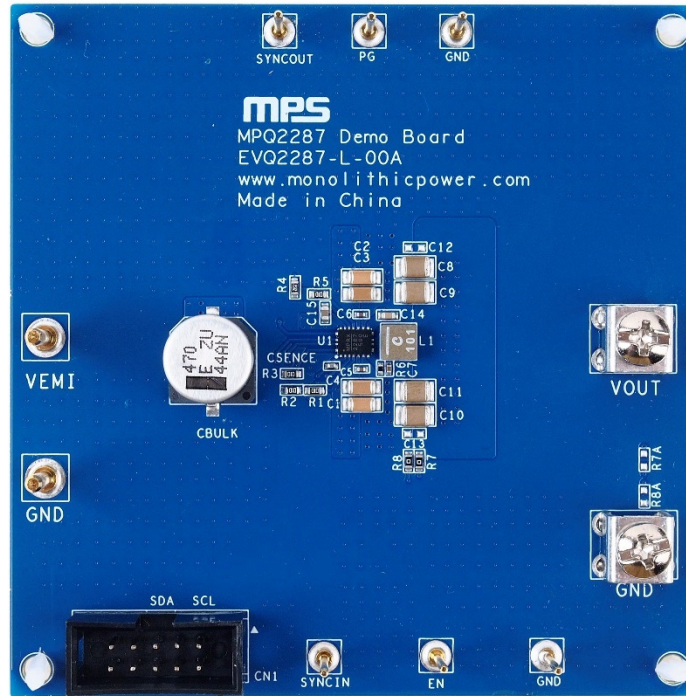

LxWxH (8.3cmx8.3cmx1.3cm)

Board Number	MPS IC Number
EVQ2287-L-00A	MPQ2287GLE-0002-AEC1

QUICK START GUIDE

The EVQ2287-L-00A evaluation board is easy to set up and use to evaluate the MPQ2287's performance. For proper measurement equipment set-up, refer to Figure 2 on page 4 and follow the steps below:

1. Preset the power supply to be between 2.7V and 6V, then turn off the power supply.
2. Set the load current between 0A and 14A. Electronic loads represent a negative impedance to the regulator, and setting the current too high may trigger over-current protection (OCP).
3. If longer cables are used between the source and the evaluation board (>0.5m total), place a damping capacitor at the input terminals.
4. Connect the power supply terminals to:
 - a. Positive (+): VEMI
 - b. Negative (-): GND
5. Connect the load terminals to:
 - a. Positive (+): VOUT
 - b. Negative (-): GND
6. After making the connections, turn on the power supply. The board should start up automatically.
7. To use the enable (EN) function, apply a digital input to the EN pin. Drive EN above 1.2V to turn the regulator on; drive EN below 1.1V to turn it off. If the enable function is not used, EN can be connected to VIN through two resistor dividers. Ensure that the EN voltage (V_{EN}) does not exceed 4V.
8. Evaluate the MPQ2287 with the digital interface by following the steps below:
 - a. Download and install the software Virtual Bench Pro 4.0 (VBP 4.0) from the MPS website. The MPQ2287's graphic user interface (GUI) is embedded in VBP 4.0.
 - b. Connect the EVKT-USBI2C-02 to CN1 with the ribbon cable, and connect the EVKT-USBI2C-02 to the computer with the USB cable. ⁽¹⁾
 - c. Using the MPQ2287's GUI, scan for the evaluation board address, which is 03h by default.
 - d. Evaluate the device with the MPQ2287's GUI, such as the PG delay time and switching frequency (f_{sw}). Figure 1 shows the digital interface evaluation kit set-up.

Note:

- 1) The EVKT-USBI2C-02, which includes the ribbon and USB cables, can be purchased on the MPS website.

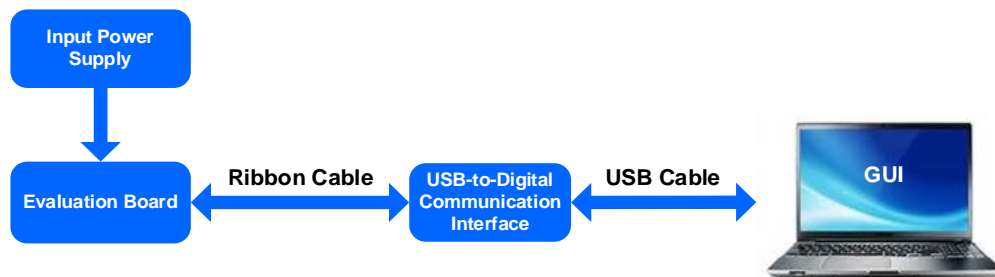

Figure 1: Digital Interface Evaluation Kit Set-Up

9. To use the SYNCIN function, the MPQ2287 operates in FCCM with a fixed frequency, regardless of the output current (I_{OUT}). f_{sw} can be synchronized to the rising edge of an external clock signal applied at SYNCIN. The high amplitude of the synchronous (SYNC) clock should exceed 1.8V, and its low amplitude should be below 0.4V to drive the internal logic. The recommended external SYNC

frequency is $\pm 15\%$ of the set f_{sw} (between 2MHz and 4MHz). A pulse longer than 200ns is recommended.

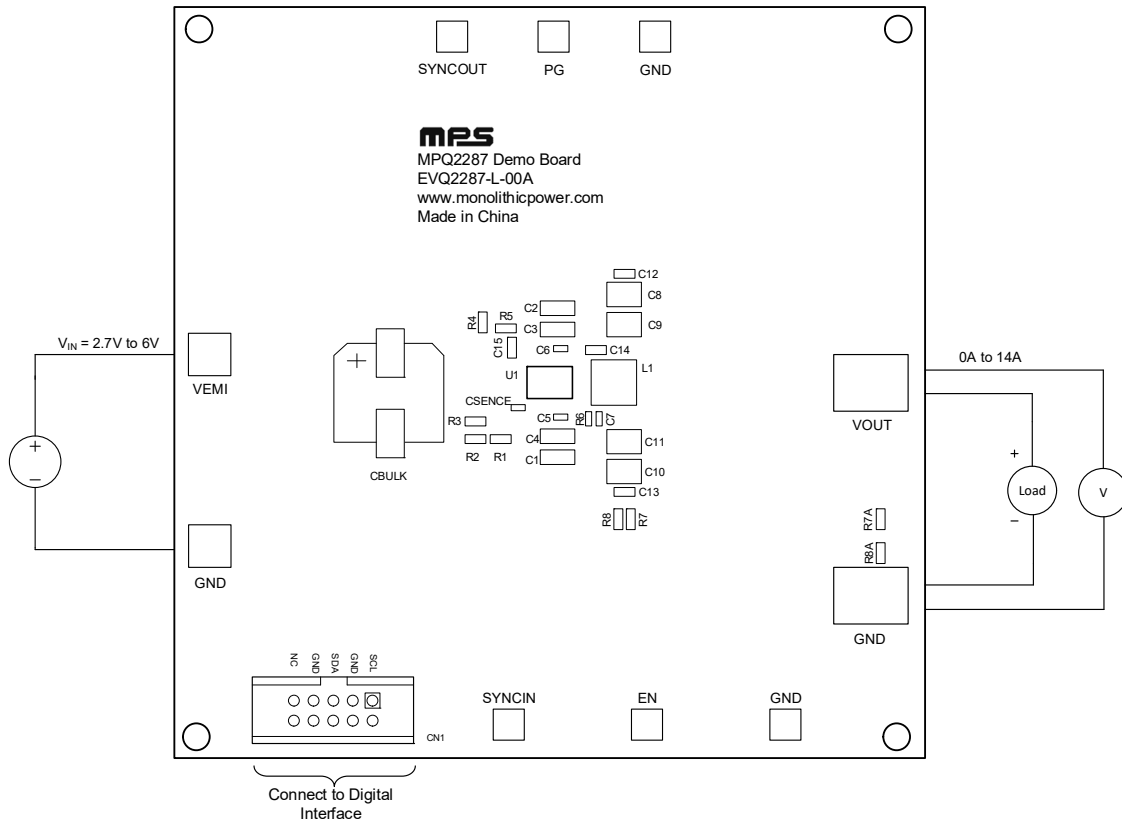

Figure 2: Measurement Equipment Set-Up

MPQ2287GLE-0002-AEC1 DEFAULT REGISTER VALUES

Command Code	Command Name	Type	Bytes	OTP	Value
01h	OPERATION	R/W	1	Yes	80
21h	VOUT_COMMAND	R/W	1	Yes	57
24h	VOUT_MAX	R/W	1	Yes	FF
29h	VOUT_SCALE	R/W	1	Yes	00
2Bh	VOUT_MIN	R/W	1	Yes	00
60h	TON_DELAY	R/W	1	Yes	00
64h	TOFF_DELAY	R/W	1	Yes	00
C5h	HICCUP_TIMER	R/W	1	Yes	01
C6h	VOUT_STARTUP_SLEW	R/W	1	Yes	00
C7h	VOUT_SHUTDOWN_SLEW	R/W	1	Yes	00
C8h	VOUT_SLEW	R/W	1	Yes	00
C9h	OUTPUT_DISCHARGE	R/W	1	Yes	01
CAh	FREQUENCY_DITHER	R/W	1	Yes	01
CBh	FREQUENCY_SET	R/W	1	Yes	06
CCh	COMPENSATION_CONFIG	R/W	2	Yes	0000
CDh	PG_MAPPING	R/W	1	Yes	00
CEh	PROTECTION_CONFIG	R/W	1	Yes	1C
CFh	PG_DELAY	R/W	1	Yes	00
D0h	PG_CONFIG	R/W	1	Yes	01
D1h	LIGHT_LOAD	R/W	1	Yes	01
D2h	ILIM_SCALE	R/W	1	Yes	02
D3h	ADDRESS	R/W	1	Yes	03
D4h	CONFIGURATION_CODE	R	1	Yes	00
D7h	MFR_OTP_MEM_CHK	R/W	1	Yes	00
D9h	SPARE_1	R/W	1	Yes	01
DAh	SPARE_2	R/W	1	Yes	00
DCh	SUMMING_BLOCK_CONFIG	R/W	1	Yes	31
DDh	MIN_ON_CONFIG	R/W	1	Yes	8B

EVALUATION BOARD SCHEMATIC

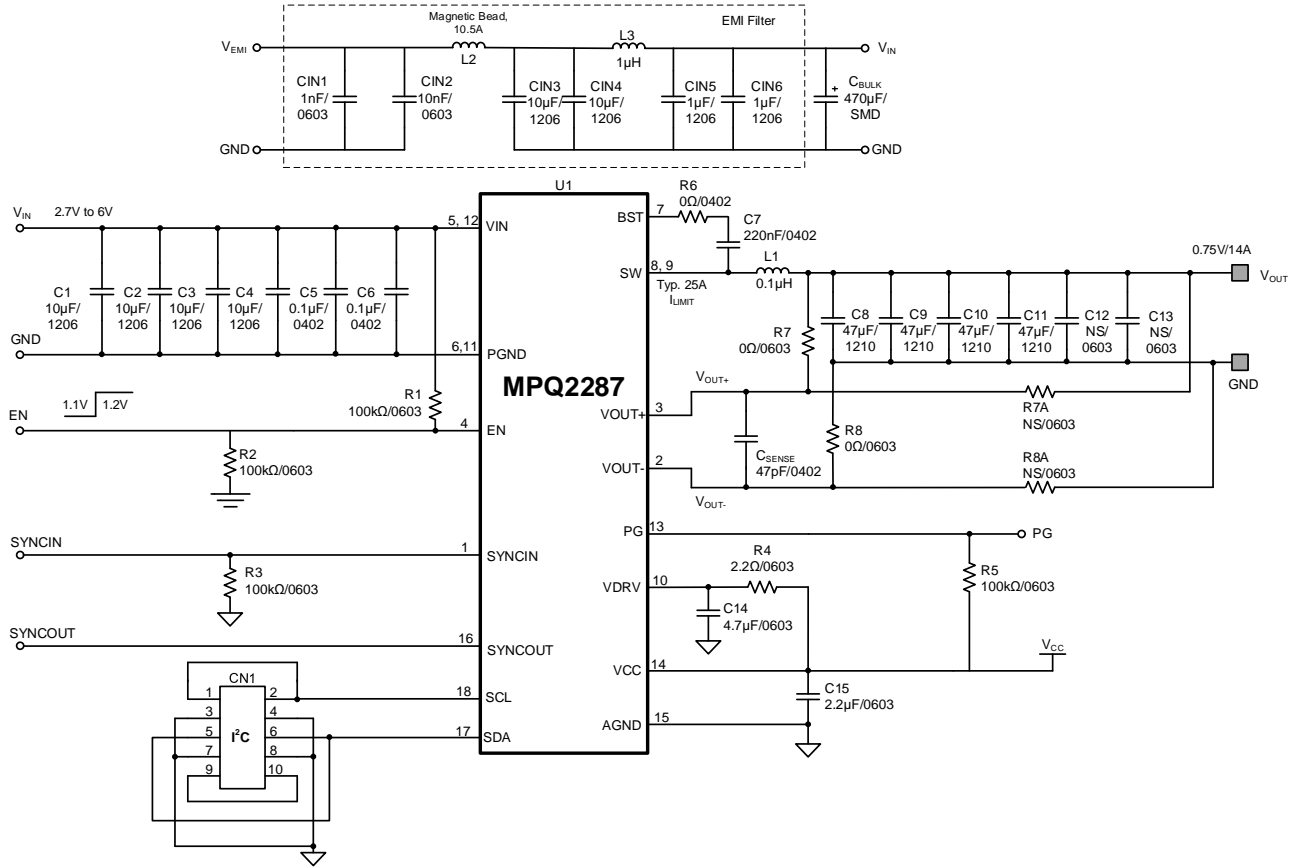
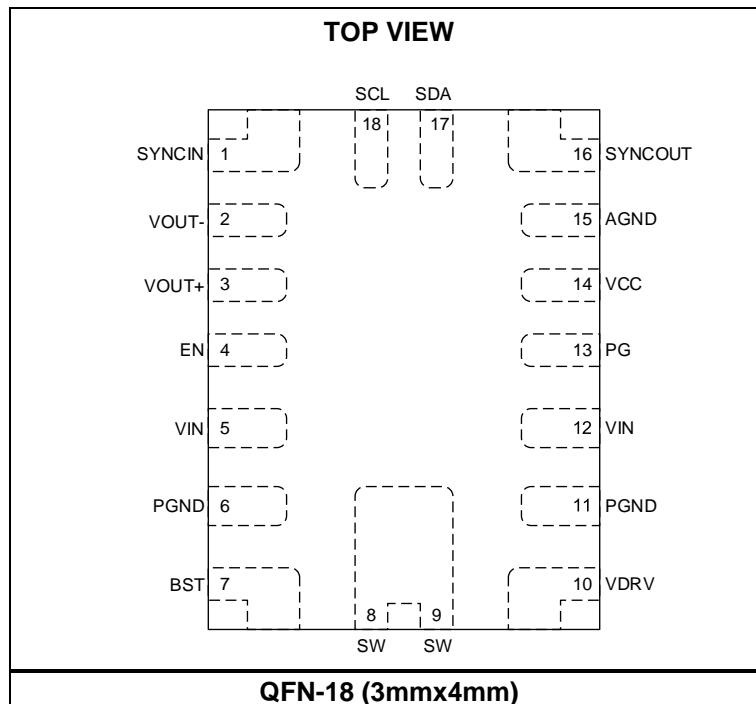

Figure 3: Evaluation Board Schematic

PACKAGE REFERENCE



EVQ2287-L-00A BILL OF MATERIALS

Qty	Ref	Value	Description	Package	Manufacturer	Manufacturer PN
1	CIN1	1nF	Capacitor, 50V, C0G	0603	Murata	GRM1885C1H102JA01D
1	CIN2	10nF	Capacitor, 50V, C0G	0603	Murata	GRM1885C1H103JA01D
6	C1, C2, C3, C4, CIN3, CIN4	10µF	Capacitor, 25V, X7R	1206	Murata	GRM31CR71E106KA12L
2	CIN5, CIN6	1µF	Capacitor, 25V, X7R	1206	Murata	GRM31MR71E105KA01
2	C5, C6	100nF	Capacitor, 16V, X7R	0402	Murata	GCM155R71C104KA55D
1	C7	220nF	Capacitor, 16V, X7R	0402	Murata	GRM155R71C224KA12D
4	C8, C9, C10, C11	47µF	Capacitor, 6.3V, X7R	1210	Murata	GCM32ER70J476KE19L
2	C12, C13	NS				
1	C14	4.7µF	Capacitor, 10V, X5R	0603	Murata	GRM188R61A475KE15D
1	C15	2.2µF	Capacitor, 10V, X7R	0603	Murata	GRM188R71A225KE15D
1	C _{SENSE}	47pF	Capacitor, 50V, C0G	0402	Murata	GRM1555C1H470JA01D
1	C _{BULK}	470µF	Electrolytic capacitor, 25V	SMD	Panasonic	EEHZU1E471P
1	L1	100nH	Inductor, 1.5mΩ, 30A	SMD	Coilcraft	XEL4030-101MEB
1	L2	10.5A	Magnetic bead	1206	Würth	74279221100
1	L3	1µH	Inductor, 13.25mΩ, 9A	SMD	Coilcraft	XEL4020-102MEB
4	R1, R2, R3, R5	100kΩ	Film resistor, 1%	0603	Yageo	RC0603FR-07100KL
1	R4	2.2Ω	Film resistor, 1%	0603	Yageo	RC0603FR-072R2L
1	R6	0Ω	Film resistor, 1%	0402	Yageo	RC0402FR-070RL
2	R7, R8	0Ω	Film resistor, 1%	0603	Yageo	RC0603FR-070RL
2	R7A, R8A	NS				
6	SYNCOUT, SYNCIN, PG, EN, GND, GND	1mm	Golden pin	DIP	Custom ⁽²⁾	
2	VOUT, GND	4 pins	Connector	DIP	Custom ⁽²⁾	8191K-ND
2	VEMI, GND	2mm	Golden pin	DIP	Custom ⁽²⁾	
1	CN1	2.54mm	Dual-row, 5-pin digital interface connector	DIP	Custom ⁽²⁾	
1	U1	MPQ2287- AEC1	6V, 14A, synchronous buck converter, AEC- Q100	QFN-18 (3mmx 4mm)	MPS	MPQ2287GLE-0002- AEC1

Note:

2) MPS custom-produces these pins. Contact an MPS FAE for more information.

EVB TEST RESULTS (continued)

Performance curves and waveforms are tested on the evaluation board. $V_{IN} = 5V$, $V_{OUT} = 0.75V$, $C_{OUT} = 4 \times 47\mu F$, $L = 100nH$, $T_A = 25^\circ C$, unless otherwise noted.

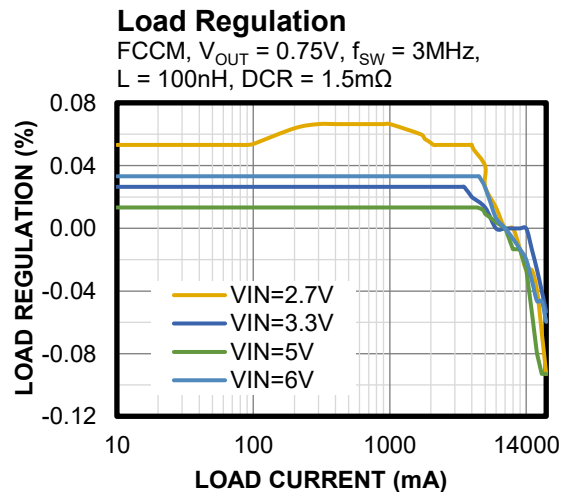
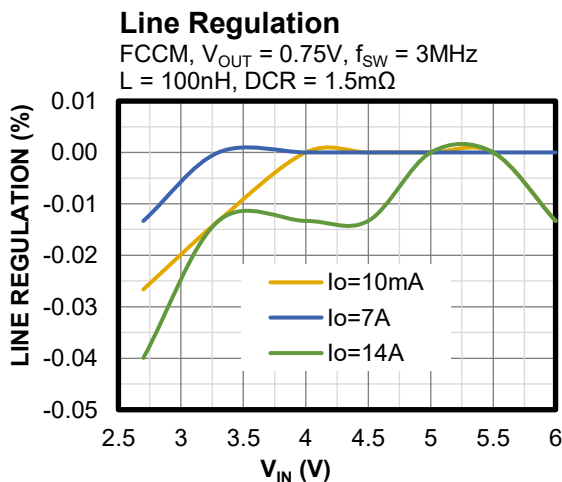
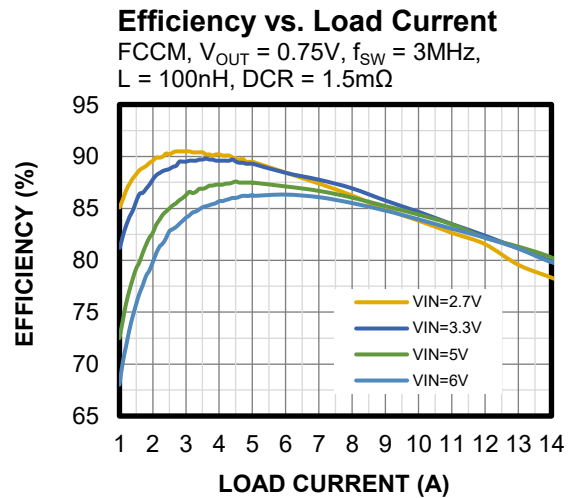
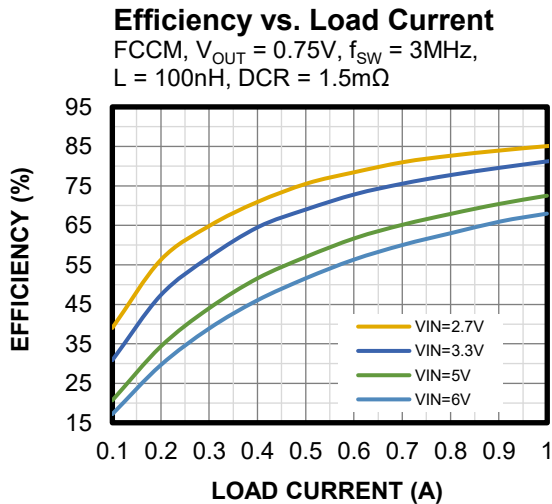
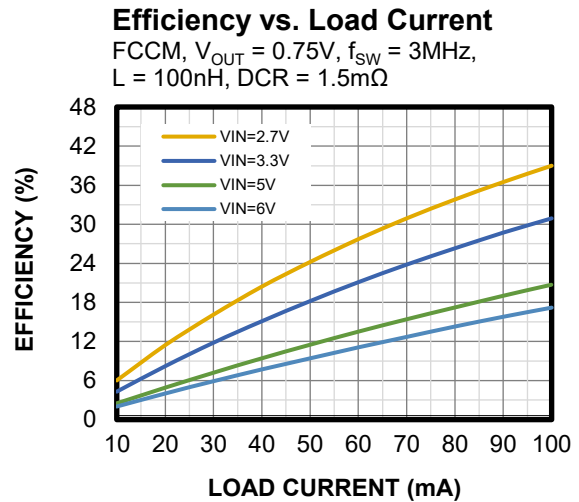
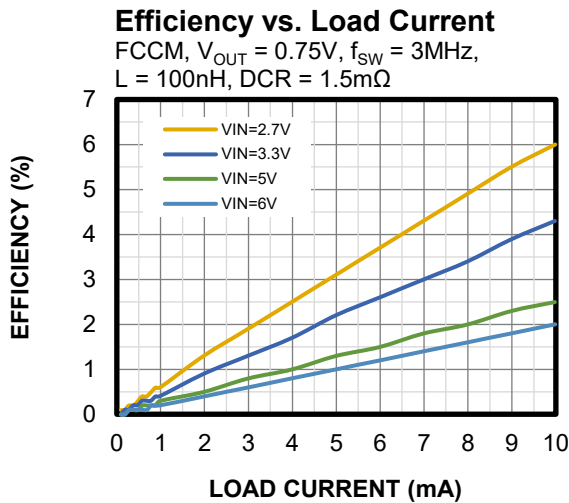

EVB TEST RESULTS *(continued)*

Performance curves and waveforms are tested on the evaluation board. $V_{IN} = 5V$, $V_{OUT} = 0.75V$, $C_{OUT} = 4 \times 47\mu F$, $L = 100nH$, $T_A = 25^\circ C$, unless otherwise noted.

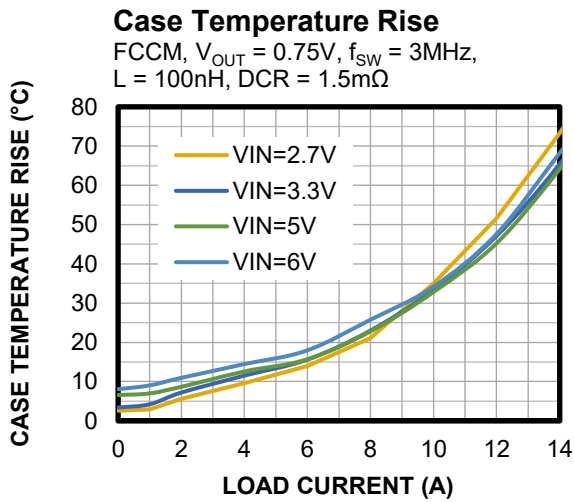

EVB TEST RESULTS (continued)

Performance curves and waveforms are tested on the evaluation board. $V_{IN} = 5V$, $V_{OUT} = 0.75V$, $C_{OUT} = 4 \times 47\mu F$, $L = 100nH$, $T_A = 25^\circ C$, unless otherwise noted.

Thermal Performance

$I_{OUT} = 7A$, no forced airflow, $T_{CASE} = 47.9^\circ C$

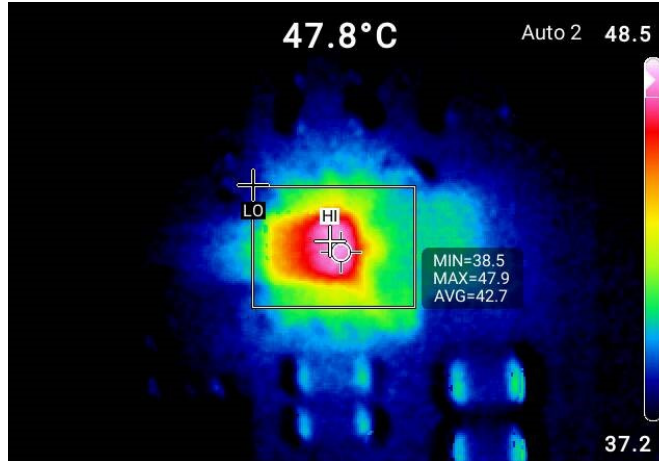

Thermal Performance

$I_{OUT} = 14A$, no forced airflow, $T_{CASE} = 97^\circ C$

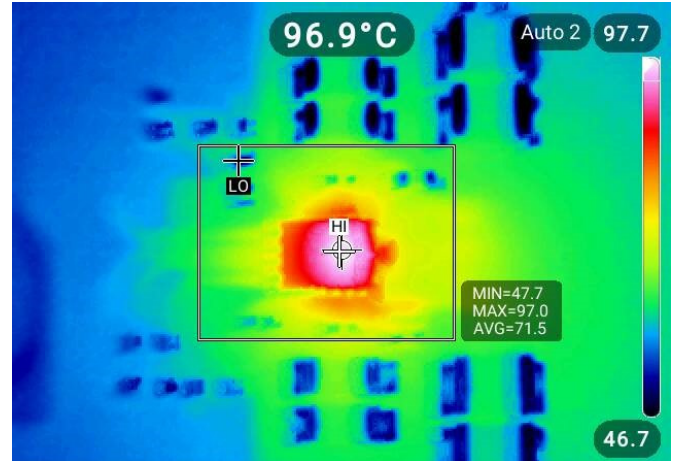

Bode Plot

$I_{OUT} = 0A$, $PM = 59.8^\circ$, $GM = 27.2dB$

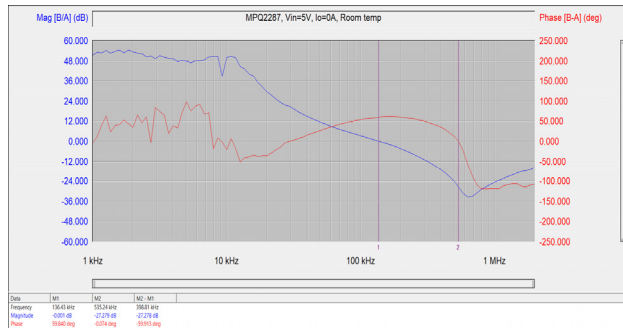

Bode Plot

$I_{OUT} = 14A$, $PM = 61.2^\circ$, $GM = 27.6dB$

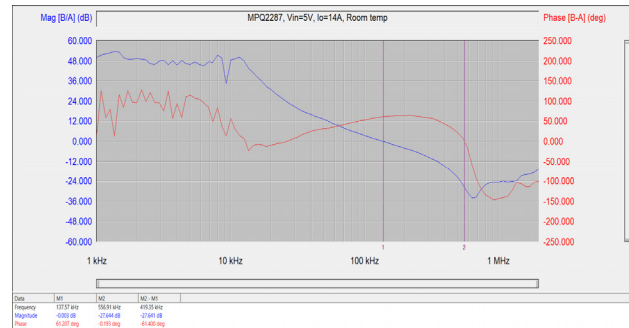

EVB TEST RESULTS (continued)

Performance curves and waveforms are tested on the evaluation board. $V_{IN} = 6V$, $V_{OUT} = 0.75V$, $I_{OUT} = 14A$, $C_{OUT} = 4 \times 47\mu F$, $L = 100nH$, $T_A = 25^\circ C$, unless otherwise noted.

CISPR 25 Class 5 Peak Conducted Emissions

150kHz to 108MHz

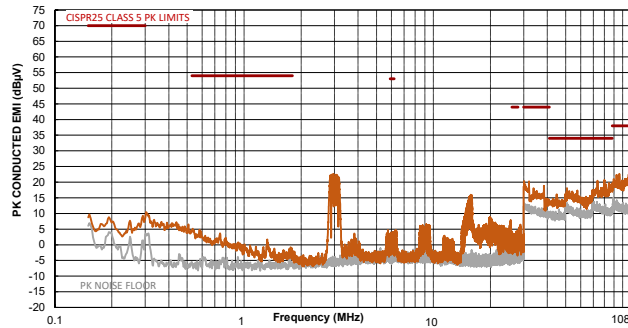

CISPR 25 Class 5 Average Conducted Emissions

150kHz to 108MHz

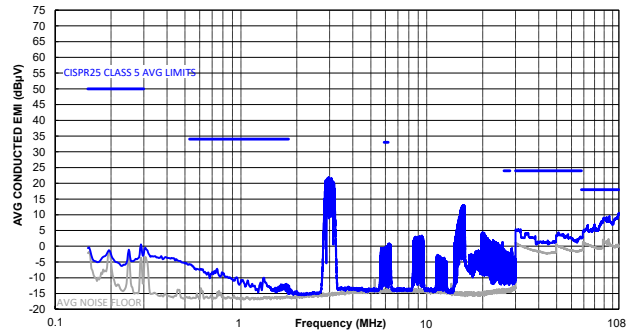

CISPR 25 Class 5 Peak Radiated Emissions

150kHz to 30MHz

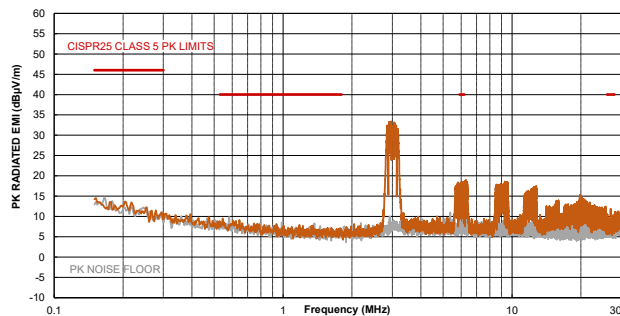

CISPR 25 Class 5 Average Radiated Emissions

150kHz to 30MHz

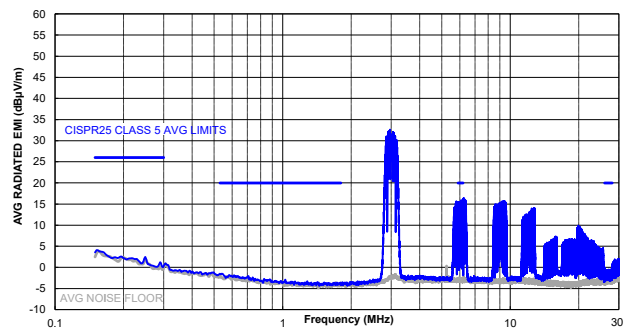

CISPR 25 Class 5 Peak Radiated Emissions

Horizontal, 30MHz to 1GHz

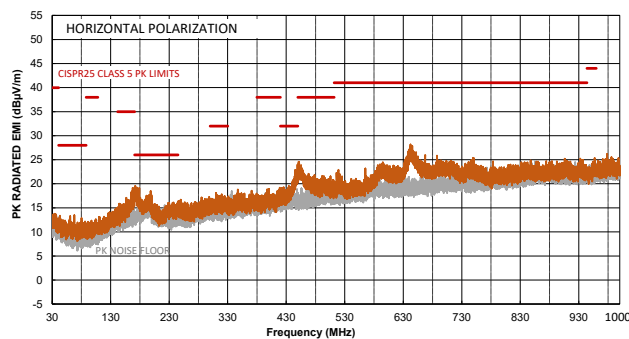

CISPR 25 Class 5 Average Radiated Emissions

Horizontal, 30MHz to 1GHz

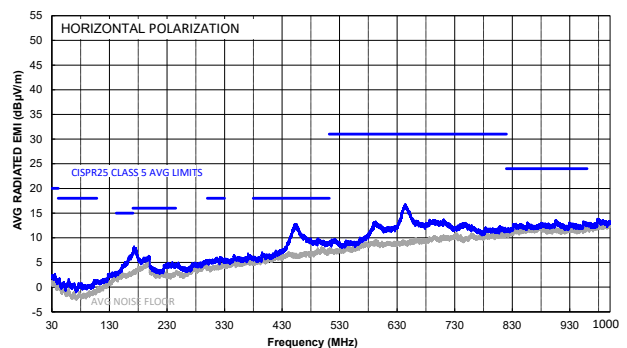

EVB TEST RESULTS *(continued)*

Performance curves and waveforms are tested on the evaluation board. $V_{IN} = 6V$, $V_{OUT} = 0.75V$, $I_{OUT} = 14A$, $C_{OUT} = 4 \times 47\mu F$, $L = 100nH$, $T_A = 25^\circ C$, unless otherwise noted.

CISPR 25 Class 5 Peak Radiated Emissions

Vertical, 30MHz to 1GHz

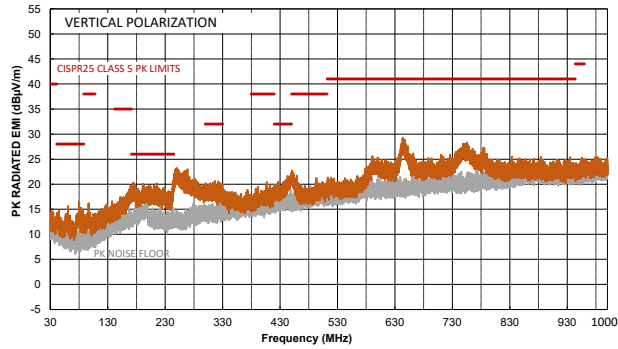

CISPR 25 Class 5 Average Radiated Emissions

Vertical, 30MHz to 1GHz

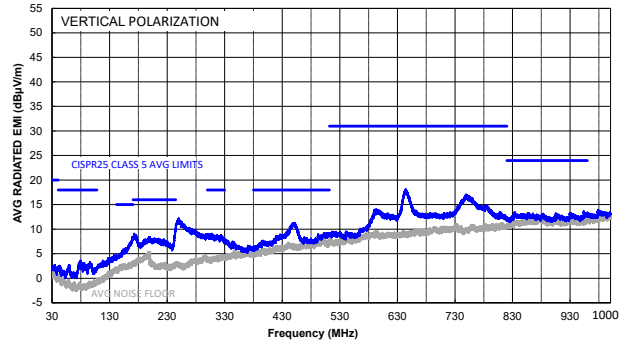

EVB TEST RESULTS (continued)

Performance curves and waveforms are tested on the evaluation board. $V_{IN} = 5V$, $V_{OUT} = 0.75V$, $C_{OUT} = 4 \times 47\mu F$, $L = 100nH$, $T_A = 25^\circ C$, unless otherwise noted.

Steady State

$I_{OUT} = 0A$

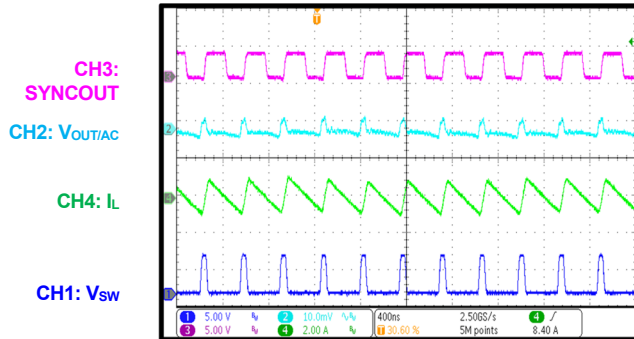

Steady State

$I_{OUT} = 14A$

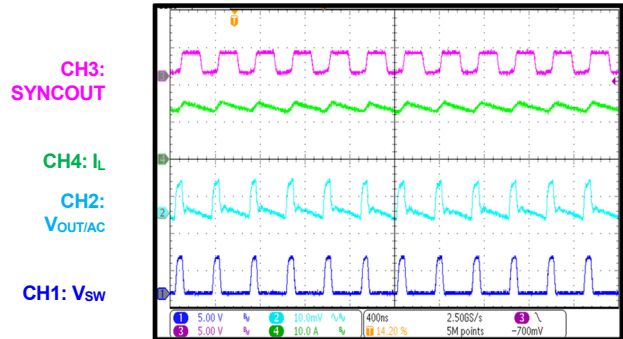

Start-Up through VIN

$I_{OUT} = 0A$, FCCM

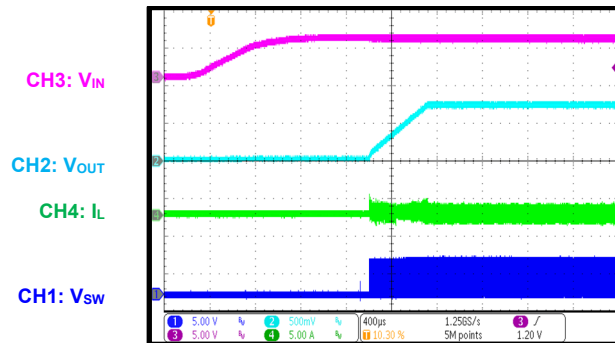

Start-Up through VIN

$I_{OUT} = 14A$

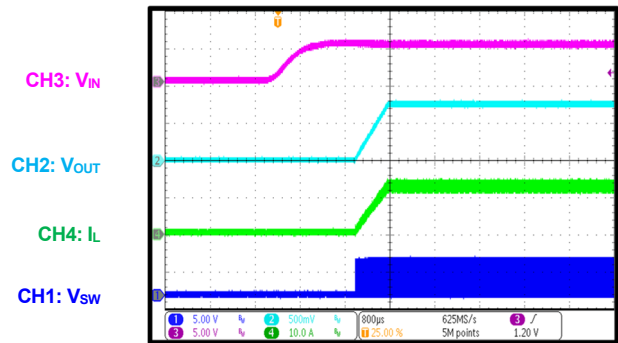

Shutdown through VIN

$I_{OUT} = 0A$, FCCM

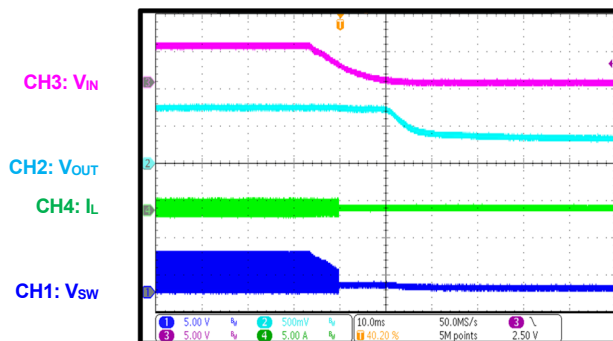

Shutdown through VIN

$I_{OUT} = 14A$

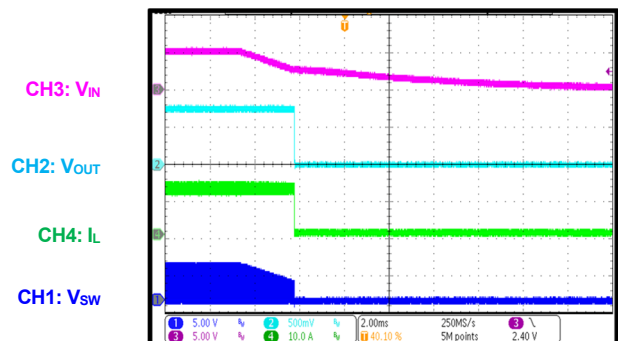

EVB TEST RESULTS (continued)

Performance curves and waveforms are tested on the evaluation board. $V_{IN} = 5V$, $V_{OUT} = 0.75V$, $C_{OUT} = 4 \times 47\mu F$, $L = 100nH$, $T_A = 25^\circ C$, unless otherwise noted.

Start-Up through EN
 $I_{OUT} = 0A$, FCCM

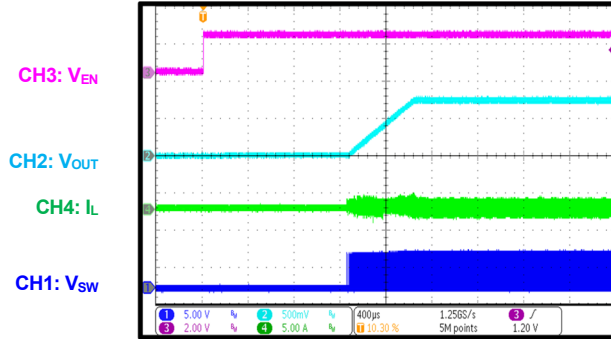

Start-Up through EN
 $I_{OUT} = 14A$

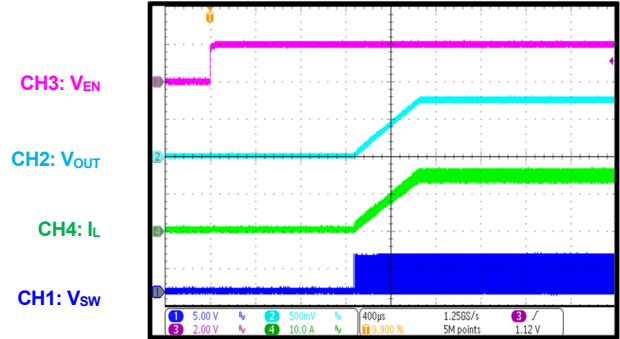

Shutdown through EN
 $I_{OUT} = 0A$, FCCM

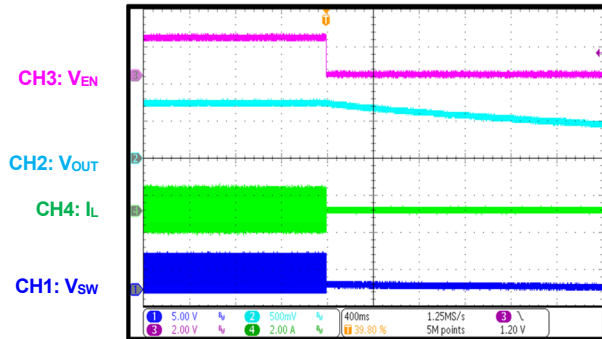

Shutdown through EN
 $I_{OUT} = 14A$

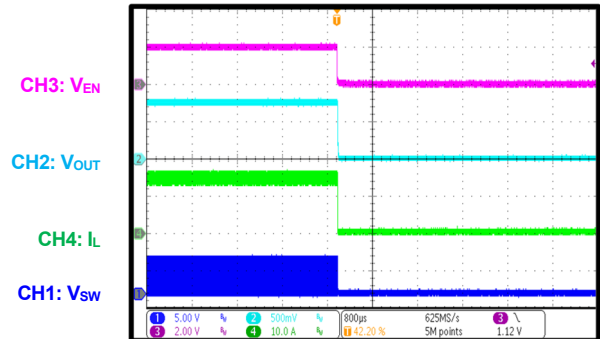

Start-Up via the Digital Interface
 $I_{OUT} = 0A$, FCCM

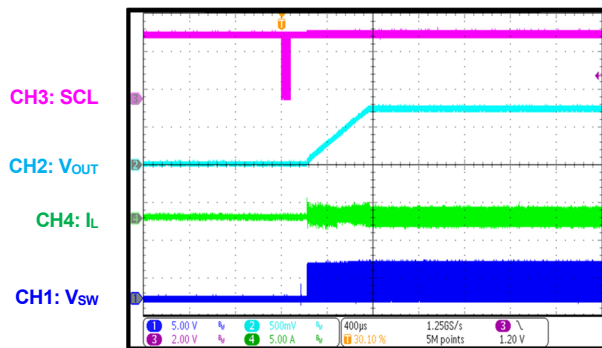

Start-Up via the Digital Interface
 $I_{OUT} = 14A$

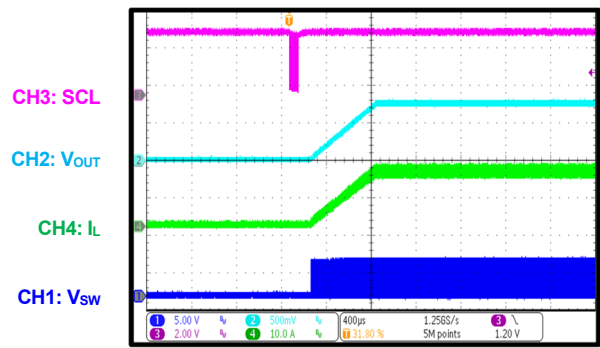

EVB TEST RESULTS (continued)

Performance curves and waveforms are tested on the evaluation board. $V_{IN} = 5V$, $V_{OUT} = 0.75V$, $C_{OUT} = 4 \times 47\mu F$, $L = 100nH$, $T_A = 25^\circ C$, unless otherwise noted.

Shutdown via the Digital Interface

$I_{OUT} = 0A$, FCCM

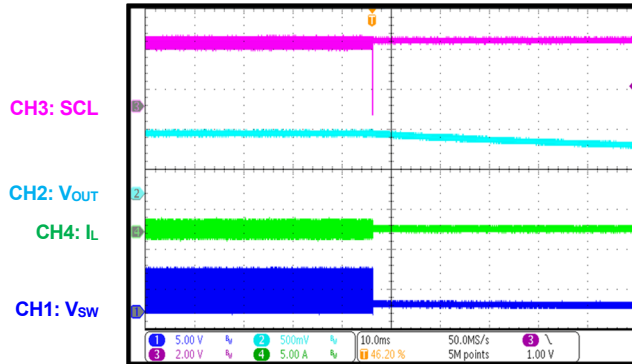

Shutdown via the Digital Interface

$I_{OUT} = 14A$

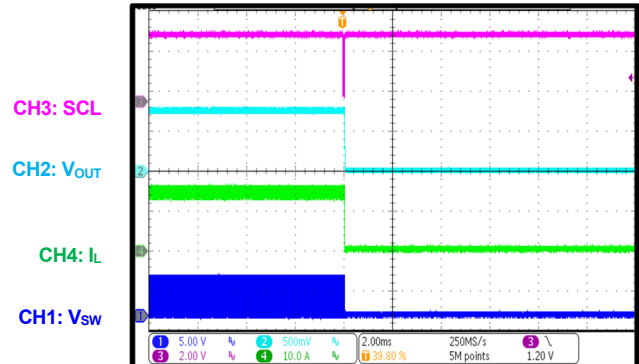

SCP Entry

$I_{OUT} = 0A$, FCCM

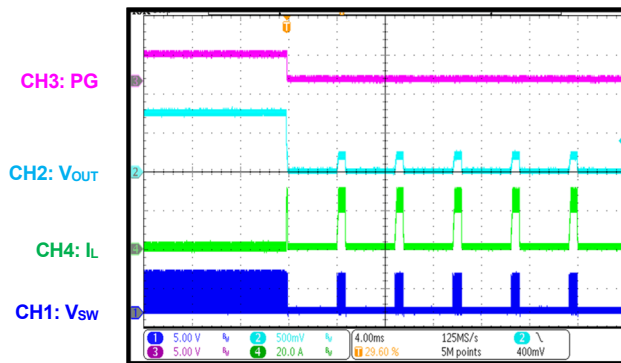

SCP Entry

$I_{OUT} = 14A$

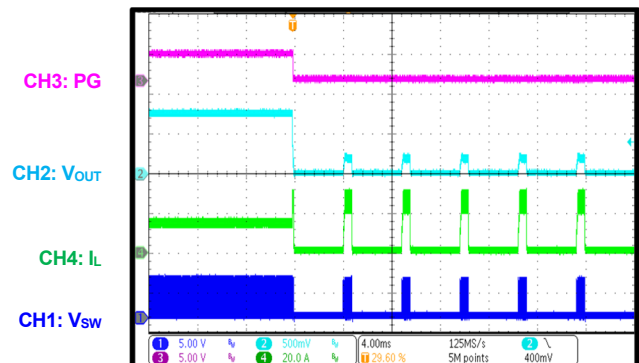

SCP Recovery

$I_{OUT} = 0A$, FCCM

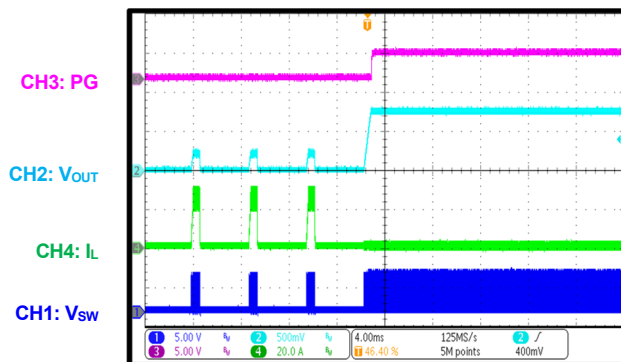

SCP Recovery

$I_{OUT} = 14A$

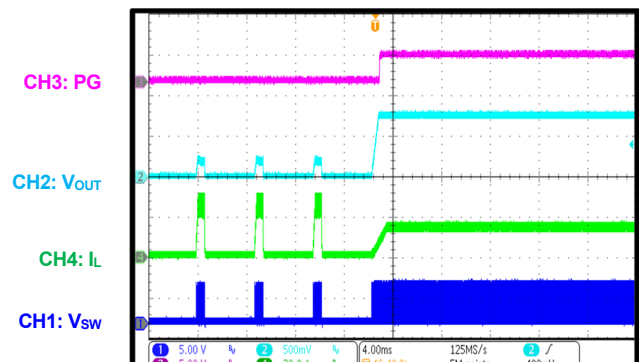

EVB TEST RESULTS (continued)

Performance curves and waveforms are tested on the evaluation board. $V_{IN} = 5V$, $V_{OUT} = 0.75V$, $C_{OUT} = 4 \times 47\mu F$, $L = 100nH$, $T_A = 25^\circ C$, unless otherwise noted.

SCP Steady State

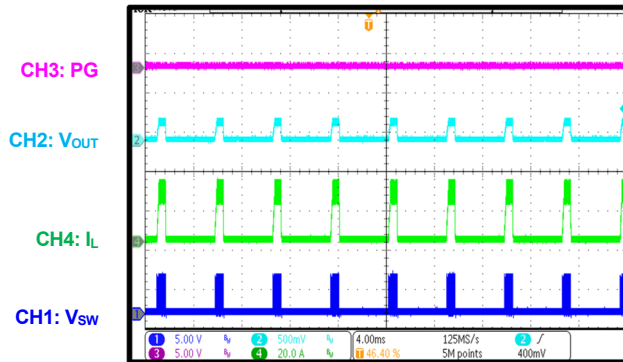

PG Start-Up through VIN

I_{OUT} = 0A, FCCM

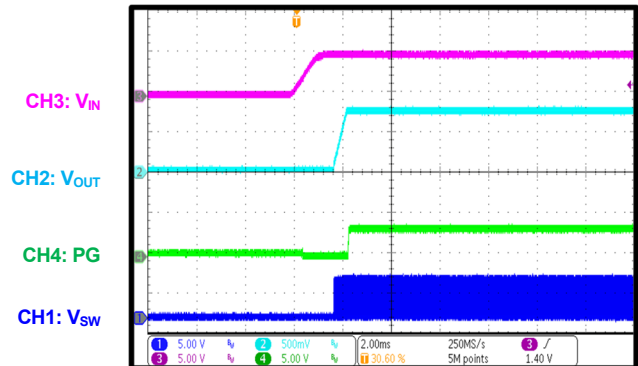

PG Shutdown through VIN

I_{OUT} = 0A, FCCM

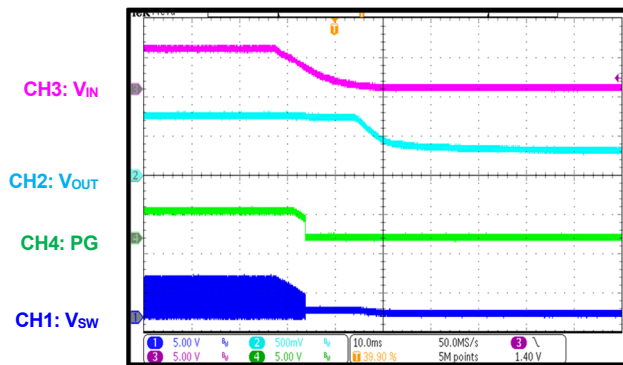

PG Start-Up through VIN

I_{OUT} = 14A

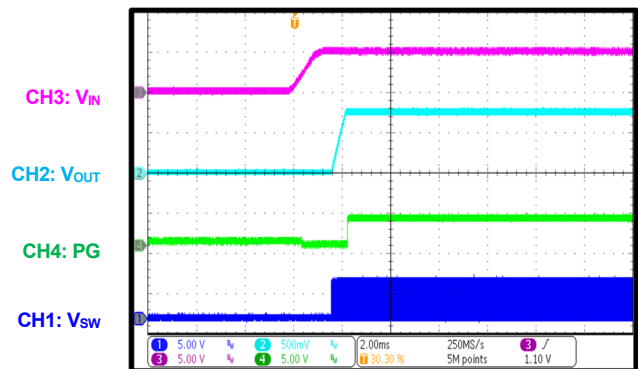

PG Shutdown through VIN

I_{OUT} = 14A

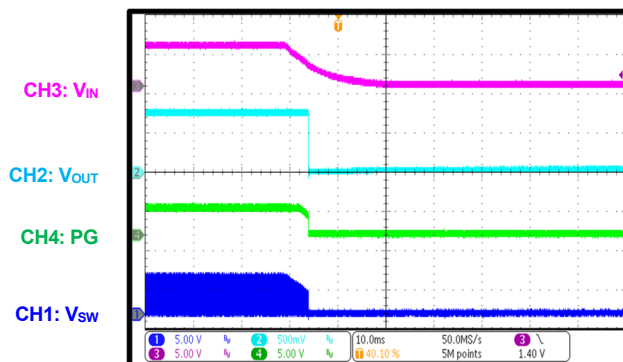

PG Start-Up through EN

I_{OUT} = 0A, FCCM

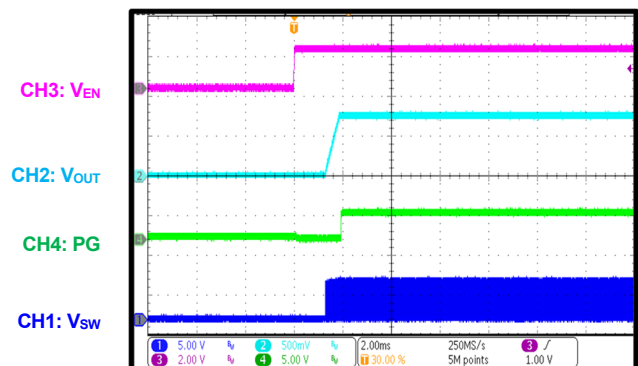

EVb TEST RESULTS (continued)

Performance curves and waveforms are tested on the evaluation board. $V_{IN} = 5V$, $V_{OUT} = 0.75V$, $C_{OUT} = 4 \times 47\mu F$, $L = 100nH$, $T_A = 25^\circ C$, unless otherwise noted.

PG Shutdown through EN

$I_{OUT} = 0A$, FCCM

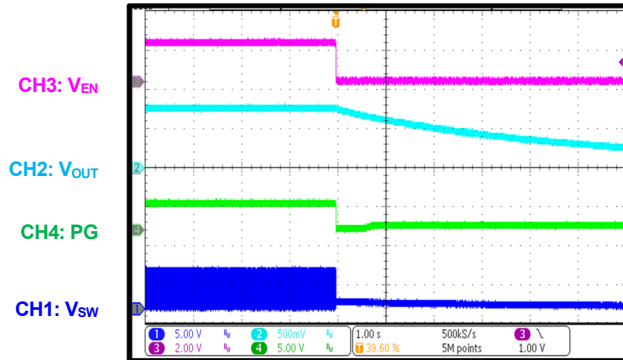

PG Start-Up through EN

$I_{OUT} = 14A$

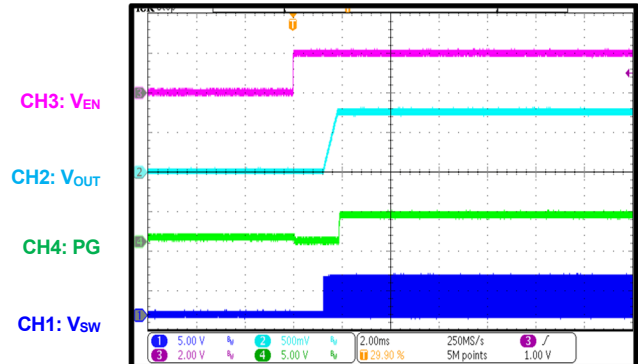

PG Shutdown through EN

$I_{OUT} = 14A$

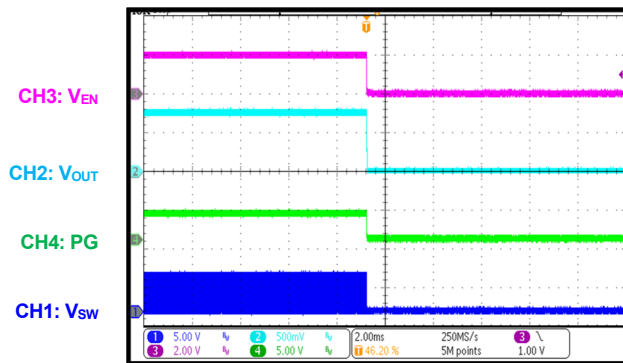

Load Transient Response

$I_{OUT} = 0A$ to $14A$, $1.6A/\mu s$, FCCM

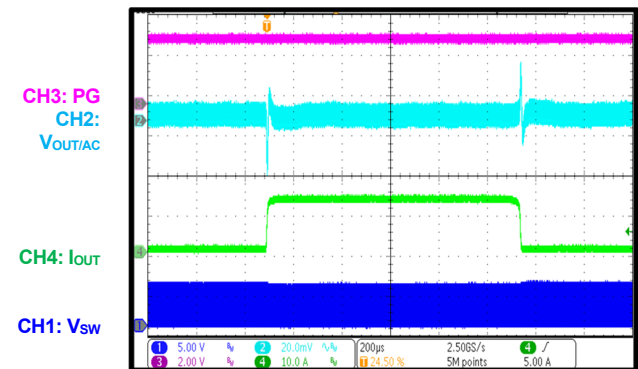

Load Transient Response

$I_{OUT} = 7A$ to $14A$, $1.6A/\mu s$, FCCM

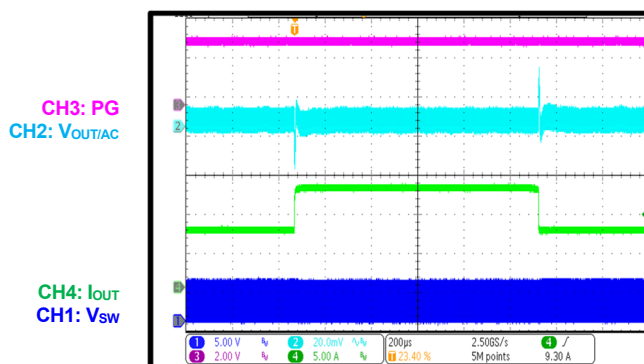

Soft Shutdown via the Digital Interface

$I_{OUT} = 0A$, FCCM

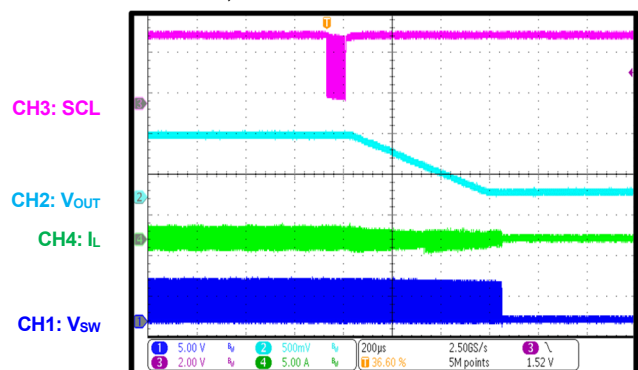

EVB TEST RESULTS *(continued)*

Performance curves and waveforms are tested on the evaluation board. $V_{IN} = 5V$, $V_{OUT} = 0.75V$, $C_{OUT} = 4 \times 47\mu F$, $L = 100nH$, $T_A = 25^\circ C$, unless otherwise noted.

Soft Shutdown via the Digital Interface

$I_{OUT} = 14A$

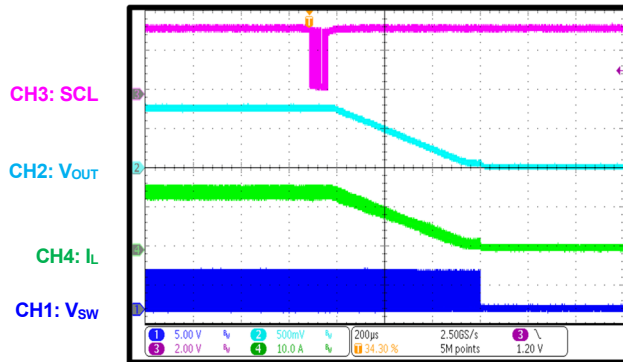

PCB LAYOUT (3)

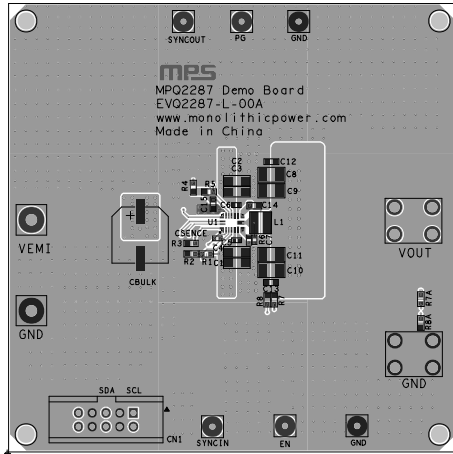

Figure 4: Top Silk and Top Layer

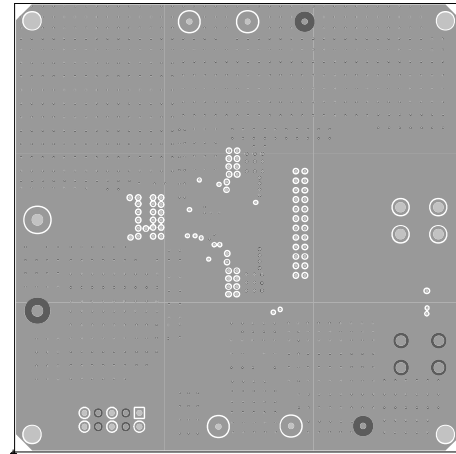

Figure 5: Mid-Layer 1

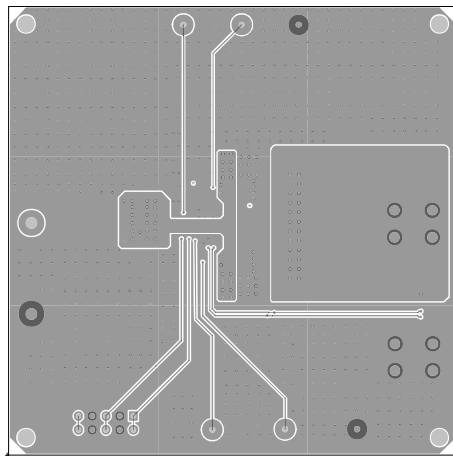

Figure 6: Mid-Layer 2

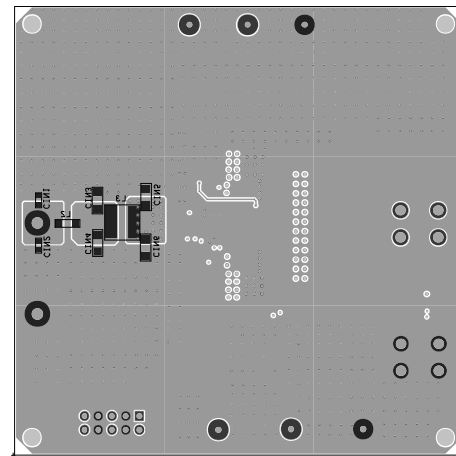

Figure 7: Bottom Layer and Bottom Silk

Note:

3) The copper thickness is 2oz.

REVISION HISTORY

Revision #	Revision Date	Description	Pages Updated
1.0	2/25/2025	Initial Release	-

Notice: The information in this document is subject to change without notice. Please contact MPS for current specifications. Users should warrant and guarantee that third-party Intellectual Property rights are not infringed upon when integrating MPS products into any application. MPS will not assume any legal responsibility for any said applications.