

DESCRIPTION

The MP3205 is a step-up converter designed for driving up to 5 series white LEDs from a single cell Lithium Ion battery. The MP3205 uses current mode, fixed frequency architecture to regulate the LED current, which is measured through an external current sense resistor. Its low 104mV feedback voltage reduces power loss and improves efficiency.

The MP3205 includes under-voltage lockout, current limiting and thermal overload protection preventing damage in the event of an output overload. The MP3205 is available in a small 5-pin TSOT23 package.

EVALUATION BOARD REFERENCE

Board Number	Dimensions
EV3205DJ-00A	1.9"X x 1.8"Y x 0.4"Z

FEATURES

- On Board Power MOSFET
- Drives up to 5 Series White LEDs
- Up to 87% Efficiency
- Over 1MHz Fixed Switching Frequency
- Low 104mV Feedback Voltage
- Soft-Start/PWM Dimming
- UVLO, Thermal Shutdown
- Internal Current Limit
- Available in a TSOT23-5 Package

APPLICATIONS

- Cell Phones
- Handheld Computers and PDAs
- Digital Still Cameras
- Small LCD Displays Application

"MPS" and "The Future of Analog IC Technology" are Trademarks of Monolithic Power Systems, Inc.

TYPICAL APPLICATION

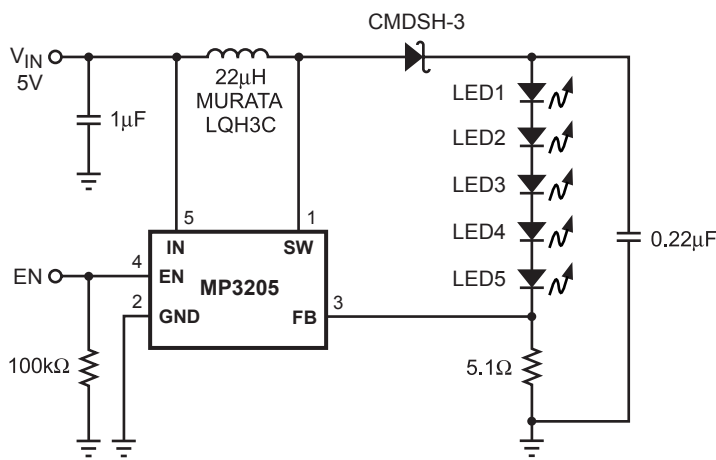

MP3205-TAC-S01

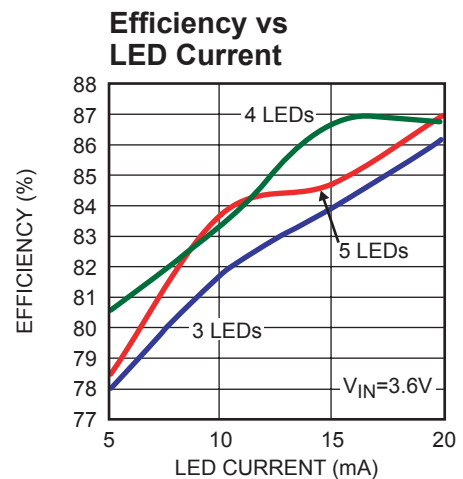

MP3205-EC01

PACKAGE REFERENCE

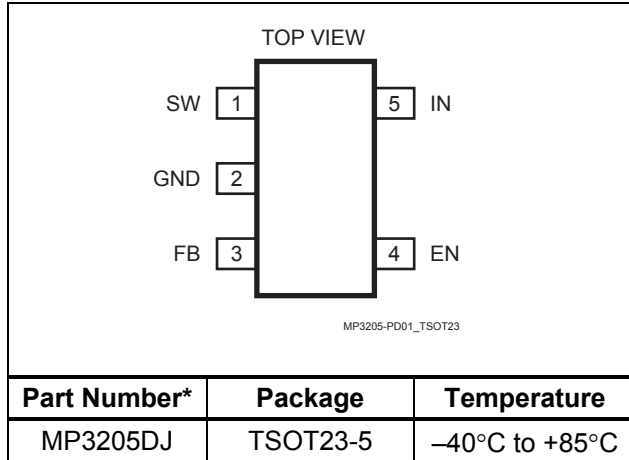

* For Tape & Reel, add suffix -Z (eg. MP3205DJ-Z)
 For Lead Free, add suffix -LF (eg. MP3205DJ -LF-Z)

ABSOLUTE MAXIMUM RATINGS ⁽¹⁾

SW.....-0.5V to +28V
 All Other Pins.....-0.3V to +6.5V
 Storage Temperature-55°C to +150°C

Recommended Operating Conditions ⁽²⁾

IN Supply Voltage.....2.5V to 6V
 Output Voltage..... V_{IN} to 21V
 Operating Temperature-40°C to +85°C

Thermal Resistance ⁽³⁾

	θ_{JA}	θ_{JC}
TSOT23-5.....	220	110

°C/W

Notes:

- 1) Exceeding these ratings may damage the device.
- 2) The device is not guaranteed to function outside of its operating conditions.
- 3) Measured on approximately 1" square of 1 oz copper.

ELECTRICAL CHARACTERISTICS

$V_{IN} = V_{EN} = 5V$, $T_A = +25^\circ C$, unless otherwise noted.

Parameter	Symbol	Condition	Min	Typ	Max	Units
Using Parameter Set Heading						
Operating Input Voltage	V_{IN}		2.5		6	V
Supply Current (Shutdown)		$V_{EN} = 0V$		0.1	1	μA
Supply Current (Quiescent)		$V_{FB} = 0.15V$		690	750	μA
Switching Frequency	f_{SW}		1.0	1.3	1.5	MHz
Maximum Duty Cycle		$V_{FB} = 0V$	85	92		%
Undervoltage Lockout						
IN Under Voltage Lockout	UVLO	V_{IN} Rising		2.25	2.45	V
Under Voltage Lockout Hysteresis				92		mV
Enable						
EN Threshold		V_{EN} Rising	1.0	1.35	1.6	V
EN Threshold		V_{EN} Rising, $V_{IN} = 2.5V$	0.8			V
EN Hysteresis				90		mV
EN Input Bias Current		$V_{EN} = 0V, 5V$			1	μA
Feedback						
FB Voltage			94	104	114	mV
FB Input Bias Current		$V_{FB} = 0.1V$	-600	-300		nA
Output Switch						
SW On-Resistance ⁽⁴⁾	R_{ON}			0.5		Ω
SW Current Limit		Duty Cycle = 60%		350		mA
Thermal Shutdown ⁽⁴⁾				160		°C

Note:

4) Guaranteed by design.

PIN FUNCTIONS

Pin #	Name	Description
1	SW	Power Switch Output. SW is the drain of the internal MOSFET switch. Connect the power inductor and output rectifier to SW. SW can swing between GND and 25V.
2	GND	Ground.
3	FB	Feedback Input. The MP3205 regulates the voltage across the current sense resistor between FB and GND. Connect a current sense resistor from the bottom of the LED string to GND. Connect the bottom of the LED string to FB. The regulation voltage is 104mV.
4	EN	Regulator On/Off Control Input. A high input at EN turns on the converter, and a low input turns it off. When not used, connect EN to the input source for automatic startup. The EN pin cannot be left floating.
5	IN	Input Supply Pin. Must be locally bypassed.

OPERATION

The MP3205 uses a constant frequency, peak current mode boost regulator architecture to regulate the series string of white LEDs. The operation of the MP3205 can be understood by referring to the block diagram of Figure 1. At the start of each oscillator cycle the FET is turned on through the control circuitry. To prevent sub-harmonic oscillations at duty cycles greater than 50 percent, a stabilizing ramp is added to the output of the current sense amplifier and the result is fed into the positive input of the PWM comparator.

When this voltage equals the output voltage of the error amplifier the power FET is turned off. The voltage at the output of the error amplifier is an amplified version of the difference between the 104mV reference voltage and the feedback voltage. In this way the peak current level keeps the output in regulation. If the feedback voltage starts to drop, the output of the error amplifier increases. This results in more current to flow through the power FET, thus increasing the power delivered to the output.

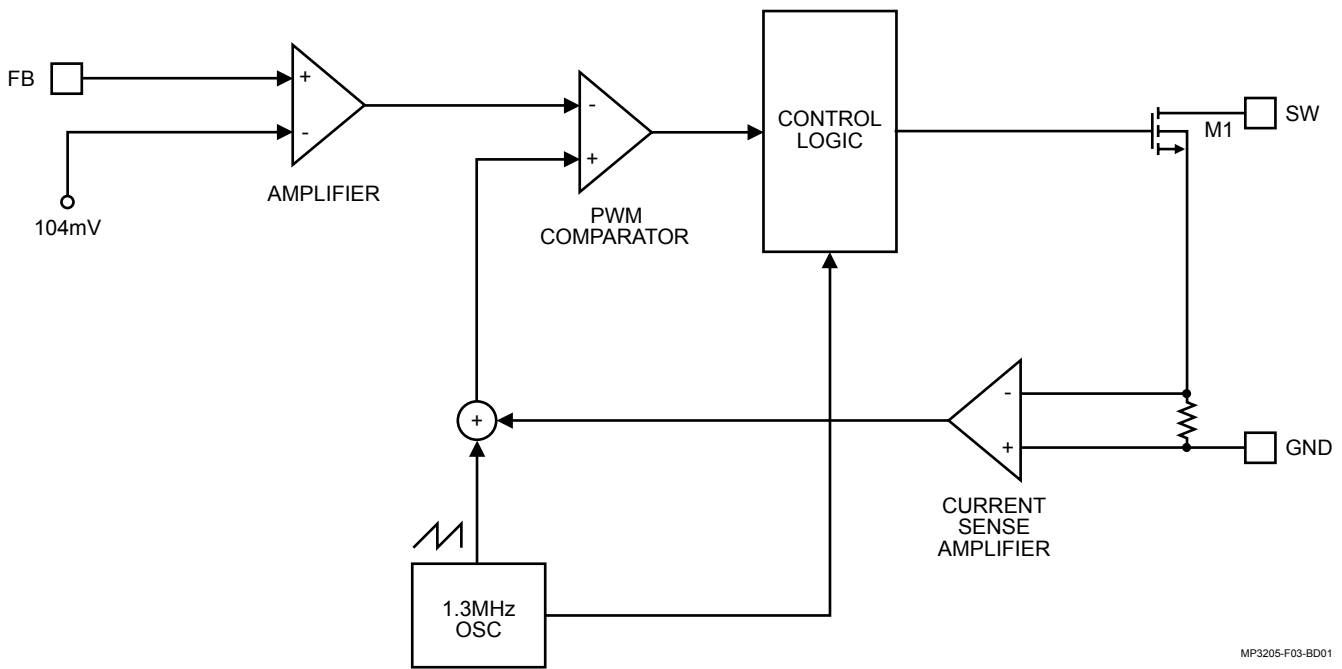

Figure 1—Functional Block Diagram

MP3205-F03-BD01

APPLICATION INFORMATION

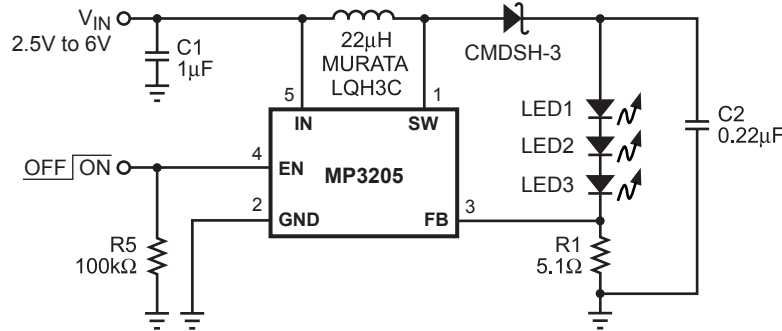

Figure 2—Driving 3 White LEDs

COMPONENT SELECTION

A typical application circuit can be seen in Figure 2. The 3 white LEDs can be driven from a voltage supply range of 2.5V to 6V at an output current of 20mA. A 0.22µF output capacitor is sufficient for most applications but an output capacitor up to 1µF may be used. A 22µH inductor with low DCR (Inductor resistance) is recommended to improve efficiency. A 1µF ceramic capacitor is recommended for the input capacitance in the real system. Schottky diodes have fast recovery and a low forward voltage and are recommended.

Schottky diodes rated with 100mA to 200mA are sufficient for the MP3205. The switching characteristics during normal operation can be seen in Figure 3. The MP3205 has internal soft-start to limit the amount of current through V_{IN} at startup and to also limit the amount of overshoot on the output. The current limit is increased by a fourth every 40µs giving a total soft-start time of 120µs.

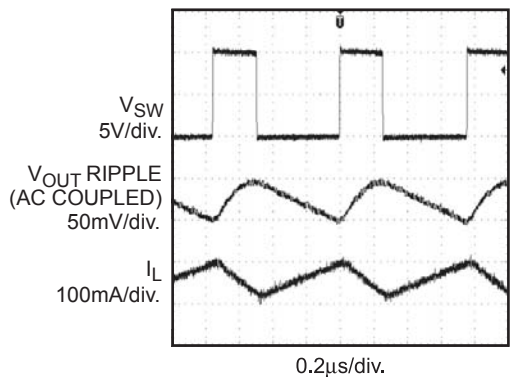

Figure 3—Steady-State Operation
 $V_{IN}=3.6V$, 3 LEDs, 20mA

Figure 4 shows the startup behavior of the MP3205. The ramped voltage that is added to the current sense amplifier reduces the current output as the duty cycle increases. As more LEDs are added, the output voltage rises but the current that can be delivered to the load is reduced as well.

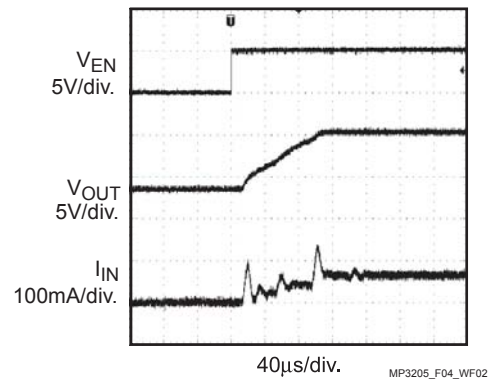

Figure 4—Startup Waveforms
 $V_{IN}=3.6V$, 3 LEDs, 20mA

Figure 5 shows the dependence on current limit versus duty cycle.

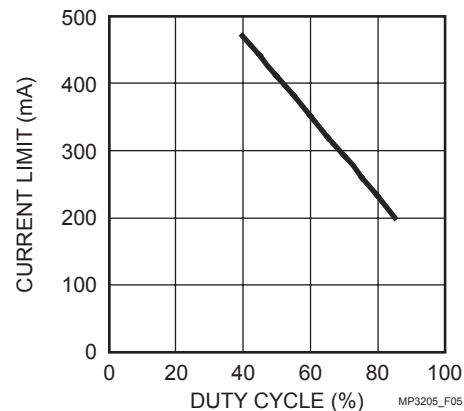

Figure 5—Current Limit vs. Duty Cycle

Setting the LED Current

The LED current is controlled by the feedback resistor, R1, in Figure 2. The current through the LEDs is given by the equation $104\text{mV}/R1$. Table 1 shows the selection of resistors for a given LED current.

Table 1— I_{LED} vs. R1

I_{LED} (mA)	R1 (Ω)
1	104
5	20.8
10	10.4
15	6.93
20	5.2

Analog and Digital Dimming

There are three different ways to control dimming for the MP3205 during normal operation. The first way uses a DC voltage to control the feedback voltage. This can be seen in Figure 6. As the DC voltage increases, current starts flowing down R1, R2 and R3. The loop will continue to regulate the feedback voltage to 104mV. Thus the current has to decrease through the LEDs by the same amount of current as is being injected from the DC voltage source. With a V_{DC} from 0V to 2V, the resistor values shown for R2 and R3 can control the LED current from 0mA to 20mA.

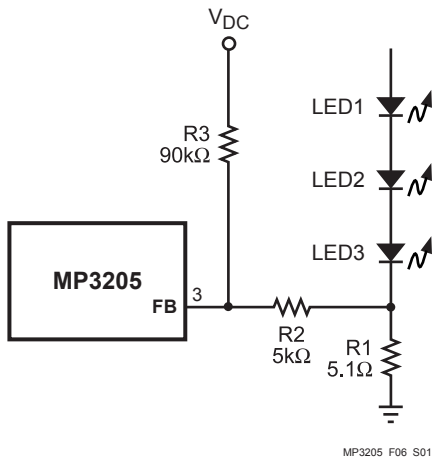

Figure 6—Dimming Control Using a DC Voltage

Other applications need to use a logic signal to do the dimming. This can be seen in Figure 7. The PWM signal is applied to the EN pin of the MP3205. The LEDs will switch between full load to completely shut off. The average current through the LEDs will increase proportionally to the duty cycle of the PWM signal. The PWM

signal used in Figure 7 should be 1KHz or below due to the soft start function.

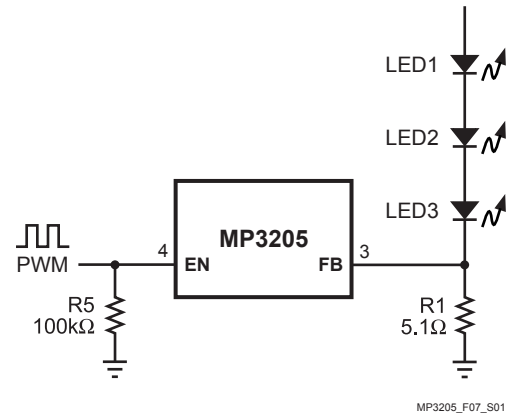

Figure 7—PWM Dimming Control Using a Logic Signal

If the PWM signal is above 1KHz, dimming can be achieved by using the circuit shown in Figure 8.

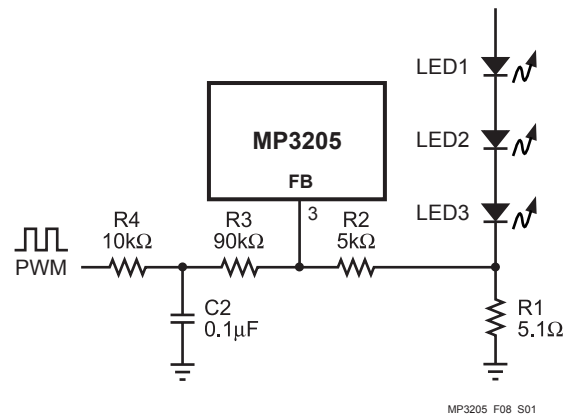
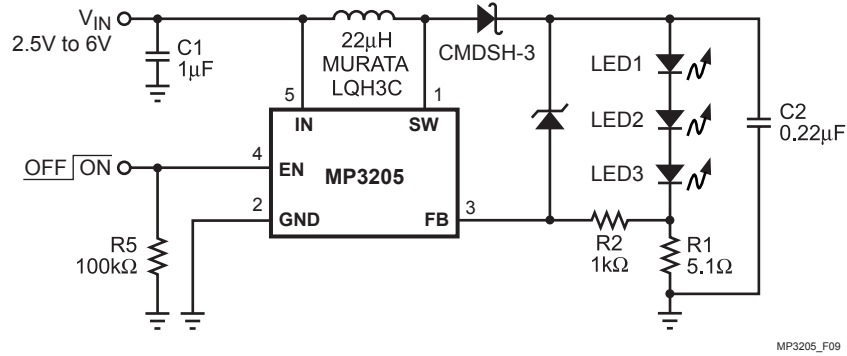

Figure 8—Dimming Control Using a Filtered PWM Signal

Layout Considerations

Careful attention must be paid to the PCB board layout and component placement. Proper layout of the high frequency switching path is critical to prevent noise and electromagnetic interference problems. Due to the high frequency switching the length and area of all the traces connected to the switch node should be minimized. Refer to the evaluation board EV3205DJ-00A for a sample layout of the MP3205.

Figure 9—LED Driver with Overload Protection

PACKAGE INFORMATION

TSOT23-5

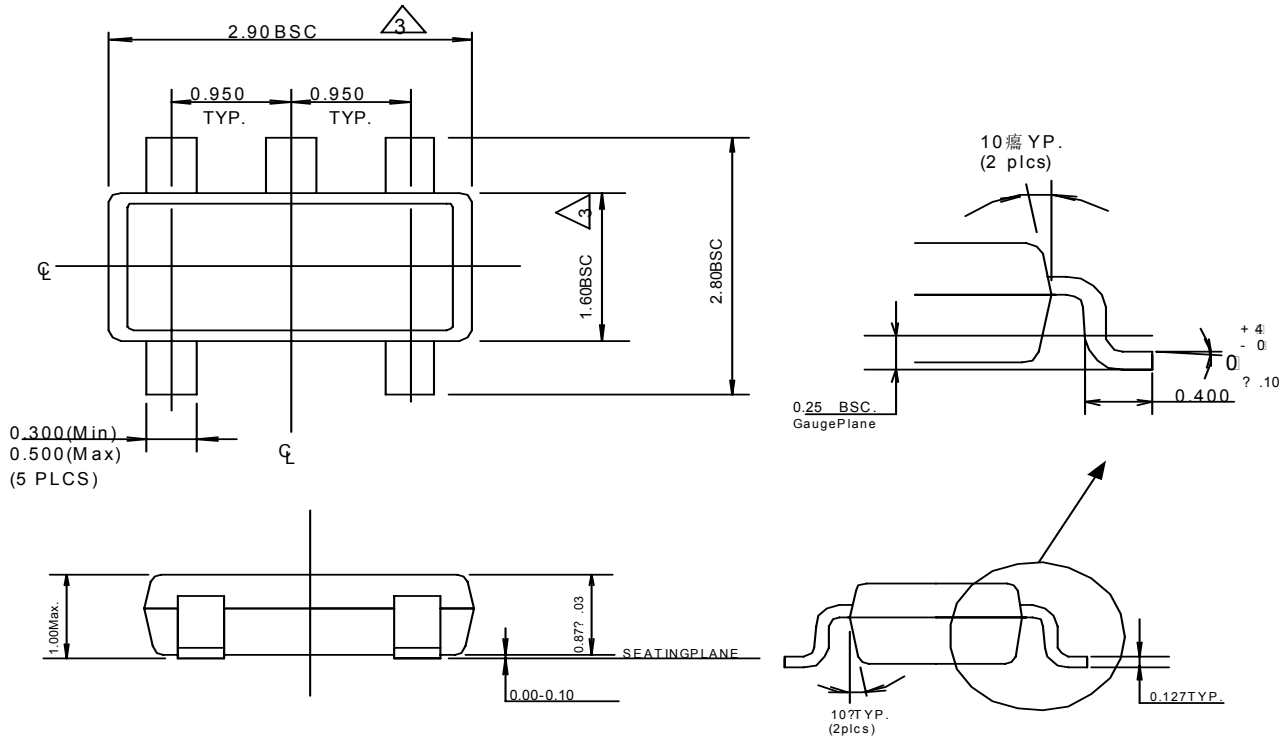

Dimensions are in millimeters

- Note:
1. Dimensions and tolerances are as per ANSI Y14.5M, 1994.
 2. Die is facing up for mold. Die is facing down for trim/form, ie. Reverse trim/form
 3. Dimensions are exclusive of mold flash and gate burr.
 4. The footlength measuring is based on the gauge plane method.
 5. All specification comply to Jedec Spec MO193 Issue C.

NOTICE: The information in this document is subject to change without notice. Please contact MPS for current specifications. Users should warrant and guarantee that third party Intellectual Property rights are not infringed upon when integrating MPS products into any application. MPS will not assume any legal responsibility for any said applications.