



The Future of Analog IC Technology®

MP2605

28V, 1A Li-Ion/Li-Polymer Battery Charger with Trickle Charge and Timer

DESCRIPTION

The MP2605 is a linear, high-performance single cell Li-Ion/Li-Polymer battery charger. By integrating high voltage input protection into the charger IC, the MP2605 can tolerate an input surge up to +28V.

The device features constant current (CC) and constant voltage (CV) charging modes with programmable charge currents (200mA to 1A), current blocking, and trickle charge. The device also provides fault and charge status indications to the system.

For guaranteed safe operation, the MP2605 reduces charge current when the device reaches high temperature (due to limited PCB space). Other safety features include battery temperature monitoring and programmable timer to complete the charging cycle.

The MP2605 is available in 10-pin 3mm x 3mm QFN packages.

FEATURES

- Proprietary V_{IN} Surge Protection up to 28V
- Programmable Charge Current : 200mA to 1.0A
- Trickle Charge
- 40 μ A Shutdown Current
- 7V Input OVP
- Auto Recharge
- Charge-Timer
- Fault and Charge Status Indicators

APPLICATIONS

- Cell Phones
- Digital Cameras
- Smart Phones
- PDAs
- MP3 Players

"MPS" and "The Future of Analog IC Technology" are Registered Trademarks of Monolithic Power Systems, Inc.

TYPICAL APPLICATION

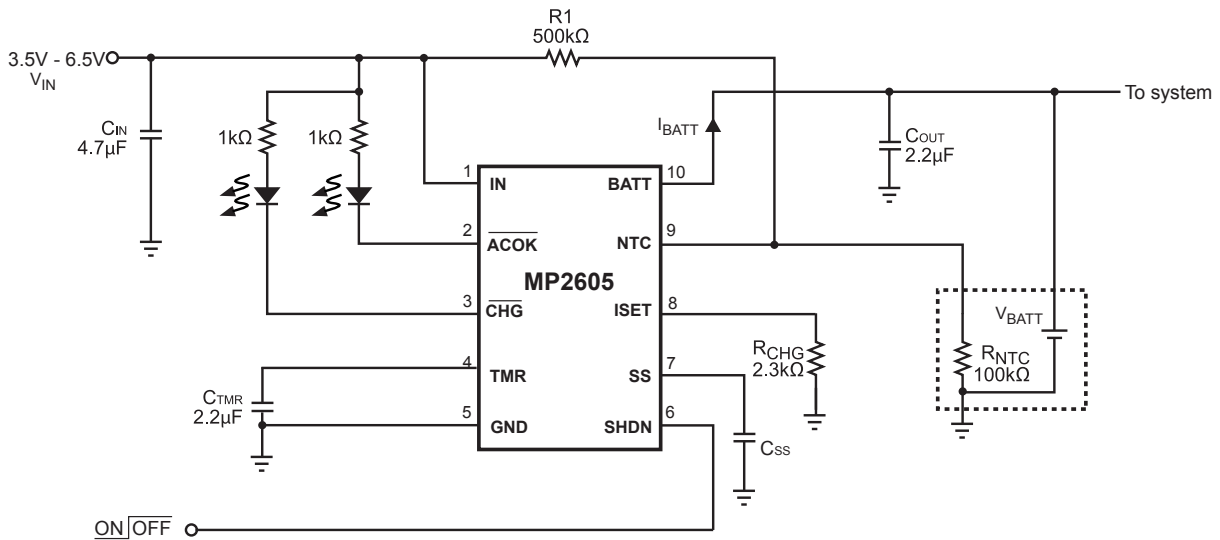

ORDERING INFORMATION

Part Number*	Package	Top Marking	Free Air Temperature (T _A)
MP2605DQ	QFN10 (3mm x 3mm)	U4YW	-40°C to +85°C

* For Tape & Reel, add suffix -Z (e.g. MP2605DQ-Z).
 For RoHS Compliant packaging, add suffix -LF (e.g. MP2605DQ-LF-Z)

PACKAGE REFERENCE

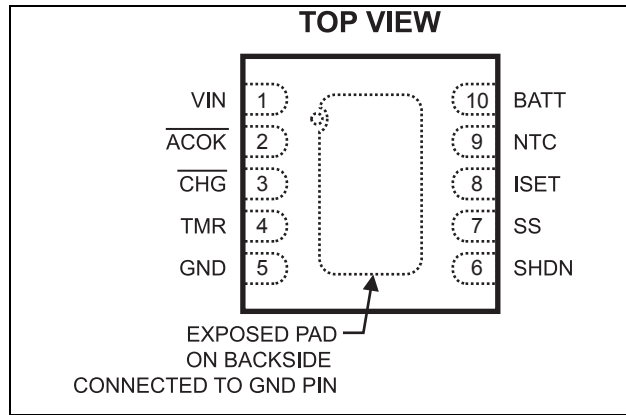

ABSOLUTE MAXIMUM RATINGS ⁽¹⁾

IN to GND	-0.3V to +28V
ACOK and CHG Maximum Sink Current.....	20mA
All Other Pins to GND.....	-0.3V to +6.5V
Continuous Power Dissipation (T _A = +25°C) ⁽²⁾2.5W
Junction Temperature.....	140°C
Lead Temperature	260°C
Storage Temperature.....	-65°C to +150°C

Recommended Operating Conditions ⁽³⁾

Nominal Supply Voltage V _{IN}	3.5V to 6.5V
Operating Junct. Temp (T _J).....	-40°C to +125°C

Thermal Resistance ⁽⁴⁾	θ_{JA}	θ_{JC}
3x3 QFN10.....	50	12 ... °C/W

Notes:

- 1) Exceeding these ratings may damage the device.
- 2) The maximum allowable power dissipation is a function of the maximum junction temperature T_J (MAX), the junction-to-ambient thermal resistance θ_{JA}, and the ambient temperature T_A. The maximum allowable continuous power dissipation at any ambient temperature is calculated by P_D (MAX) = (T_J (MAX)-T_A)/θ_{JA}. Exceeding the maximum allowable power dissipation will cause excessive die temperature, and the regulator will go into thermal shutdown. Internal thermal shutdown circuitry protects the device from permanent damage.
- 3) The device is not guaranteed to function outside of its operating conditions.
- 4) Measured on JESD51-7, 4-layer PCB

ELECTRICAL CHARACTERISTICS

$V_{IN} = 5V$, $V_{SHDN} = 0V$, $T_A = +25^{\circ}C$, unless otherwise noted.

Parameter	Symbol	Condition	Min	Typ	Max	Units
Supply Current	I_{SUPPLY}	SHDN = High		40		μA
		SHDN = Low, $I_{CHG} = 0A$, $V_{BATT} = 4.1V$		200		μA
Battery Voltage Regulation	V_{BATT}	$T = -5^{\circ}C$ to $+75^{\circ}C$, $I_{BATT} = 0$	4.16	4.20	4.24	V
Constant Current Regulation	I_{CHG}	$V_{IN} = 5V$, $V_{BATT} = 3.8V$ $R_{CHG} = 3.3k\Omega$	448	515	582	mA
Constant Current Variation ⁽⁵⁾		$V_{IN} = 5V$, $V_{BATT} = 3.8V$, $T_J = 0^{\circ}C$ to $+120^{\circ}C$, $R_{CHG} = 1.6k\Omega$ to $8.0k\Omega$	87	100	113	% I_{CHG}
End of Charge Threshold ⁽⁵⁾	I_{BF}			20		% I_{CHG}
Trickle Current ⁽⁵⁾		$V_{IN} = 5V$, $V_{BATT} = 2.3V$	5	10	15	% I_{CHG}
Trickle Threshold Voltage			2.45	2.6	2.75	V
Trickle Voltage Hysteresis				100		mV
Input \overline{ACOK} Up Range			6.7	7	7.3	V
Input \overline{ACOK} Low Range			1.5	2	2.5	V
\overline{ACOK} and \overline{CHG} Over-voltage Clamp	V_Z			8.2		V
Input Over Voltage Protection	OVP	V_{IN} Rising	6.7	7	7.3	V
OVP Hysteresis				400		mV
SHDN Trip Threshold High			2.6			V
SHDN Trip Threshold Low					0.4	V
SHDN Pull up Current	I_{SHDN}	$V_{SHDN} = 3V$		6		μA
\overline{CHG} , \overline{ACOK} Sink Current		Pin Voltage = 0.4V	8			mA
Battery Reverse Current to BATT Pin		SHDN = Low and Input = Floating or 0V			1	μA
Dropout voltage	$V_{IN} - V_{BATT}$	$V_{BATT} = 3.8V$, $R_{CHG} = 6k\Omega$. Current drop 10%		0.25		V
Die temperature Limit			105	120	135	$^{\circ}C$
Recharge Voltage Threshold	$V_{RECHARGE}$		3.9	4.0	4.1	V
Recharge Voltage hysteresis				100		mV
R_{NTC} at $0^{\circ}C$		Note: R_{NTC} is 100k at $25^{\circ}C$ $R_{NTC} = TH11-4H104F$		376.6		k Ω
R_{NTC} at $50^{\circ}C$		Note: R_{NTC} is 100k at $25^{\circ}C$ $R_{NTC} = TH11-4H104F$		32.3		k Ω

ELECTRICAL CHARACTERISTICS *(continued)*

$V_{IN} = 5V$, $V_{SHDN} = 0V$, $T_A = +25^{\circ}C$, unless otherwise noted.

Parameter	Symbol	Condition	Min	Typ	Max	Units
Oscillation Freq		$C_{TMR} = 2.2\mu F$		5		Hz
TMR Pin Source Current	I_{TMR1}	$V_{TMR}=0.1V$		20		μA
TMR Pin Sink Current	I_{TMR2}	$V_{TMR}=1.5V$		20		μA
Soft Start Time		From Trickle to 90% Full Current, $C_{SS}=0.1\mu F$	70	80	90	mS

Notes:

5) I_{CHG} is the target preprogrammed charge current (Die temperature below $110^{\circ}C$).

PIN FUNCTIONS

Pin #	Name	Description
1	VIN	Input Supply Pin. VIN receives the AC adapter or USB supply voltage.
2	ACOK	Open-Drain Fault Status Indicator. This pin is high under any fault conditions.
3	CHG	Open-Drain Charge Indicator. This pin is low during charging, is high after battery full or termination, and is toggling when the battery is in fault condition.
4	TMR	Oscillator Period Timer. Connect a timing capacitor between this pin and GND to set the oscillator period.
5	GND, Exposed Pad	The exposed pad and GND pin must be connected to the same ground plane.
6	SHDN	Charger IC Enable. An input “Low” signal at this pin or pin floating will enable the IC.
7	SS	Soft-Start. Connect a capacitor to ground to set the soft-start time. The rising time constant is $400 \times 10^3 \times C_{SS}$, where C_{SS} is in μF .
8	ISET	Constant Charge Current Program Pin. Connect this pin to an external resistor to program the charging current in CC Mode.
9	NTC	Negative Temperature Coefficient (NTC) Thermistor Pin. Connect a 500k Ω resistor from this pin to the VIN pin and a 100k Ω NTC resistor (within the battery pack) from this pin to ground. If NTC function is not used, replace NTC resistor with a regular 100k Ω resistor from this pin to ground. Do not leave this pin floating.
10	BATT	Charger Output.

BLOCK DIAGRAM

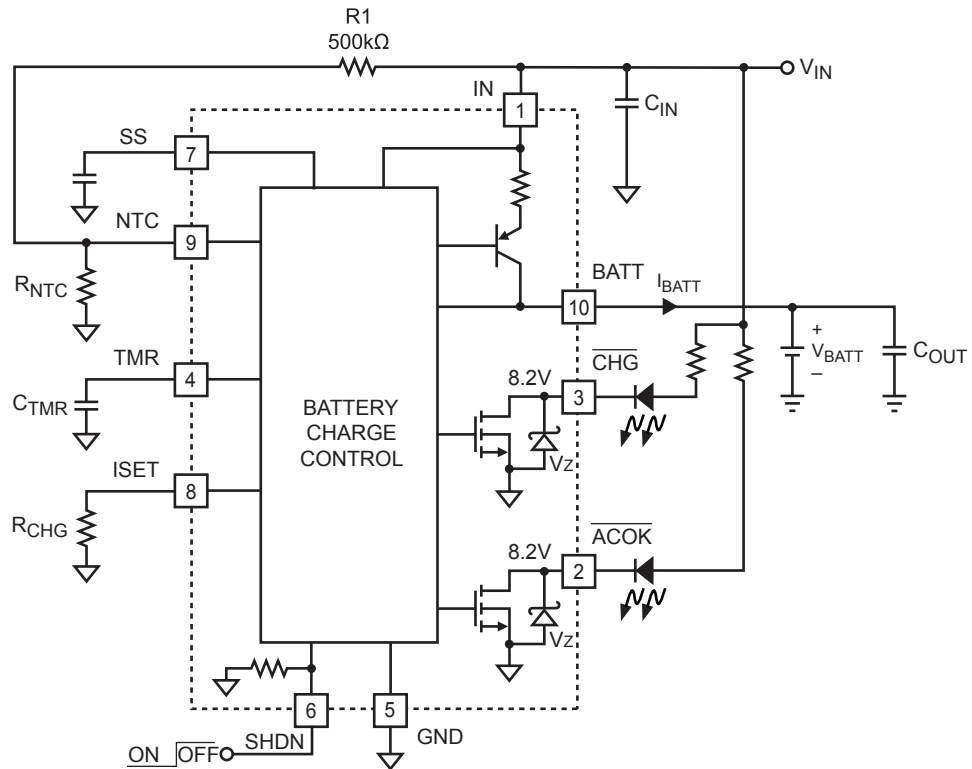
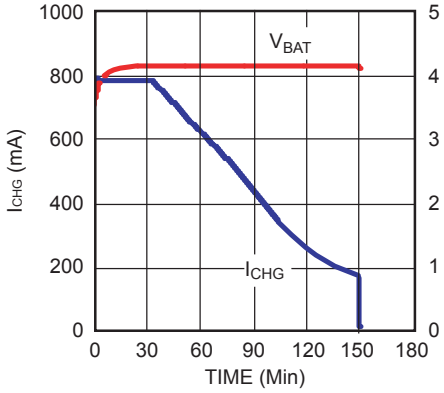

Figure 1—Functional Block Diagram

TYPICAL PERFORMANCE CURVES

$C_{IN} = 4.7\mu F$, $C_{OUT} = 2.2\mu F$, $V_{IN} = 5V$, $T_A = +25^\circ C$, unless otherwise noted.

Battery Charge Curve



Charge Current vs Battery Voltage

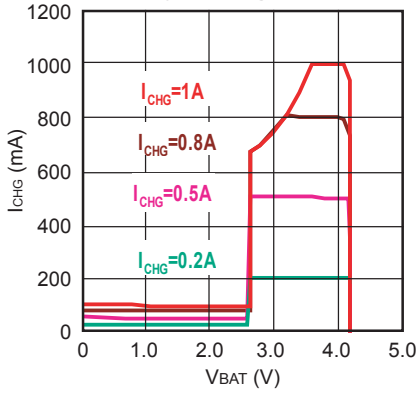

Charge Current vs Battery Voltage

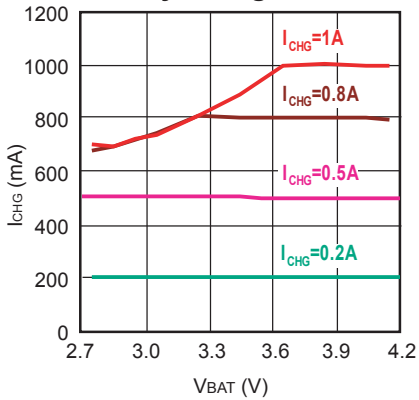

I_{CHG} Current vs Input Voltage

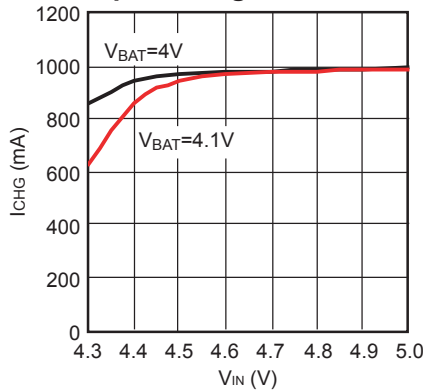

1/R_{SET} vs. I_{SET}

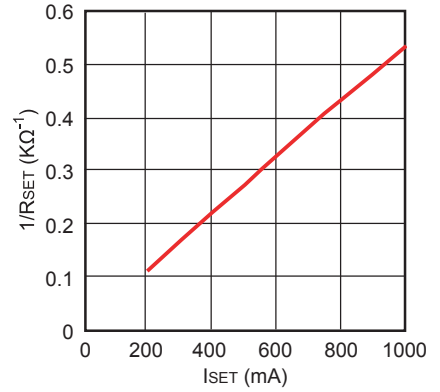

Shut Down Low

$V_{IN} = 5V$, I_{SET} Resistor = 2.26K

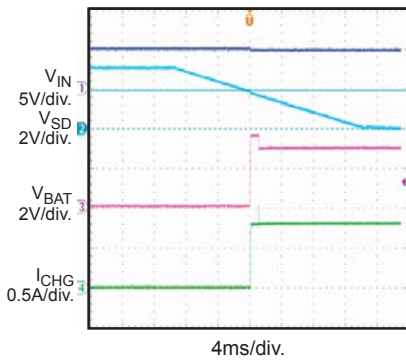

Shut Down High

$V_{IN} = 5V$, I_{SET} Resistor = 2.26K
 $V_{BAT} = 3.8V$

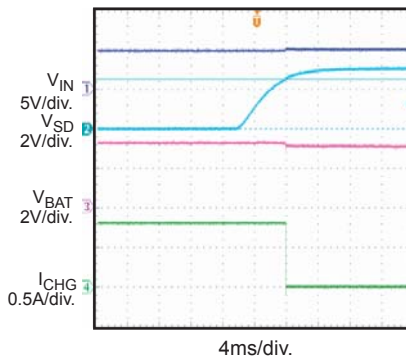

Power Ramp Up

$V_{IN} = 5V$, I_{SET} Resistor = 2.26K

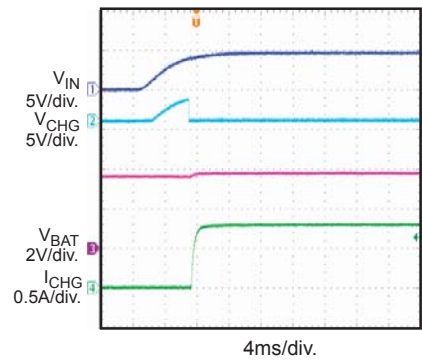

TYPICAL PERFORMANCE CURVES (continued)

$C_{IN} = 4.7\mu F$, $C_{OUT} = 2.2\mu F$, $V_{IN} = 5V$, $T_A = +25^\circ C$, unless otherwise noted.

Power Ramp Down

$V_{IN} = 5V$, I_{SET} Resistor = 2.26K

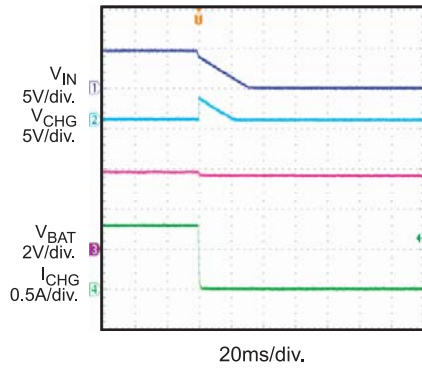

Charge Full Terminated

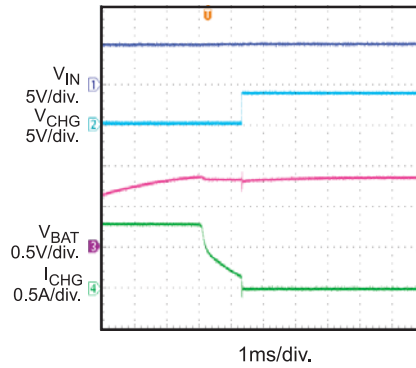

Terminated To Re-Charge

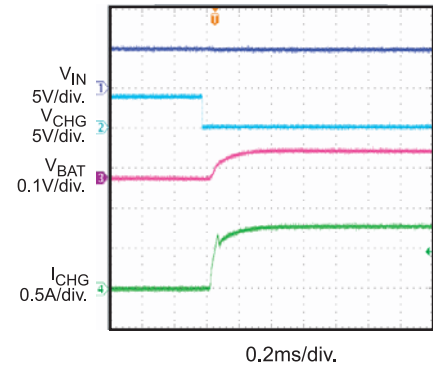

ACOK and CHG Internal Zenor Diode Characteristics

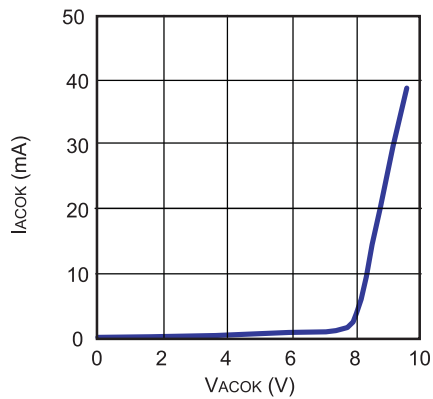

Voltage Charge vs. Temperature

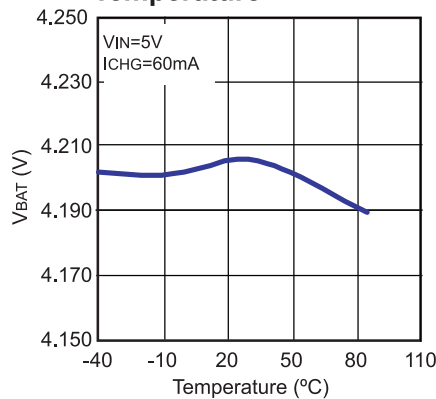

Current Charge vs. Temperature

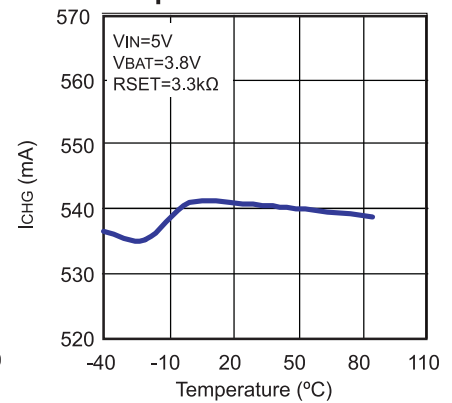

OPERATION

Input Voltage Range

The MP2605 has built-in input voltage surge protection as high as +28V. The charger IC will be automatically disabled when the input voltage is lower than 3.0V or higher than 7.0V. The open-drain pin \overline{ACOK} is used to indicate an input power good condition (i.e. $3.0V < V_{IN} < 7.0V$). If the input voltage is lower than the battery voltage, the IC is also disabled to prevent the battery from draining.

Charge Cycle (Mode Change: Trickle -> CC-> CV)

Figure 2 shows the typical charging profile for the MP2605. For a fully depleted battery with a terminal voltage lower than 2.6V, the MP2605 will start with the trickle charge (preconditioning) at 10% of the full charge current based on the value of R_{CHG} . If the charger stays in trickle mode longer than 32768 cycles, the battery fault condition will be indicated by flashing the \overline{CHG} LED. After the battery voltage reaches 2.6V, the charger begins charging using the programmed charge current (I_{CHG}). This is referred to as Constant Current (CC) mode. Once the battery voltage reaches 4.2V, the charger will operate in the constant voltage (CV) mode until the battery is fully charged. The charge current drops during CV mode, and the battery full indication is set when the charge current is reduced to 20% of the programmed constant current value (I_{CHG}). The charge process is then terminated. Recharge will start after the battery voltage is reduced to 4.0V. After 262144 cycles of continuous charging, if the battery still has not reached 20% of the I_{CHG} condition, the on-chip timer will terminate the charger to prevent charging the dead battery excessively and the fault condition will be flagged by flashing the \overline{CHG} LED.

Charge Termination

The charge current will gradually decrease in CV mode as the battery approaches full. The

battery full threshold is internally programmed to be 20% of the I_{CHG} . When the charge current reaches this threshold, the charger IC will be automatically turned off.

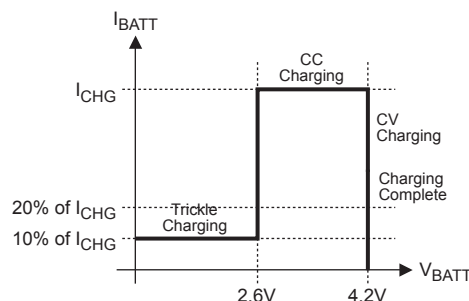

Figure 2—MP2605 Typical Charging Profile

Automatic Recharge

When V_{BATT} drops to 4.0V, the charger will automatically restart the charge cycle until the 20% I_{CHG} condition is met again. When the input adapter is unplugged, or the charger is disabled and/or terminated, the leakage current from the battery to the MP2605 is less than 1uA.

Programming of Charge Current and Battery Full Current

The charge current (I_{CHG}) is set by a resistor (R_{CHG}) connected from the ISET pin to GND, $R_{CHG}(k\Omega) = 1700 / I_{CHG}(mA)$.

The relationship between the charge current and the programming resistance is established by the following table and graph.

Table 1— R_{CHG} and I_{CHG} Relationship

R_{CHG} (k Ω)	I_{CHG} (mA)
1.65	1000
1.82	900
2.05	800
2.32	700
2.74	600
3.3	500
4.12	400
5.6	300
8.45	200
15	100

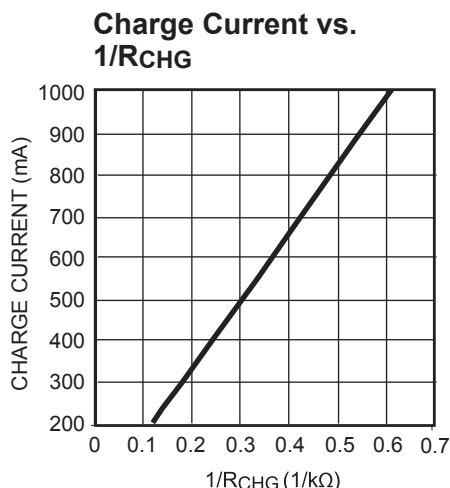

Figure 3—Charge Current vs. 1/R_{CHG} Resistance

The recommended resistance for programming the charge current is $2.3k\Omega < R_{CHG} < 11k\Omega$. The open-drain pin \overline{CHG} is used to indicate charging status. When the battery full condition is met or any other condition prevents the charger from charging, \overline{CHG} status will follow the Table 2.

Negative Thermal Coefficient (NTC) Thermistor

The MP2605 has a built-in NTC resistance window comparator. If configured as the typical application circuit as indicated in Figure 1, the MP2605 will cease charging if $R_{NTC} < 32.3k\Omega$ or $R_{NTC} > 376.6k\Omega$. This represents a valid charging temperature range of 0°C to 50°C for the TH11-4H104F NTC resistor.

Timer Operation

The TMR pin is used to set the internal oscillator frequency, $F_{OSC} = 11Hz \times \frac{\mu F}{C_{TMR}}$. The

on-chip timer will start to count down after initial power-up or every time it is enabled. This timer will limit the max trickle-charge time to 32768 internal oscillating cycles. If the charger stays in trickle mode for longer than 32768 cycles, it will be terminated and a fault state will be set to \overline{CHG} pin. After fault reporting, the charger can be re-initiated only by recycling the power supply or SHDN signal. If the charger successfully goes through trickle charge within the allowed time limit, it will start CC charging and then CV charging. If the total charge time exceeds 262144 cycles and the battery full has not been qualified, the charger will be terminated and a fault will also be set by flashing \overline{CHG} pin at the rate of half the internal oscillation frequency. This function prevents charging a dead battery for prolonged duration. The timer function can be disabled by shorting TMR to ground.

Thermal Protection

The MP2605 has proprietary thermal protection to prevent the IC from overheating. When in thermal protection mode, the average charge current will be reduced to prevent the IC from overheating. Operating in thermal protection mode will slow down the charging process. Lowering the input voltage and enhancing thermal dissipation to the environment can effectively prevent the IC from going into thermal protection mode.

Charger Status Indication

The MP2605 has an integrated charge status pin that remains low while the battery is charging. Once the charge current threshold (I_{BF}) is reached, the \overline{CHG} pin will become high impedance.

For different operation state, \overline{CHG} indication is as Table 2 shows.

Under full charge conditions, certain systems may draw a very narrow current pulse that exceeds the I_{BF} threshold. The \overline{CHG} indicator may glitch. It is desirable to blank the \overline{CHG} glitch so that the system can properly indicate full charge conditions to the user. A simple solution is to add a RC filter on the \overline{CHG} pin to filter out the possible \overline{CHG} glitch, as shown in Figure 4.

Table 2— \overline{CHG} Indication for different Charge State

	SHDN = High Vin Fault	Battery Full	Time out Fault	In Charging
\overline{CHG}	HIGH	HIGH	Toggled at the frequency $\frac{11 \times 10^{-6}}{C_{TMR}(\mu F)}$ Hz	LOW

\overline{ACOK} is LOW while $3.0V < V_{IN} < 7V$, otherwise it is HIGH.

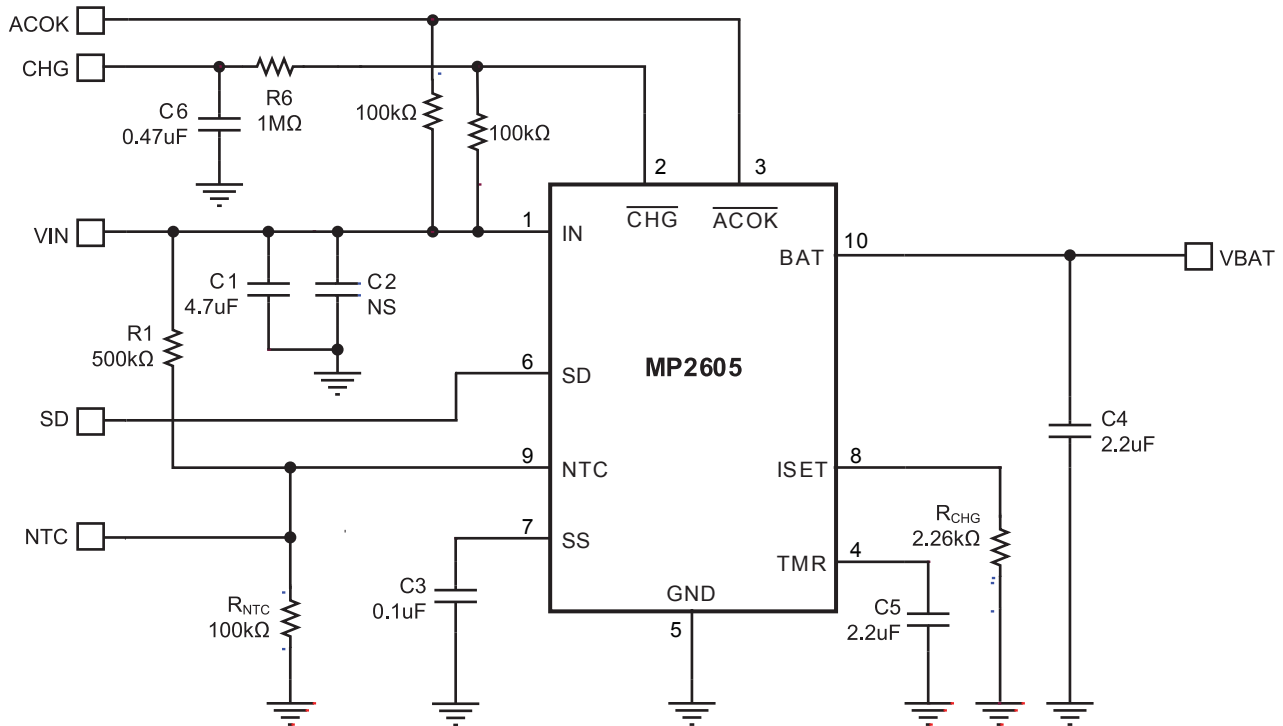

Figure 4—Filtered Charge Status with GPIO Connection

APPLICATION

Flow Chart of Operation

Power-On Reset (POR) feature can be applied to the MP2605 to ensure that the device starts operating in a known state. The flow chart in

Figure 5 describes the conditions and operation modes of the MP2605. CVC and CCC stand for “constant voltage charge” and “constant current charge”, respectively.

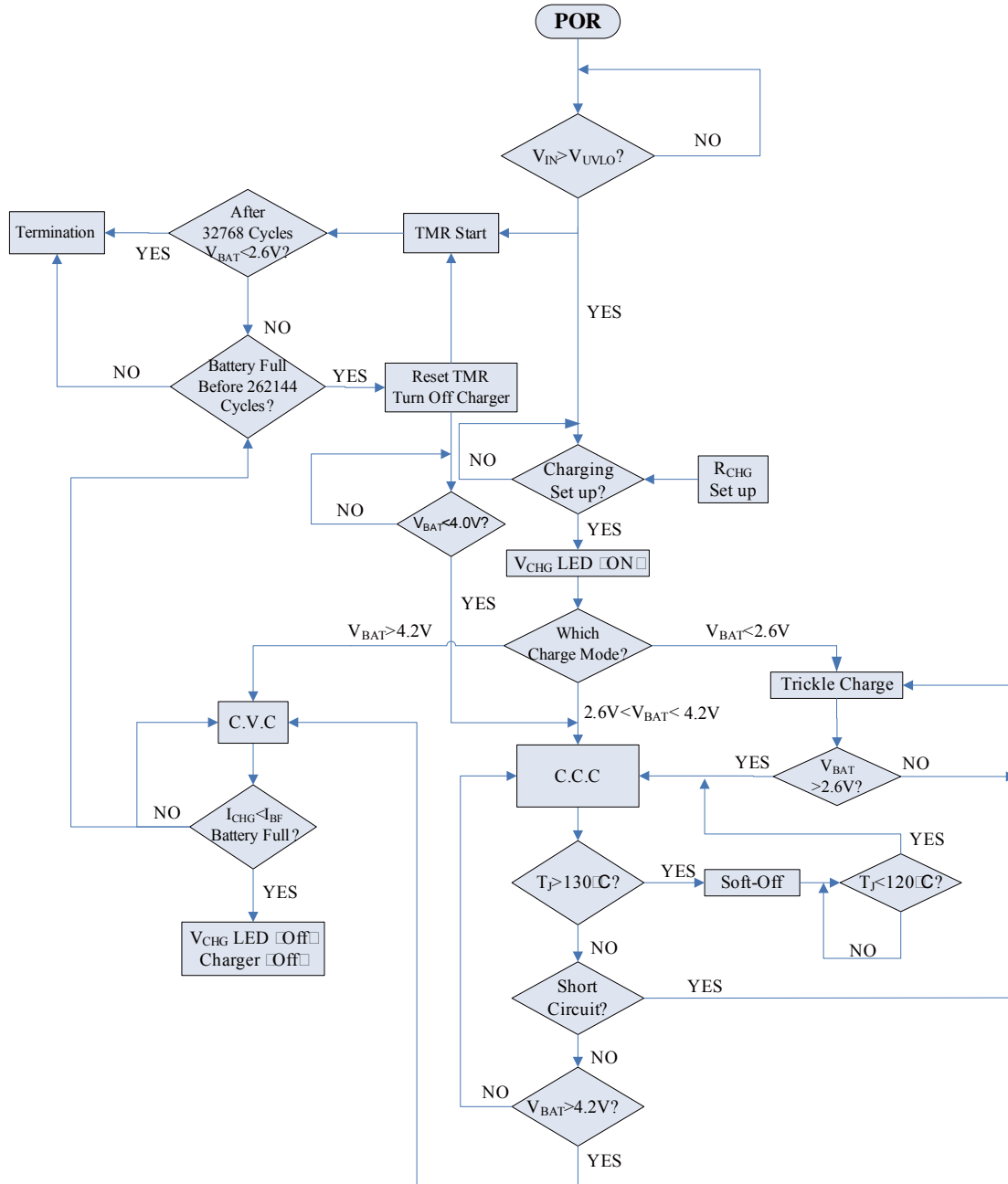
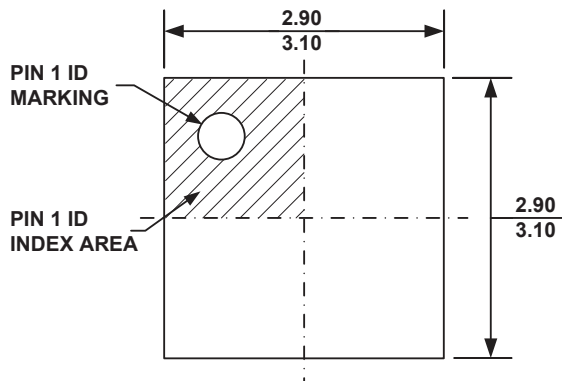

Figure 5—Flow Chart of Operation

PACKAGE INFORMATION

QFN10 (3mm x 3mm)



TOP VIEW

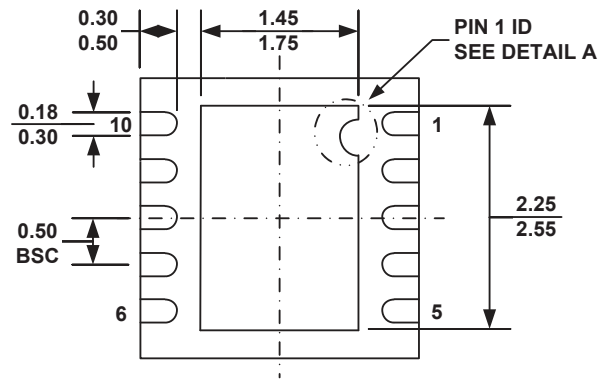

BOTTOM VIEW

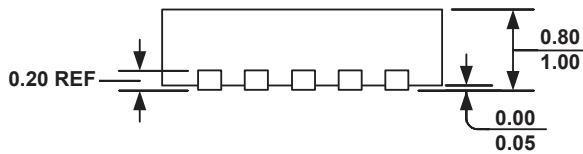

SIDE VIEW

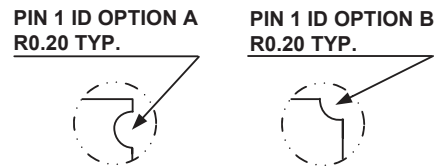

DETAIL A

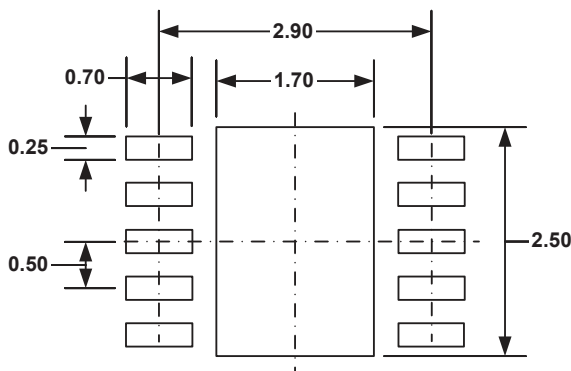

RECOMMENDED LAND PATTERN

NOTE:

- 1) ALL DIMENSIONS ARE IN MILLIMETERS.
- 2) EXPOSED PADDLE SIZE DOES NOT INCLUDE MOLD FLASH.
- 3) LEAD COPLANARITY SHALL BE 0.10 MILLIMETER MAX.
- 4) DRAWING CONFORMS TO JEDEC MO-229, VARIATION VEED-5.
- 5) DRAWING IS NOT TO SCALE.

NOTICE: The information in this document is subject to change without notice. Users should warrant and guarantee that third party Intellectual Property rights are not infringed upon when integrating MPS products into any application. MPS will not assume any legal responsibility for any said applications.