

DESCRIPTION

The MP2420 is a step-down switching regulator with integrated high- and low-side, high-voltage power MOSFETs. It achieves a highly efficient output of up to 0.3A, and the integrated watchdog adds additional security redundancy to the system.

The wide 4.5V to 75V input range accommodates a variety of step-down applications in an automotive environment. A 5µA shutdown mode quiescent current in a full temperature range is ideal for battery-powered applications.

The MP2420 allows for high-power conversion efficiency over a wide load range by scaling down the switching frequency under light-load conditions to reduce switching and gate driver losses. The start-up switching frequency and short circuit can also be scaled down to prevent an inductor current runaway.

Full protection features include under-voltage lockout (UVLO) and thermal shutdown. Thermal shutdown provides reliable, fault-tolerant operation.

The MP2420 is available in a TSSOP-16 EP package.

FEATURES

- 20µA Quiescent Current for Buck Only
- Wide 4.5V to 75V Operating Input Range (80V ABS MAX)
- 1.2Ω/0.45Ω Internal Power MOSFETs
- Programmable Soft Start
- FB Tolerance: 1% at Room Temperature, 2% at Full Temperature
- Adjustable Output Voltage
- Integrated Window Watchdog
- Power-On Reset during Power Up and Under-Voltage Lockout (UVLO)
- Programmable Short Window Mode or Long Window Mode
- Low Shutdown Mode Current of 5µA
- Available in a TSSOP-16 EP Package

APPLICATIONS

- Automotive Systems
- Industrial Power Systems
- Distributed Power Systems
- Battery-Powered Systems

All MPS parts are lead-free, halogen-free, and adhere to the RoHS directive. For MPS green status, please visit the MPS website under Quality Assurance. "MPS" and "The Future of Analog IC Technology" are registered trademarks of Monolithic Power Systems, Inc.

TYPICAL APPLICATION

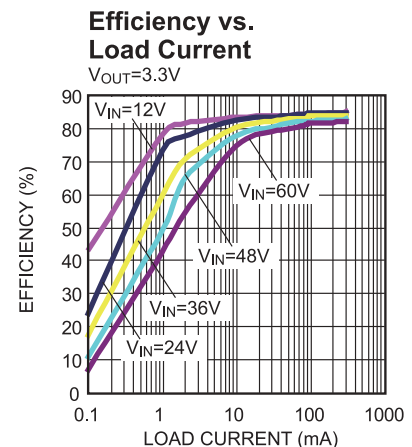
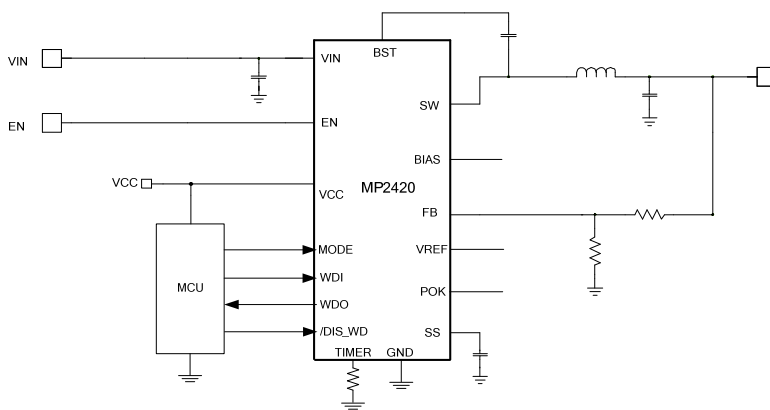

ORDERING INFORMATION

Part Number*	Package	Top Marking
MP2420GF	TSSOP-16 EP	<i>See Below</i>

* For Tape & Reel, add suffix -Z (e.g. MP2420GF-Z)

TOP MARKING

MPSYYWW

MP2420

LLLLLL

MPS: MPS prefix
 YY: Year code
 WW: Week code
 MP2420: Part code of MP2420GF
 LLLLLL: Lot number

PACKAGE REFERENCE

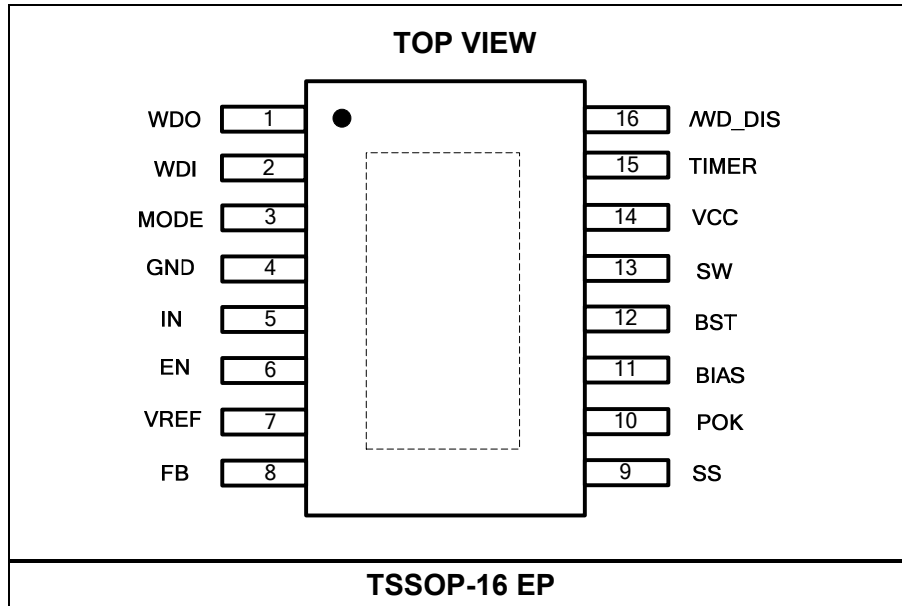

ABSOLUTE MAXIMUM RATINGS ⁽¹⁾

Supply voltage (V_{IN})-0.3V to +80V
Switch voltage (V_{SW})-0.3V to $V_{IN} + 1V$
BST to SW-0.3 to +6.0V
All other pins-0.3V to +6.0V
EN sink current150 μ A
Continuous power dissipation ($T_A = +25^\circ\text{C}$)	⁽²⁾
TSSOP-16 EP2.7W
Junction temperature150 $^\circ\text{C}$
Lead temperature260 $^\circ\text{C}$
Storage temperature -65 $^\circ\text{C}$ to +150 $^\circ\text{C}$

Recommended Operating Conditions ⁽³⁾

Supply voltage (V_{IN})4.5V to 75V
Output voltage (V_{OUT})1V to $0.9 \times V_{IN}$
Operating junction temp. (T_J) -40 $^\circ\text{C}$ to 125 $^\circ\text{C}$

Thermal Resistance ⁽⁴⁾	θ_{JA}	θ_{JC}
TSSOP-16 EP4510

NOTES:

- 1) Exceeding these ratings may damage the device.
- 2) The maximum allowable power dissipation is a function of the maximum junction temperature T_J (MAX), the junction-to-ambient thermal resistance θ_{JA} , and the ambient temperature T_A . The maximum allowable continuous power dissipation at any ambient temperature is calculated by P_D (MAX) = $(T_J$ (MAX) - T_A) / θ_{JA} . Exceeding the maximum allowable power dissipation produces an excessive die temperature, causing the regulator to go into thermal shutdown. Internal thermal shutdown circuitry protects the device from permanent damage.
- 3) The device is not guaranteed to function outside of its operating conditions.
- 4) Measured on JESD51-7, 4-layer PCB.

ELECTRICAL CHARACTERISTICS

$V_{IN} = 24V$, $V_{EN} = 2V$, $V_{CC} = 5V$, $T_J = +25^{\circ}C$, unless otherwise noted.

Parameter	Condition	Min	Typ	Max	Units
DC/DC Converter					
Supply quiescent current	No load, $V_{FB} = 1.2V$		20	25	μA
Shutdown supply current	$V_{EN} < 0.3V$		2.2	3.5	μA
V_{IN} UVLO rising threshold		3.9	4.2	4.4	V
V_{IN} UVLO falling threshold		3.45	3.75	3.95	
V_{IN} UVLO hysteresis			0.45		V
Feedback voltage	$V_{IN} = 4.5V$ to $75V$, $T_J = 25^{\circ}C$	0.99	1.0	1.01	V
	$V_{IN} = 4.5V$ to $75V$, $-40^{\circ}C < T_J < 125^{\circ}C$	0.98	1.0	1.02	V
Feedback current	$V_{FB} = 1.2V$	-50	2	50	nA
V_{REF} voltage	$V_{IN} = 4.5V$ to $75V$, $I_{REF} = 100\mu A$	0.965	1	1.035	V
Upper switch-on resistance	$V_{BST} - V_{SW} = 5V$	0.9	1.2	1.5	Ω
Lower switch-on resistance	$V_{BIAS} = 5V$	0.275	0.45	0.625	Ω
Lower switch leakage	$V_{EN} = 0V$, $V_{SW} = 75V$			1	μA
Peak current limit		670	730	790	mA
Minimum switch-on time ⁽⁵⁾			120		ns
Enable rising threshold		1.25	1.55	1.85	V
Enable falling threshold		1.152	1.2	1.248	V
Enable threshold hysteresis			0.35		V
Enable current	$V_{EN} = 2.4V$		0.8		μA
Soft-start current		4	5.5	7	μA
POK upper trip threshold	FB respect to the nominal value	86	90	94	%
POK lower trip threshold	FB respect to the nominal value	81	85	89	%
POK threshold hysteresis	FB respect to the nominal value		5		%
POK deglitch timer			40		μs
POK output voltage low	$I_{SINK} = 1mA$			0.4	V
FB OVP rising threshold			1.05	1.1	V
FB OVP hysteresis			50		mV
Thermal shutdown ⁽⁵⁾			175		$^{\circ}C$
Thermal shutdown hysteresis ⁽⁵⁾			20		$^{\circ}C$

NOTE:

5) Derived from bench characterization. Not tested in production.

ELECTRICAL CHARACTERISTICS (continued)
 $V_{IN} = 24V$, $V_{EN} = 2V$, $V_{CC} = 5V$, $T_J = 25^{\circ}C$, unless otherwise noted.

Parameter	Symbol	Condition	Min	Typ	Max	Units
Watchdog Power Supply						
Timer voltage		$R_{TIMER} = 51k$		0.3		V
Quiescent current	I_Q	$R_{TIMER} = 100k$		16	19	μA
		$R_{TIMER} = 51k$		25	32	μA
Power-on reset threshold	$V_{POR-HIGH}$	WDO goes high with rising V_{CC}	4.4	4.6	4.8	V
	$V_{POR-LOW}$	WDO goes low with falling V_{CC}	4.3	4.5	4.7	V
Watchdog Timing						
Single period	T	$R_{TIMER} = 51k$	-10%	880	+10%	μs
Power-on delay ⁽⁶⁾	t_0	$R_{TIMER} = 51k$		10		cycle
Sync signal monitoring time ⁽⁶⁾	t_1	$R_{TIMER} = 51k$		450		cycle
Watchdog window close time (short mode) ⁽⁶⁾	t_2	$R_{TIMER} = 51k$, mode = low		15		cycle
Watchdog window open time (short mode) ⁽⁶⁾	t_3	$R_{TIMER} = 51k$, mode = low		10		cycle
Watchdog window close time (long mode) ⁽⁶⁾	t_4	$R_{TIMER} = 51k$, mode = high		1500		cycle
Watchdog window open time (long mode) ⁽⁶⁾	t_5	$R_{TIMER} = 51k$, mode = high		1000		cycle
WDO reset pulse width ⁽⁶⁾	t_6	$R_{TIMER} = 51k$		4		cycle
WDI_OK pulse width			10		5000	μs
Watchdog Input and Output						
WDI logic high			3.2			V
WDI logic low					0.8	V
MODE logic high			3.2			V
MODE logic low					0.8	V
MODE input current		MODE = 5V		0.1	1	μA
		MODE = 0V		5	8	μA
$\overline{WD_DIS}$ logic high			3.2			V
$\overline{WD_DIS}$ logic low					0.8	V
$\overline{WD_DIS}$ input current		WD_DIS = 5V		0.1	1	μA
		WD_DIS = 0V		5	8	μA
WDO high		$V_{CC} = 5V$, $I_{WDO} = 1mA$	$V_{CC}-0.2$			V
WDO low		$V_{CC} = 5V$, $I_{WDO} = 1mA$			0.2	V
		$V_{CC} = 1V$, $I_{WDO} = 300\mu A$			0.1	V

NOTE:

6) Guaranteed by design.

TYPICAL CHARACTERISTICS

DC/DC CONVERTER

$V_{IN} = 12V$, unless otherwise noted.

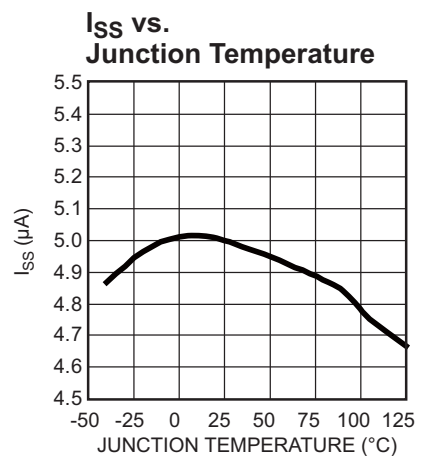
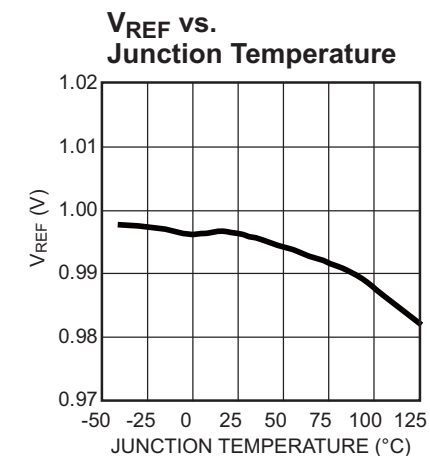
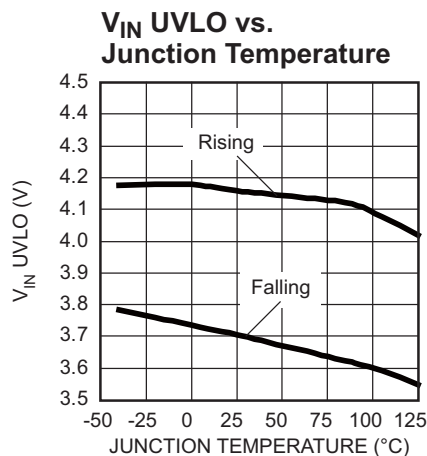
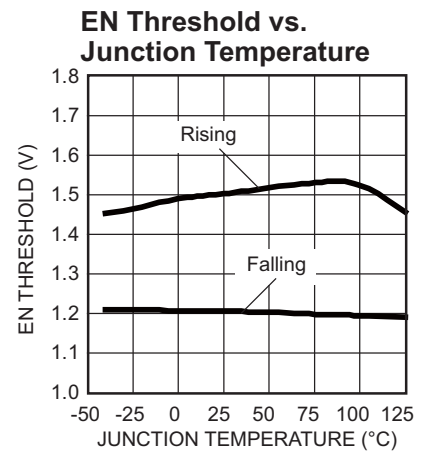
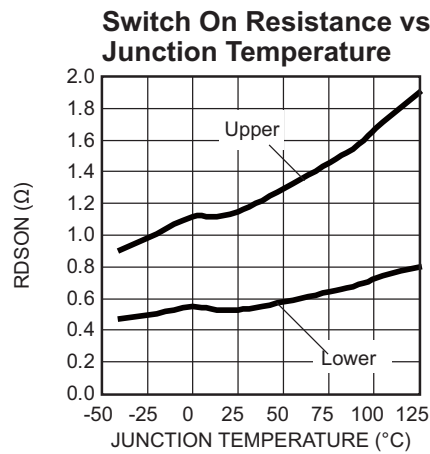
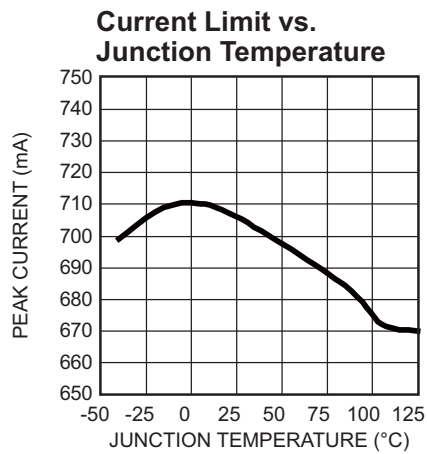
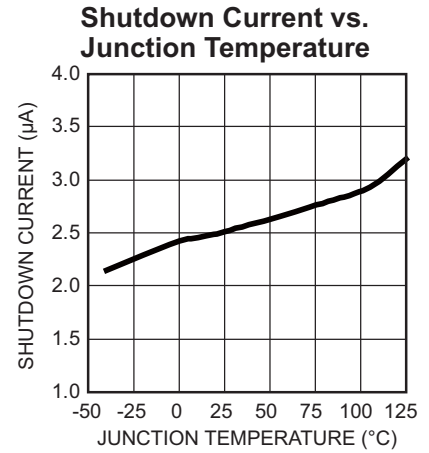
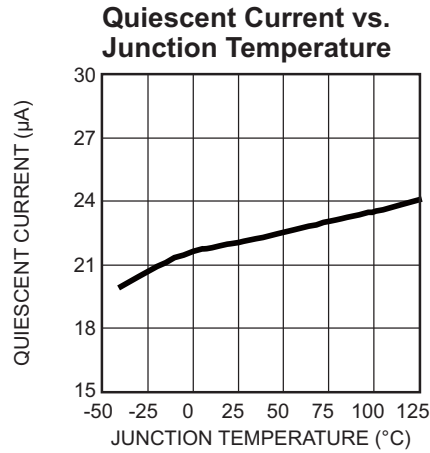
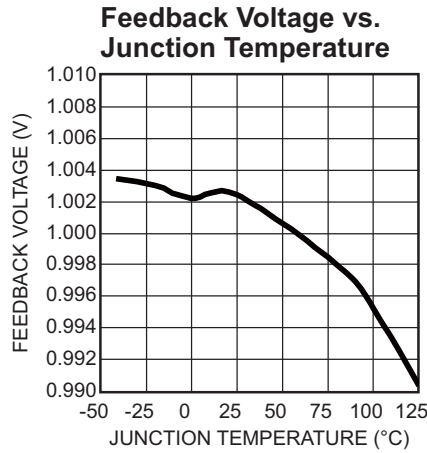

TYPICAL CHARACTERISTICS (continued)
WATCHDOG

Quiescent Current vs. Junction Temperature

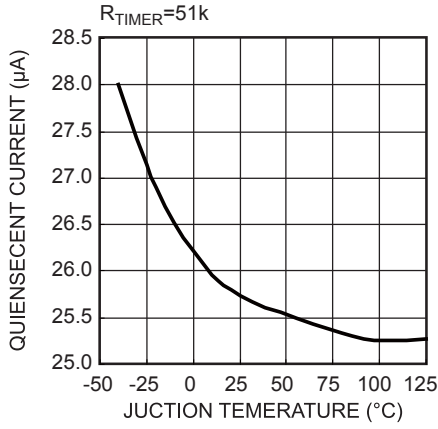

Quiescent Current vs. Junction Temperature

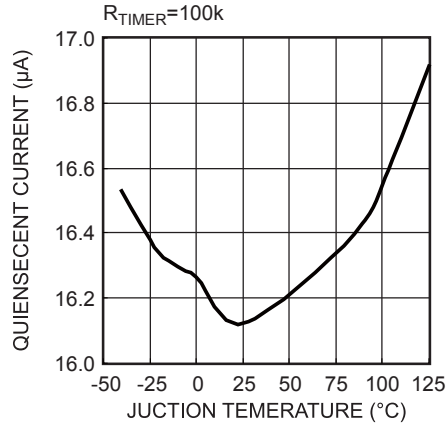

Single Period vs. Junction Temperature

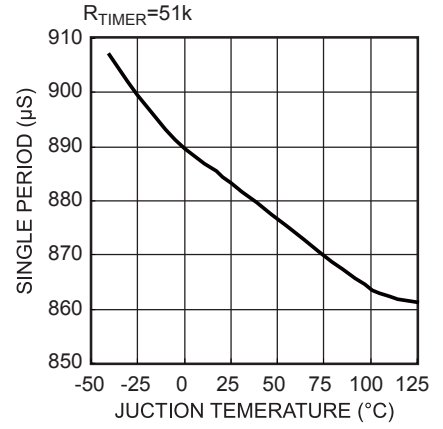

Single Period vs. RTIMER

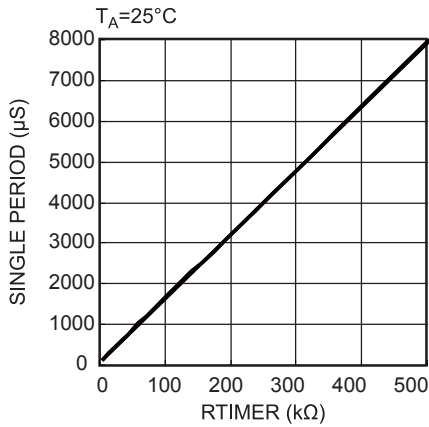

TYPICAL PERFORMANCE CHARACTERISTICS

DC-DC CONVERTER

$V_{IN} = 12V$, $V_{OUT} = 3.3V$, $L = 33\mu H$, $C_{OUT} = 2 \times 22\mu F$, $T_A = 25^\circ C$, unless otherwise noted.

Efficiency vs. Load Current

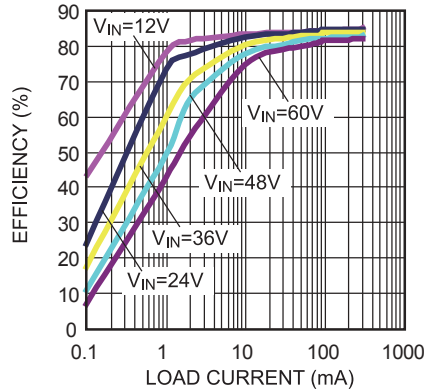

Load Regulation

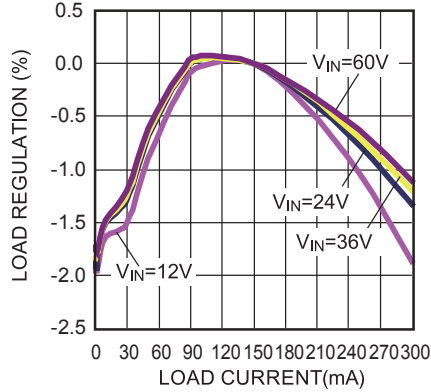

Line Regulation

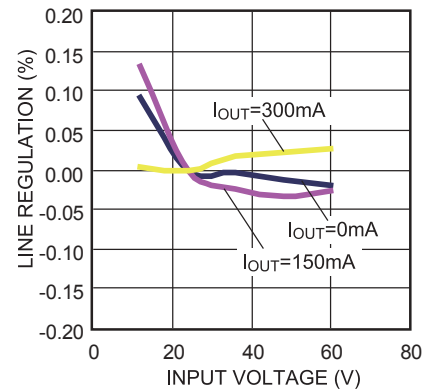

Steady State

$I_{OUT} = 0A$

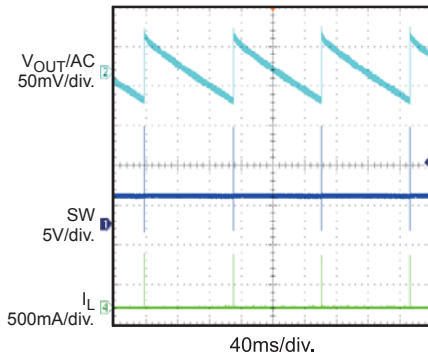

Steady State

$I_{OUT} = 0.3A$

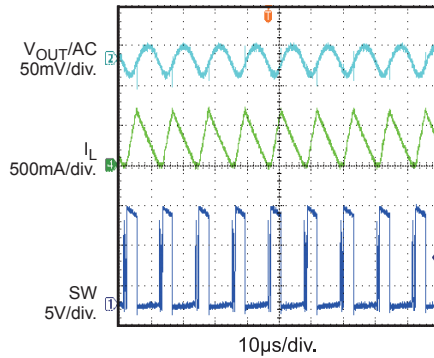

Start-Up through V_{IN}

$I_{OUT} = 0A$

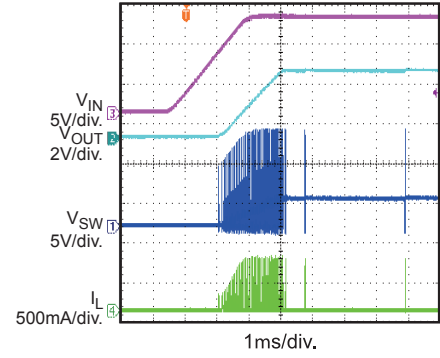

Startup through V_{IN}

$I_{OUT} = 0.3A$

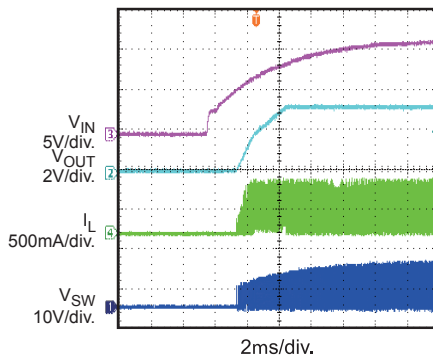

Shutdown through V_{IN}

$I_{OUT} = 0A$

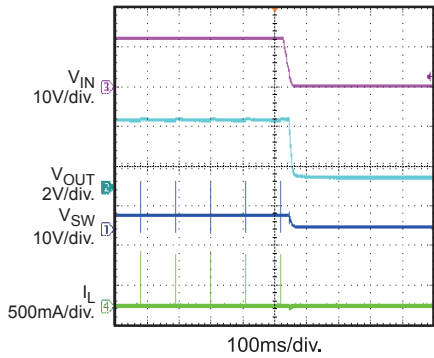

Shutdown through V_{IN}

$I_{OUT} = 0.3A$

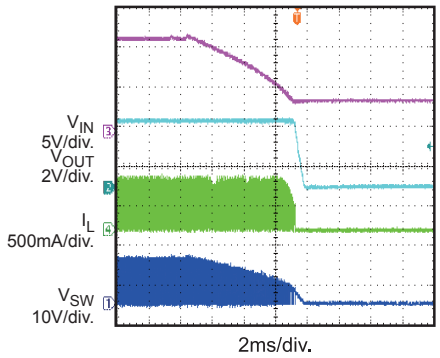

TYPICAL PERFORMANCE CHARACTERISTICS (continued)

$V_{IN} = 12V$, $V_{OUT} = 3.3V$, $L = 33\mu H$, $C_{OUT} = 2 \times 22\mu F$, $T_A = 25^\circ C$, unless otherwise noted.

Start-Up through EN
 $I_{OUT} = 0A$

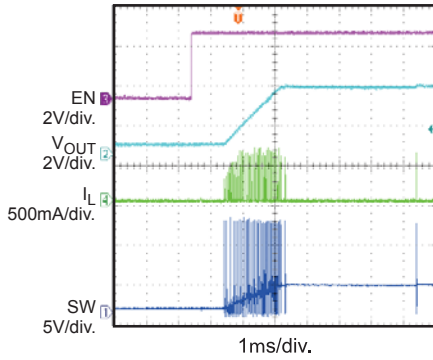

Start-Up through EN
 $I_{OUT} = 0.3A$

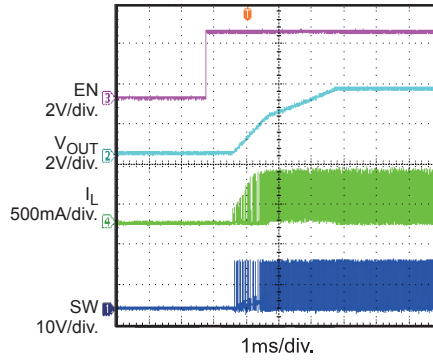

Shutdown through EN
 $I_{OUT} = 0A$

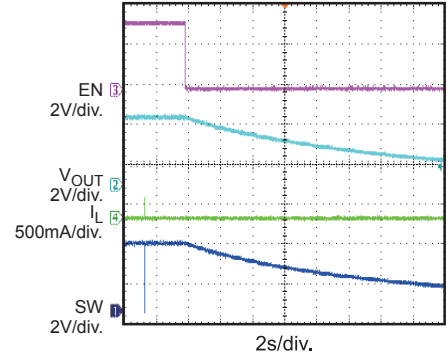

Shutdown through EN
 $I_{OUT} = 0.3A$

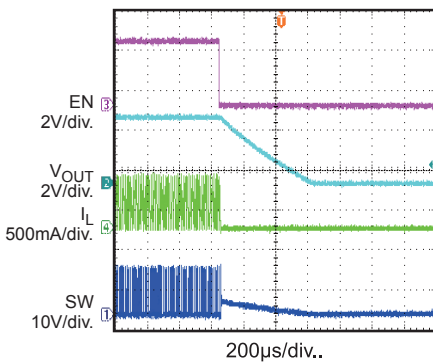

SCP Entry
 $I_{OUT} = 0A$ to Short Circuit

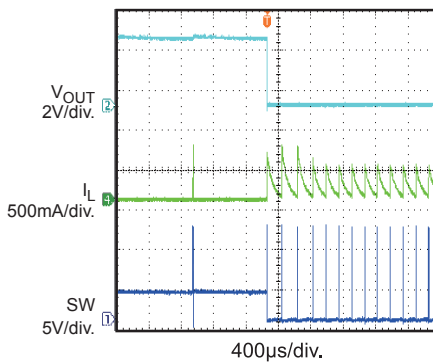

SCP Entry
 $I_{OUT} = 0.3A$ to Short Circuit

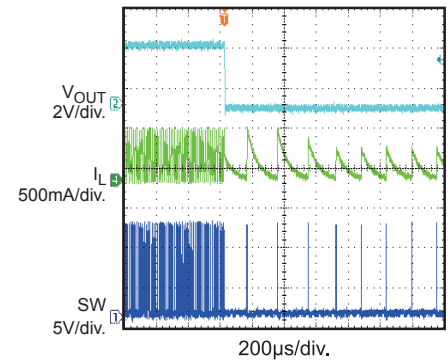

SCP Steady State

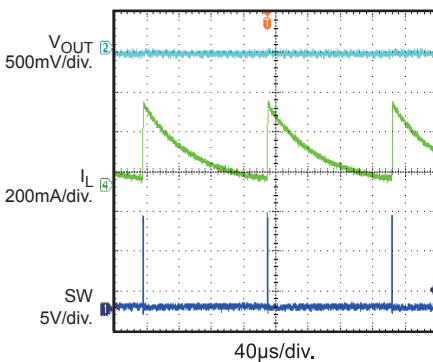

SCP Recovery
Short Circuit to $I_{OUT} = 0A$

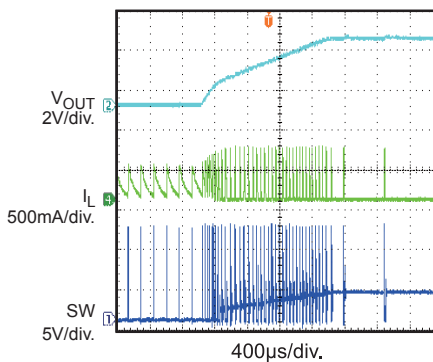

SCP Recovery
Short Circuit to $I_{OUT} = 0.3A$

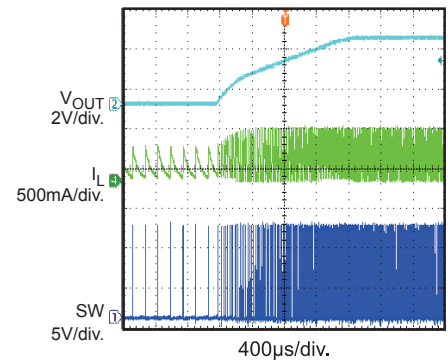

PIN FUNCTIONS

Pin #	Name	Description
Watchdog		
1	WDO	Watchdog output. WDO outputs the reset signal to the MCU.
2	WDI	Watchdog input. WDI receives the trigger signal from the MCU.
3	MODE	Mode switching. Pull MODE high to make the watchdog work in long window mode; pull MODE low to make the watchdog work in short window mode. MODE has a weak internal pull-up.
4	GND	Ground. Connect GND as close the output capacitor as possible to avoid high-current switch paths.
14	VCC	Power input.
15	TIMER	Watchdog timer. Set the time-out with an external resistor.
16	/WD_DIS	Watchdog disable. Pull /WD_DIS low to disable the watchdog; pull /WD_DIS high to enable the watchdog. /WD_DIS has a weak internal pull-up.
DC/DC		
4	GND	Ground. Same as GND in Watchdog.
5	IN	Input supply. IN requires a decoupling capacitor connected to ground to reduce switching spikes.
6	EN	Enable input. Pull EN below the low threshold to shut the chip down; pull EN above the high threshold to enable the chip. Float EN to shut the chip down.
7	VREF	Reference voltage output.
8	FB	Feedback input to the error amplifier (for QFN-10 (3mmx3mm) package only). Connect FB to the tap of an external resistive divider between output and GND. FB sets the regulation voltage when compared to the internal 1V reference.
9	SS	Soft-start control input. Connect a capacitor from SS to GND to set the soft-start period.
10	POK	Open-drain power good output. A high output indicates that V_{OUT} is higher than 90% of the reference. POK is pulled down during shutdown.
11	BIAS	Controller bias input. BIAS supplies a current to the internal circuit when $V_{BIAS} > 2.9V$. BIAS is the feedback input for the SOIC-8 E package, which has a fixed output only.
12	BST	Bootstrap. BST is the positive power supply for the internal floating high-side MOSFET driver. Connect a bypass capacitor between BST and SW.
13	SW	Switch node.
	Exposed Pad	Connect the exposed pad to the GND plane for optimal thermal performance.

FUNCTIONAL BLOCK DIAGRAM

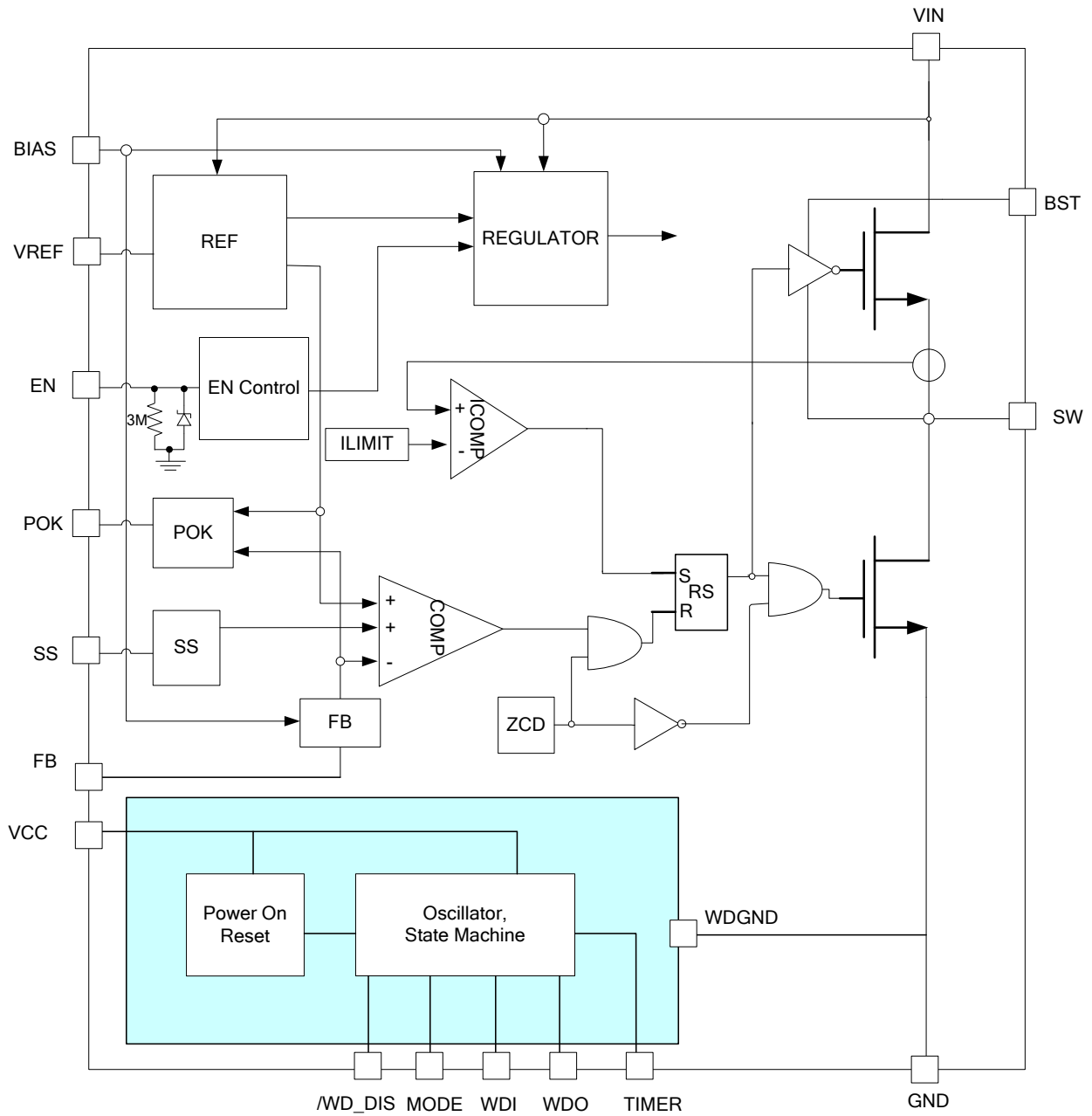

Figure 1: Functional Block Diagram

OPERATION

DC/DC SECTION:

The MP2420 is a 75V, 0.3A, synchronous step-down, switching regulator with integrated high-side and low-side, high-voltage power MOSFETs (HS-FET and LS-FET, respectively). It provides a highly efficient 0.3A output and features a wide input voltage range, external soft-start control, and precision current limit. It has a very low operational quiescent current, making it suitable for battery-powered applications.

Control Scheme

The ILIM comparator, FB comparator, and zero current detector (ZCD) block control the PWM (see Figure 2). If V_{FB} is below the 1V reference and the inductor current drops to zero, the HS-FET turns on, and the ILIM comparator begins sensing the HS-FET current. When the HS-FET current reaches its limit, the HS-FET turns off, and the LS-FET and ZCD block turn on. The ILIM comparator turns off to reduce the quiescent current. The LS-FET and ZCD block turn off after the inductor current drops to zero. If V_{FB} is below the 1V reference at this time, the HS-FET turns on and begins another cycle. If V_{FB} is still higher than the 1V reference, the HS-FET remains off until V_{FB} drops below 1V.

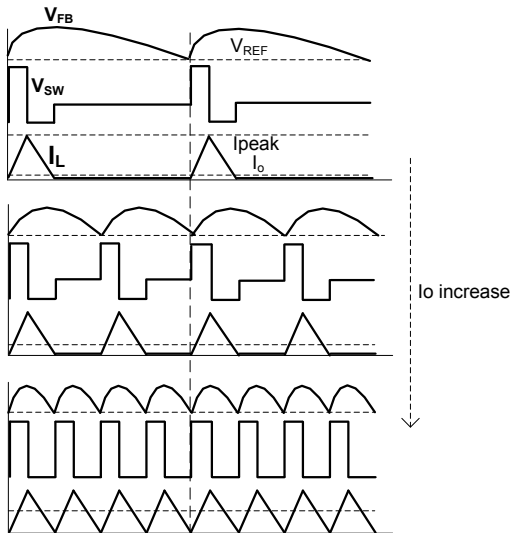

Figure 2: Control Scheme

Internal Regulator and BIAS

The 2.6V internal regulator powers most of the internal circuitry. This regulator takes V_{IN} and operates in the full V_{IN} range. When V_{IN} is greater than 3.0V, the output of the regulator is in full regulation. Lower values of V_{IN} result in lower output voltages. When $V_{BIAS} > 2.9V$, the BIAS supply overrides the input voltage and supplies power to the internal regulator. When $V_{BIAS} > 4.5V$, BIAS powers the LS-FET driver.

Using BIAS to power the internal regulator improves efficiency. It is recommended to connect BIAS to the regulated output voltage when it is in the 2.9V to 5.5V range. When the output voltage is out of this range, an external supply of $>2.9V$ to $>4.5V$ can be used to power BIAS.

Enable (EN) Control

The MP2420 has a dedicated enable control (EN). When V_{IN} goes high, EN enables and disables the chip (high logic). Its falling threshold is a consistent 1.2V, and the rising threshold is about 350mV higher. When floating, EN is pulled down internally to GND to disable the chip.

When $EN = 0V$, the chip enters the lowest shutdown current mode. When EN is higher than zero but lower than its rising threshold, the chip remains in shutdown mode with a slightly larger shutdown current.

A Zener diode is connected internally from EN to GND. The typical clamping voltage of the Zener diode is 6.5V. V_{IN} can be connected to EN through a high ohm (Ω) resistor if the system does not have another logic input acting as the EN signal. The resistor must be designed to limit the EN sink current to less than 150 μ A. Note that there is an internal 3M Ω resistor from EN to GND, so the external pull up resistor should be smaller than $\frac{[V_{IN(MIN)} - 1.55V] \times 3M}{1.55V}$ to ensure that EN can turn on at the lowest operation (V_{IN}).

Under-Voltage Lockout (UVLO)

V_{IN} under-voltage lockout (UVLO) protects the chip from operating below its operational supply voltage range. The UVLO rising threshold is about 4.2V while its trailing threshold is about 3.75V.

Soft Start (SS)

The reference-type soft start prevents the converter output voltage from overshooting during start-up. When the chip starts, the internal circuitry generates a constant current to charge the external soft-start capacitor. The SS voltage ramps up slowly from 0V at a pace set by the SS time. When V_{SS} is less than V_{REF} , V_{SS} overrides V_{REF} , and the FB comparator uses V_{SS} as the reference instead of V_{REF} . When V_{SS} is higher than V_{REF} , V_{REF} resumes control.

V_{SS} can be much smaller than V_{FB} , but it can only barely exceed V_{FB} . If V_{FB} drops, V_{SS} tracks V_{FB} . This function prevents an output voltage overshoot during short-circuit recovery. When the short circuit is removed, a new SS process ramps up.

Thermal Shutdown

Thermal shutdown prevents a thermal runaway on the chip. When the silicon die reaches temperatures exceeding its upper threshold, the entire chip shuts down. When the temperature falls below its lower threshold, the chip is enabled again.

Floating Driver and Bootstrap Charging

The external bootstrap capacitor powers the floating HS-FET driver. This floating driver has its own UVLO protection. This UVLO's rising threshold is about 2.4V with a hysteresis of about 300mV. During the UVLO, the SS voltage resets to zero. When the UVLO is disabled, the regulator follows the soft-start process.

The dedicated internal bootstrap regulator charges and regulates the bootstrap capacitor to about 5V. When the voltage difference between BST and SW falls below its working parameters, a PMOS pass transistor connected from V_{IN} to BST turns on to charge the bootstrap capacitor. The current path runs from V_{IN} to BST to SW. The external circuit must have sufficient voltage headroom to accommodate charging.

As long as V_{IN} is sufficiently higher than SW, the bootstrap capacitor can charge. When the HS-FET is on, V_{IN} is about equal to SW, and the bootstrap capacitor cannot charge. The optimal charging period occurs when the LS-FET is on, and $V_{IN} - V_{SW}$ is at its largest. V_{SW} is equal to V_{OUT} when there is no current in the inductor. The difference between V_{IN} and V_{OUT} charges the bootstrap capacitor.

If the internal circuit does not have sufficient voltage and time to charge the bootstrap capacitor, extra external circuitry can be used to ensure that the bootstrap voltage operates in its normal region.

Start-Up and Shutdown

If both V_{IN} and V_{EN} are higher than their appropriate thresholds, the chip starts up. The reference block starts first, generating stable reference voltages and currents, and then it enables the internal regulator. The regulator provides a stable supply for the rest of the device.

If the internal supply rail is high, an internal timer holds the power MOSFET off for about 50 μ s to clear up any start-up glitches. When the soft-start block is enabled, the SS output voltage is first held low and then slowly ramps up.

Three events can shut down the chip: V_{EN} low, V_{IN} low, and thermal shutdown. During the shutdown procedure, the signaling path is blocked first to avoid any fault triggering. The internal supply rails are then pulled down. The floating driver is not subject to this shutdown command, but its charging path is disabled.

Power OK (POK)

POK is an open-drain power good output. A high output indicates that V_{OUT} is higher than 90% of its nominal value. POK is pulled down in shutdown mode.

Reference Voltage Output (V_{REF})

V_{REF} has an output reference voltage of 1V. It has up to 500 μ A of source current capability.

WATCHDOG SECTION:

Supply Voltage

A supply voltage of $V_{CC} = 5V \pm 10\%$ is recommended for normal operation. WDO is pulled low when V_{CC} rises to 1V or above. After V_{CC} rises to 4.65V, WDO remains at a low level for t_0 to reset the MCU.

Timer

Calculate the period T (μs) with Equation (1):

$$T(\mu s) = 15.75 \times R_{TIMER} (k\Omega) + 73.5 \quad (1)$$

Calculate the R_{TIMER} ($k\Omega$) with Equation (2):

$$R_{TIMER} (k\Omega) = 0.063 \times T(\mu s) - 4.67 \quad (2)$$

For example, if $R_{TIMER} = 51k\Omega$, then $T \approx 0.88ms$.

Monitoring the MCU Synchronization Signal

When the watchdog is in a sync signal monitoring state, the watchdog IC receives a WDI_OK signal from the MCU within t_1 . The timer resets, and the watchdog enters normal operation (WDI remains low for 10 μs to 5ms). If the watchdog does not receive the WDI_OK signal from the MCU during t_1 , it generates a reset signal and enters a sync signal monitor state again.

Short Window Mode

If the MCU and watchdog are synchronized correctly and MODE is low, the watchdog works in a short window mode if WDI_OK is received in a window close state (t_2). The watchdog outputs a reset signal and enters the sync signal monitoring state.

If WDI_OK is received in a window open state (t_3), the watchdog enters a window close state. The MCU is in normal operation in this situation.

If WDI_OK is not received in t_2+t_3 , the watchdog outputs a reset signal and enters the sync signal monitoring state.

MODE is pulled to high during the short window mode, and the watchdog then enters long window mode.

Long Window Mode

If the MCU and watchdog are synchronized correctly and MODE is high, the watchdog works in long window mode if WDI_OK is received in a window close state (t_4). The watchdog outputs a reset signal and enters a sync signal monitoring state.

If WDI_OK is received in a window open state (t_5), the watchdog enters a window close state. The MCU is in normal operation in this situation.

If WDI_OK is not received in t_4+t_5 , the watchdog then outputs a reset signal and enters the sync signal monitoring state.

MODE is pulled low during the long window mode, and the watchdog enters a short window mode.

Watchdog Disable

Pull /WD_DIS low to disable the watchdog, and pull /WD_DIS high to enable the watchdog. It has a weak internal pull-up, so leaving /WD_DIS open enables the watchdog.

WDI Error

The WDI signal remaining at a low level for longer than the max WDI_OK pulse width is regarded as an error. When this error occurs, WDO is pulled down until WDI rises to its high level again.

TIMING DIAGRAM

Power-On Reset and No Sync Signal

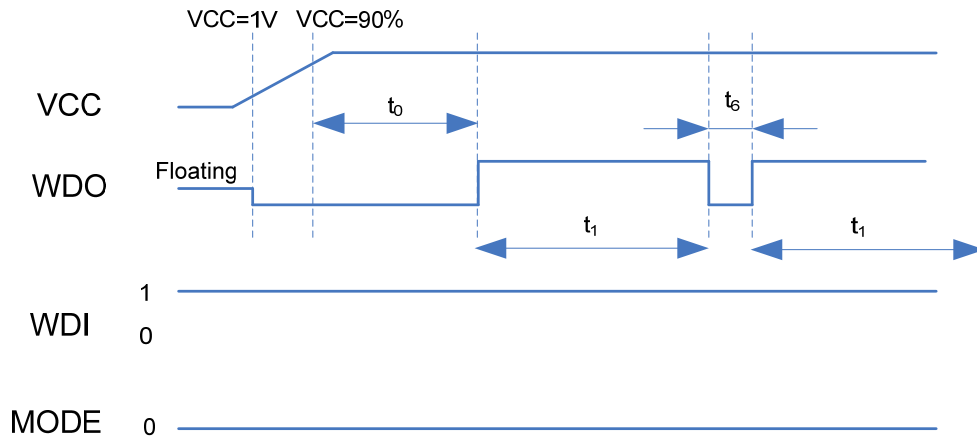

Synchronized by WDI and Triggered in Open Window (MODE = 0, Short Window Mode)

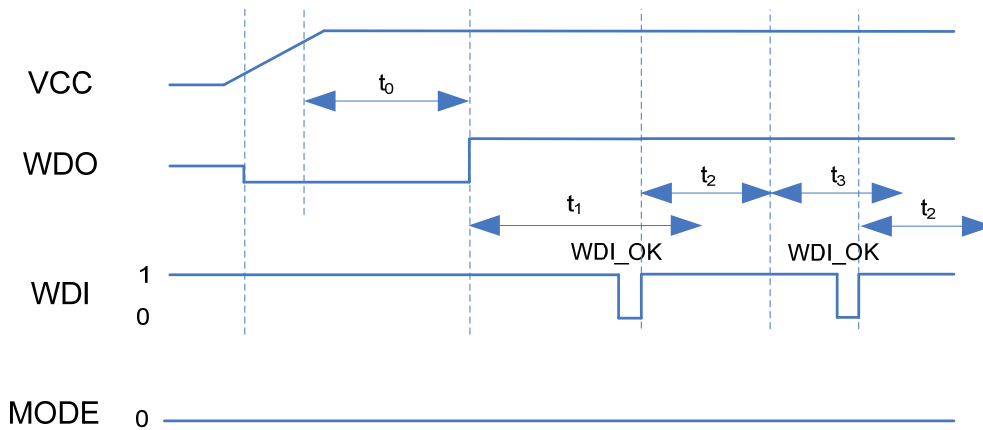

Synchronized by WDI and No Trigger Signal (MODE = 0, Short Window Mode)

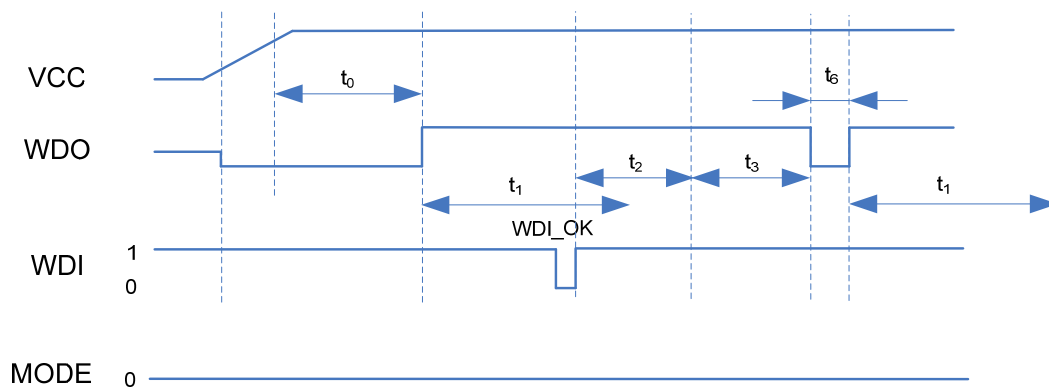

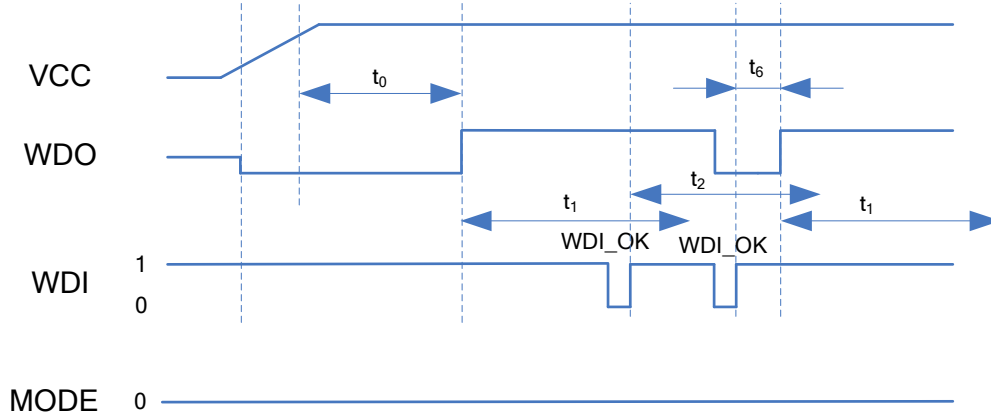
Synchronized by WDI and Triggered in Closed Window (MODE = 0, Short Window Mode)

NOTE: When the WDI_OK rising edge approaches WDO when it is low, the t_6 timer is reset. In the situation above, the WDO reset signal keeps $t_6 + \text{WDI_OK}$ time.

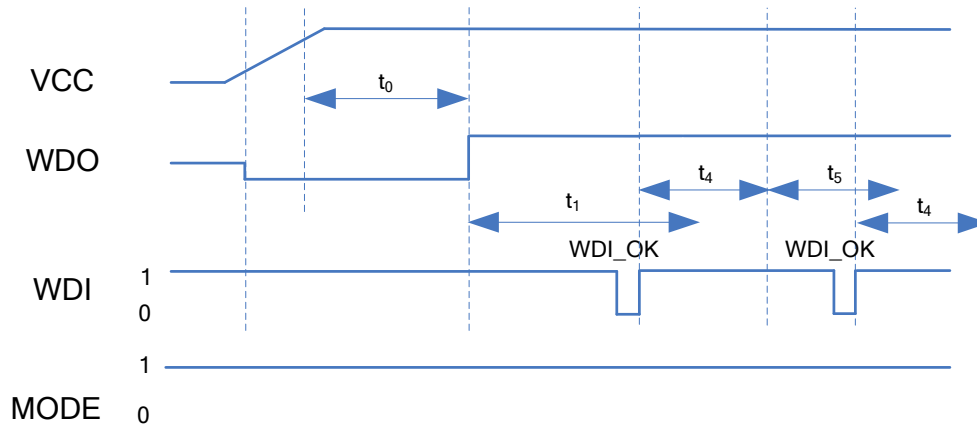
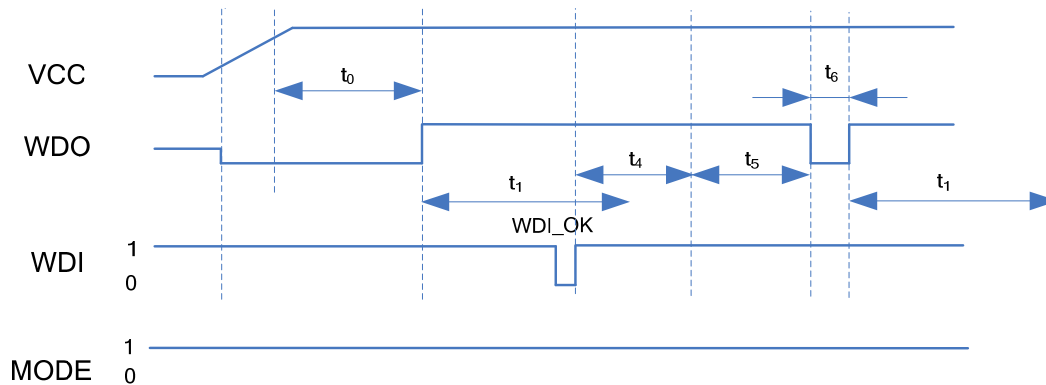
Synchronized by WDI and Triggered in Open Window (MODE = 1, Long Window Mode)

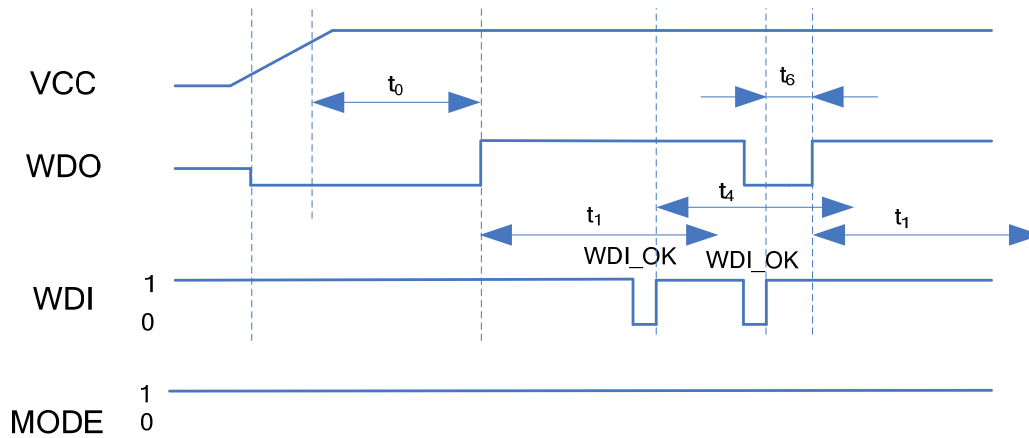
Synchronized by WDI and No Trigger Signal (MODE = 1, Long Window Mode)

Synchronized by WDI and Triggered in Closed Window (MODE = 1, Long Window Mode)

NOTE: When the WDI_OK rising edge approaches WDO when it is low, the t_6 timer is reset. In the situation above, the WDO reset signal keeps $t_6 + \text{WDI_OK}$ time.

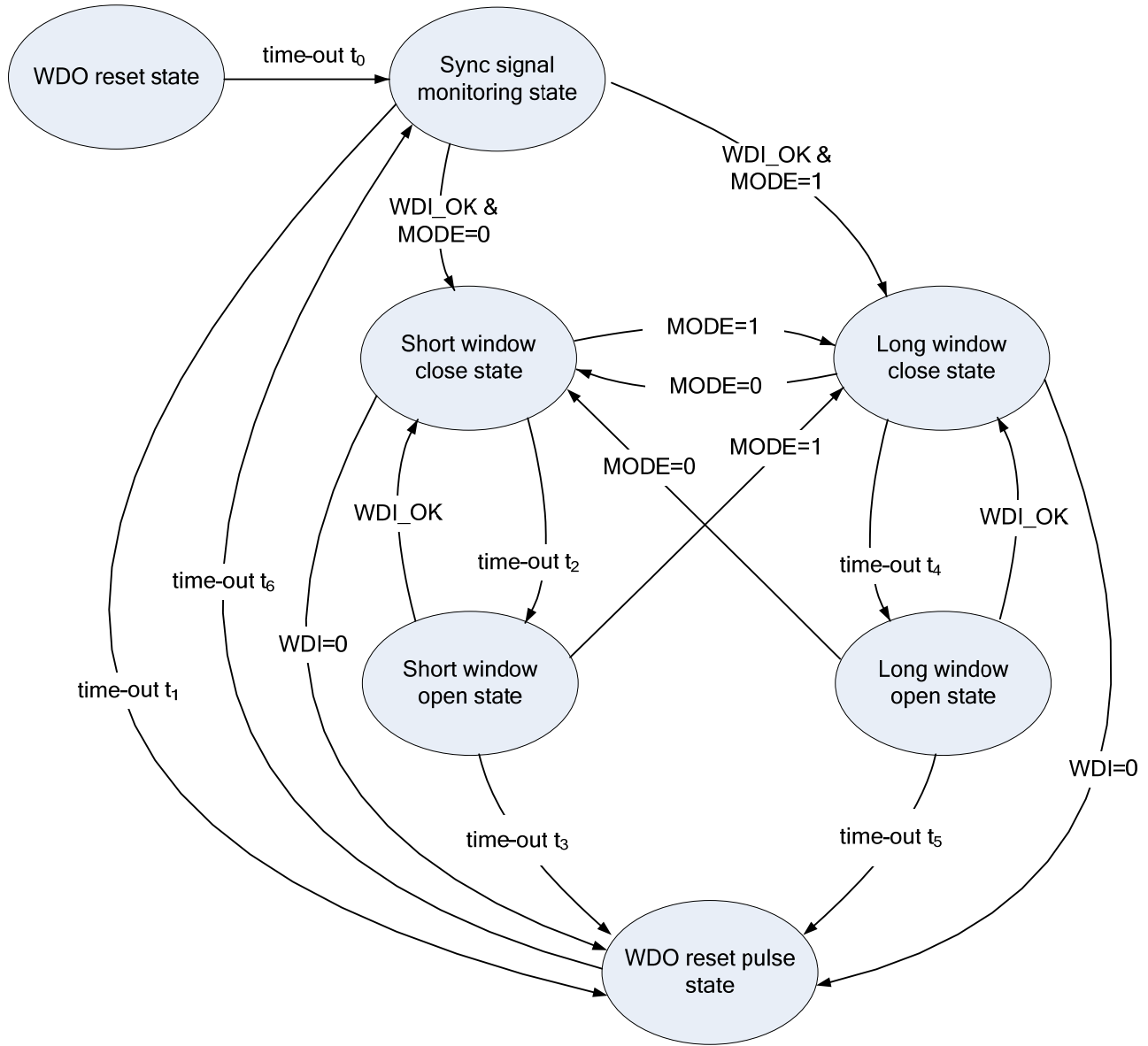
STATE DIAGRAM



NOTE: The state diagram above does not show a WDI error situation.

APPLICATION INFORMATION

Selecting the Inductor

I_{peak} is fixed, and the inductor value can be determined with Equation (3):

$$L = \frac{V_{OUT} \times (V_{IN} - V_{OUT})}{V_{IN} \times I_{peak} \times f_s} \quad (3)$$

Where f_s is the switching frequency at the maximum output current.

A larger inductor value results in a lower switching frequency and higher efficiency. However, the larger value inductor has a larger physical size, a higher series resistance, a lower saturation current, and slow load transient dynamic performance. The inductor value has a lower limit, which is determined by the minimum on time. To keep the inductor functioning properly, the inductor value should be higher than L_{MIN} and can be derived from Equation (4):

$$L_{MIN} = \frac{V_{IN(MAX)} \times t_{ON(MIN)}}{I_{peak}} \quad (4)$$

Where $V_{IN(MAX)}$ is the maximum value of the input voltage, and $t_{ON(MIN)}$ is the 115ns minimum switch-on time.

Switching Frequency

The switching frequency can be estimated with Equation (5):

$$f_s = \frac{2 \times I_o \times V_{OUT} \times (V_{IN} - V_{OUT})}{I_{peak}^2 \times V_{IN} \times L} \quad (5)$$

A larger inductor can achieve a lower f_s . f_s increases as I_o increases. When I_o increases to its maximum value ($I_{peak}/2$), f_s reaches its highest value. The maximum f_s value can be estimated with Equation (6):

$$f_{s(max)} = \frac{V_{OUT} \times (V_{IN} - V_{OUT})}{I_{peak} \times V_{IN} \times L} \quad (6)$$

Setting the Output Voltage

The output voltage is set using a resistive voltage divider from the output voltage to FB. To achieve the desired output voltage, select the resistor divider with Equation (7):

$$\frac{R1}{R2} = \frac{V_{OUT}}{V_{REF}} - 1 \quad (7)$$

Where V_{REF} is the FB reference voltage (1V).

The current flowing into the resistor divider increases the supply current, especially at no-load and light-load conditions. The V_{IN} supply current caused by the feedback resistors can be calculated with Equation (8):

$$I_{IN_FB} = \frac{V_{OUT}}{R1 + R2} \times \frac{V_{OUT}}{V_{IN}} \times \frac{1}{\eta} \quad (8)$$

Where η is the efficiency of the regulator.

To reduce this current, it is recommended to use resistors in the M Ω range. The recommended values of the feedback resistors are shown in Table 1.

Table 1: Resistor Selection for Common Output Voltages

V _{OUT} (V)	R1 (k Ω)	R2 (k Ω)
3.3	1200	523
5	1200	300

Under-Voltage Lockout (UVLO) Point Setting

The MP2420 has an internal, fixed, under-voltage lockout (UVLO) threshold. The rising threshold is about 4.2V while its trailing threshold is about 3.75V. External resistor dividers placed between EN and VIN can be used to achieve a higher equivalent UVLO threshold (see Figure 3).

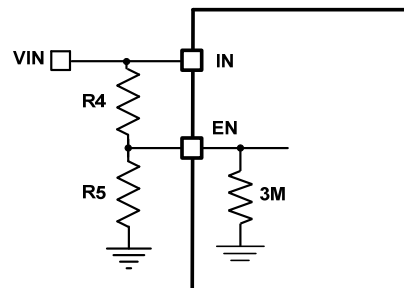

Figure 3: Adjustable UVLO Using EN

The UVLO threshold can be calculated with Equation (9) and Equation (10):

$$\text{UVLO}_{\text{TH_Rising}} = \left(1 + \frac{R4}{3M//R5}\right) \times \text{EN}_{\text{TH_Rising}} \quad (9)$$

$$\text{UVLO}_{\text{TH_Falling}} = \left(1 + \frac{R4}{3M//R5}\right) \times \text{EN}_{\text{TH_Falling}} \quad (10)$$

Soft-Start Capacitor

The soft-start time is the duration of an internal 5 μ A current source charging the SS capacitor from 0 to the FB reference voltage (1V). The SS capacitor can be determined with Equation (11):

$$C_{\text{SS}} = 5 \times t_{\text{SS}} (\mu\text{F}) \quad (11)$$

Feed-Forward Capacitor

The HS-FET turns on when FB drops below the reference voltage, producing ideal load transient performance. However, this also causes the HS-FET to be very sensitive to the FB voltage during turn-on. The HS-FET is affected easily at turn-on, which can trigger a Fsw jitter. Fsw jitter occurs most often when the Vo ripple is very small. To improve jitter performance, it is recommended to use a small feed-forward capacitor of about 39pF between Vo and FB.

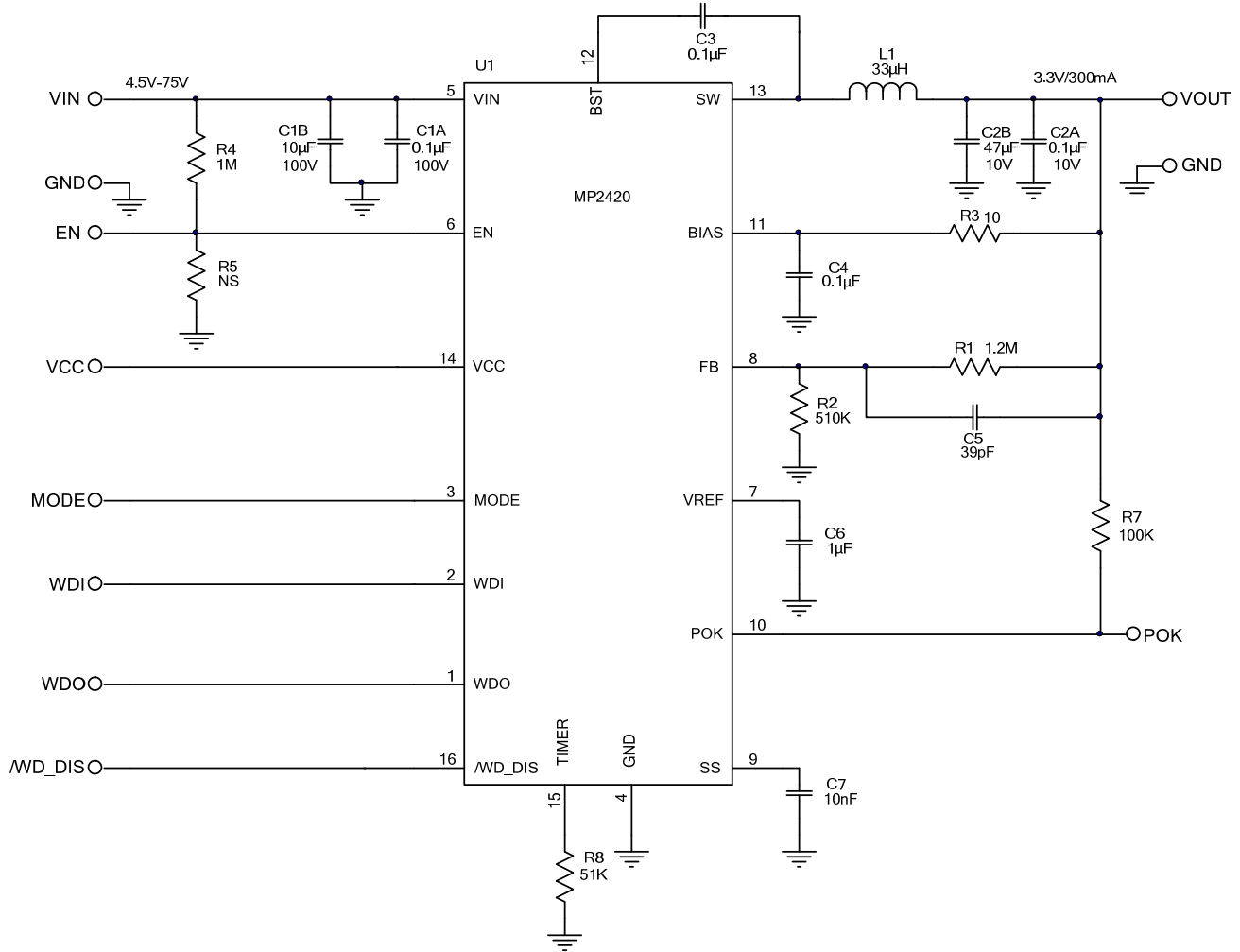
TYPICAL APPLICATION CIRCUITS

Figure 4: 3.3V Output Typical Application Circuit

PACKAGE INFORMATION

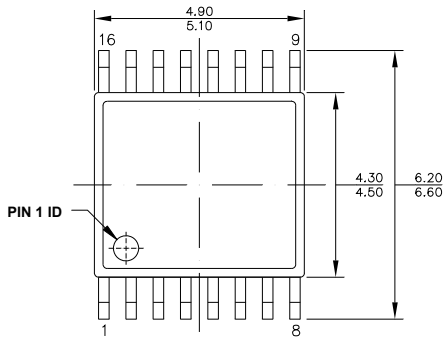
TSSOP-16 EP

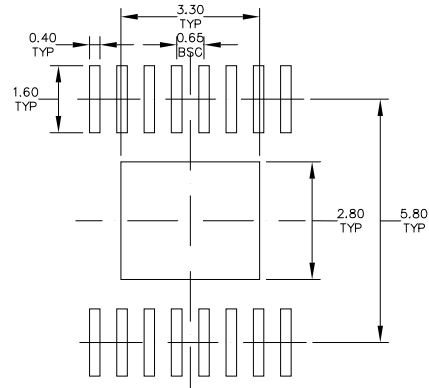

TOP VIEW



RECOMMENDED LAND PATTERN

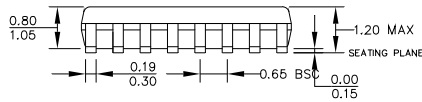

FRONT VIEW

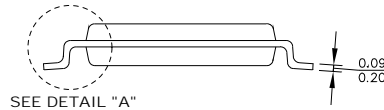

SIDE VIEW

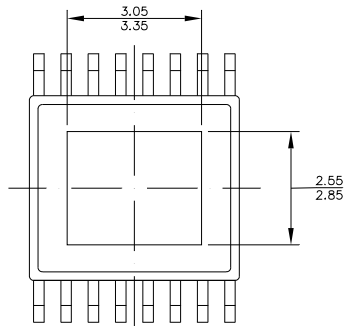

BOTTOM VIEW

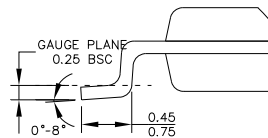

DETAIL "A"

NOTE:

- 1) ALL DIMENSIONS ARE IN MILLIMETERS.
- 2) PACKAGE LENGTH DOES NOT INCLUDE MOLD FLASH, PROTRUSION OR GATE BURR.
- 3) PACKAGE WIDTH DOES NOT INCLUDE INTERLEAD FLASH OR PROTRUSION.
- 4) LEAD COPLANARITY (BOTTOM OF LEADS AFTER FORMING) SHALL BE 0.10 MILLIMETERS MAX.
- 5) DRAWING CONFORMS TO JEDEC MO-153, VARIATION ABT.
- 6) DRAWING IS NOT TO SCALE.

NOTICE: The information in this document is subject to change without notice. Please contact MPS for current specifications. Users should warrant and guarantee that third party Intellectual Property rights are not infringed upon when integrating MPS products into any application. MPS will not assume any legal responsibility for any said applications.