



The Future of Analog IC Technology®

MP2115

2A Synchronous Step-Down Converter with Programmable Input Current Limit

DESCRIPTION

The MP2115 is a high frequency, current mode, PWM step-down converter with integrated input current limit switch. The step-down converter integrates a main switch and a synchronous rectifier for high efficiency without an external Schottky diode. The input average current limit can be externally programmed. It is ideal for powering portable equipment that is powered by an USB port. The MP2115 can supply 2A of load current from a 2.8V to 6V input voltage. The output voltage can be regulated as low as 0.6V.

The MP2115 is available in a space-saving 10-pin QFN package.

FEATURES

- High Efficiency: Up to 92%
- Programmable Switching Frequency from 0.7MHz-2MHz
- Programmable Input Current Limit
- 2A Available Load Current
- 2.8V to 6V Input Voltage Range
- Output Voltage as Low as 0.6V
- Current Mode Control
- Power Good Indicator
- Short Circuit Protection
- Thermal Fault Protection
- <0.1µA Shutdown Current
- Space Saving 3mm x 3mm QFN10 Package

APPLICATIONS

- USB Powered Devices
- Cellular and Smart Phones
- Microprocessors and DSP Core Supplies
- PDAs
- MP3 Players
- Digital Still and Video Cameras
- Portable Instruments

For MPS green status, please visit MPS website under Quality Assurance. "MPS" and "The Future of Analog IC Technology" are Registered Trademarks of Monolithic Power Systems, Inc.

TYPICAL APPLICATION

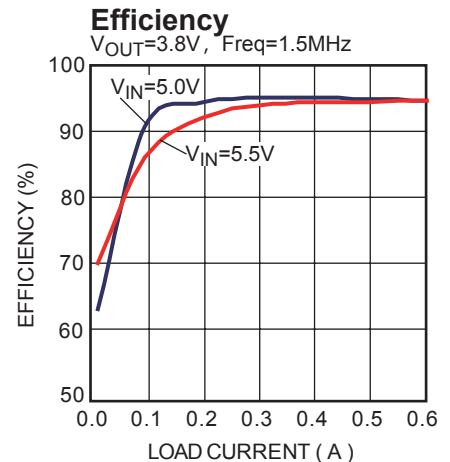
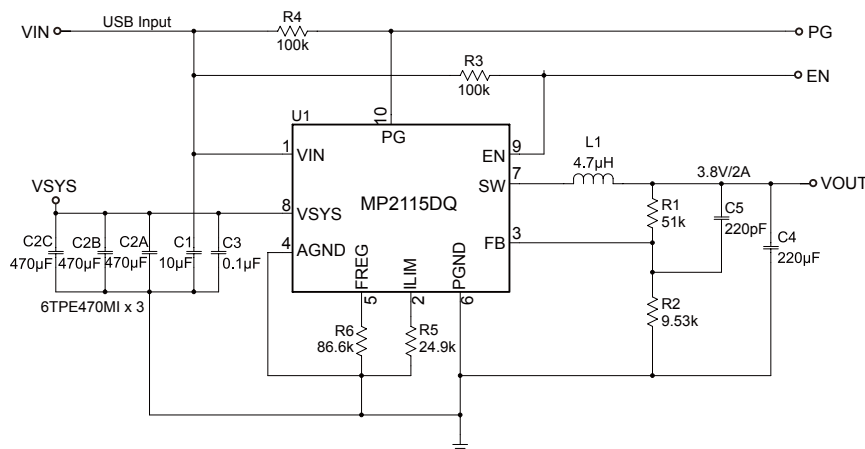

ORDERING INFORMATION

Part Number*	Package	Top Marking	Free Air Temperature (T _A)
MP2115DQ	QFN10 (3mm x 3mm)	2X	-40°C to +85°C

* For Tape & Reel, add suffix -Z (e.g. MP2115DQ-Z).
 For RoHS compliant packaging, add suffix -LF (e.g. MP2115DQ-LF-Z)

PACKAGE REFERENCE

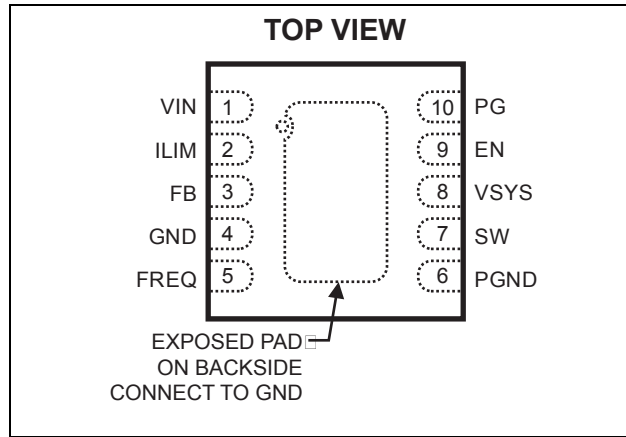

ABSOLUTE MAXIMUM RATINGS ⁽¹⁾

V _{IN} to GND	-0.3V to +6.5V
V _{SW} to GND	-0.3V to V _{IN} +0.3V
V _{FB} , V _{EN} , PG, V _{SYS} , ILIM to GND	-0.3V to +6.5V
Continuous Power Dissipation (T _A = +25°C) ⁽²⁾	2.5W
Junction Temperature	+150°C
Lead Temperature	+260°C
Storage Temperature	-65°C to +150°C

Recommended Operating Conditions ⁽³⁾

Supply Voltage V _{IN}	2.8V to 6V
Output Voltage V _{OUT}	0.6V to 6V
Maximum Junction Temp. (T _J)	+125°C

Thermal Resistance ⁽⁴⁾	θ _{JA}	θ _{JC}
QFN10 (3x3)	50	12... °C/W

Notes:

- Exceeding these ratings may damage the device.
- The maximum allowable power dissipation is a function of the maximum junction temperature T_J (MAX), the junction-to-ambient thermal resistance θ_{JA}, and the ambient temperature T_A. The maximum allowable continuous power dissipation at any ambient temperature is calculated by P_D (MAX) = (T_J (MAX) - T_A) / θ_{JA}. Exceeding the maximum allowable power dissipation will cause excessive die temperature, and the regulator will go into thermal shutdown. Internal thermal shutdown circuitry protects the device from permanent damage.
- The device is not guaranteed to function outside of its operating conditions.
- Measured on JESD51-7, 4-layer PCB.

ELECTRICAL CHARACTERISTICS ⁽⁵⁾
 $V_{IN} = V_{EN} = 5.0V$, $T_A = +25^{\circ}C$, unless otherwise noted.

Parameter	Symbol	Condition	Min	Typ	Max	Units
Supply Current		$V_{EN} = V_{IN}$, $V_{FB} = 0.65V$		800	1000	μA
Shutdown Current		$V_{EN} = 0V$, $V_{IN} = 6V$		0.10	1	μA
IN Undervoltage Lockout Threshold		Rising Edge	2.2	2.35	2.45	V
IN Undervoltage Lockout Hysteresis				60		mV
Regulated FB Voltage	V_{FB}	$T_A = +25^{\circ}C$	0.595	0.607	0.619	V
		$-40^{\circ}C \leq T_A \leq +85^{\circ}C$	0.589	0.607	0.625	
FB Input Bias Current		$V_{FB} = 0.65V$	-50	0.5	+50	nA
PFET On Resistance		$I_{SW} = 100mA$		0.1		Ω
NFET On Resistance		$I_{SW} = -100mA$		0.1		Ω
Load Switch PFET On Resistance				0.22		Ω
Load Switch Current Set		$R_{ILIM} = 25k\Omega$		500		mA
SW Leakage Current		$V_{EN} = 0V$, $V_{IN} = 6V$, $V_{SW} = 0V$ or $6V$	-1		+1	μA
PFET Current Limit ⁽⁶⁾			3.5			A
Oscillator Frequency	f_{OSC}	$R_{FREQ} = 100k\Omega$	1.05	1.3	1.55	MHz
Thermal Shutdown Trip Threshold				145		$^{\circ}C$
EN Input Low Voltage			0.3	1.32	1.45	V
En Input High Voltage			1.65	1.75	2	V
EN Input Current		$V_{IN} = 0V$ to $6V$	-1		1	μA
Power Good Ramp Up Threshold		$C5 = 220pF$		80		%
Power Good Ramp Down Threshold				70		%
Soft Start Time				100		μs
Power Good Sink Current Capability	V_{PG}	Sink 4mA			0.5	V
Power Good Leakage Current	$I_{PG\ LEAK}$	$V_{PG} = 3.3V$	-50		50	nA

Note:

 5) 100% production test at $+25^{\circ}C$. Specifications over the temperature range are guaranteed by design and characterization.

6) Guaranteed by design

PIN FUNCTIONS

Pin #	Name	Description
1	VIN	Supply Input for the power stage.
2	ILIM	Input Current Limit setting pin. A resistor from this pin to ground sets the input current limit.
3	FB	Feedback Input. Connect FB to the center point of the external resistor divider. The feedback threshold voltage is 0.6V.
4	AGND	Analog Ground.
5	FREQ	Switching Frequency Program Input. Connect a resistor from this pin to ground to set the switching frequency.
6	PGND Exposed Pad	The exposed pad and PGND pin must be connected to the same ground plane.
7	SW	Power Switch Output. Inductor connection to drains of the internal PFET and NFET switches.
8	VSYS	Load switch output and switching regulator input. Usually this pin connects to a large tantalum capacitor as energy reservoir.
9	EN	On/Off Control Input.
10	PG	Power good signal. When FB is less than 80% of 0.6V, PG is low. It is an open-drain output. Use a high value pull-up resistor externally to pull it up to system power supply.

TYPICAL PERFORMANCE CHARACTERISTICS

C1=10 μ F, C2=470 μ Fx3, C4=220 μ F, C5=220pF, L = 4.7 μ H, T_A = +25 $^{\circ}$ C, unless otherwise noted.

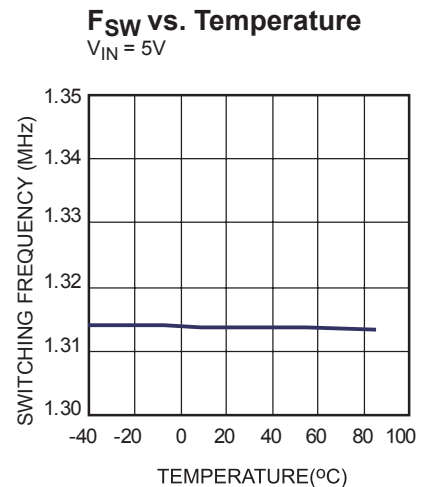
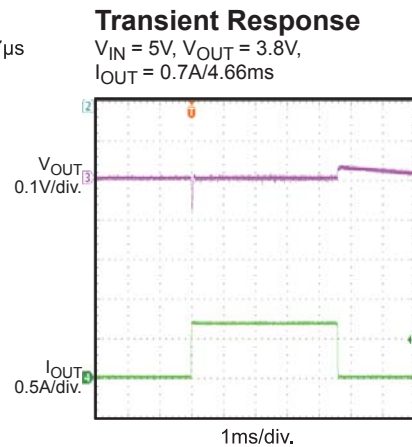
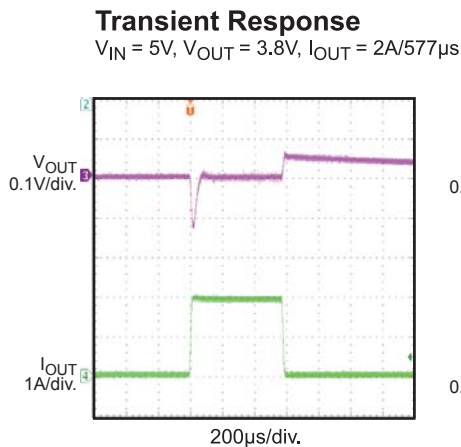
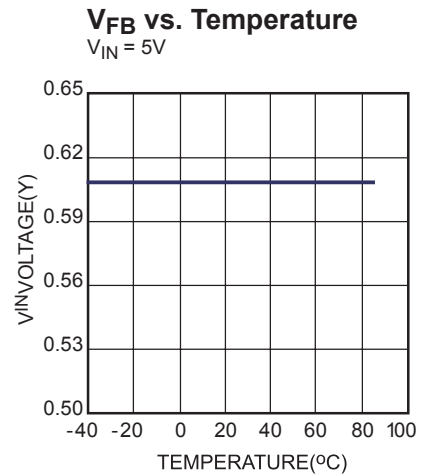
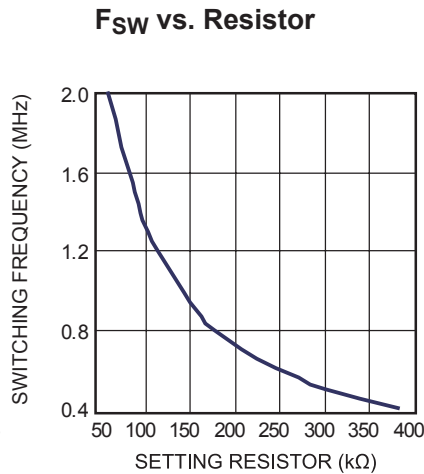
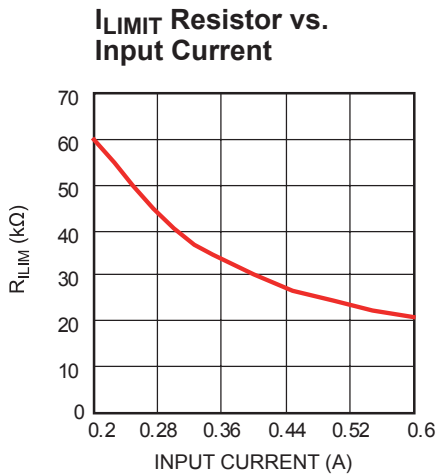
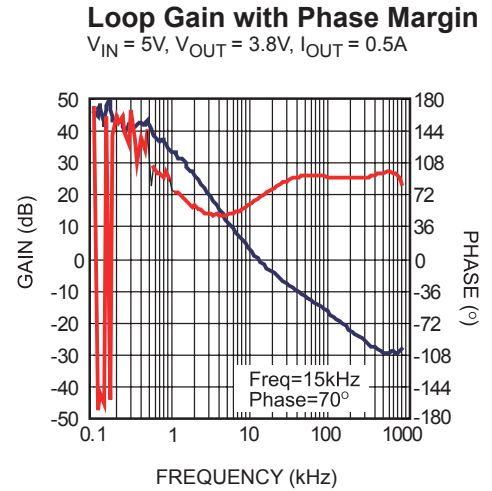
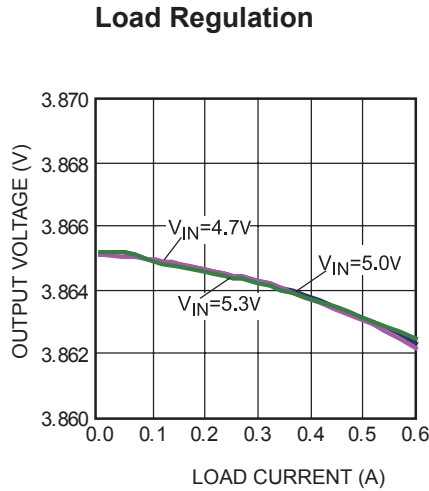
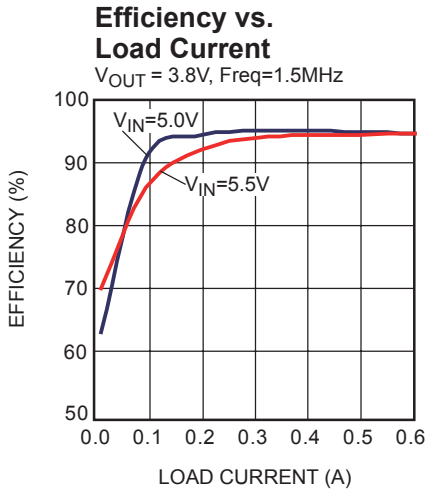

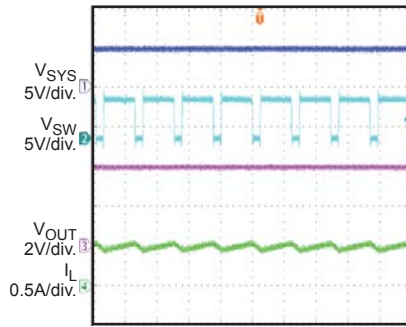
TYPICAL PERFORMANCE CHARACTERISTICS (continued)
C1=10 μ F, C2=470 μ Fx3, C4=220 μ F, C5=220pF, L = 4.7 μ H, T_A = +25°C, unless otherwise noted.
Steady State
 $V_{IN} = 5V, V_{EN}$ put to $V_{IN}, V_{OUT} = 3.8V, I_{OUT} = 0.5A, Freq = 2MHz$

400ns/div.

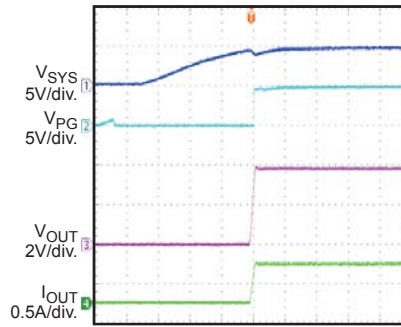
Power Ramp Up
 $V_{IN} = 5V, V_{EN}$ put to $V_{IN}, V_{OUT} = 3.8V, I_{OUT} = 0.5A$

2ms/div.

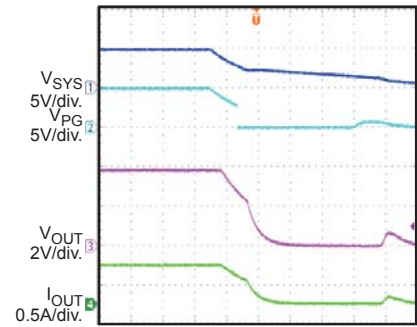
Power Ramp Down
 $V_{IN} = 5V, V_{EN}$ put to $V_{IN}, V_{OUT} = 3.8V, I_{OUT} = 0.5A$

10ms/div.

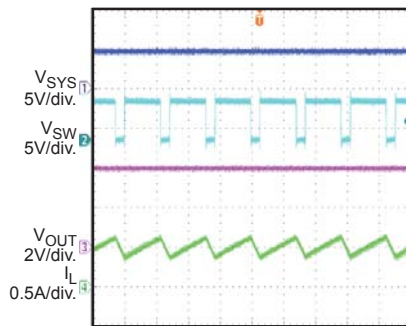
Steady State
 $V_{IN} = 5V, V_{EN}$ put to $V_{IN}, V_{OUT} = 3.8V, I_{OUT} = 0.5A, Freq = 0.7MHz$

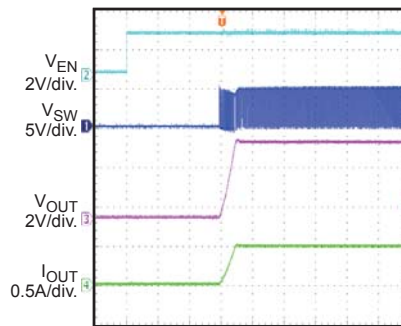
 1 μ s/div.

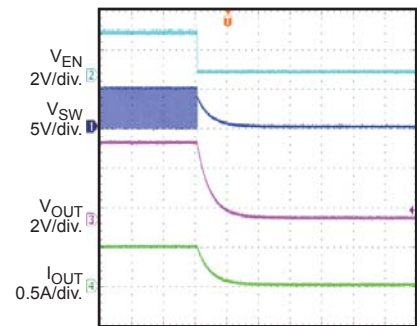
Enable Up
 $V_{IN} = 5V, V_{EN} = 0-2V, V_{OUT} = 3.8V, I_{OUT} = 0.5A, Resistor Load$

 400 μ s/div.

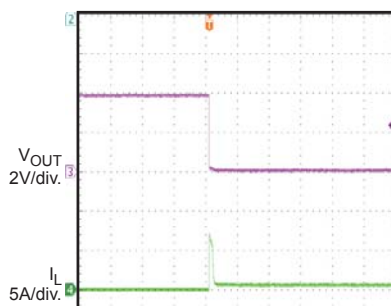
Enable Down
 $V_{IN} = 5V, V_{EN} = 2-0V, V_{OUT} = 3.8V, I_{OUT} = 0.5A, Resistor Load$

4ms/div.

Short Circuit
 $V_{IN} = 5V, V_{EN}$ put to $V_{IN}, V_{OUT} = 3.8V$

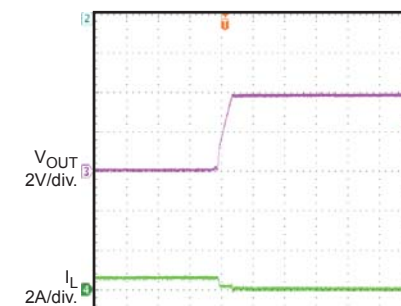
20ms/div.

Short Circuit Recovery
 $V_{IN} = 5V, V_{EN}$ put to $V_{IN}, V_{OUT} = 3.8V$

20ms/div.

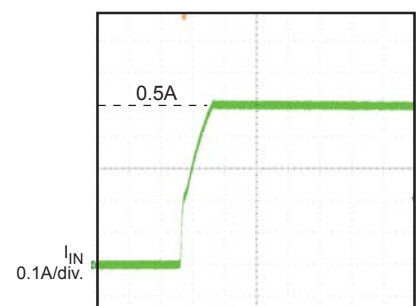
Input Current Limit
 $V_{IN} = 5V, V_{OUT} = 3.8V, R_{SET} = 25k\Omega$

 400 μ s/div.

FUNCTIONAL BLOCK DIAGRAM

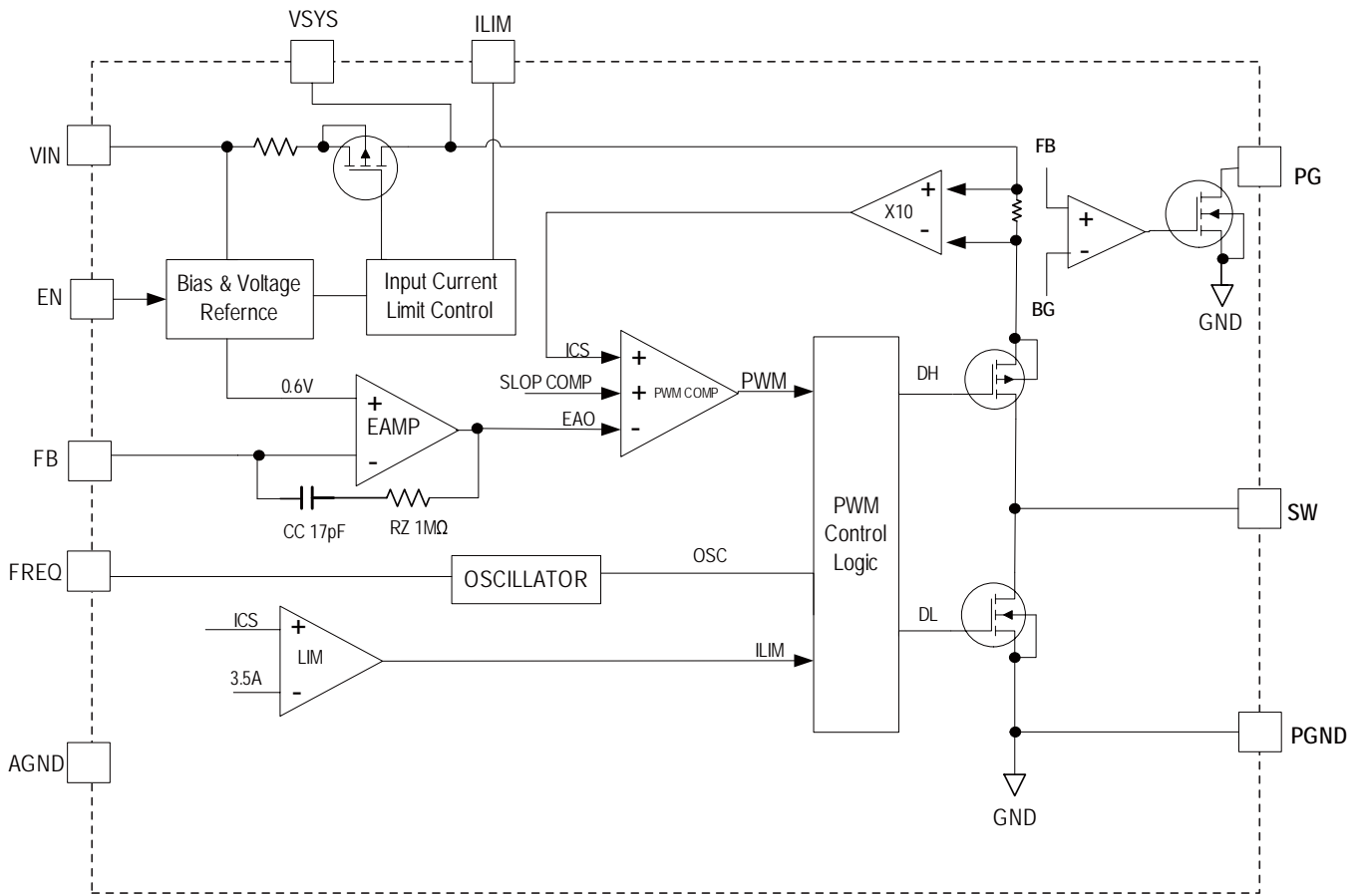

Figure 1—Functional Block Diagram

OPERATION

The MP2115 is a constant frequency current mode PWM step-down converter. The MP2115 is optimized for low voltage, USB port and Li-Ion battery powered applications where high efficiency and small size are critical. The MP2115 uses an external resistor divider to set the output voltage from 0.6V to 6V. The device integrates both a main switch and a synchronous rectifier, which provides high efficiency and eliminates an external Schottky diode. The MP2115 can achieve 100% duty cycle. The duty cycle D of a step-down converter is defined as:

$$D = T_{ON} \times f_{OSC} \times 100\% \approx \frac{V_{OUT}}{V_{IN}} \times 100\%$$

Where T_{ON} is the main switch on time, and f_{OSC} is the oscillator frequency.

Current Mode PWM Control

Slope compensated current mode PWM control provides stable switching and cycle-by-cycle current limit for superior load and line response. This protects the internal main switch and synchronous rectifier. The MP2115 switch is programmable from 0.7MHz to 2MHz. During each cycle the PWM comparator modulates the power transferred to the load by changing the inductor peak current based on the feedback error voltage. During normal operation, the main switch is turned on for a certain time to ramp the inductor current at each rising edge of the internal oscillator, then switched off when the peak inductor current rises above the error voltage. When the main switch is off, the synchronous rectifier will turn on immediately and stay on until the next cycle starts.

Dropout Operation

The MP2115 allows the main switch to remain on for more than one switching cycle and increases the duty cycle when the input voltage drops close to the output voltage. When the duty cycle reaches 100%, the main switch continuously delivers current to the output up to the PFET current limit. The output voltage is the input voltage minus the voltage drop across the main switch and the inductor.

Short Circuit Protection

The MP2115 has short circuit protection. When the output is shorted to ground, the oscillator frequency is reduced to prevent the inductor current from increasing beyond the PFET current limit. The PFET current limit is also reduced to lower the short circuit current. The frequency and current limit will return to the normal values once the short circuit condition is removed and the feedback voltage reaches 0.6V.

Maximum Load Current

The MP2115 can operate down to a 2.8V input voltage; however the maximum load current decreases at lower input due to a large IR drop on the main switch and synchronous rectifier. The slope compensation signal reduces the peak inductor current as a function of the duty cycle to prevent sub-harmonic oscillations at duty cycles greater than 50%. Conversely the current limit increases as the duty cycle decreases.

Programmable Input Current Limit

The MP2115 has an input current limit protection function. It will insure that the input current doesn't exceed the maximum, when the input is supplied by the USB. Once the input current triggers the set current limit level, the output voltage will shut down and latch off until the input is reset.

The input current limit resistor R5 value can be found from Table 1.

Table 1—Resistor Selection vs. Input Current Setting

V_{IN} (V)	V_{OUT} (V)	I_{OUT} (A)	R5 (k Ω)
5	3.8	0.2	47.2
		0.3	33.3
		0.4	25.75
		0.45	23.29
		0.5	24.9

APPLICATION INFORMATION

Output Voltage Setting

The external resistor divider sets the output voltage (see Typical Application Circuit on page 1). The feedback resistor (R1) also sets the feedback loop bandwidth with the internal compensation capacitor (see Figure 1-Function Block Diagram).

Choose R1 around 500kΩ for optimal transient response. R2 is then given by:

$$R2 = \frac{R1}{\frac{V_{OUT}}{0.6V} - 1}$$

Table 2—Resistor Selection vs. Output Voltage Setting

V _{OUT}	R1	R2
1.2V	51kΩ (1%)	51kΩ (1%)
1.5V	51kΩ (1%)	34kΩ (1%)
1.8V	51kΩ (1%)	25.5kΩ (1%)
2.5V	51kΩ (1%)	16kΩ (1%)
3.8V	51kΩ (1%)	9.53kΩ(1%)

Inductor Selection

A 1μH to 10μH inductor with DC current rating at least 25% higher than the maximum load current is recommended for most applications. For best efficiency, the inductor DC resistance shall be <200mΩ. See Table 3 for recommended inductors and manufacturers. For most designs, the inductance value can be derived from the following equation:

$$L1 = \frac{V_{OUT} \times (V_{IN} - V_{OUT})}{V_{IN} \times \Delta I_L \times f_{OSC}}$$

Where Δ_{IL} is the Inductor Ripple Current. Choose inductor ripple current approximately 30% of the maximum load current, 2.5A.

The maximum inductor peak current is:

$$I_{L(MAX)} = I_{LOAD} + \frac{\Delta I_L}{2}$$

Under light load conditions below 100mA, larger inductance is recommended for improved efficiency. Table 4 lists inductors recommended for this purpose.

Table 3—Suggested Surface Mount Inductors

Manufacturer	Part Number	Inductance (μH)	Max DCR (Ω)	Saturation Current (A)	Dimensions LxWxH (mm ³)
Coilcraft	D63CB	4.7	0.026	2	6.3X6.3X3.5
Toko	D53LC	4.7	0.026	2	6.3X6.3X3.5
Sumida	CDC5D23B	4.7	0.062	1.6	6.0X6.0X2.5

Table 4—Inductors for Improved Efficiency at 25mA, 50mA, under 100mA Load.

Manufacturer	Part Number	Inductance (μH)	Max DCR (Ω)	Saturation Current (A)	I _{RMS} (A)
Coilcraft	DO1605T-103MX	10	0.3	1.0	0.9
Murata	LQH4C100K04	10	0.2	1.2	0.8
Sumida	CR32-100	10	0.2	1.0	0.7
Sumida	CR54-100	10	0.1	1.2	1.4

Input Capacitor Selection

The input capacitor (C1) reduces the surge current drawn from the input and switching noise from the device. The input capacitor impedance at the switching frequency must be less than input source impedance to prevent high frequency switching current passing to the input. Ceramic capacitors with X5R or X7R dielectrics are highly recommended because of their low ESR and small temperature coefficients. For most applications, a 10 μ F capacitor is sufficient.

VSYS Capacitor Selection

The VSYS capacitor C2 is used to supply the USB port and with the peak output current, such as during the TDM frame. That output peak current is about 2A. Use three 470 μ F capacitors to avoid large voltage drops.

Output Capacitor Selection

The output capacitor (C4) keeps output voltage ripple small and ensures regulation loop stable. The output capacitor impedance should remain low at the switching frequency. Ceramic capacitors with X5R or X7R dielectrics are recommended. The output ripple ΔV_{OUT} is approximately:

$$\Delta V_{OUT} \leq \frac{V_{OUT} \times (V_{IN} - V_{OUT})}{V_{IN} \times f_{OSC} \times L} \times \left(ESR + \frac{1}{8 \times f_{OSC} \times C2} \right)$$

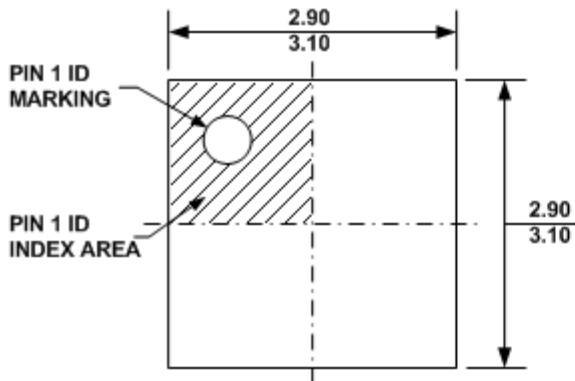
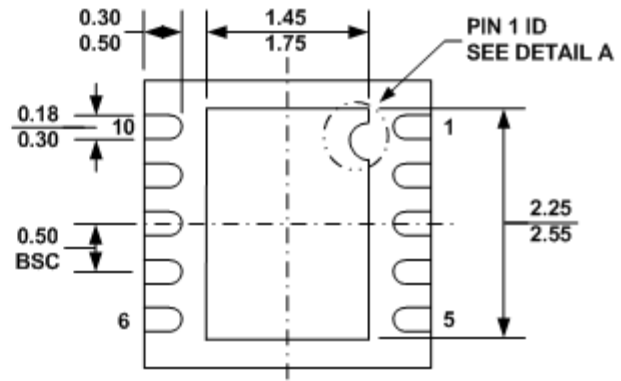
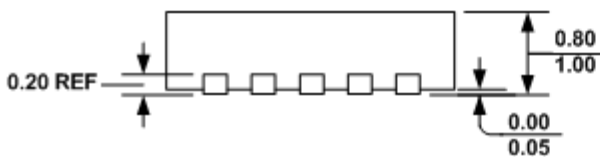
PACKAGE INFORMATION
QFN10 (3mm x 3mm)

TOP VIEW

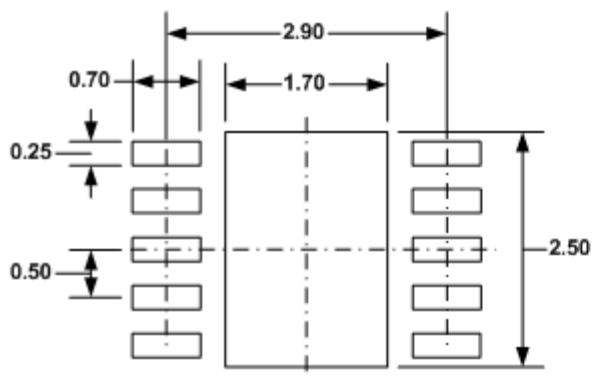
BOTTOM VIEW

SIDE VIEW
**PIN 1 ID OPTION A
R0.20 TYP.**

**PIN 1 ID OPTION B
R0.20 TYP.**

DETAIL A

RECOMMENDED LAND PATTERN
NOTE:

- 1) ALL DIMENSIONS ARE IN MILLIMETERS.
- 2) EXPOSED PADDLE SIZE DOES NOT INCLUDE MOLD FLASH.
- 3) LEAD COPLANARITY SHALL BE 0.10 MILLIMETER MAX.
- 4) DRAWING CONFORMS TO JEDEC MO-229, VARIATION VEED-5.
- 5) DRAWING IS NOT TO SCALE.

NOTICE: The information in this document is subject to change without notice. Please contact MPS for current specifications. Users should warrant and guarantee that third party Intellectual Property rights are not infringed upon when integrating MPS products into any application. MPS will not assume any legal responsibility for any said applications.