



The Future of Analog IC Technology®

EVX2001-Y-00C

90VAC~265VAC/50Hz/60Hz, 12V/5A
Evaluation Board

DESCRIPTION

The EVX2001-Y-00C Evaluation Board is mainly designed to demonstrate the capabilities of MPS highly integrated controller MPX2001. The MPX2001 is an all-in-one flyback controller aims at high-performance and high-integration solution. It combines the primary side driver, secondary side controller and synchronous rectifier (SR) driver in one chip. So the opto-coupler and TL431 can be removed from the secondary side and SR can be turned off on time without any shoot through risk.

The EVX2001-Y-00C is typically designed for a general adapter. Its specification is listed in the below table.

ELECTRICAL SPECIFICATION

Parameter	Symbol	Value	Units
Input Voltage	V_{IN}	90 to 265	VAC
Output Voltage	V_{OUT}	12	V
Output Current	I_{OUT}	5	A
Output Power	P_{OUT}	60	W
Efficiency (4 Point Average)	η	≥ 91	%

The EVX2001-Y-00C has excellent efficiency, which can meet CoC V5 and DoE Level VI requirement easily. It meets IEC61000-4-5 surge immunity and EN55022 conducted EMI requirements. It has multi-protection function, e.g., Brown In/Out, over load protection, over voltage protection, short-circuit protection, cycle by cycle current limit and over-temperature protection, etc.

FEATURES

- 3.5kVrms primary side to secondary side isolation (4.5kVrms isolation voltage for the bare IC)
- 650V integrated HV current source
- 200V integrated SR controller, supporting both DCM and CCM operation
- Precise constant voltage (CV), $\pm 5\%$ CV including transient response
- Extremely low operating current in standby mode
- Frequency modulation and peak current mode control, with slope compensation, line compensation and leading edge blanking
- Adjustable cable drop compensation
- Advanced protections, including primary sensed output Over Voltage Protection (OVP) and Primary Over Current Protection (POCP), real secondary sensed output Over Load Protection (OLP), Brown-in/Brown-out (B/O, B/I), Short Circuit Protection (SCP), Current-Sensing Short Protection (SSP), internal Thermal Shut Down (TSD), Under Voltage Locked-Out (UVLO), and External triggered Protection (Ext.P)

EVX2001-Y-00C EVALUATION BOARD



TOP VIEW



BOTTOM VIEW

(L x W x H) 9.34cm x 4.91cm x 2.5cm

Board Number	MPS IC Number
EVX2001-Y-00C	MPX2001

EVALUATION BOARD SCHEMATIC

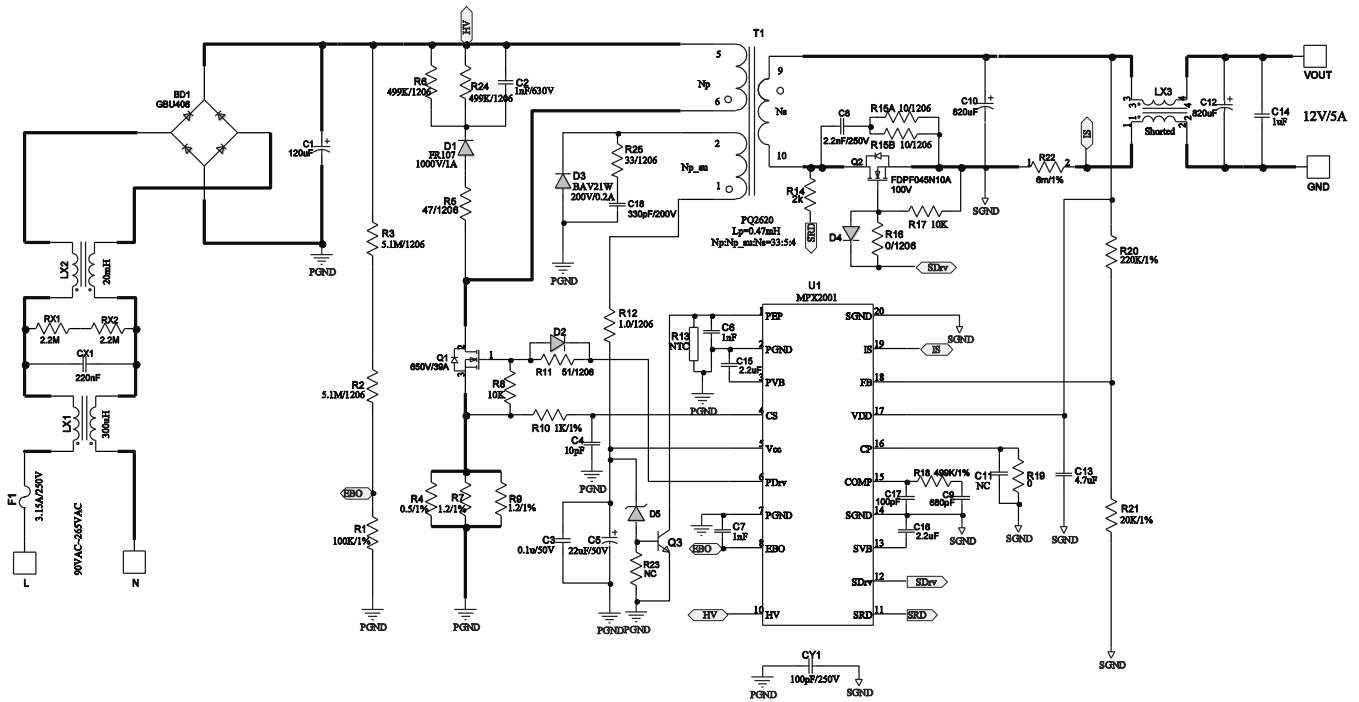

Figure 1—Schematic

PCB LAYOUT (SINGLE-SIDED)

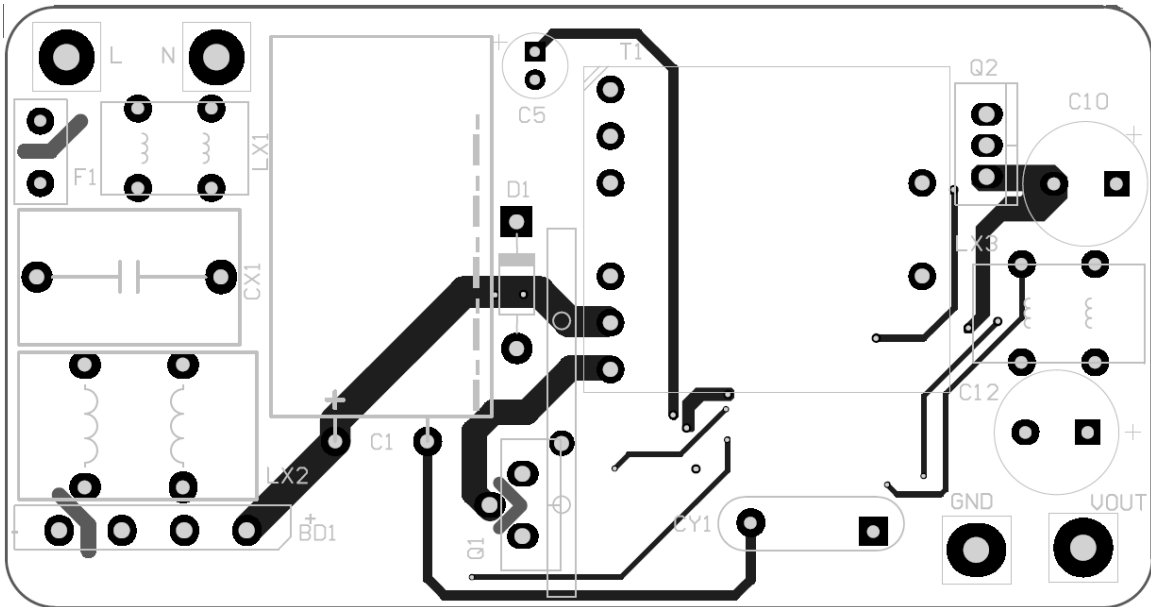

Figure 2—Top Layer

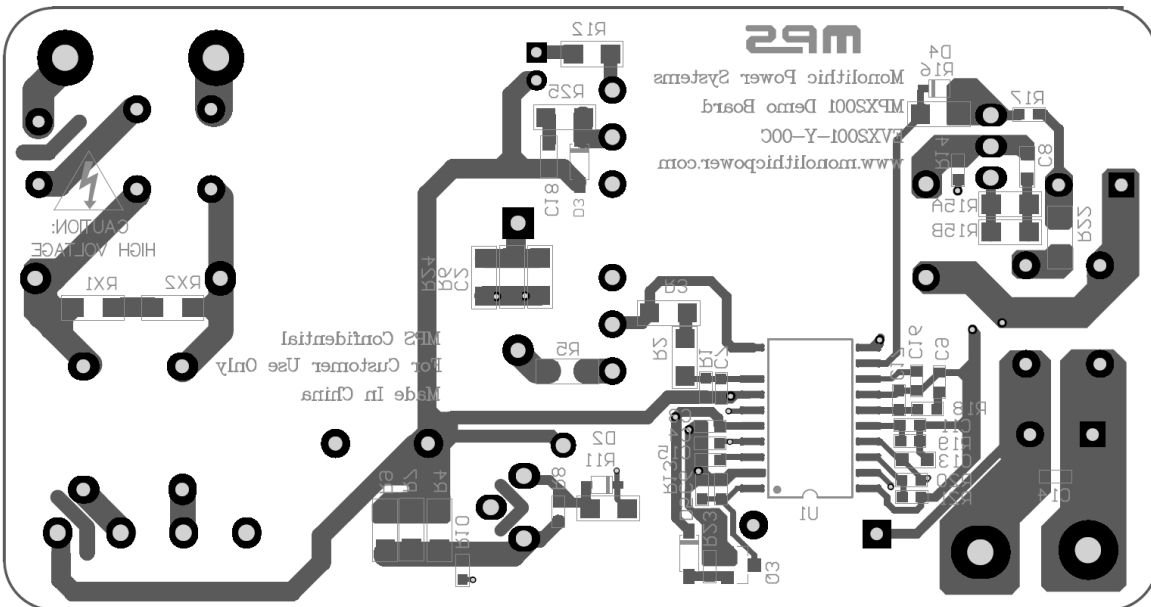

Figure 3—Bottom Layer

CIRCUIT DESCRIPTION

The EVX2001-Y-00C is a single-stage flyback converter with All-in-One controller. The input is universal and output is 12V/5A. The All-in-One controller integrates primary side and secondary side in one chip so the opto-coupler and TL431 can be saved.

F1, LX1, LX2, CX1, BD1, RX1 and RX2 compose the input stage. F1 is the fuse and is used to protect the component failure or some excessive short events. LX1, LX2 and CX1 are configured the EMI filter to suppress conducted EMI. BD1 is the rectifier bridge to convert AC voltage to DC voltage. RX1 and RX2 are the discharging resistors to make CX1 discharging time compliant with safety regulation.

C1 is the filter capacitor. D1, R5, R6, R24 and C2 are configured RCD snubber to suppress voltage spike of Mosfet.

R12, C3, C5 and D3 are used as Vcc power supply. C18 and R25 are configured as the RC snubber for D3.

D5, R23 and Q3 are optional OVP circuit. The OVP threshold can be set by this external circuit.

MPX2001 and its peripheral components are configured flyback controller circuit. MPX2001 integrates the primary side and secondary side controller in one chip so the opto-coupler and TL431 can be saved.

Q1 is the main switch and R4, R7 and R9 are the current sensing resistors.

T1 is the transformer to transfer the power from primary side to secondary side. It is key component for the whole circuit normal working with good performance. So it should be designed carefully.

CY1 is Y capacitor lowering common mode noise to make sure there is enough EMI margin. 100pF capacitance is large enough, which won't introduce much common mode noise between primary side and secondary side.

Q2 is secondary synchronous rectifier (SR) and R15A, R15B and C8 are their snubber to suppress SR high voltage spike.

C10, C12 and C14 are output capacitors. LX3 is the optional common mode inductor for better EMI performance.

R18, C9 and C17 are configured as the compensation network. R20 and R21 are feedback resistors. R22 is the output current sensing resistor for the over current protection.

EVX2001-Y-00C BILL OF MATERIALS

Qty	RefDes	Value	Description	Package	Manufacturer	Manufacturer_P/N
1	BD1	GBU406	Diode;600V;4A	DIP	Diodes	GBU406
1	C1	120µF	Electrolytic Capacitor; 400V;	DIP	Rubycon	KXW Series 18*30
1	C2	1nF/630V	Ceramic Capacitor; 630V;U2J	1206	Murata	GRM31A7U2J102JW31D
1	C3	0.1µF/50V	Ceramic Capacitor; 50V;X7R	0603	Murata	GRM188R71H104KA93D
1	C4	10pF	Ceramic Capacitor; 50V;C0G;	0603	TDK	C1608COG1H100D
1	C5	22µF/50V	Electrolytic Capacitor; 50V;	DIP	Wurth	860160672011
2	C6, C7	1nF	Ceramic Capacitor; 25V;C0G;	0603	muRata	GRM1885C1E102JA01D
1	C8	2.2nF/250V	Ceramic Capacitor; 250V;X7R;	0805	TDK	C2012X7R2E222K
1	C9	680pF	Ceramic 'Capacity; 50V; X7R;	0603	TDK	C1608X7R1H681K
2	C10, C12	820µF	Electrolytic Capacitor; 25V;	DIP	Rubycon	25ZL820
0	C11	NC	No Connected			
1	C13	4.7µF	Ceramic Capacitor; 25V;X7R;	0805	muRata	GRM21BR71E475KA73L
1	C14	1µF	Ceramic Capacitor; 25V;X5R;	0603	TDK	C1608X5R1E105K
2	C15, C16	2.2µF	Ceramic Capacitor; 10V;X7R;	0603	muRata	GRM188R71A225KE15D
1	C17	100pF	Ceramic Capacitor; 50V;C0G	0603	TDK	C1608C0G1H101J
1	C18	330pF	Ceramic Capacitor; 200V;C0G	0805	Murata	GRM21A5C2D331JW01 D
1	CX1	220nF	Capacitor;275V;10%	DIP	Carli	PX224K3ID49L270D9R
1	CY1	100pF/250V	Y Capacitor; 250V;20%	DIP	鸿科	JNK09B101KL02N
1	D1	FR107	Diode;1000V;1A	DO-41	Diodes	FR107
1	D2	1N4148WS	Diode;75V;0.15A;	SOD- 323	Diodes	1N4148WS-7-F
1	D3	BAV21W	Diode;200V;0.2A;	SOD- 123	Diodes	BAV21W-7-F
0	D4,D5	NC	No Connected			
1	F1	SS-5-3.15A	Fuse;250V;3.15A	DIP	COOPER Bussman	SS-5-3.15A
1	LX1	300µH	Common Choke; 300µH;1A	DIP	Emei	TP4U300-00
1	LX2	20mH	Common Choke; 20mH;2A	DIP	Emei	TP4M20-02
1	LX3		Short with wire			
1	Q1	IPP65R280E6	Mosfet;700V; 0.28/10V;	TO220	Infineon	IPP65R280E6
1	Q2	FDPF045N10 A	N-Channel Mosfet; 100V/67A	TO-220	Fairchild	FDPF045N10A
0	Q3	NC	No Connected			

EVX2001-Y-00C BILL OF MATERIALS (continued)

Qty	RefDes	Value	Description	Package	Manufacturer	Manufacturer_P/N
1	R1	100K/1%	Film Resistor;1%;	0603	Yageo	RC0603FR-07100KL
2	R2, R3	5.1M/1206	Film Resistor;1%;	1206	Yageo	RC1206FR-075M1L
1	R4	0.5/1206/1%	Film Resistor; 1%;1/4W;	1206	Housheng	30921540001
1	R5	47/1206	Film Resistor;1%	1206	Yageo	RC1206FR-0747RL
2	R6, R24	499K/1206	Film Resistor;1%;	1206	Yageo	RC1206FR-07499KL
2	R7, R9	1.2/1206/1%	Film Resistor; 1%;1/4W;	1206	Yageo	RC1206FR-071R2L
2	R8, R17	10K	Film Resistor;1%;	0603	Yageo	RC0603FR-0710KL
1	R10	1K	Resistor;1%;1/16W;	0603	Ralec	RF0603-1K
1	R11	51/1206	Film Resistor;1%	1206	Yageo	RC1206FR-0751RL
1	R12	1/1206/1%	Film Resistor; 1%;1/4W;	1206	Yageo	RC1206FR-071RL
0	R13,R23	NC	No Connected			
1	R14	2K	Resistor;1%;1/16W;	0603	Yageo	RC0603FR-072KL
2	R15A,R15B	10/1206	Film Resistor;5%	1206	Yageo	RC1206JR-0710R
1	R16	0/1206	Film Resistor;5%	1206	Yageo	RC1206JR-0720R
1	R18	499K/1%	Film Resistor;1%;	0603	Yageo	RC0603FR-07499KL
1	R19	0	Film Resistor;1%;	0603	Yageo	RC0603FR-070RL
1	R20	220K/1%	Film Resistor;1%;	0603	Yageo	RC0603FR-07220KL
1	R21	20K/1%	Film Resistor; 1%;1/10W;	0603	Yageo	RC0603FR-0720KL
1	R22	6m/1206/1%	Film Resistor; 1%;1/4W;	1206	TA-I Technology	RLM12FTCMR006
1	R25	33/1206/1%	Film Resistor; 1%;1/4W;	1206	Yageo	RC1206FR-0733RL
2	RX1,RX2	2.2M/5%	Film Resistor; 5%;1/4W;	1206	Yageo	RC1206JR-072M2L
1	T1	0.47mH	PQ2625, Lm=0.47mH,	PQ2620	Emei	FX0488
1	U1	MPX2001GY	All-in-one Controller		MPS	All In One
4	L,N, VOUT,GND		2.0mm 铜柱			
0	HS1	NC	Thermal Radiator			

TRANSFORMER SPECIFICATION

Electrical Diagram

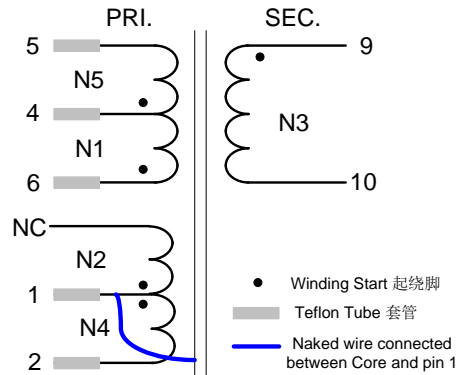

Figure 4—Transformer Electrical Diagram

Notes:

1. Core is connected to Pin 1 with naked wire.

Winding Order

Tape Layer	Winding #	Start-End	Wire Dia	Turns	Winding	Tube
0	N1	6 → 4	0.32mm*2	22		Fit with wire
1	N2	1 → NC	0.32mm*3	7	Spread evenly	Fit with wire
1	N3	9 → 10	0.5mm(T.I.W)*4	4	Spread evenly	Ft with wire
1	N4	1 → 2	0.32mm*4	5	Spread evenly	Fit with wire
3	N5	4 → 5	0.32mm*2	11		Fit with wire

Electrical Specifications

Electrical Strength	60 second, 60Hz, from PRI. to SEC.	3500VAC
	60 second, 60Hz, from PRI. to CORE.	500VAC
	60 second, 60Hz, from SEC. to CORE.	3500VAC
Primary Inductance	Pins 5 - 6, all other windings open, measured at 60kHz, 0.1 VRMS	0.47mH±10%
Primary Leakage Inductance	Pins 5 - 6 with all other pins shorted, measured at 60kHz. 0.1 VRMS	<5μH±10%

Materials

Item	Description
1	Core: PQ2620,
2	Bobbin: PQ2620, 4+2PIN 1 SECT TH, UL94V-0
3	Wire:Φ0.32mm,, 2UEW, Class B
4	Triple Insulation Wire: Φ0.5mm TIW
5	Tape: 8.5mm(W)×0.06mm(TH)
6	Varnish: JOHN C. DOLPH CO, BC-346A or equivalent
7	Solder Bar: CHEN NAN: SN99.5/Cu0.5 or equivalent

EVB TEST RESULTS

Performance Data

Ta=25°C, unless otherwise noted.

Efficiency

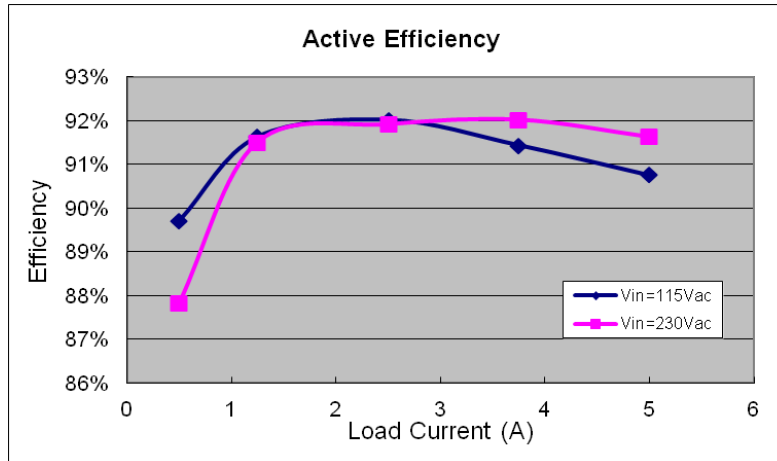

No Load Consumption

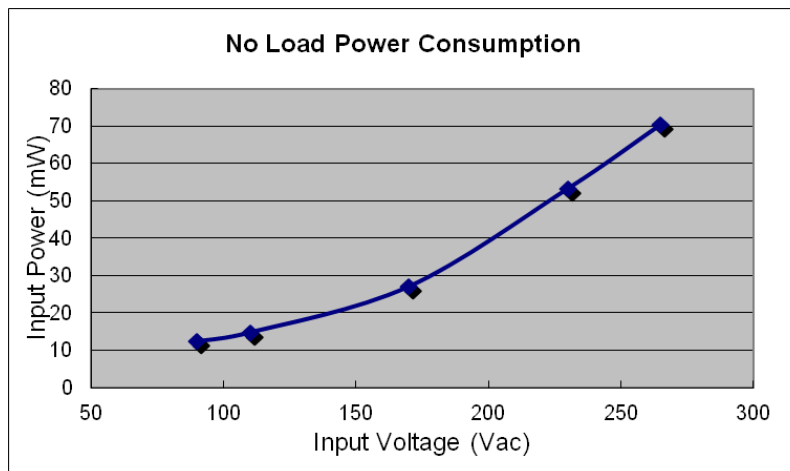

		4 points Average Efficiency	10% Load Efficiency	No Load Consumption
DoE Level VI		0.88	--	0.21
CoC V5	Tier1	0.89	0.79	0.25
	Tier2	0.89	0.79	0.15
Test Data	Vin=115Vac	0.915	0.897	0.016
	Vin=230Vac	0.918	0.878	0.053

Conducted EMI Test

Test with 115Vac/230Vac input and full load condition

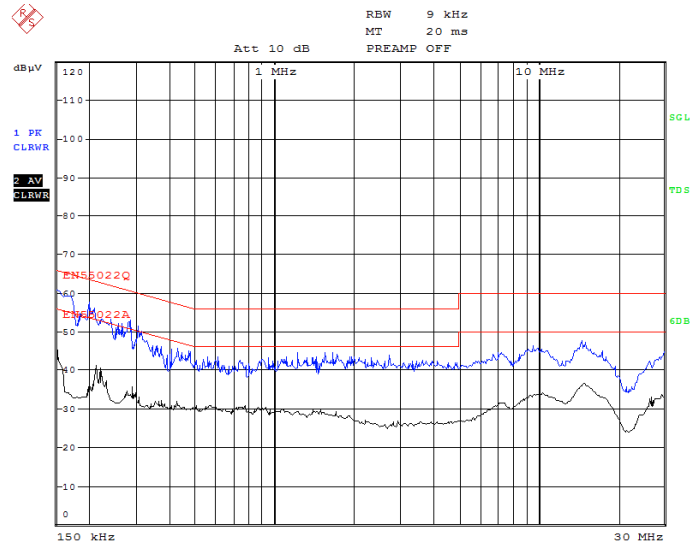

115Vac, 60Hz, Maximum Load, L Line, Output GND floats, EN55022 Limits

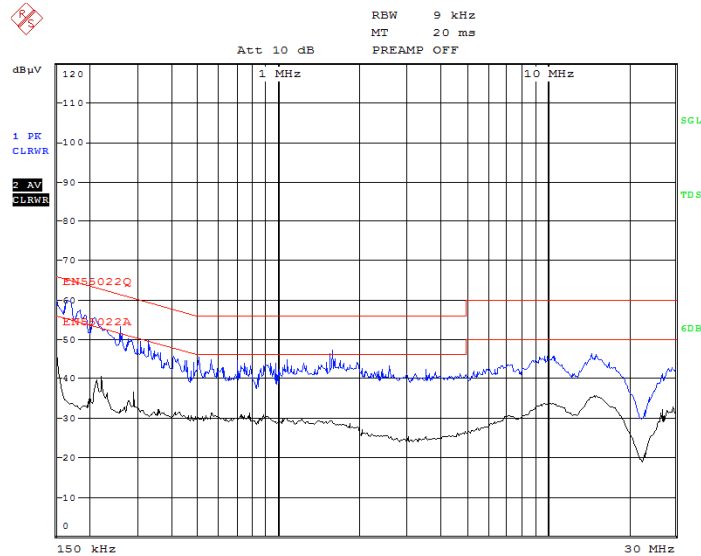

115Vac, 60Hz, Maximum Load, N Line, Output GND floats, EN55022 Limits

Conducted EMI Test (Continued)

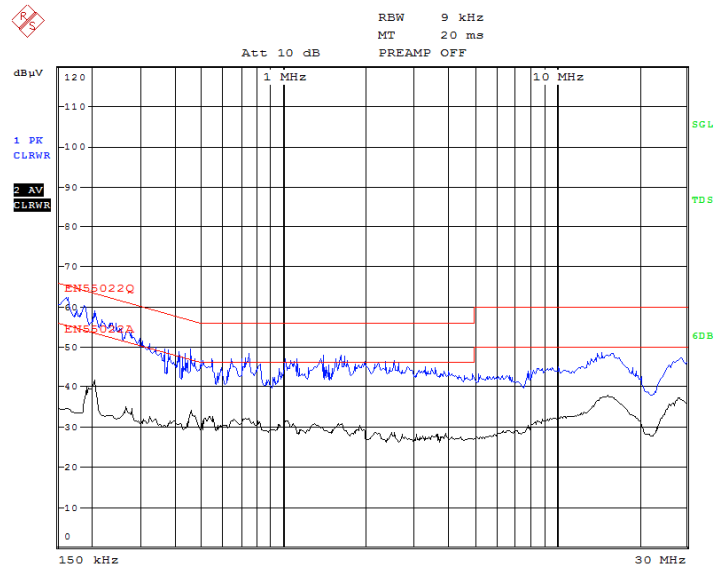

230Vac, 50Hz, Maximum Load, L Line, Output GND floats, EN55022 Limits

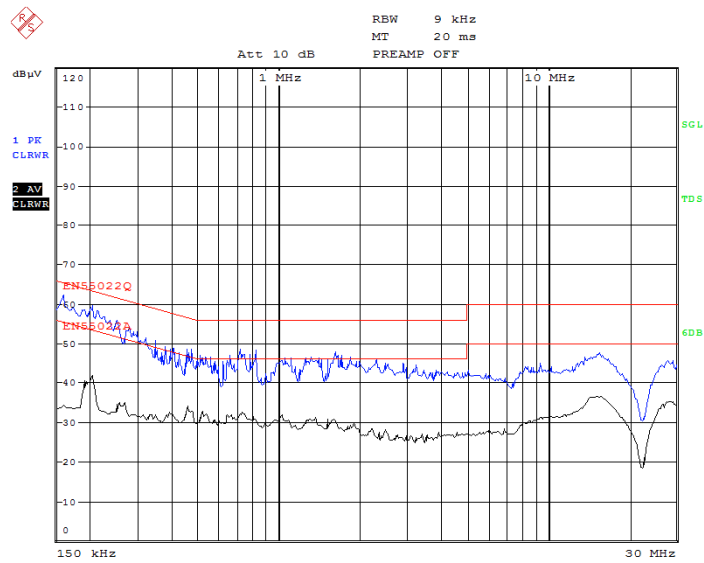

230Vac, 50Hz, Maximum Load, N Line, Output GND floats, EN55022 Limits

Thermal Test

Test with 90Vac/265Vac input and full load condition. PCB layout with 1Oz copper. TA=28°C.



Vin=90Vac



Vin=265Vac

Quick Start Guide

1. Preset Power Supply to $90\text{VAC} \leq V_{\text{IN}} \leq 265\text{VAC}$.
2. Turn Power Supply off.
3. Connect the Line and Neutral terminals of the power supply output to L and N port. For three-wire input application, make OUTPUT GND connected to Earth.
4. Connect Load to:
 - a. Positive (+): VOUT
 - b. Negative (-): GND
5. Turn Power Supply on after making connections.

NOTICE: The information in this document is subject to change without notice. Please contact MPS for current specifications. Users should warrant and guarantee that third party Intellectual Property rights are not infringed upon when integrating MPS products into any application. MPS will not assume any legal responsibility for any said applications.