

DESCRIPTION

The MPQ3425 is a current mode step-up converter with a 3.5A, 90mΩ internal switch to provide a highly efficient regulator with fast response. The MPQ3425 operates at a programmed fix frequency up to 2MHz allowing for easy filtering and low noise. An external compensation pin gives the user flexibility in setting loop dynamics, which allows the use of small, low-ESR ceramic output capacitors. Soft-start results in small inrush current and can be programmed with an external capacitor. The MPQ3425 includes under-voltage lockout, current limiting and thermal overload protection to prevent damage in the event of an output overload. The MPQ3425 is available in a low profile 14-pin QFN package with exposed pad.

ELECTRICAL SPECIFICATIONS

Parameter	Symbol	Value	Units
Input Voltage	V_{IN}	10 – 22	V
Output Voltage	V_{OUT}	48	V
Output Current	I_{OUT}	350	mA

FEATURES

- 3.5A, 90mΩ, 55V Power MOSFET
- Uses Tiny Capacitors and Inductors
- Wide input range: 3V to 22V
- Output Voltage as High as 55V
- Programmable F_{SW} : 300kHz – 2 MHz
- Programmable UVLO, Soft-Start
- Micro power shutdown : $I_q < 1\mu A$
- Thermal Shutdown 150 Deg C
- Available in an 8-Pin SOIC and 14-Pin QFN Package with Exposed Pad

APPLICATIONS

- Audio - Microphone and Tuner Bias
- Telecom – Power Supply
- Automotive – Battery Charger

All MPS parts are lead-free and adhere to the RoHS directive. For MPS green status, please visit MPS website under Products, Quality Assurance page.

"MPS" and "The Future of Analog IC Technology" are registered trademarks of Monolithic Power Systems, Inc.

EVQ3425-L-00A EVALUATION BOARD



LxW (2.5" X 2.5")

Board Number	IC Number
EVQ3425-L-00A	MPQ3425-L

Efficiency

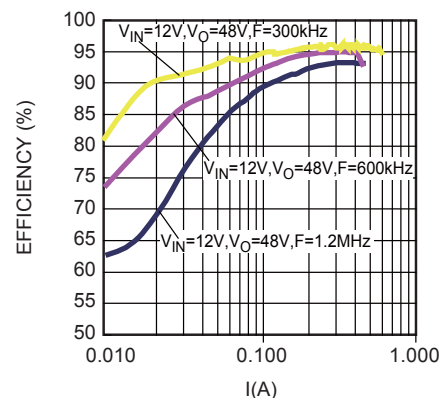

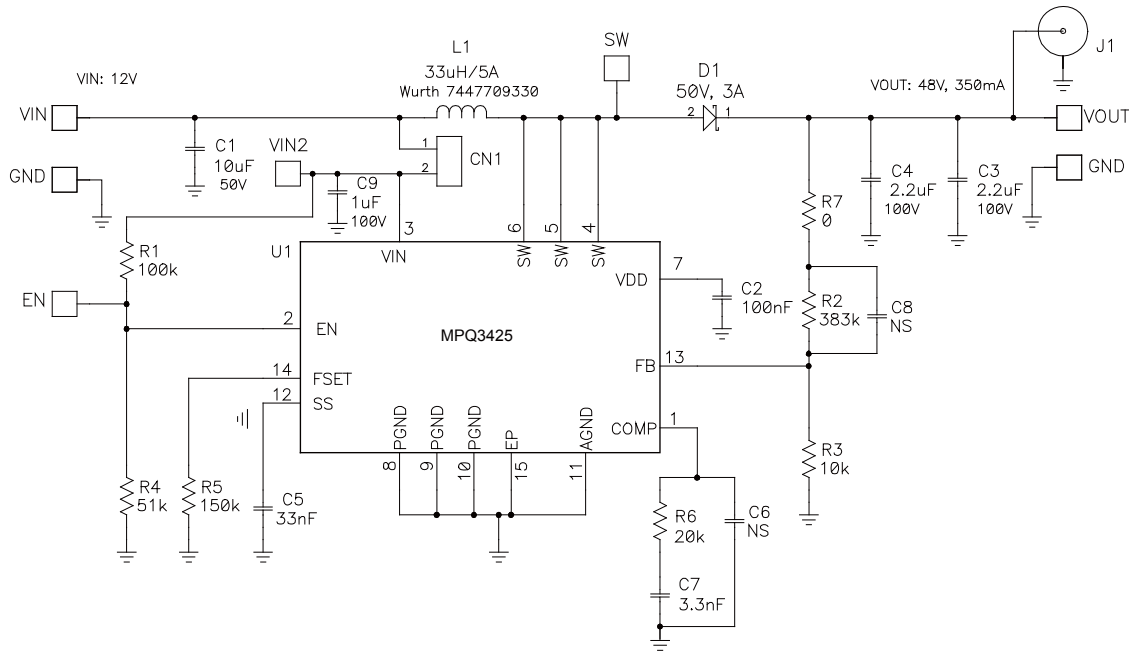
EVALUATION BOARD SCHEMATIC

EVQ3425-L-00A BILL OF MATERIALS

Qty	Ref	Value	Description	Package	Manufacturer	Manufacturer P/N
1	C1	10 μ F	Ceramic Cap., 50V, 10%, X5R	1210	Taiyo Yuden	UMK325BJ106KM-T
1	C2	100nF	Ceramic Cap., 50V, 10%, X7R	0805	muRata	GRM21BR71H104K
2	C3,C4	2.2 μ F	Ceramic Cap., 100V, 10%, X7R	1210	muRata	GRM32ER72A225K
1	C5	33nF	Ceramic Cap., 50V, 10%, X7R	0805	muRata	GRM219R71H333K
0	C6,C8	NS		0805		
1	C7	3.3nF	Ceramic Cap., 50V, 5%, C0G	0805	muRata	GRM2165C1H332J
1	C9	1 μ F	Ceramic Cap., 50V, 10%, X5R	0805	muRata	GRM21BR71H105K
1	CN1		2 Pin Header, 2.54mm	2.54mm	Sullins	PCC02SAAN
1	CN1	SHUNT	Short Jumper, 2.54mm	2.54mm	Sullins	STC02SYAN
1	D1		Diode, 50V, 3A	SMC	Diodes Inc.,	B350-13-F
0	J1	NS				
1	L1	33 μ H/5A	Inductor, I _{dc} 4.2A, R _{dc} 36.8m Ω	12x12mm	Wurth	7447709330
1	R1	100k	Film Res., 5%	0805	Yageo	RC0805JR-07100KL
1	R2	383k	Film Res., 1%	0805	Yageo	RC0805FR-07383KL
1	R3	10.0k	Film Res., 1%	0805	Yageo	RC0805FR-0710KL
1	R4	51k	Film Res., 5%	0805	Yageo	RC0805JR-0751KL
1	R5	150k	Film Res., 5%	0805	Yageo	RC0805JR-07150KL
1	R6	20k	Film Res., 5%	0805	Yageo	RC0805JR-0720KL
1	R7	0 Ω	Film Res., 5%	0805	Yageo	RC0805JR-070RL
1	U1		Boost Converter	QFN14, 3x4mm	MPS	MPQ3425-L-R1

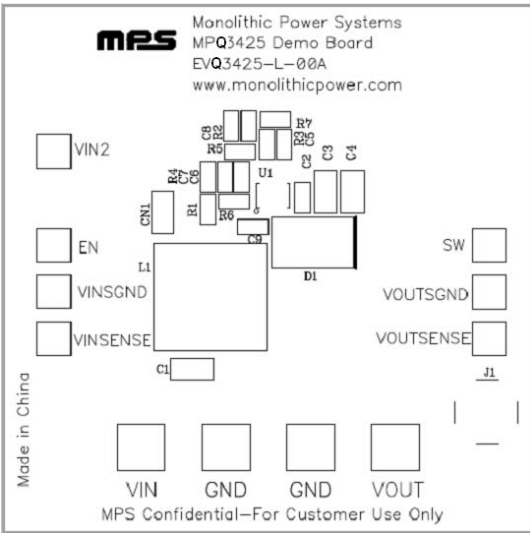
PRINTED CIRCUIT BOARD LAYOUT

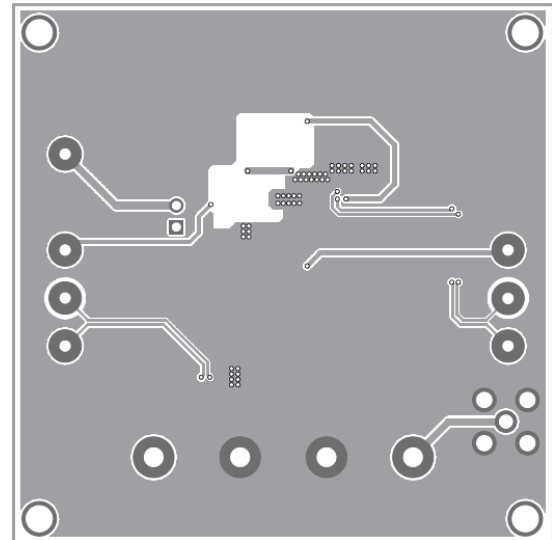

Top Silk Layer



Bottom Layer

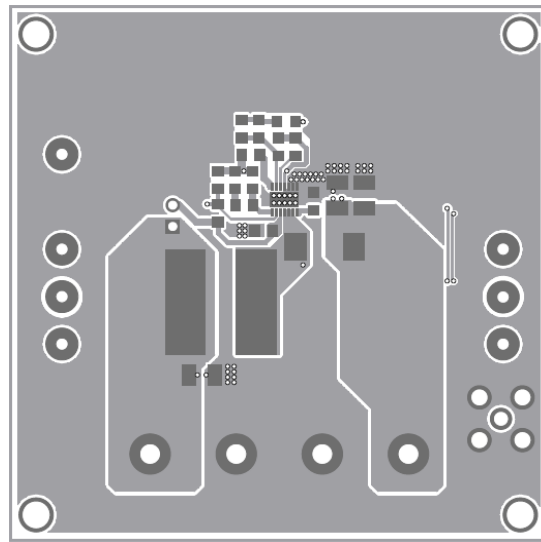

Top Layer

QUICK START GUIDE

The output voltage of this board is set to 48V. The frequency is set to 300kHz. The board layout accommodates most commonly used inductors and output capacitors.

1. Preset the power supply to $4V \leq V_{IN} \leq 22V$.
2. Turn the power supply off.
3. Connect the power supply terminals to:
 - a. Positive (+): VIN
 - b. Negative (-): GND
4. Connect the load to:
 - a. Positive (+): VOUT
 - b. Negative (-): GND
5. Make sure the CN1 jumper is installed
6. Turn the power supply on after making the connections.
7. The MP3425 is enabled on the evaluation board once VIN is applied.
8. The output voltage VOUT can be changed by varying R2. Calculate the new value using the formula:
9. $R2 = \left(\frac{V_{OUT}}{V_{FB}} - 1\right) \times R3$
 - a. Where $V_{FB} = 1.25V$ and $R2 = 10k\Omega$
10. The frequency can be changed by adjusting R5. The formula is:
11. $F_{SET} = 23 \times (R5)^{-0.86}$
 - a. Where FSET is in MHz and R5 is in kΩ

NOTICE: The information in this document is subject to change without notice. Users should warrant and guarantee that third party Intellectual Property rights are not infringed upon when integrating MPS products into any application. MPS will not assume any legal responsibility for any said applications.