

## DESCRIPTION

The EVQ2489DN-00A is an evaluation board for the MPQ2489DN, a step-down converter designed in continuous current mode for driving the high brightness light emitting diodes (LEDs) from wide input voltage 8V-60V.

The MPQ2489 employs hysteretic control architecture to regulate a high accuracy LED current, which is measured through an external high-side current sensing resistor. Moreover, this control scheme provides optimized circuit stabilization and very quick response time without the loop compensation. Its low 200mV average feedback voltage reduces power loss and improves the converter efficiency.

The MPQ2489 implements PWM and Analog dimming with DIM pin. The MPQ2489 includes under-voltage lockout function, thermal overload protection preventing damage in the event of an output overload.

## ELECTRICAL SPECIFICATIONS

Parameter	Symbol	Value	Units
Input Voltage	V <sub>IN</sub>	8 –60	V
Output Voltage	V <sub>OUT</sub>	<V <sub>in</sub> -3V	
LED Current	I <sub>LED</sub>	550	mA

## FEATURES

- Internal 65V MOSFET
- Wide 8V to 60V Input Range
- High Efficiency (Up to 97%)
- Hysteretic Control
- PWM & Analog Dimming
- 1000:1 PWM Dimming Resolution
- UVLO, Thermal Shutdown

## APPLICATIONS

- Low Voltage Halogen Replacement
- Low Voltage General Illumination
- Automotive/Decorative LED Lighting
- Signs/Emergency Lighting
- LED Backlighting

All MPS parts are lead-free and adhere to the RoHS directive. For MPS green status, please visit MPS website under Quality Assurance. "MPS" and "The Future of Analog IC Technology" are Registered Trademarks of Monolithic Power Systems, Inc.

## EVQ2489DN-00A EVALUATION BOARD

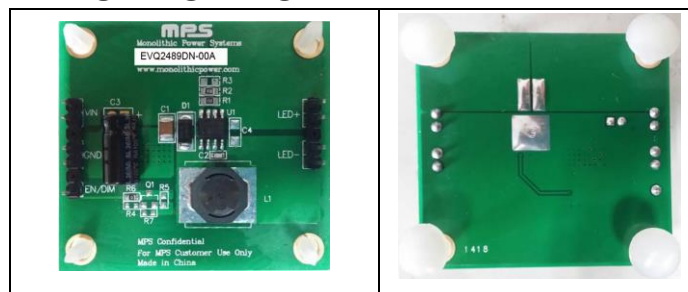

(5x 4.6 x 1) cm x cm x cm

Board Number	MPS IC Number
EVQ2489DN-00A	MPQ2489DN

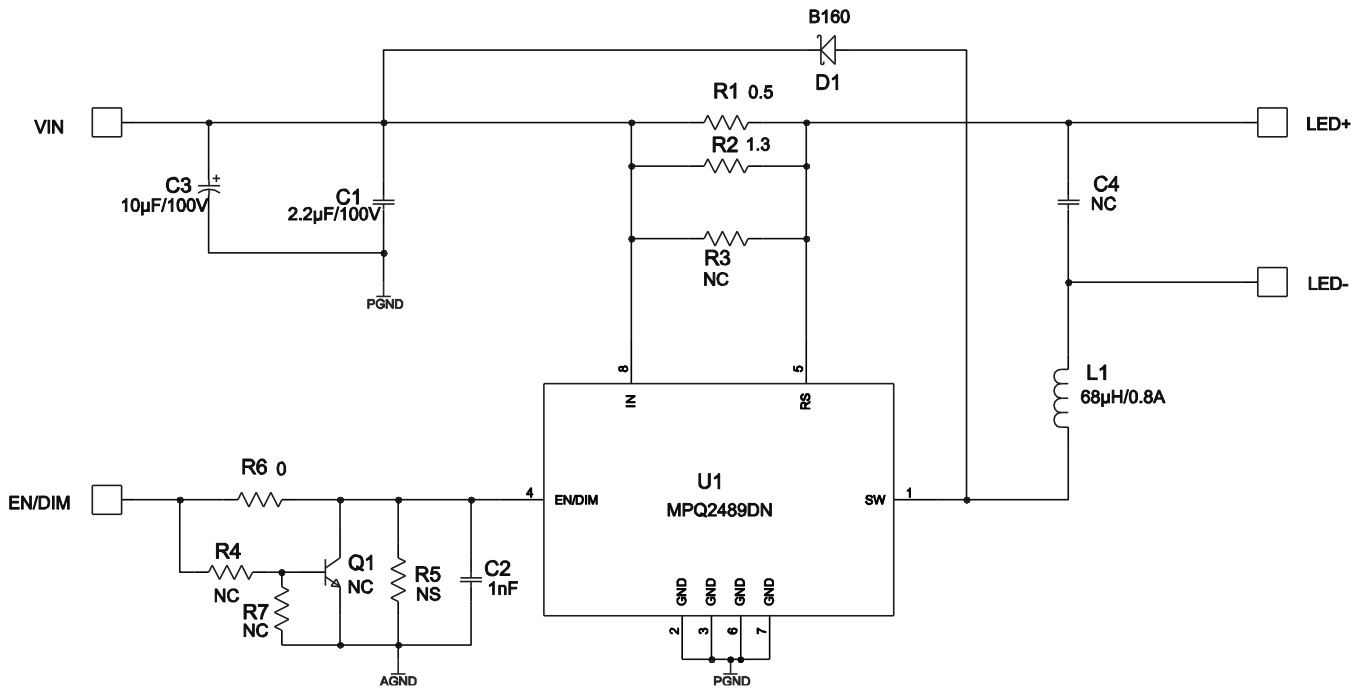
**EVALUATION BOARD SCHEMATIC**

**EVQ2489DN-00A BILL OF MATERIALS**

Qty	Ref	Value	Description	Package	Manufacturer	Part Number
1	C1	2.2µF	Ceramic Capacitor, 100V	1210	muRata	GRM32ER72A225KA35L
1	C2	1nF	Ceramic Capacitor, 25V	603	muRata	GRM1885C1E102JA01D
1	C3	10µF	Electrolytic Capacitor, 100V	DIP		10µF./100V
1	C4	NC				
5	D1	B160	Diode Schottky	SMA	Diodes Inc.	B160
1	L1	68µH	Inductor 0.8A	SMD	Würth	744065680
1	R1	0.5Ω	1%	805	Yageo	RC0805FR-07R5L
1	R2	1.3Ω	1%	805	Yageo	RC0805FR-071R3L
1	R3	NC				
1	R4, R5, R7	NC				
1	R6	0 Ω	5%	603	Yageo	RC0603JR-070RL
1	Q1	NC				
1	U1	MPQ2489DN	MPS WLED Driver	SO8	MPS	MPQ2489DN

PRINTED CIRCUIT BOARD LAYOUT

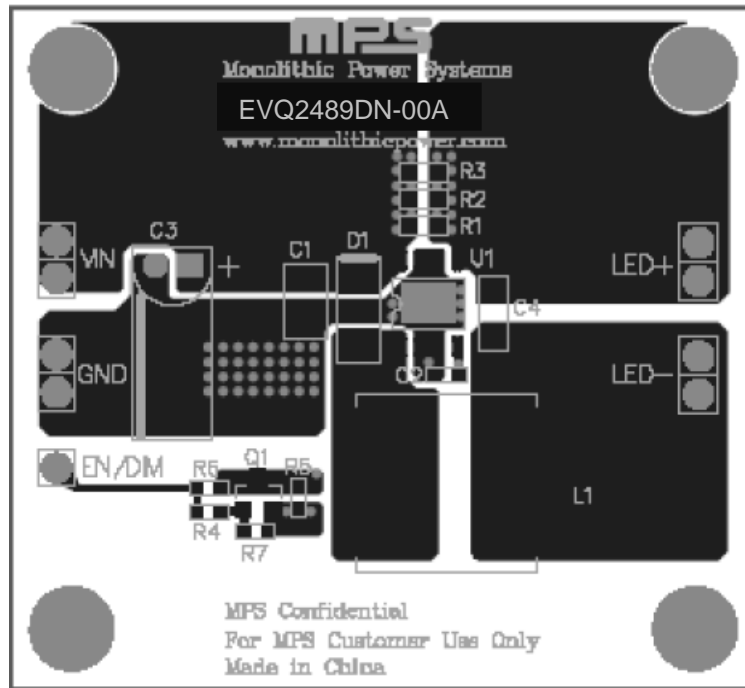

Figure 1—Top Layer

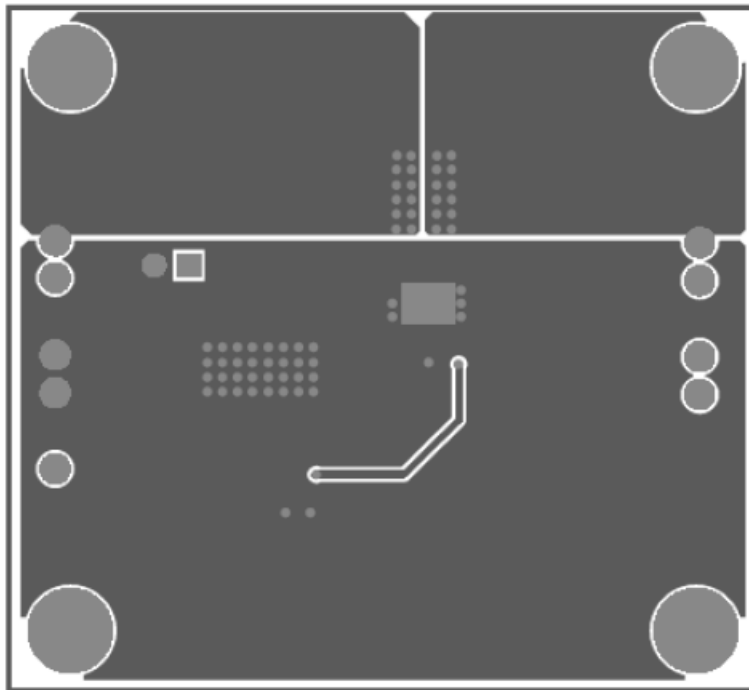

Figure 2—Bottom Layer

## QUICK START GUIDE

1. Connect the positive and negative terminals of the load to the LED+ and LED- pins on the EV board, respectively.
2. Connect the positive and negative terminals of DC power supply to the VIN and GND. Turn the power supply on.
3. If PWM dimming is required, provide a 200Hz to 2kHz PWM signal to EN /DIM pin. Remove R6 and put a 10kΩ resistor on R4 and R7. If analog dimming is required, please open R4 and short R6 then provide 0.3-2.5V voltage directly to the EN/DIM pin.
4. The LED current is adjustable by set current sense resistor R1//R2.as below formula,

$$R1//R2=200mV/I_{LED}$$

**NOTICE:** The information in this document is subject to change without notice. Users should warrant and guarantee that third party Intellectual Property rights are not infringed upon when integrating MPS products into any application. MPS will not assume any legal responsibility for any said applications.