

DESCRIPTION

The NB685A provides a complete power supply for DDR3, DDR3L, LPDDR3, and DDR4 memory with the highest power density. It integrates a high frequency synchronous rectified step-down switch mode converter (VDDQ) with a 1A sink/source LDO (VTT) and buffered low noise reference (VTTREF).

Adaptive Constant-On-Time (COT) control mode provides fast transient response and eases loop stabilization. The DC auto tune loop provides good load and line regulation.

The VTT LDO provides 1A sink/source current capability and requires only 22uF ceramic capacitance. The VTTREF tracks VDDQ/2 with an excellent 1% accuracy.

Full protection features include OC Limit, OVP, UVP and thermal shut down and Over temperature warning (OTW).

The converter requires minimum number of external components and is available in QFN 3x3 packages.

FEATURES

- Wide 4.5V to 26V Operating Input Range
- Compatible for IMVP8
- 100uA low quiescent Current
- 12A Continuous Output Current
- Selectable Ultrasonic Mode
- Selectable 500k/700k Switching Frequency
- Built-in +/- 1A VTT LDO
- 1% Buffered VTTREF Output
- Adaptive COT for Fast transient
- DC Auto Tune Loop
- Stable with POSCAP and Ceramic Output Cap
- Over Temperature Warning
- Internal Soft Start
- Output Discharge
- OCL, OVP, UVP, OTP
- Latch off Reset via EN or Power Cycle

APPLICATIONS

- Laptop Computer
- Networking Systems and Server
- Distributed Power Systems

All MPS parts are lead-free and adhere to the RoHS directive. For MPS green status, please visit MPS website under Products, Quality Assurance page. "MPS" and "The Future of Analog IC Technology" are registered trademarks of Monolithic Power Systems, Inc.

EVNB685A-Q-00A EVALUATION BOARD



(L x W) 85mm x 85mm

Board Number	MPS IC Number
EVNB685A-Q-00A	NB685A

Efficiency vs. Load Current

V_{OUT}=1.35V, F_S=500KHz, L=1.2uH, DCR=2mΩ, C_{out}=3*22uF, R_{MODE}=150k

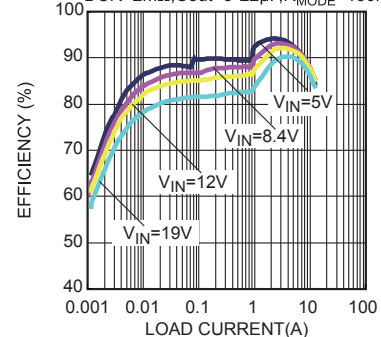

EVALUATION BOARD SCHEMATIC

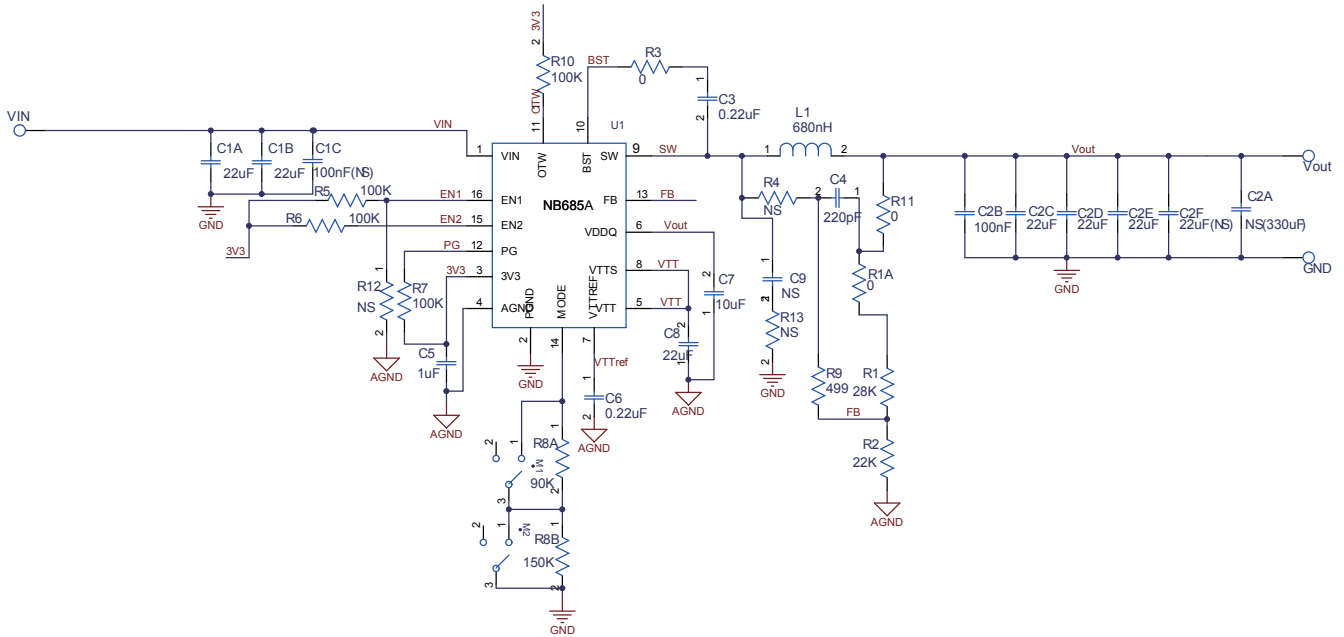

EVNB685A-Q-00A BILL OF MATERIALS

Qty	Ref	Value	Description	Package	Manufacturer	Part Number
2	C1A, C1B	22 μ F	Ceramic Capacitor; 25V;X5R;1206;	1206	muRata	GRM32ER61E226KE15L
1	C2B	100nF	Ceramic Capacitor; 50V;X7R;0603;	0603	muRata	GRM188R71H104KA93D
1	C1D	100nF	Ceramic Capacitor; 50V;X7R;0402;	0402	TDK	C1005X7R1H104K
3	C1C, C2A, C2F	NS				
4	C2C, C2D, C2E, C8	22 μ F	Ceramic Capacitor; 6.3V;X5R	0805	Murata	GRM21BR60J226ME39L
2	C3,C6	220nF	50V; X7R;0402	0402	Taiyo Yuden	UMK105BJ224KV-F
1	C4	220pF	Ceramic Capacitor; 50V;C0G;0603	0603	muRata	GRM1885C1H221JA01D
1	C5	1 μ F	Ceramic Capacitor; 6.3V;X5R;0603	0603	muRata	GRM188R60J105KA01D
1	C7	10 μ F	Ceramic Capacitor, 6.3V;X5R;0805	0805	muRata	GRM21BR70J106KE76L
1	R1	28k	Film Resistor;1%	0603	Yageo	RC0603FR-0728KL
1	R2	22k	Film Resistor;1%	0603	Yageo	RC0603FR-0722KL
3	R1A, R3,R11	0	Film Resistor;1%	0603	Yageo	RC0603FR-070RL
1	R4	NS				
4	R5,R6, R7,R10	100k	Film Resistor;1%	0402	Yageo	RC0402FR-07100KL
1	R8A	90k	Film Resistor;1%	0603	Yageo	RC0603FR-0790KL
1	R8B	150k	Film Resistor;1%	0603	Yageo	RC0603FR-07150KL
1	R9	499	Film Resistor;1%	0603	Yageo	RC0603FR-07499RL
1	L1	0.68 μ H	Inductor;680nH;3.1m; 17A	SMD	Würth	744311068
1	D1	NS				
1	U1	NB685A	NB685A	QFN3*3	MPS	NB685A
2	M1, M2	4503010 14042	Button	DIP	Würth	450301014042

PRINTED CIRCUIT BOARD LAYOUT

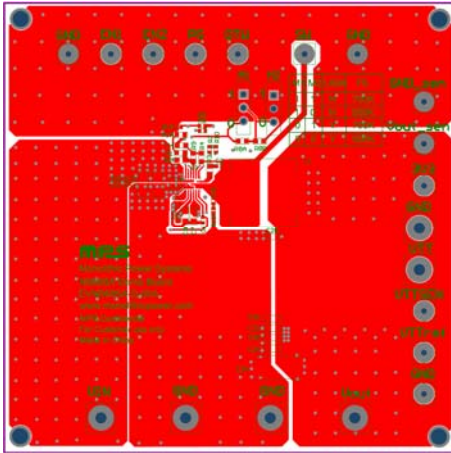

Figure 1—Top Layer

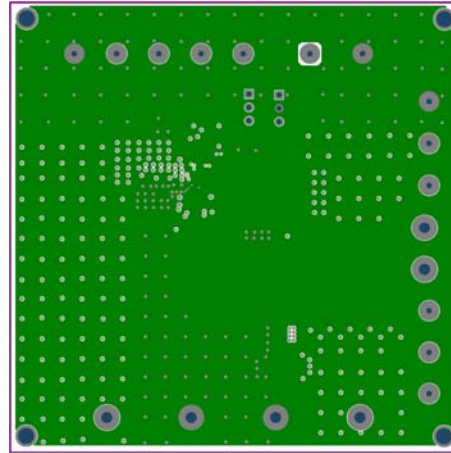

Figure 2—Inner Layer 1

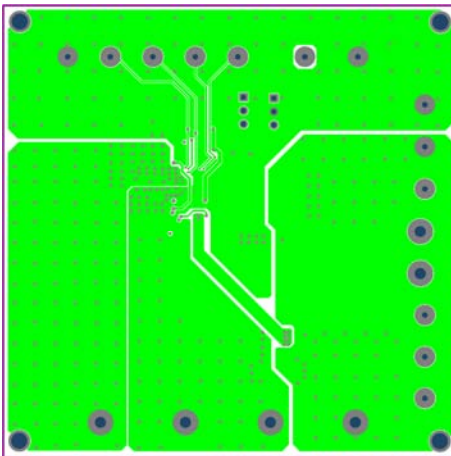

Figure 3—Inner Layer 2

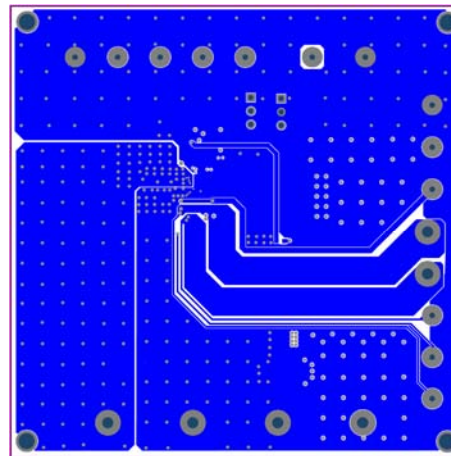

Figure 4— Bottom Layer

QUICK START GUIDE

1. Connect the positive and negative terminals of the load to the VOUT and GND pins, respectively.
2. Preset the one power supply output between 4.5V and 24V as VIN, and another power supply to 3.3V as external 3.3V VCC, and then turn off the power supply.
3. Connect the positive and negative terminals of the VIN power supply output to the VIN and GND pins, respectively.
4. Connect the positive and negative terminals of the power 3.3V supply output to the 3V3 and AGND Pins, respectively.
5. Turn the VIN and 3V3 power supply on. The NB685A will automatically startup.
6. To use the Enable function, apply a digital input to the EN1/EN2 pin. Drive EN1 (for VTT) /EN2 (for VDDQ) to 3.3V to turn on the regulator or less than 0.4V to turn it off.

NOTICE: The information in this document is subject to change without notice. Users should warrant and guarantee that third party Intellectual Property rights are not infringed upon when integrating MPS products into any application. MPS will not assume any legal responsibility for any said applications.