

DESCRIPTION

The NB685 provides a complete power supply for DDR3, DDR3L, LPDDR3, and DDR4 memory with the highest power density. It integrates a high frequency synchronous rectified step-down switch mode converter (VDDQ) with a 1A sink/source LDO (VTT) and buffered low noise reference (VTTREF).

Adaptive Constant-On-Time (COT) control mode provides fast transient response and eases loop stabilization. The DC auto tune loop provides good load and line regulation.

The VTT LDO provides 1A sink/source current capability and requires only 10uF ceramic capacitance. The VTTREF tracks VDDQ/2 with an excellent 1% accuracy.

Full protection features include OC Limit, OVP, UVP and thermal shut down and Over temperature warning (OTW).

The converter requires minimum number of external components and is available in QFN 3x3 packages.

FEATURES

- Wide 4.5V to 26V Operating Input Range
- Compatible for IMVP8
- 100uA low quiescent Current
- 12A Continuous Output Current
- Selectable Ultrasonic Mode
- Selectable 500k/700k Switching Frequency
- Built-in +/- 1A VTTLDO
- 1% Buffered VTTREF Output
- Adaptive COT for Fast transient
- DC Auto Tune Loop
- Stable with POSCAP and Ceramic Output Cap
- Over Temperature Warning
- Internal Soft Start
- Output Discharge
- OCL, OVP, UVP, OTP
- Latch off Reset via EN or Power Cycle

APPLICATIONS

- Laptop Computer
- Networking Systems and Server
- Distributed Power Systems

All MPS parts are lead-free and adhere to the RoHS directive. For MPS green status, please visit MPS website under Products, Quality Assurance page. "MPS" and "The Future of Analog IC Technology" are registered trademarks of Monolithic Power Systems, Inc.

EVNB685-Q-00A EVALUATION BOARD



(L x W) 85mm x 85mm

Board Number	MPS IC Number
EVNB685-Q-00A	NB685

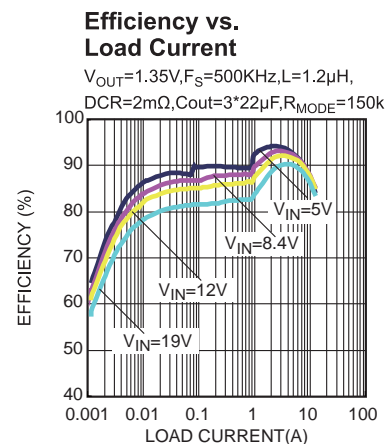

EVALUATION BOARD SCHEMATIC

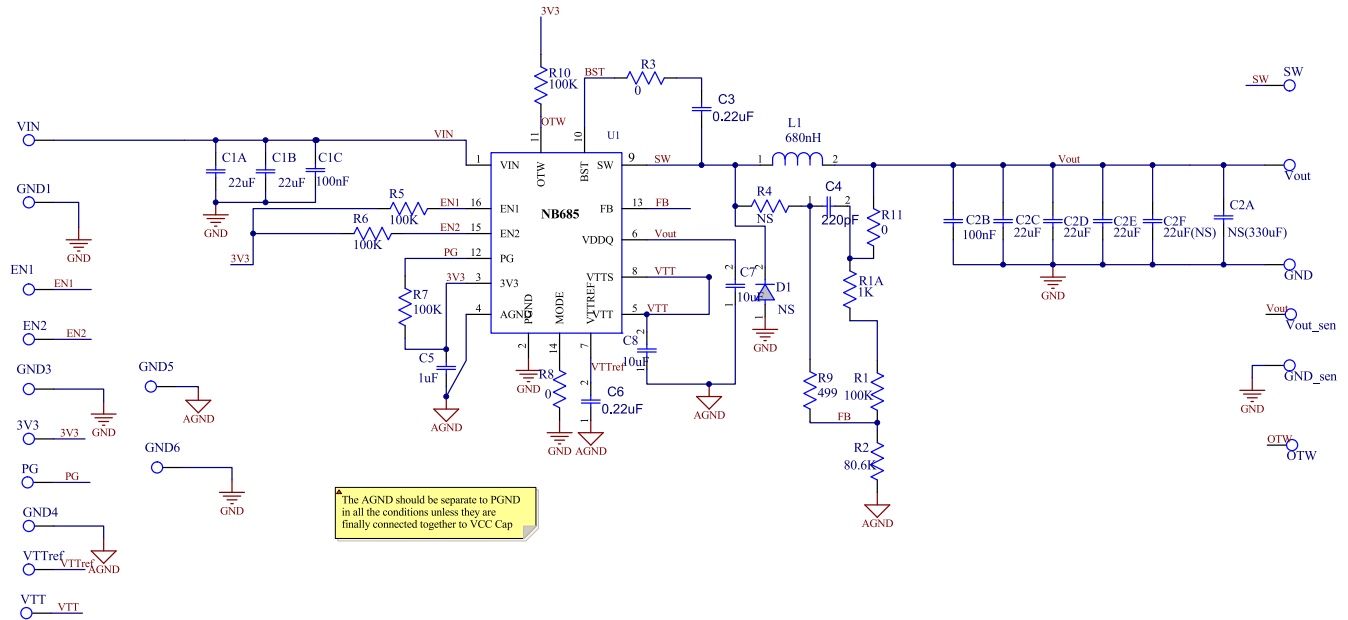

$V_{IN}=19V, V_{OUT}=1.35V, I_{O-MAX}=12A$

EVNB685-Q-00A BILL OF MATERIALS

Qty	Des	Value	Description	Package	Manufacture	Manufacture_PN
2	C1A, C1B	22uF	Ceramic Capacitor;25V; X5R;1206;	1206	muRata	GRM32ER61E226KE15L
2	C1C, C2B	100nF	Ceramic Capacitor;50V; X7R;0603;	603	muRata	GRM188R71H104KA93D
2	C2A, C2F	NS				
3	C2C, C2D, C2E	22uF	Ceramic Capacitor;6.3V; X5R	0805	Murata	GRM21BR60J226ME39L
2	C3, C6	220nF	50V; X7R;0402	0402	Taiyo Yuden	UMK105BJ224KV-F
1	C4	220pF	Ceramic Capacitor;50V; C0G;0603	0603	muRata	GRM1885C1H221JA01D
1	C5	1uF	Ceramic Capacitor;6.3V; X5R;0603	0603	muRata	GRM188R60J105KA01D
2	C7,C8	10uF	Ceramic Capacitor;6.3V; X5R;0805	805	muRata	GRM21BR70J106KE76L
1	R1	100K	Film Resistor;1%	0603	Yageo	RC0603FR-07100KL
1	R2	80.6K	Film Resistor;1%	0603	Yageo	RC0603FR-0780K6L
1	R3	0	Film Resistor;5%;	0603	Yageo	RC0603JR-070RL
1	R4	NS				
4	R5, R6, R7, R10	100K	Film Resistor;1%	0402	Yageo	RC0402FR-07100KL
2	R8, R11	0	Film Resistor;1%	0603	Yageo	RC0603FR-070RL
1	R9	499	Film Resistor;1%	0603	Yageo	RC0603FR-07499RL
1	R1A	1K	Film Resistor;1%	0603	Yageo	RC0603FR-071KL
1	L1	0.68uH	Inductor;680nH; 3.1m;17A	SMD	Würth	744311068
1	D1	NS				
1	U1	NB685	NB685	QFN3*3	MPS	NB685

PRINTED CIRCUIT BOARD LAYOUT

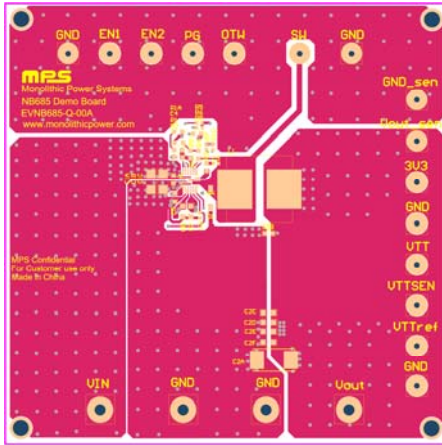

Figure 1—Top Layer

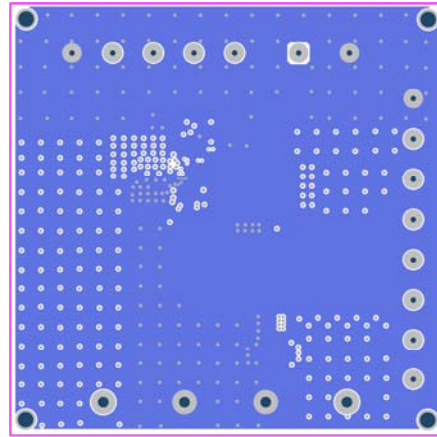

Figure 2—Inner Layer 1

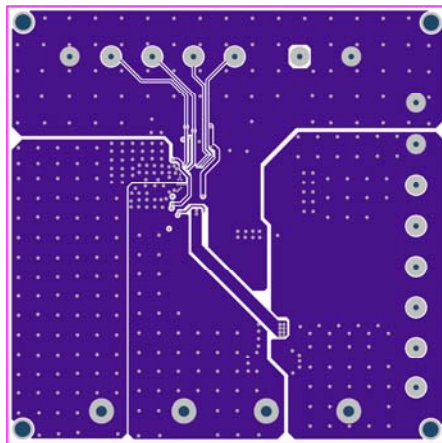

Figure 3—Inner Layer 2

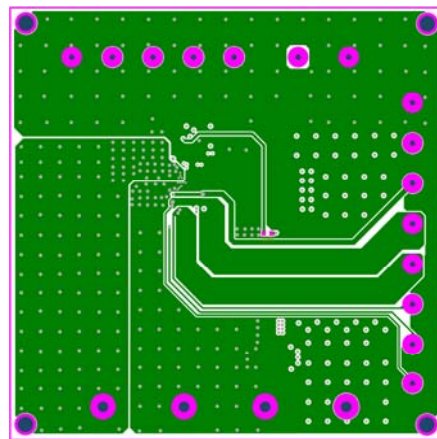

Figure 4— Bottom Layer

QUICK START GUIDE

1. Connect the positive and negative terminals of the load to the VOUT and GND pins, respectively.
2. Preset the one power supply output between 4.5V and 24V as VIN, and another power supply to 3.3V as external 3.3V VCC, and then turn off the power supply.
3. Connect the positive and negative terminals of the VIN power supply output to the VIN and GND pins, respectively.
4. Connect the positive and negative terminals of the power 3.3V supply output to the 3V3 and AGND Pins, respectively.
5. Turn the VIN and 3V3 power supply on. The NB685 will automatically startup.
6. To use the Enable function, apply a digital input to the EN1/EN2 pin. Drive EN1/EN2 to 3.3V to turn on the regulator or less than 0.4V to turn it off.

NOTICE: The information in this document is subject to change without notice. Users should warrant and guarantee that third party Intellectual Property rights are not infringed upon when integrating MPS products into any application. MPS will not assume any legal responsibility for any said applications.