

### DESCRIPTION

The NB681 is a fully integrated high frequency synchronous rectified step-down switch mode converter with 2-Bit VID especially designed for V1.0A, VCCIO, PRIMCORE, EDRAM and EOPIO for IMVP8 applications. It offers very compact solution to achieve 6A continuous output current and 7.5A peak output current over a wide input supply range.

The NB681 operates at high efficiency over a wide output current load rang based on MPS proprietary switching loss reduction tech and internal Low Ron Power MOSFETs

Adaptive Constant-On-Time (COT) control mode provides fast transient response and eases loop stabilization. The DC auto tune loop provides good load and line regulation.

NB681 also provides a Low Power Mode for power loss saving during the low power state and Ultrasonic Mode to avoid audible noise.

Full protection features include OC Limit, OVP, UVP and thermal shut down.

The converter requires minimum number of external components and is available in QFN 2x3 packages.

### FEATURES

- Wide 4.5V to 26V Operating Input Range
- V1.0A/VCCIO/PCH/EDRAM/EOPIO compatible for IMVP8
- Output adjustable by 2-Bit VID
- Low Power Mode/25uA low quiescent Current
- 6A Continous Output Current
- 7.5A Peak Output Current
- Selectable Ultrasonic Mode
- Adaptive COT for Fast transient
- DC Auto Tune Loop
- Stable with POSCAP and Ceramic Cap
- 1% Reference Voltage
- Internal Soft Start and Output Discharge
- OCL, OVP, UVP Protection and Thermal Shutdown
- Latch off reset via EN or Power Cycle

### APPLICATIONS

- Notebook Systems and Tablet PC
- Networking Systems and Server
- Personal Video Recorders
- Distributed Power Systems

All MPS parts are lead-free, halogen free, and adhere to the RoHS directive. For MPS green status, please visit MPS website under Quality Assurance.

"MPS" and "The Future of Analog IC Technology" are Registered Trademarks of Monolithic Power Systems, Inc.

## EVNB681-D-01A EVALUATION BOARD

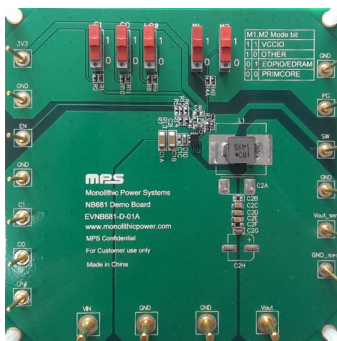

(L x W) 85mm x 85mm

Board Number	MPS IC Number
EVNB681-D-01A	NB681

### Efficiency vs. Output Current

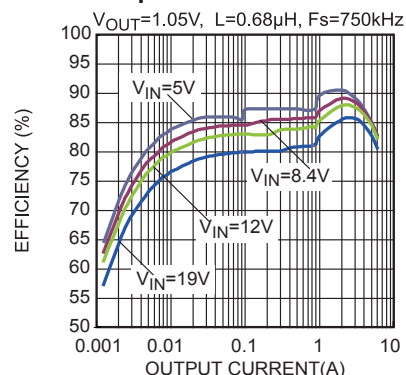

# EVALUATION BOARD SCHEMATIC

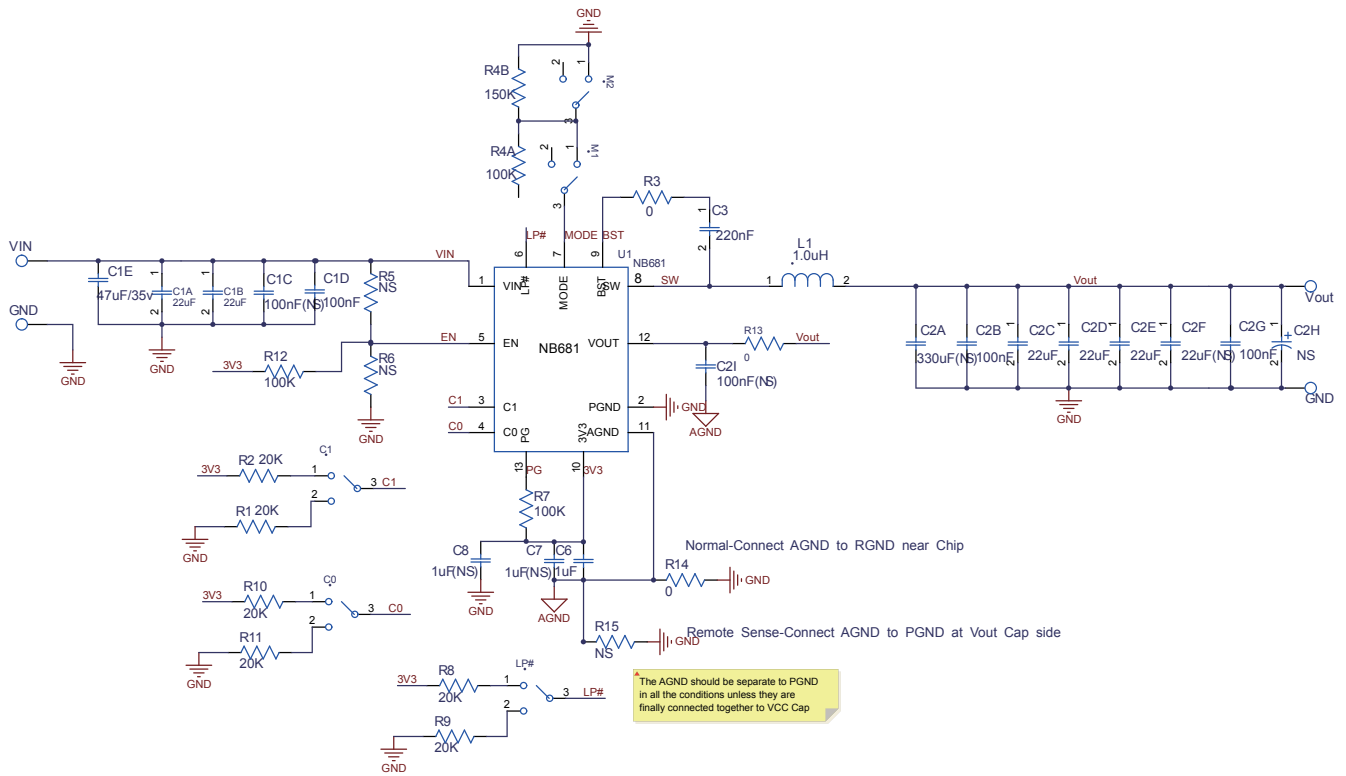

**EVNB681-D-01A BILL OF MATERIALS**

Qty	Des	Value	Description	Package	Manufacture	Manufacture_PN
2	C1A, C1B	22 $\mu$ F	Ceramic Capacitor;25V;X5R;	1206	muRata	GRM21BR61E226KE15
2	C1D,C2G	100nF	Ceramic Capacitor;50V;X7R;	0603	muRata	GRM188R71H104KA93D
1	C1E	47 $\mu$ F	Ceramic Capacitor;35V	SMD	AVX	TAJE476K035RNJ
6	C1C,C2A,C2B,C2F,C2H,C2I	NS				
3	C2C,C2D,C2E	22 $\mu$ F	Ceramic Capacitor;6.3V;X5R	0805	muRata	GRM21BR60J226ME39L
1	C3	220nF	Capacitor;25V;X5R	0402	muRata	GRM155R61E224KA87D
1	C6	1 $\mu$ F	Ceramic Capacitor;6.3V;X5R;	0603	muRata	GRM188R60J105KA01D
2	C7,C8	NS				
6	R1,R2,R8,R9,R10,R11	20k	Film Resistor;1%	0402	Yageo	RC0402FR-0720KL
1	R3	0	Film Resistor;1%	0603	Yageo	RC0603FR-070RL
2	R13,R14	0	Film Resistor;1%	0402	Yageo	RC0402FR-070RL
3	R5,R6,R15	NS				
3	R4A,R7,R12	100k	Resistor;1%;1/16W	0402	Yageo	RC0402FR-07100KL
1	R4B	150k	Resistor;1%;1/16W	0402	Yageo	RC0402FR-07150KL
1	L1	1 $\mu$ H	Inductor;1uH;8.5m;9.5A	SMD	TOKO	FDVE0603-1R0M
1	D1	NS				
1	U1	NB681	NB681	QFN2*3	MPS	NB681
5	C1,C0,LP#,M1,M2	450301014042	Switch	DIP		450301014042

PRINTED CIRCUIT BOARD LAYOUT

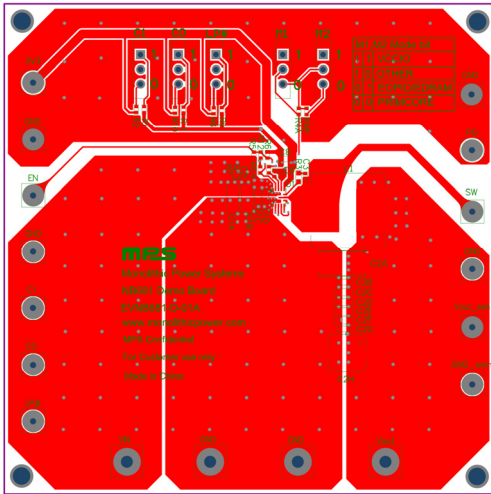

Figure 1—Top Layer and Silk

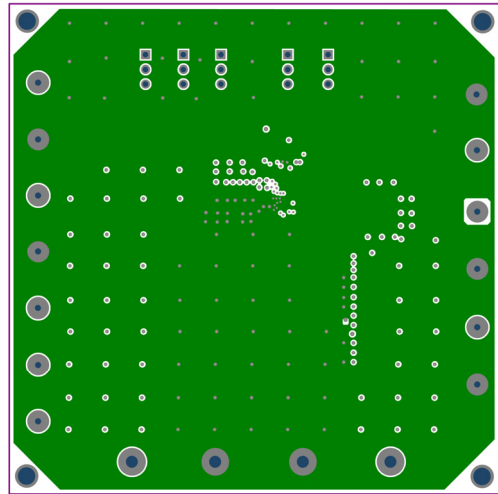

Figure 2—Inner Layer 1

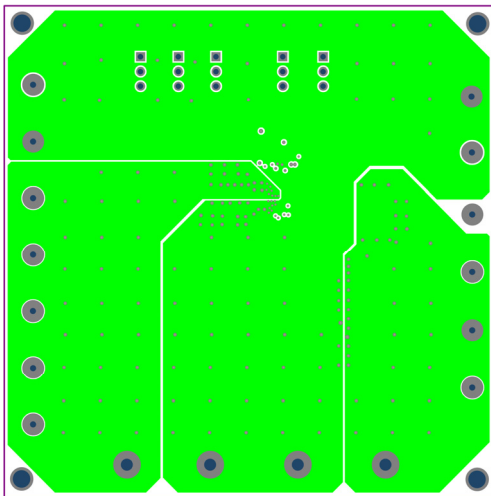

Figure 3—Inner Layer 2

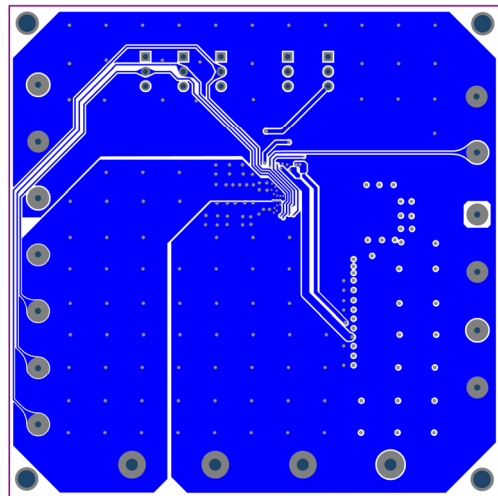

Figure 4—Bottom Layer

## QUICK START GUIDE

1. Connect the positive and negative terminals of the load to the VOUT and GND pins, respectively.
2. Preset the one power supply output between 4.5V and 24V as VIN, and another power supply to 3.3V as external 3.3V VCC, and then turn off the power supply.
3. Connect the positive and negative terminals of the VIN power supply output to the VIN and GND pins, respectively.
4. Connect the positive and negative terminals of the power 3.3V supply output to the 3V3 and AGND Pins, respectively.
5. Turn both the VIN and 3V3 power supply on. The NB681 will automatically startup.
6. To use the Enable function, apply a digital input to the EN pin. Drive EN to 3.3V to turn on the regulator or less than 0.4V to turn it off.
7. Refer to the DS for 2-Bit VID, LP# mode and USM mode operation.

## VID TABLE

Mode	LP#	C0	C1	Vout(V)
<b>VCCIO</b> <b>M1=1,M2=1</b> <b>Rmode=0Ω</b>	0	X	X	0
	1	0	0	0.85
	1	1	0	0.875
	1	0	1	0.95
	1	1	1	0.975
<b>VCC_PRIMCORE(PCH)</b> <b>M1=0,M2=0</b> <b>(Rmode=Float)</b>	0	X	X	0.7
	1	0	0	0.85
	1	1	0	0.9
	1	0	1	0.95
	1	1	1	1
<b>EDRAM/EOPIO</b> <b>M1=0,M2=1</b> <b>(Rmode=100k)</b>	0	X	X	0
	1	0	0	0.8
	1	1	0	0.95
	1	0	1	1
	1	1	1	1.05
<b>Others</b> <b>M1=1,M2=0</b> <b>Rmode=150k</b>	0	X	X	0
	1	0	0	1
	1	1	0	1.05
	1	0	1	1.15
	1	1	1	1.2

**NOTICE:** The information in this document is subject to change without notice. Users should warrant and guarantee that third party Intellectual Property rights are not infringed upon when integrating MPS products into any application. MPS will not assume any legal responsibility for any said applications.