

## DESCRIPTION

The EVKT7770-3.1CH-00A is an evaluation board for the MP7770, a 3.1 channel amplifiers demo board.

There are 4 channels (3pcs MP7770) for the subwoofer speaker, center speaker, the left front and right front speakers. The subwoofer channel and center channel are with BTL output configuration, and other two channels are with SE output configuration.

For more MP7770 operation information, please refer to the MP7770 datasheet.

## ELECTRICAL SPECIFICATIONS

Parameter	Value
Input Voltage VCC	19 – 30V
Number of channels	2 x SE, 2 x BTL
Max. output current	5.5A

## FEATURES

- Wide 19V to 30V Input Voltage Range
- Output Power at 10%THD:
  - 102W at 19.5V (Stereo SE: 2 x 16W into 3Ω Load, Stereo BTL: 2 x 35W into 6Ω Load)
  - 153W at 24V (Stereo SE: 2 x 24.5W into 3Ω Load, Stereo BTL: 2 x 52W into 6Ω Load)
  - 242W at 30V (Stereo SE: 2 x 39W into 3Ω Load, Stereo BTL: 2 x 82W into 6Ω Load)
- Low noise, >100dB DNR
- Integrated Pop Elimination Circuit
- Thermal and Short-Circuit Protection

## APPLICATIONS

- DVD Receiver
- Mini Combo System
- Home Theater Systems
- Audio Docking or High-Power Sound Box

All MPS parts are lead-free, halogen free, and adhere to the RoHS directive. For MPS green status, please visit MPS website under Quality Assurance. "MPS" and "The Future of Analog IC Technology" are Registered Trademarks of Monolithic Power Systems, Inc.

## EVKT7770-3.1CH-00A

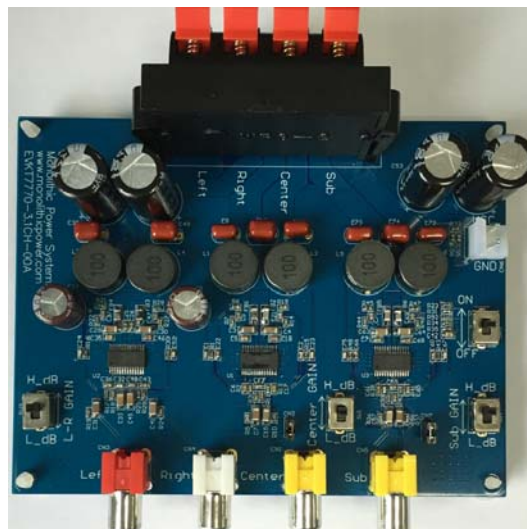

(L x W x H) 4.92" x 4.61" x 1.50"  
12.5cm x 11.7cm x 3.8cm

Board Number	MPS IC Number
EVKT7770-3.1CH-00A	MP7770

EVKT7770-3.1CH-00A BOARD SCHEMATIC

Sub-CH

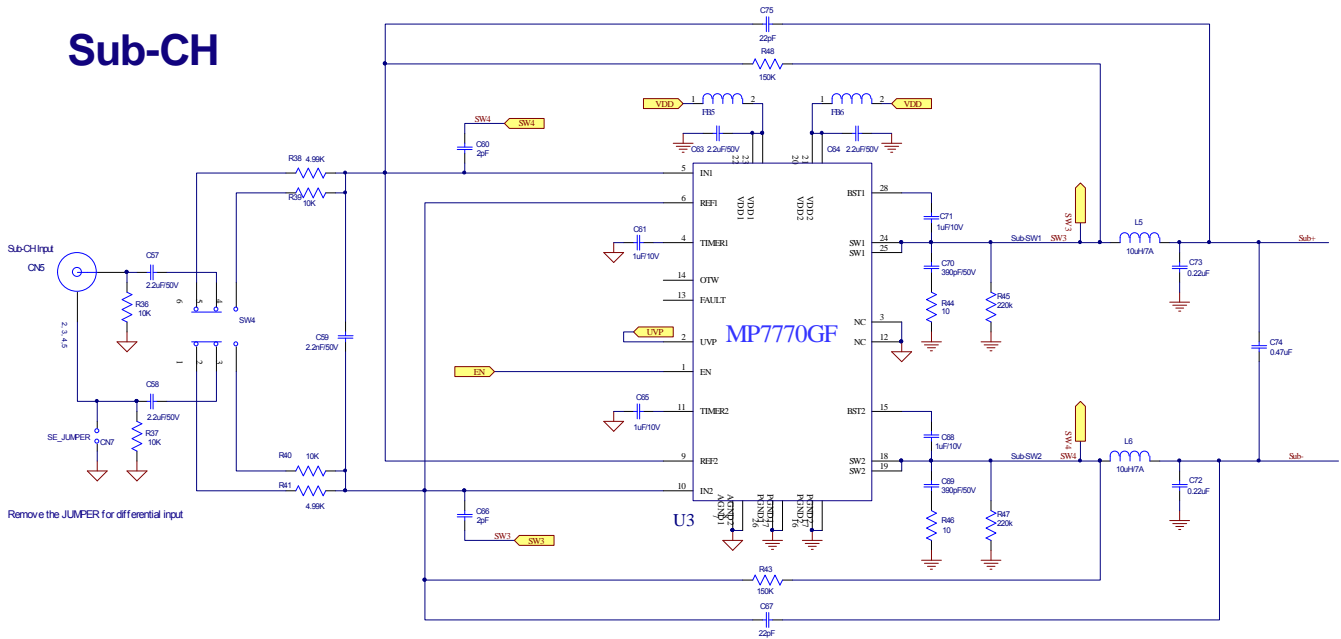

Center CH

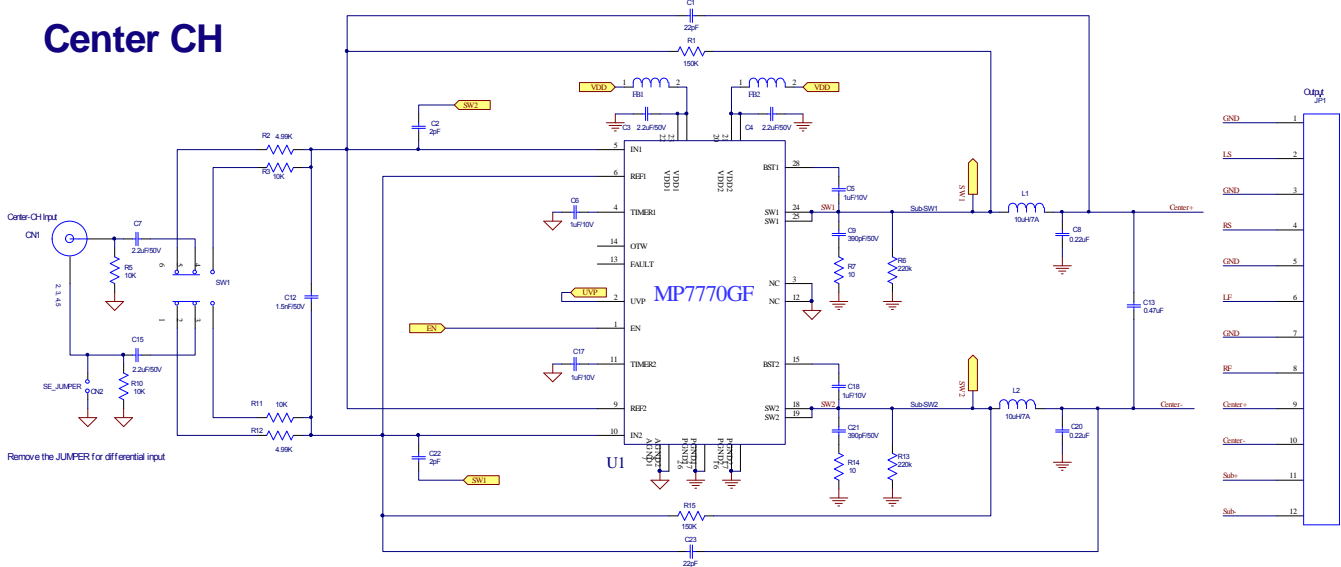

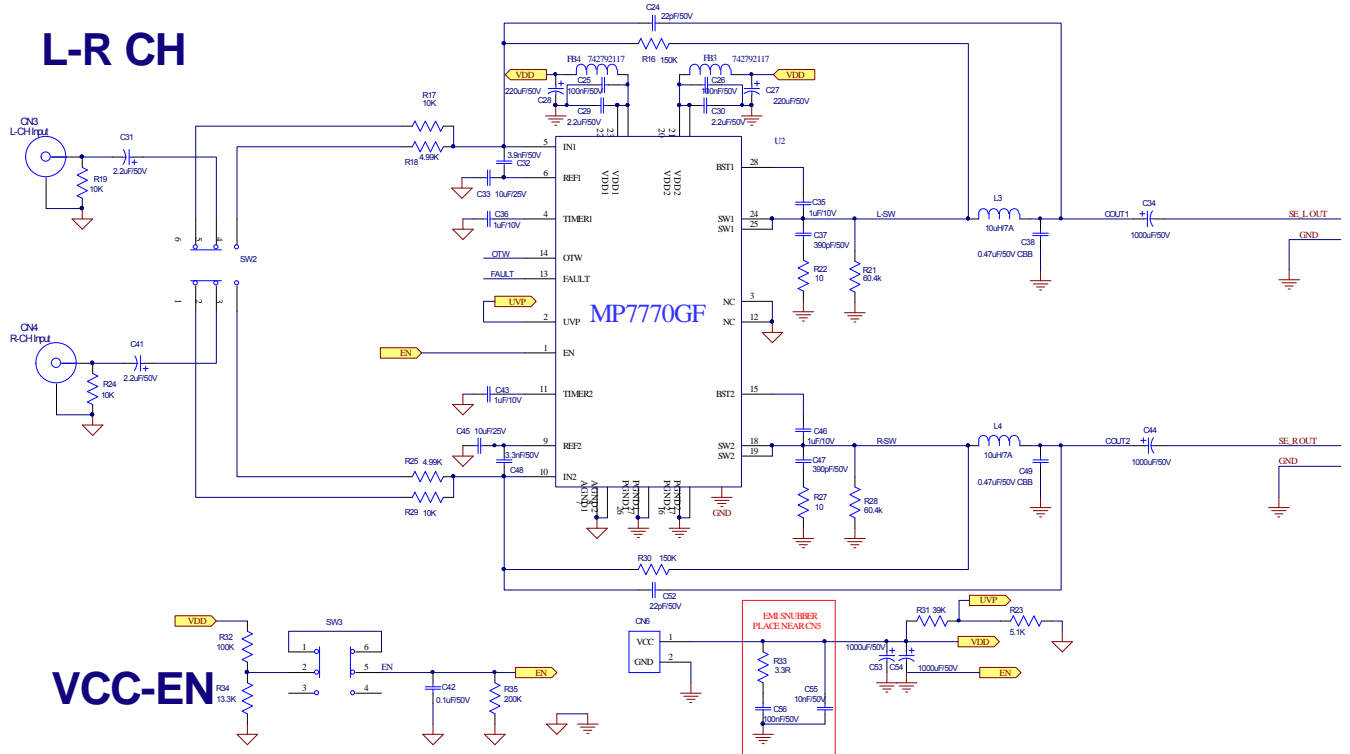

## EVKT7770-3.1CH-00A BOARD BILL OF MATERIALS

Qty	Ref	Value	Description	Package	Manufacturer	Part Number
6	C1, C23, C24, C52, C67, C75	22pF/50V	Ceramic Capacitor; 50V;C0G;0603	0603	TDK	C1608C0G1H220J
4	C2, C22, C60, C66	2pF/50V	Ceramic Capacitor; 50V;C0G;0603	0603	TDK	C1608C0G1H020CT
12	C3, C4, C7, C15, C29, C30, C31, C41 C63, C64, C57, C58	2.2μF/50V	Ceramic Capacitor; 50V;X7R;1206	1206	muRata	GRM31CR71H225KA88L
12	C5, C6, C17, C18, C35, C36, C43, C46, C61, C65, C68, C71	1μF/10V	Ceramic Capacitor; 10V;X7R	0603	Murata	GRM188R71A105KA61D
4	C8, C20, C72, C73	0.22μF/50V /CBB	Capacitor;50V;CBB	DIP	Panasonic	ECQV1H224JL
6	C9, C21, C37, C47, C69, C70	390pF/50V	Ceramic Capacitor; 50V;C0G;0603	0603	TDK	C1608C0G1H391J
1	C12	1.5nF/50V	Ceramic Capacitor; 50V;C0G;0603;	0603	muRata	GRM188R71H153KA01D
1	C59	2.2nF/50V	Ceramic Capacitor; 50V;C0G;0603;	0603	muRata	C1608X7R1H222K
4	C13, C74, C38, C49	0.47μF/50V /CBB	Capacitor;50V;CBB	DIP	Panasonic	ECQV1H474JL
4	C25, C26, C56, C42	0.1μF/50V	Ceramic Capacitor; 50V;X7R;0603	0603	muRata	GRM188R71H104KA93D
1	C42	0.1μF/50V	Ceramic Capacitor; 50V;X7R;0805	0805	muRata	GRM21BR71H104KA01L
2	C27, C28	220μF/50V	Electrolytic Capacitor; 50V;Electrolytic	DIP	Rubycon	Lk 220uF/50V 10*12.5
1	C32	3.9nF/50V	Ceramic Capacitor; 50V;X7R;0603	0603	muRata	GRM188R71H392KA01D
2	C33, C45	10μF/50V	Ceramic Capacitor; 50V;X5R;1206;	1206	muRata	GRM31CR61H106KA12L
4	C34, C44, C53, C54	1000μF/50V	Electrolytic Capacitor; 50V;Electrolytic	DIP	Rubycon	1000uF/50V
1	C48	3.3nF/50V	Ceramic Capacitor; 50V;X7R;0603	0603	TDK	C1608X7R1H332K
1	C55	10nF/50V	Ceramic Capacitor; 50V;C0G;0603	0603	TDK	GRM188R71H103KA01D
6	R1, R15, R16, R30, R43, R48	150k	Film Resistor;1%	0603	Yageo	RC0603FR-07150KL

**EVKT7770-3.1CH-00A BOARD BILL OF MATERIALS**

Qty	Ref	Value	Description	Package	Manufacturer	Part Number
6	R2, R12, R18, R25, R38, R41	4.99k	Film Resistor;1%	0603	Yageo	RC0603FR-074K99L
12	R3, R5, R10, R11, R17, R19, R24, R29, R36, R37, R39, R40	10k	Film Resistor;1%	0603	Yageo	RC0603FR-0710KL
4	R6, R13, R45, R47	220k	Resistor;1%	0603	Royalohm	RC0603FR-07220KL
6	R7, R14, R22, R27, R44, R46	10	Film Resistor;1%	0603	Yageo	RC0603FR-0710RL
2	R21, R28	60.4k	Film Resistor;1%	0603	Yageo	RC0603FR-0760K4L
1	R23	5.1k	Film Resistor;1%;	0603	Yageo	RC0603FR-075K1L
1	R31	39k	Film Resistor;1%;	0603	Yageo	RC0603FR-0739KL
1	R32	100k	Film Resistor;1%	0603	Yageo	RC0603FR-07100KL
1	R33	3.3R	Film Resistor;1%	0603	Yageo	RC0603JR-073R3L
1	R34	13.3k	Film Resistor;1%	0603	Yageo	RC0603FR-0713K3L
1	R35	200k	Film Resistor;1%	0603	Yageo	RC0603FR-07200KL
2	CN1, CN5	RCA yellow	Connector	DIP	Any	
2	CN2, CN7	2Pin 2.54mm Connector	Connector	DIP	Any	
1	CN3	RCA red	Connector	DIP	Any	
1	CN4	RCA white	Connector	DIP	Any	
1	CN6	Connector	VCC GND Connector	DIP	Any	
6	FB1, FB2, FB3, FB4, FB5, FB6	BLM31PG3 30SN1	Magnetic Bead;6A	1206	Wurth	BLM31PG330SN1
1	JP1	{Value}	CONN/8PIN/2MM			
6	L1, L2, L3, L4, L5, L6	10 $\mu$ H/6.2A	Inductor;10uH;12.9 mOhm;6.2A	DIP	Wurth	744750420100
4	SW1, SW2, SW3, SW4	DPDT SWITCH	Connector	DIP	Any	
3	U1, U2, U3	MP7770/TS SOP28/EP	IC	TSSOP2 8/EP	MPS	MP7770GF

**EVKT7770-3.1CH-00A PRINTED CIRCUIT BOARD LAYOUT**

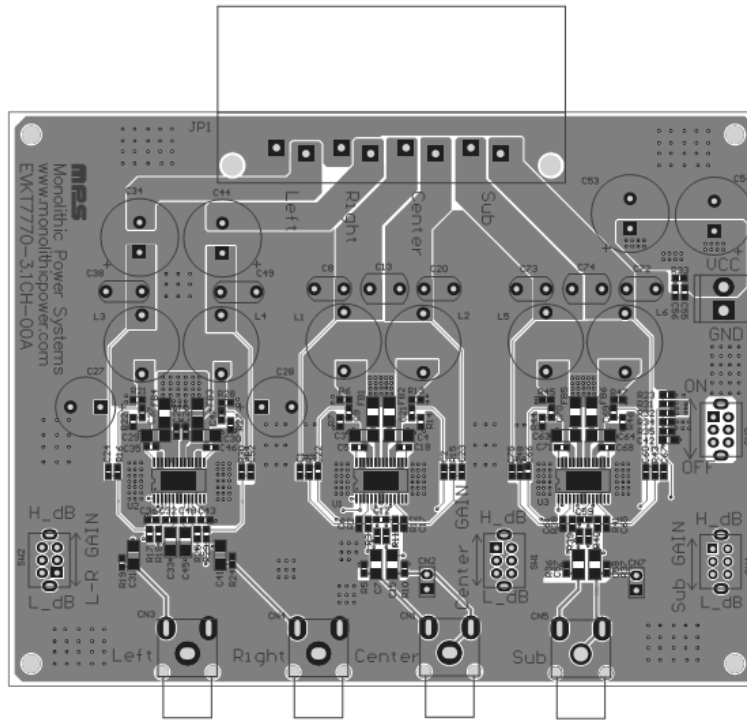

**Figure 1—Top layer**

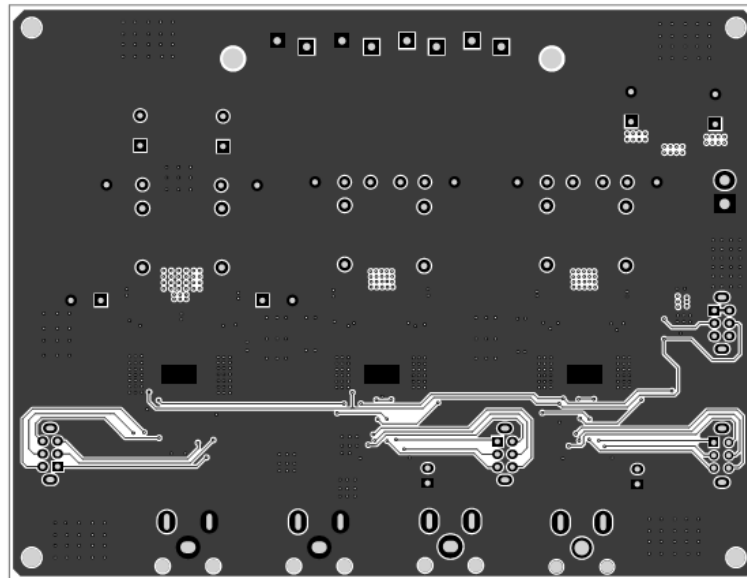

**Figure 2—Mid layer1**

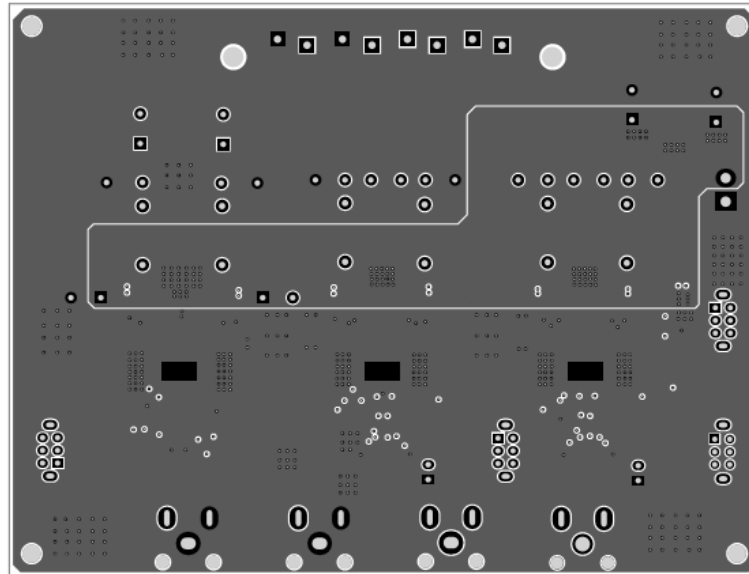

Figure 3— Mid layer 2

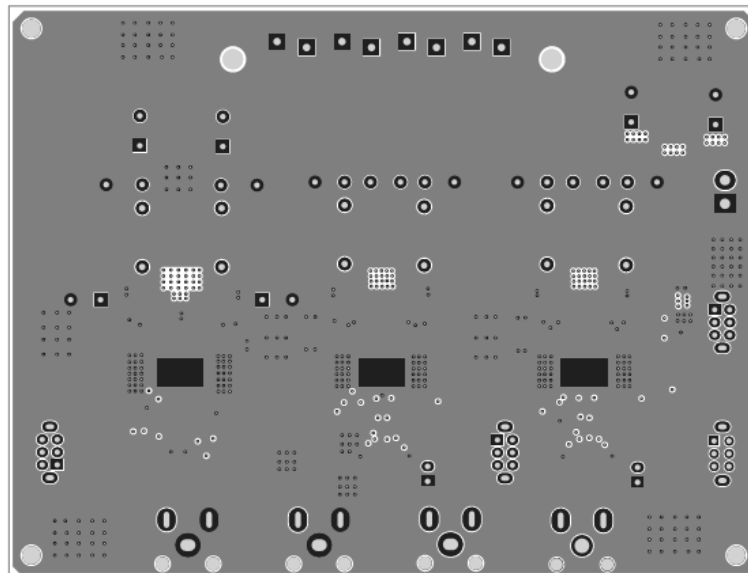

Figure 4—Bottom layer

## QUICK START GUIDE

1. This board is 3.1 channel amplifiers demo board, subwoofer channel and center channel with BTL output configuration, and Left Front / Right Front channels with SE output configuration. Please see connection guideline as below figure.

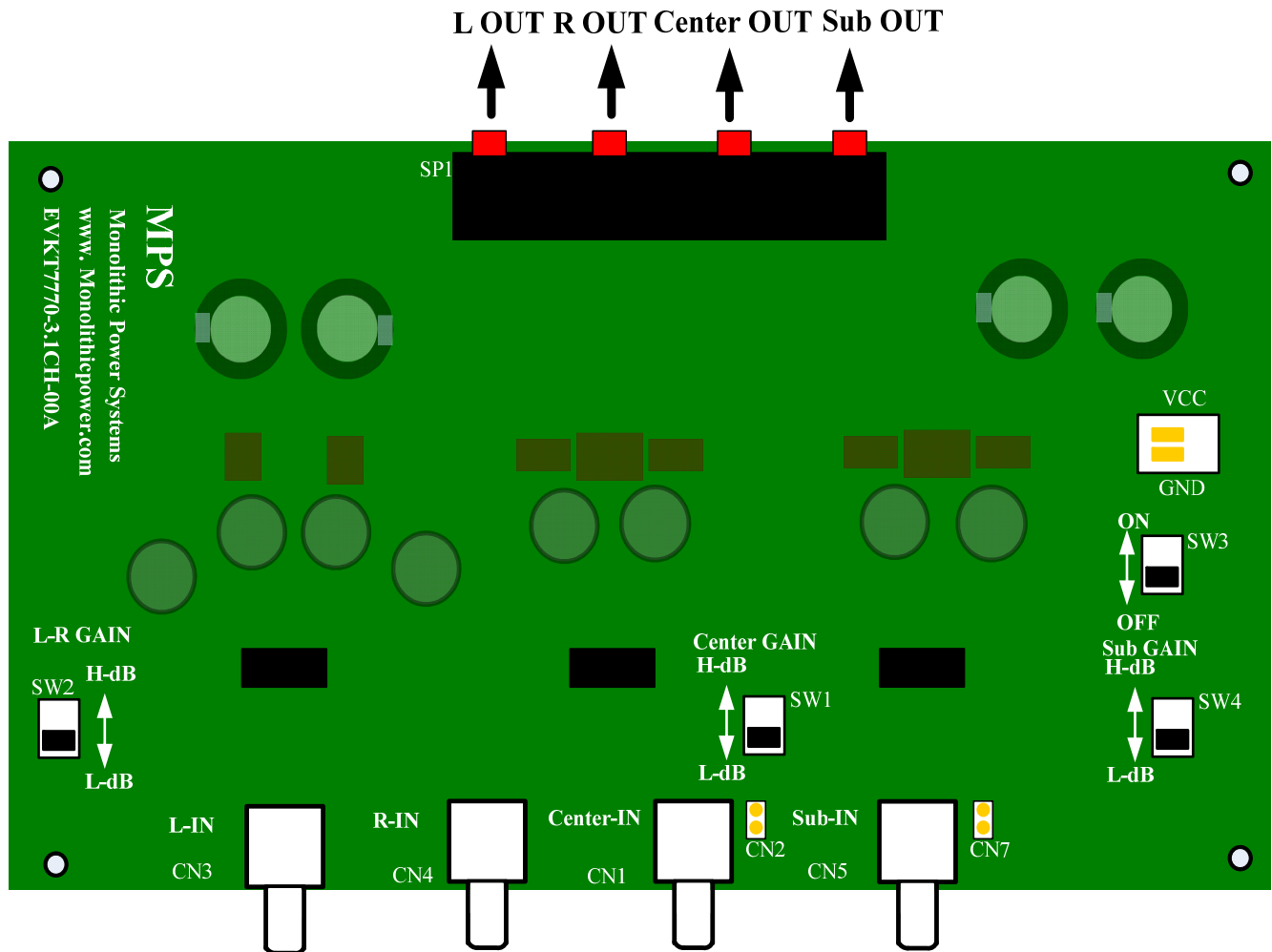

Figure 5—Connection for Normal Application (Top View)

### 2. Power Requirements

- Power supply: 19V to 30V, 15A. (If the VDD changed, please see MP7770 datasheet for detail UVP configuration for best pop performance.)
- 0V to 1.8VRMS (max) audio signal source.
- Speaker: typical 6~8ohm for subwoofer channel; typical 3~8ohm for other 2 SE channels

### 3. Setup Condition and turn on sequence

- Set the input configuration for subwoofer/Center channel: if the input signal is single-ended, install the CN2/CN7; if the input signal is differential, keep CN2/CN7 not connected. The input signals of other two channels are all single-ended configuration. Connect the audio input signal sources to the corresponding inputs. Default setup: CN2/CN7 is shorted.



Table1: Jumper CN2/CN7 Operating Description

Jumper	Description
CN2,CN7	Connected: select the SE input configuration for subwoofer channel and center channel, positive input of sub channel and center channel are connected to GND.  not connected: select the differential input for Subwoofer channel and center channel.

- Volume Control (SW1,SW2 and SW4 can adjust the amplifier's GAIN)

Table2: SW1, SW2 and SW4 adjust the GAIN Description

	Channel	GAIN(V/V)
SW1(BTL)	subwoofer	L-dB: 15 H-dB: 30
SW4(BTL)	Center	L-dB: 15 H-dB: 30
SW2(SE)	Left front	L-dB: 15 H-dB: 30
	Right front	L-dB: 15 H-dB: 30

- Connect the outputs to the corresponding external speakers.
- Set the ENABLE switch to disable (SW3)
- Connect the power supply to the VDD terminals, or turn on the power supply to apply power to the board.
- Set the ENABLE switch to enable the amplifiers.

#### 4. Turn-Off Sequence

- Switch the ENABLE at disable position.
- Turn off power supply.

**NOTICE:** The information in this document is subject to change without notice. Users should warrant and guarantee that third party Intellectual Property rights are not infringed upon when integrating MPS products into any application. MPS will not assume any legal responsibility for any said applications.