

DESCRIPTION

The EV9403EN-00A is an evaluation board for the MP9403, a monolithic synchronous buck regulator. The MP9403 integrates a 150mΩ high-side MOSFET and a 100mΩ low-side MOSFET that provide 3A continuous load current over input voltage of 4.3V to 7V. Current mode control provides fast transient response and cycle-by-cycle current limit. An adjustable soft-start prevents inrush current at turn-on. In shutdown mode, the supply current drops to 1μA.

This device, available in an 8-pin SOIC package, provides a very compact system solution with minimal reliance on external components.

ELECTRICAL SPECIFICATIONS

Parameter	Symbol	Value	Units
Input Voltage	V_{IN}	4.3-7	V
Output Voltage	V_{OUT}	2.5	V
Output Current	I_{OUT}	3	A

FEATURES

- 3A Output Current
- 4.3V to 7V Operating Input Range
- 2.5V Output, Adjustable from 0.80V to 5.50V
- Up to 93% Efficiency
- Fixed 250kHz Frequency
- All Ceramic Input and Output Capacitors
- Programmable Soft-Start
- Input Under Voltage Lockout

APPLICATIONS

- Distributed Power Systems Handheld
- Networking Systems
- FPGA, DSP, ASIC Power Supplies
- Pre-Regulator for Linear Regulators
- Notebook Computers

"MPS" and "The Future of Analog IC Technology" are Registered Trademarks of Monolithic Power Systems, Inc.

EV9403EN-00A EVALUATION BOARD



(L x W x H) 2.1" x 1.3" x 0.3"

Board Number	MPS IC Number
EV9403EN-00A	MP9403EN

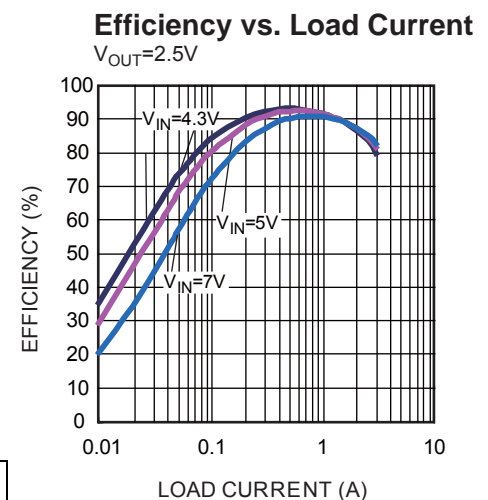

EVALUATION BOARD SCHEMATIC

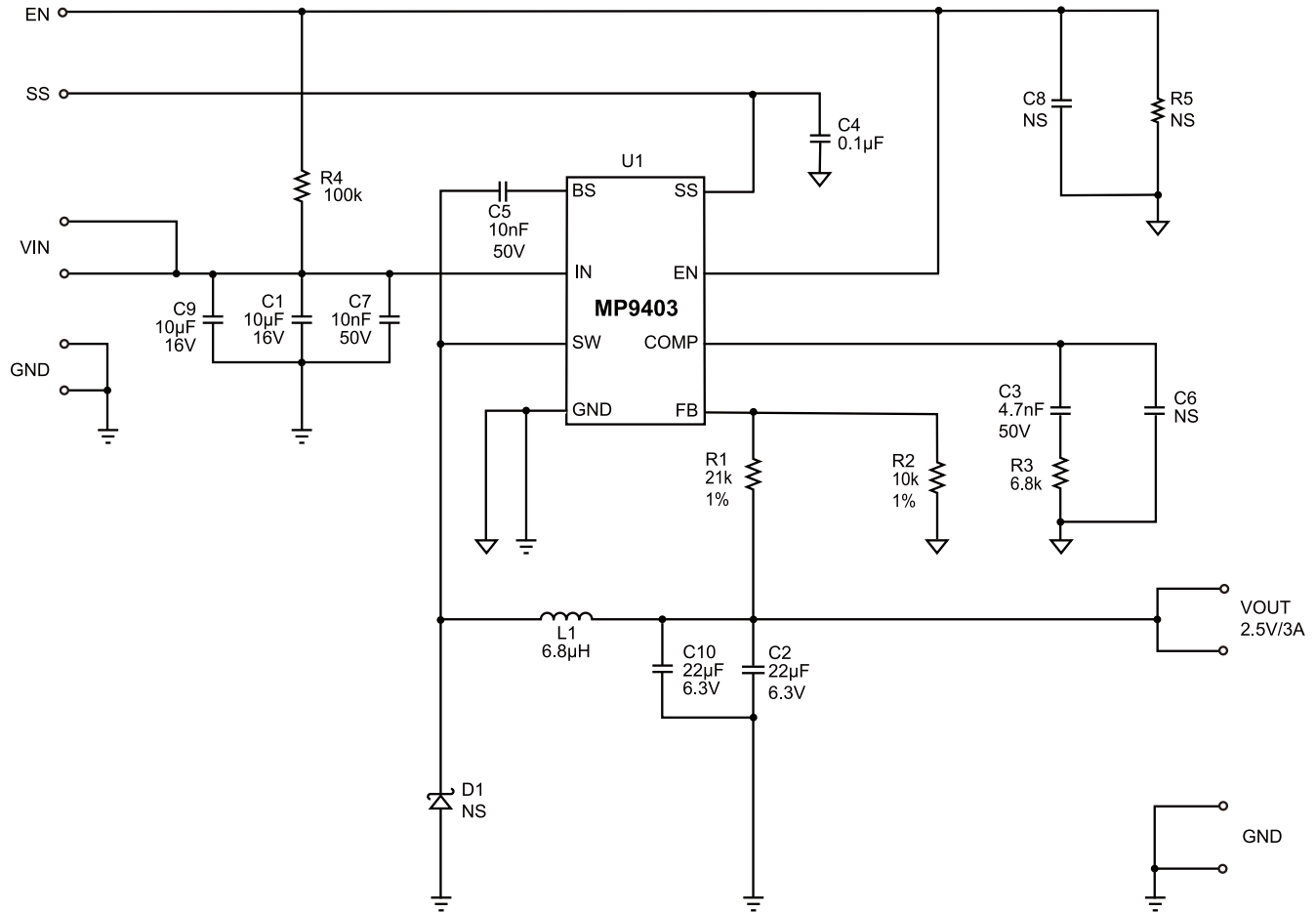

EV9403EN-00A BILL OF MATERIALS

Qty	Ref	Value	Description	Package	Manufacturer	Manufacturer P/N
2	C1, C9	10µF	Ceramic Cap, 16V, X7R	1210	TDK	C3225X7R1E106K
2	C2, C10	22µF	Ceramic Cap, 6.3V, X5R	1210	Murata	GRM32DR60J226M
1	C3	4.7nF	Ceramic Cap, 50V, X7R	0603	TDK	C1608X7R1H472K
1	C4	0.1µF	Ceramic Cap, 50V, X7R	0603	TDK	C1608X7R1H104K
2	C5, C7	10nF	Ceramic Cap, 50V, X7R	0603	TDK	C1608X7R1H103K
0	C6,C8		Do Not Stuff			
0	D1		Do Not Stuff			
1	L1	6.8µH	Inductor, 4.5A	SMD	TDK	VLF10040T-6R8N4R5
1	R1	21kΩ	Film Res, 1%	0603	Yageo	RC0603FR-0721KL
1	R2	10kΩ	Film Res, 1%	0603	Yageo	RC0603FR-0710KL
1	R3	6.8kΩ	Film Res, 1%	0603	Yageo	RC0603FR-076K8L
1	R4	100kΩ	Film Res, 1%	0603	Yageo	RC0603FR-07100KL
0	R5		Do Not Stuff			
1	U1		DC-DC Converter	SOIC8E	MPS	MP9403EN

PRINTED CIRCUIT BOARD LAYOUT

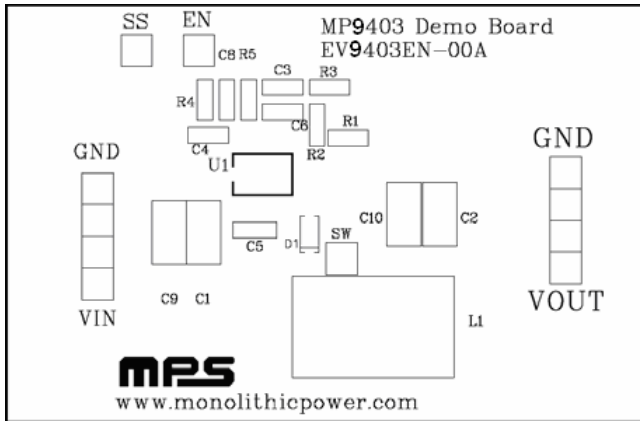

Figure 1—Top Silk Layer

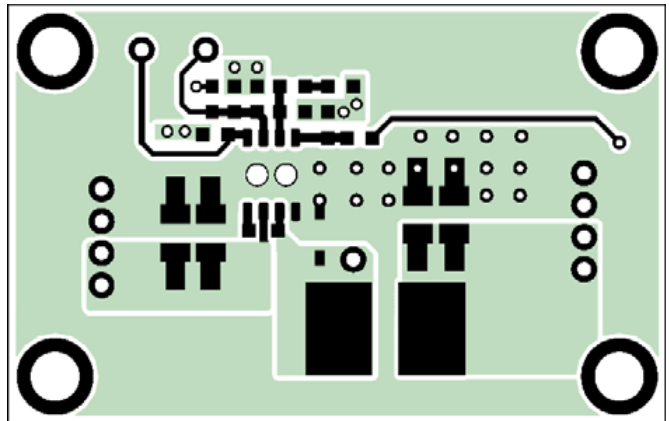

Figure 2—Top Layer

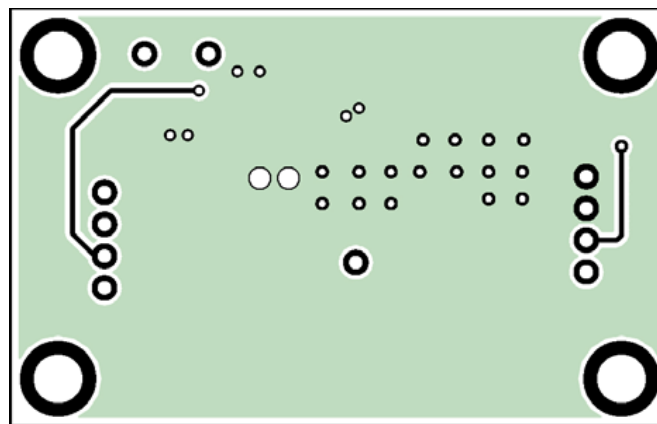

Figure 3—Bottom Layer

QUICK START GUIDE

The output voltage of this board is preset to 2.5V. The board is laid out to accommodate most commonly used inductors and output capacitors.

1. Connect the positive and negative ends of the load to the VOUT and GND pins, respectively.
2. Connect the input voltage ($4.3V \leq V_{IN} \leq 7V$) and input ground to the VIN and GND pins, respectively.
3. To turn on the MP9403, apply an enable voltage V_{EN} to the EN pin. Drive EN higher than 2.0V to turn on the MP9403 or lower than 1.1V to turn it off.
4. The output voltage V_{OUT} can be programmed by varying R1. Calculate the new value using the formula:

$$R1 = R2 \times \left(\frac{V_o}{V_{FB}} - 1 \right)$$

Where $V_{FB} = 0.8V$ and $R2 = 10k\Omega$.

For example, for $V_{OUT} = 2.5V$:

$$R1 = R2 \times \left(\frac{V_o}{V_{FB}} - 1 \right) = 10k\Omega \times \left(\frac{2.5}{0.8} - 1 \right) = 21.25k\Omega$$

for the closest standard 1% value.

RECOMMENDED COMPONENTS FOR STANDARD OUTPUT VOLOTAGES

This board is programmed for most standard output voltages. The following table lists recommended components for some standard output voltages.

Table 1—Recommended Components for Standard Output Voltages

Vout	R1 (1%)	R2 (1%)
0.8V	0	10kΩ
1.2V	4.99k Ω	10kΩ
1.8V	12.4k Ω	10kΩ
2.5V	21k Ω	10kΩ
3.3V	31.6k Ω	10kΩ

NOTICE: The information in this document is subject to change without notice. Users should warrant and guarantee that third party Intellectual Property rights are not infringed upon when integrating MPS products into any application. MPS will not assume any legal responsibility for any said applications.