

DESCRIPTION

The EV9143-J-00A is used for demonstrating the performance of MPS's MP9143, a low voltage high switching frequency step-down switcher with built in power MOSFETs. MP9143 provides up to 3A highly efficient output with constant-on-time control for fast loop response.

MP9143 is ideal for powering portable equipment that runs from a single cell Lithium-ion (Li+) Battery. The output voltage can be regulated as low as 0.6V.

High power efficiency over a wide load range is achieved by scaling down the switching frequency at light load to reduce the switching related loss by constant on time control. Short circuit and thermal shutdown provides reliable, fault-tolerant operation.

MP9143 is available in TSOT23-8 package.

ELECTRICAL SPECIFICATION

Parameter	Symbol	Value	Units
Input Voltage	V_{IN}	2.5– 5.5	V
Output Voltage	V_{OUT}	1.2	V
Output Current	I_{OUT}	3	A

FEATURES

- Wide 2.5V to 5.5V Operating Input Range
- Output Voltage as Low as 0.6V
- Up to 3A Output Current
- 40 μ A Quiescent Current
- 80m Ω and 40m Ω Internal Power MOSFET
- 1.2MHz Switching Frequency
- EN and Power Good for Power Sequencing
- Cycle-by-Cycle Over Current Protection
- Auto Discharge at Power Off
- Short Circuit Protection with Hiccup Mode
- Stable with Low ESR Ceramic Output Capacitors
- Available in a TSOT23-8 Package

APPLICATIONS

- Low Voltage I/O System Power
- Handheld/Battery-powered Systems
- Wireless/Networking Cards

All MPS parts are lead-free, halogen free, and adhere to the RoHS directive. For MPS green status, please visit MPS website under Quality Assurance. "MPS" and "The Future of Analog IC Technology" are Registered Trademarks of Monolithic Power Systems, Inc.

EV9143-J-00A EVALUATION BOARD



Board Number	MPS IC Number
EV9143-J-00A	MP9143DJ

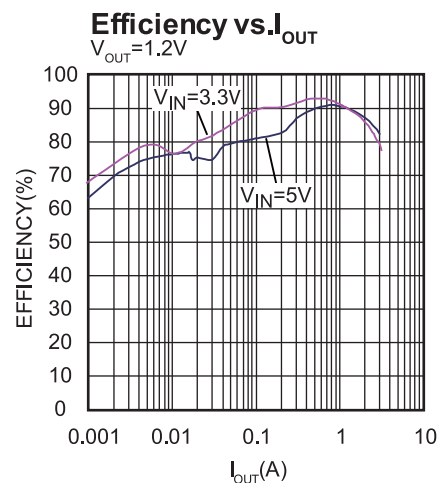

EVALUATION BOARD SCHEMATIC

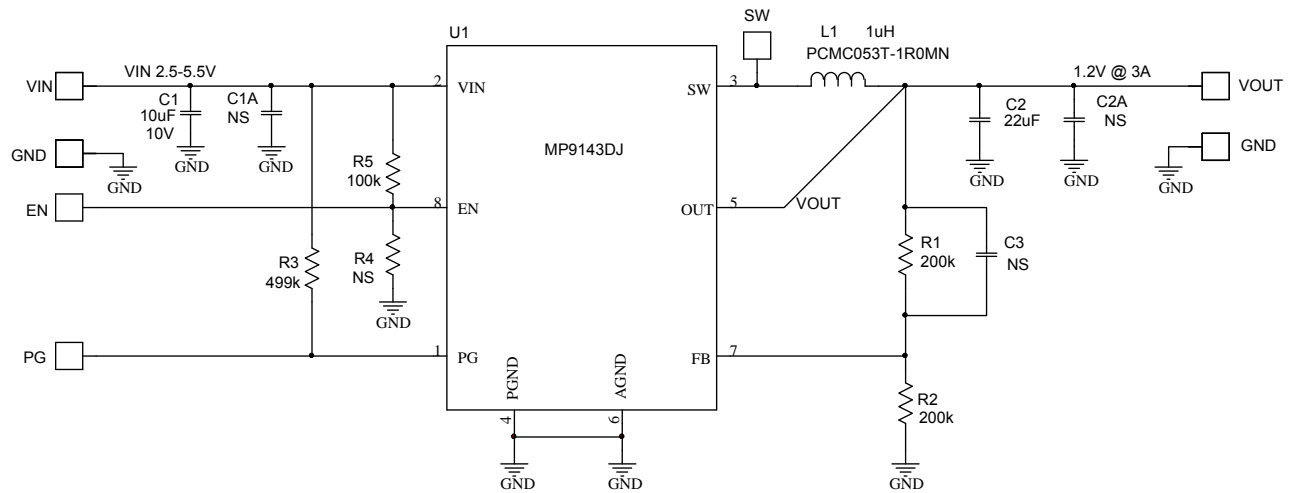

EV9143-J-00A BILL OF MATERIALS

Qty	RefDes	Value	Description	Package	Manufacturer	Manufacturer P/N
	C1A, C2A, C3	NS				
1	C1	10µF	Ceramic Cap., 10V,, X7R	1206	MuRata	GRM31CR71A106KA01L
1	C2	22µF	Ceramic Cap., 6.3V, X5R	1206	MuRata	GRM31CR60J226KE19
1	L1	1.0µH	Inductor, 6.4A, 8.8mΩ	7.3x6.8mm	TDK	RLF7030-1R0N6R4
		1.0µH	Inductor, 6.4A, 8.4mΩ	7.3x7.3mm	Würth	744777001
		1.0µH	Inductor, 6.4A, 8.8mΩ	5x5mm	Delta	PCMC053T-1R0MN
2	R1, R2	200k	Film Res., 1%	0603	Yageo	RC0603JR-07200KL
1	R3	499k	Film Res., 5%	0603	Yageo	RC0603JR-07499KL
1	R5	100k	Film Res., 5%	0603	Yageo	RC0603JR-07100KL
1	R4	NS				
1	U1	MP9143	Synchronous Step-Down switcher	TSOT23-8	MPS	MP9143DJ

TYPICAL PERFORMANCE CHARACTERISTICS

$V_{IN} = 5V$, $V_{OUT} = 1.2V$, $L = 1.0\mu H$, $C_{OUT} = 22\mu F$, $T_A = 25^\circ C$, unless otherwise noted

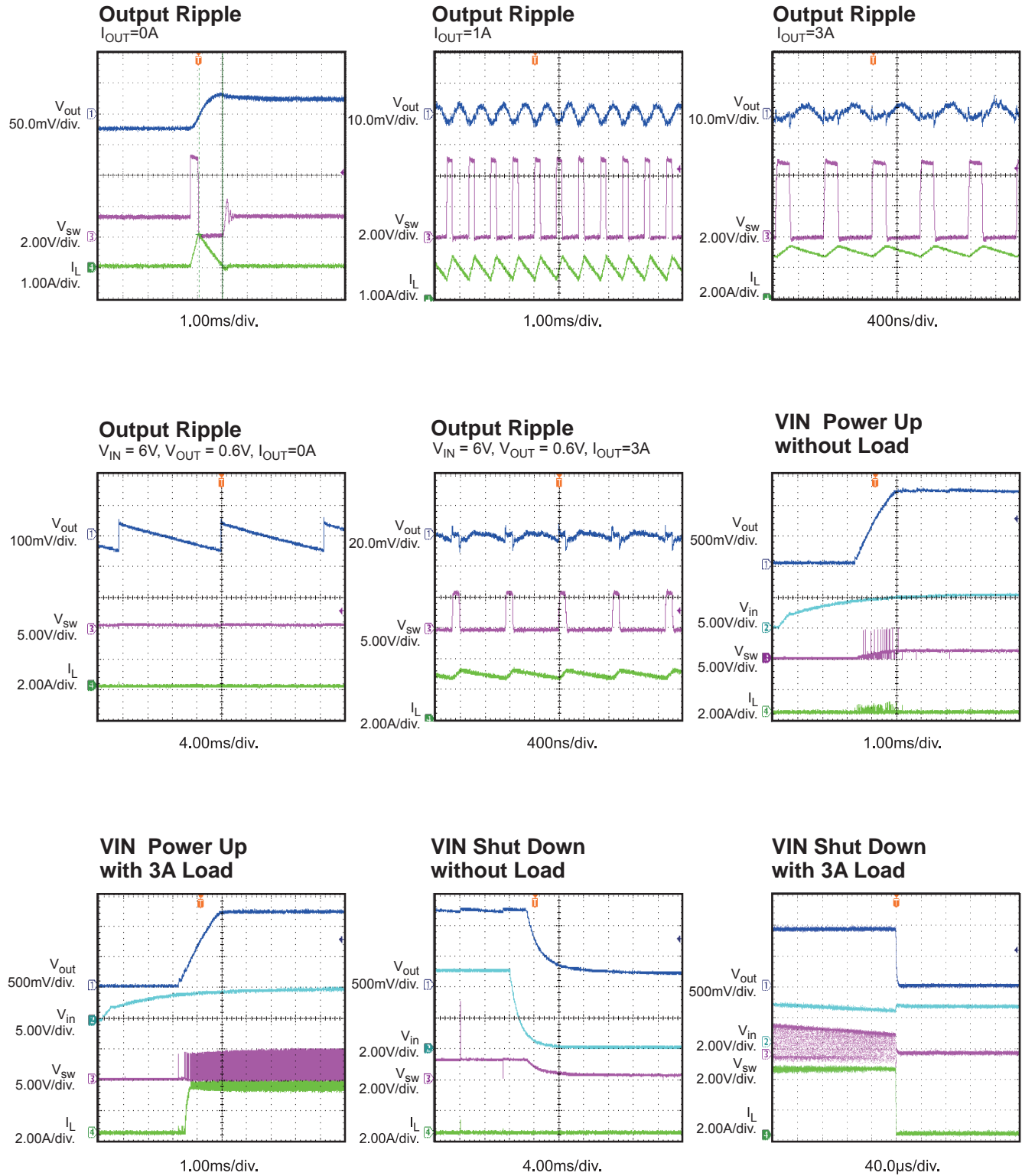

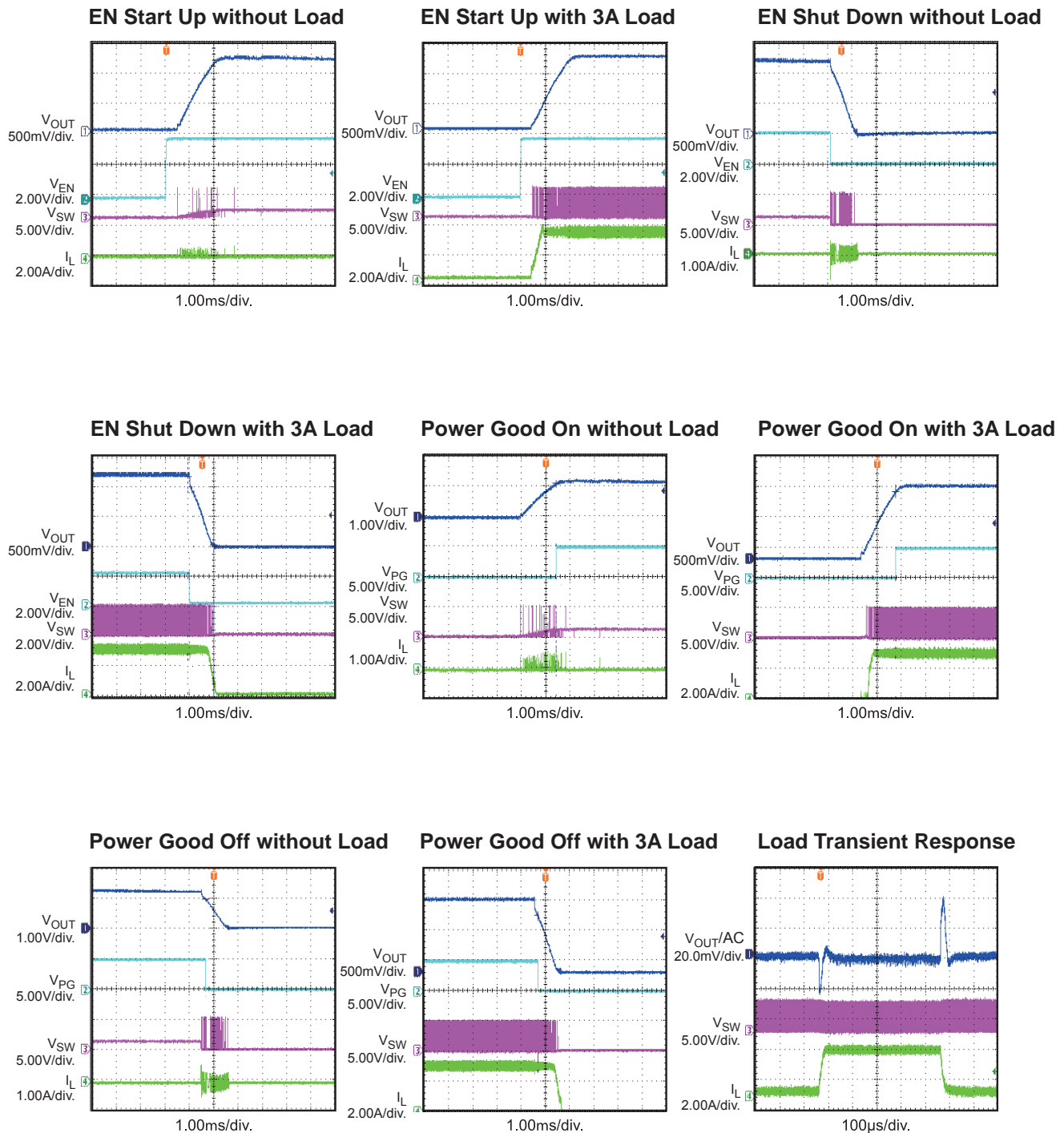
TYPICAL PERFORMANCE CHARACTERISTICS *(continued)*
 $V_{IN} = 5V$, $V_{OUT} = 1.2V$, $L = 1.0\mu H$, $C_{OUT} = 22\mu F$, $T_A = 25^\circ C$, unless otherwise noted

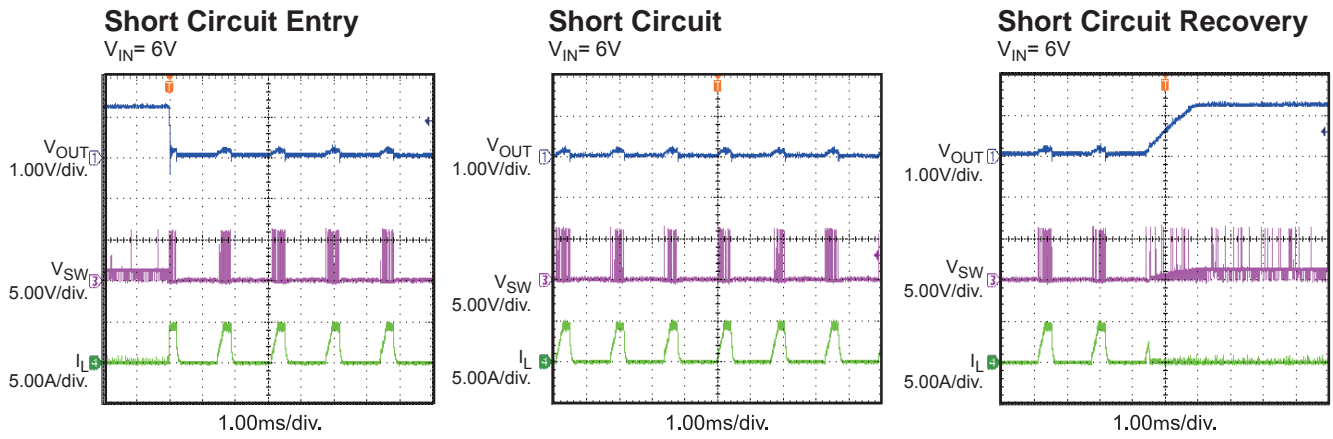
TYPICAL PERFORMANCE CHARACTERISTICS *(continued)*
 $V_{IN} = 5V$, $V_{OUT} = 1.2V$, $L = 1.0\mu H$, $C_{OUT} = 22\mu F$, $T_A = 25^\circ C$, unless otherwise noted.

PRINTED CIRCUIT BOARD LAYOUT

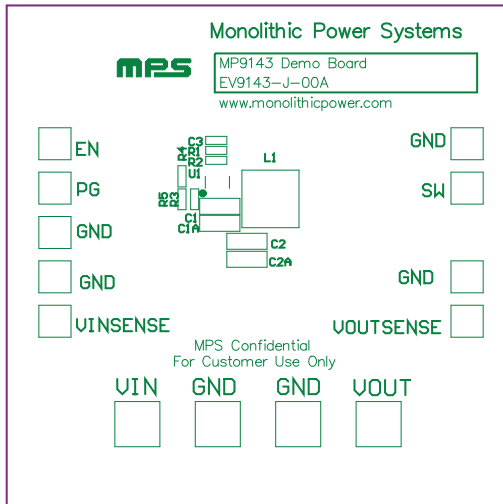

Figure 1—Top Silk Layer

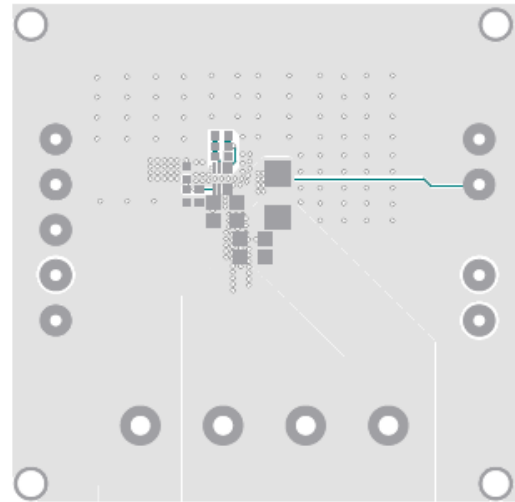

Figure 2—Top Layer

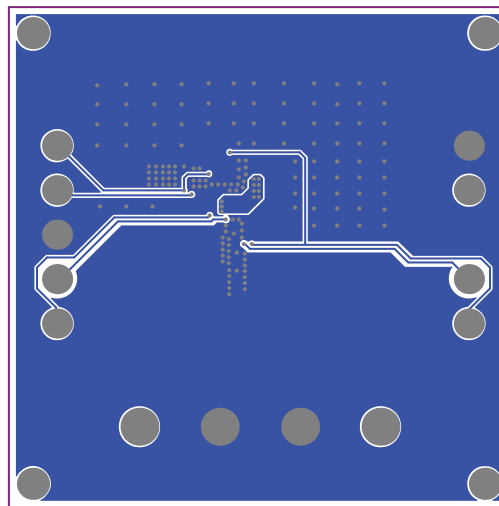

Figure 3— Bottom Layer

QUICK START GUIDE

1. Connect the positive and negative terminals of the load to the VOUT and GND pins, respectively.
2. Preset the power supply output between 2.5V and 5.5V, and then turn off the power supply.
3. Connect the positive and negative terminals of the power supply output to the VIN and GND pins, respectively.
4. Turn the power supply on. The board will automatically start up.
5. To use the Enable function, apply a digital input to the EN pin. Drive EN higher than 1.2V to turn on the regulator or less than 0.4V to turn it off.

LAYOUT RECOMMENDATION OF MP9143

Proper layout of the switching power supplies is very important, and sometimes critical to make it work properly. Especially, for the high switching converter, if the layout is not carefully done, the regulator could show poor line or load regulation, stability issues.

For MP9143, the high speed step-down regulator, the input capacitor should be placed as close as possible to the IC pins. As shown in Figure 4, the 0805 size ceramic capacitor (C1) is used, please make sure the two ends of the ceramic capacitor be directly connected to PIN2 (the Power Input Pin) and PIN 4 (the Power GND Pin).

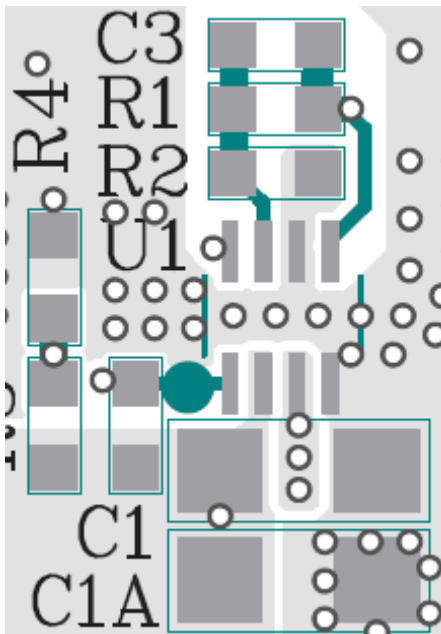

Figure 4— Two ends of Input decoupling Capacitor close to Pin 2 and Pin 4

NOTICE: The information in this document is subject to change without notice. Please contact MPS for current specifications. Users should warrant and guarantee that third party Intellectual Property rights are not infringed upon when integrating MPS products into any application. MPS will not assume any legal responsibility for any said applications.