

## DESCRIPTION

The EV8775EN-00A is an evaluation board for the MP8775EN, a monolithic synchronous buck regulator.

This EV board can deliver 5A continuous load current over an operating input voltage 5V to 23V. High efficiency power conversion is achieved through the use of synchronous rectification techniques.

Current mode control is implemented, which provides fast transient response and cycle-by-cycle current limiting.

This EV board can be turned on or shut down via a remote ON/OFF input that is referenced to ground. This input is compatible with popular logic devices.

## ELECTRICAL SPECIFICATIONS

Parameter	Symbol	Value	Units
Input Voltage	V <sub>IN</sub>	5 – 23	V
Output Voltage	V <sub>OUT</sub>	1.8	V
Output Current	I <sub>OUT</sub>	5	A

## FEATURES

- Wide 5V to 23V Operating Input Range
- 5A Output Current
- Low RDS(ON) Internal Power MOSFETs
- Proprietary Switching Loss Reduction Technique
- Fixed 500kHz Switching Frequency
- Internal Compensation
- OCP Protection and Thermal Shutdown
- Output Adjustable from 0.8V
- Available in SOIC8E Package

## APPLICATIONS

- Notebook Systems and I/O Power
- Networking Systems
- Digital Set Top Boxes
- Personal Video Recorders
- Flat Panel Television and Monitors
- Distributed Power Systems

"MPS" and "The Future of Analog IC Technology" are Registered Trademarks of Monolithic Power Systems, Inc.

## EV8775EN-00A EVALUATION BOARD



(L x W x H) 2.5" X 2.5" X 0.05"  
(6.35cm x 6.35cm x 1.3mm)

Board Number	MPS IC Number
EV8775EN-00A	MP8775EN

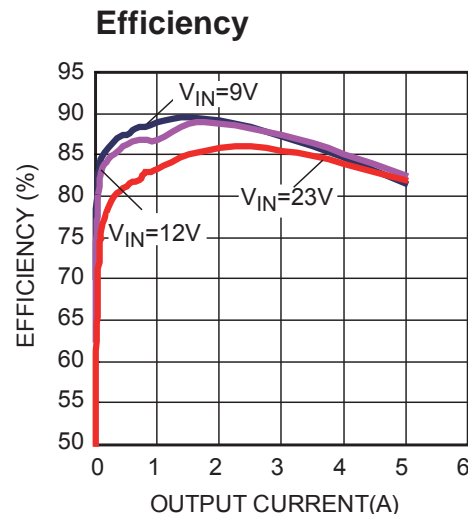

## EVALUATION BOARD SCHEMATIC

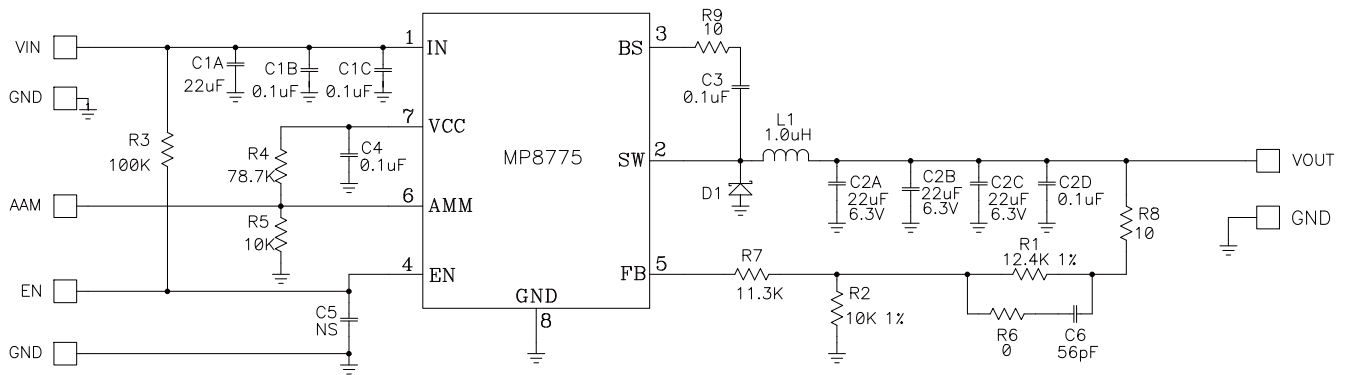

## EV8775EN-00A BILL OF MATERIALS

Qty	Ref	Value	Description	Package	Manufacturer	Part Number
1	C1A	22µF	Ceramic Cap., 25V, X7R	1210	muRata	GRM32ER71E226KE15L
3	C1B,C1C,C3	0.1µF	Ceramic Cap., 50V, X7R	0603	muRata	GRM188R71H104KA93D
3	C2A,C2B,C2C	22µF	Ceramic Cap., 10V, X7R	1210	muRata	GRM32ER71A226KE20L
2	C2D,C4	0.1µF	Ceramic Cap., 25V, X7R	0603	muRata	GRM188R71E104KA01D
1	C5	NS	Not Stuffed			
1	C6	56pF	Ceramic Cap., 50V, C0G	0603	TDK	C1608C0G1H560J
1	R1	12.4k	Film Res., 1%	0603	Yageo	RC0603FR-0712K4L
2	R2,R5	10k	Film Res., 1%	0603	Yageo	RC0603FR-0710KL
1	R7	11.3k	Film Res., 1%	0603	Yageo	RC0603FR-0711K3L
1	R3	100k	Film Res., 1%	0603	Yageo	RC0603FR-07100KL
1	R4	78.7k	Film Res., 1%	0603	Yageo	RC0603FR-0778K7L
1	R6	0	Film Res., 5%	0603	Yageo	RC0603JR-070RL
2	R8,R9	10	Film Res., 1%	0603	Yageo	RC0603FR-0710RL
1	D1	NS	Not Stuffed			
1	L1	1µH	1.72mΩ, DCR, 31.3A	SMD	TOKO	FDU1250C-1R0M
1	U1		Step-Down Converter	SOIC8E	MPS	MP8775EN

## PRINTED CIRCUIT BOARD LAYOUT

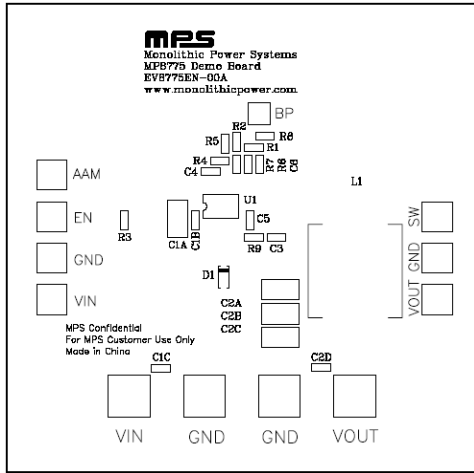

Figure 1—Top Silk Layer

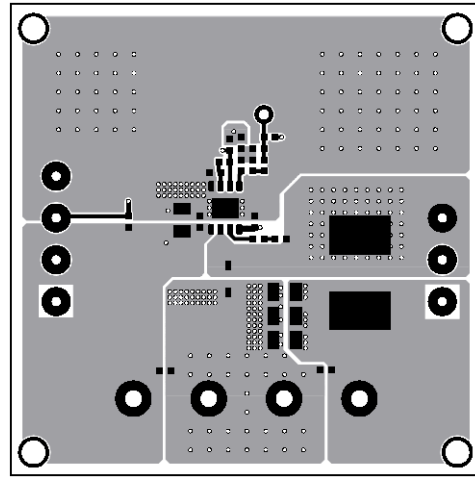

Figure 2—Top Layer

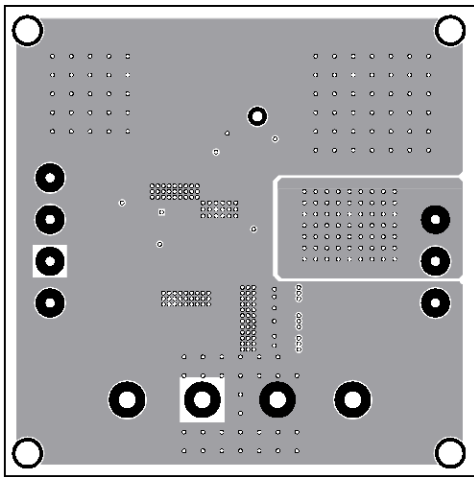

Figure 3—Inner Layer 1

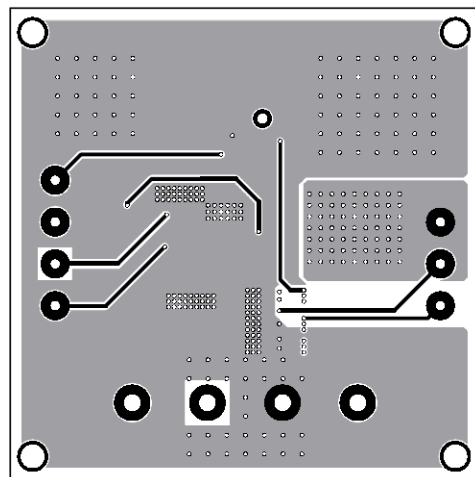

Figure 4—Inner Layer 2

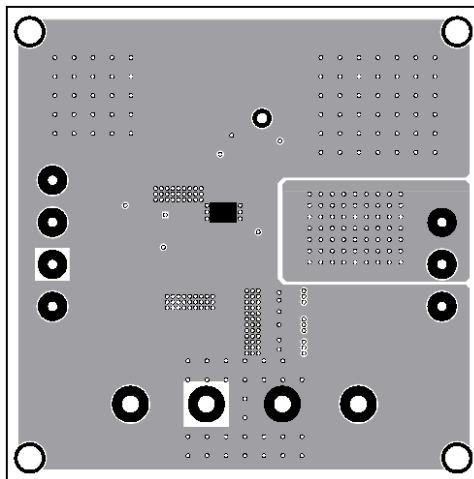

Figure 5—Bottom Layer

## QUICK START GUIDE

1. Connect the positive and negative terminals of the load to the VOUT and GND pins, respectively.
2. Preset the power supply output between 5V and 23V, and then turn off the power supply.
3. Connect the positive and negative terminals of the power supply output to the VIN and GND pins, respectively.
4. Turn the power supply on. The MP8775 will automatically startup.
5. To use the Enable function, apply a digital input to the EN pin. Drive EN higher than 2V to turn on the regulator or less than 0.4V to turn it off.
6. Use R1 and R2 to set the output voltage with  $V_{FB} = 0.8V$ . Follow the Application Information section in the device datasheet to select the proper value of R1, R2, inductor and output capacitor values when output voltage is changed.

**NOTICE:** The information in this document is subject to change without notice. Users should warrant and guarantee that third party Intellectual Property rights are not infringed upon when integrating MPS products into any application. MPS will not assume any legal responsibility for any said applications.