

DESCRIPTION

The MP8768 is a high frequency synchronous rectified step-down switch mode converter with a built in internal high side power MOSFET. It offers a very compact solution to achieve 8A continuous output current over a wide input supply range with excellent load and line regulation. The MP8768 has dual mode operation for higher efficiency over output current load range.

Current mode operation provides fast transient response and eases loop stabilization.

Full protection features include OCP and thermal shut down.

The MP8768 requires a minimum number of readily available standard external components and is available in a space saving 3mm x 4mm 14-pin QFN package.

FEATURES

- Wide 8V to 28V Operating Input Range
- 8A Output Current
- High Efficiency Dual Mode Operation
- Fixed 600KHz switching frequency
- Sync from 300KHz to 2MHz External Clock
- Internal Compensation
- OCP Protection and Thermal Shutdown
- Output Adjustable from 0.8V
- Available in 3mm x 4mm 14-pin QFN package

APPLICATIONS

- Point of Load Regulator in Distributed Power System
- Digital Set Top Boxes
- Personal Video Recorders
- Broadband Communications
- Flat Panel Television and Monitors

"MPS" and "The Future of Analog IC Technology" are Registered Trademarks of Monolithic Power Systems, Inc.

ELECTRICAL SPECIFICATIONS

Parameter	Symbol	Value	Units
Input Voltage	V_{IN}	8 – 28	V
Output Voltage	V_{OUT}	3.3	V
Output Current	I_{OUT}	8	A

EV8768DL-00A EVALUATION BOARD



Board Number	MPS IC Number
EV8768DL-00A	MP8768

Efficiency

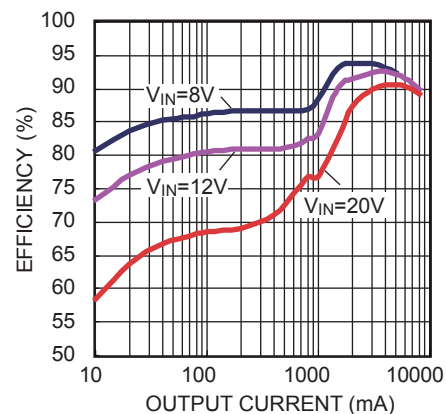

EVALUATION BOARD SCHEMATIC

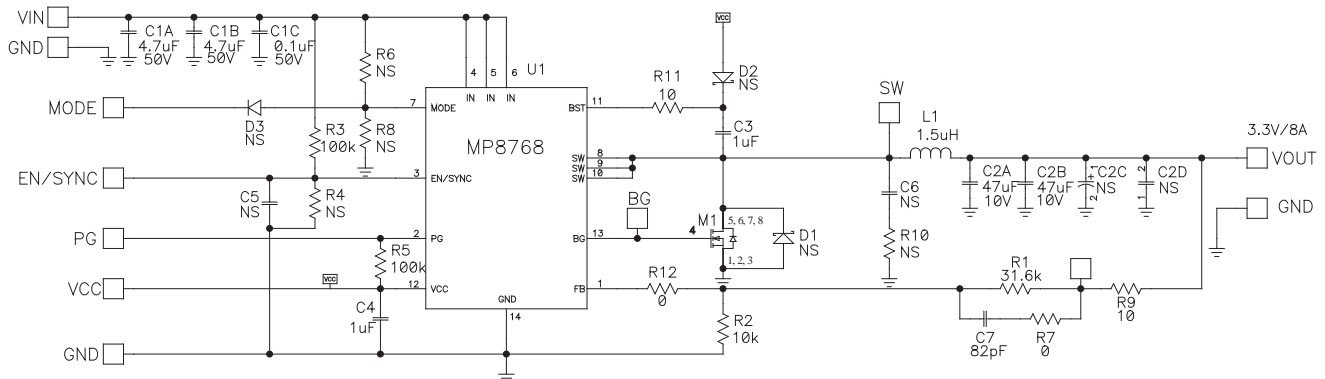

EV8768DL-00A BILL OF MATERIALS

Qty	Ref	Value	Description	Package	Manufacturer	Manufacturer P/N
2	C1A, C1B	4.7uF	Ceramic Cap, 50V, X7R	1210	Murata	GRM32ER71H475KA88L
1	C1C	0.1uF	Ceramic Cap, 50V, X7R	0603	Murata	GRM188R71H104KA93D
2	C2A, C2B	47µF	Ceramic Cap, 10V, X5R	1210	Murata	GRM32ER61A476KE20L
4	C2C, C2D, C5, C6	NS	Not Stuffed			
2	C3, C4	1µF	Ceramic Cap, 16V, X7R	0603	Murata	GRM188R71C105KA12D
1	C7	82pF	Ceramic Cap, 50V, COG	0603	Murata	GRM1885C1H820JA01D
1	R1	31.6k	Film Res., 1%	0603	Yageo	RC0603FR-0731K6L
1	R2	10k	Film Res., 1%	0603	Yageo	RC0603FR-0710KL
2	R3, R5	100k	Film Res., 5%	0603	Any	
4	R4, R6, R8, R10	NS	Not Stuffed			
2	R7, R12	0	Film Res., 5%	0603	Any	
2	R9, R11	10	Film Res., 5%	0603	Any	
1	L1	1.5uH	10mΩ DCR, 14A	SMD	Würth	744311150
		1.4uH	3.5mΩ DCR, 15A	SMD	Toko	D128C-#931BS-1R4M
1	M1		MOSFET, N-CH, 30V, 11.5mΩ	SO8	Fairchild	FDS6670AS
3	D1, D2, D3	NS	Not Stuffed			
1	U1		Step-Down Converter	QFN14	MPS	MP8768DL

PRINTED CIRCUIT BOARD LAYOUT

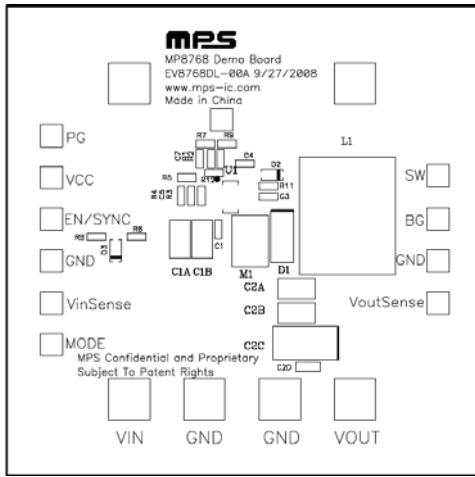

Figure 1—Top Silk Layer

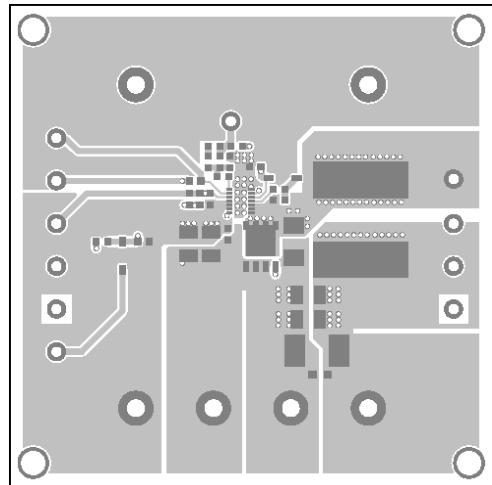

Figure 2—Top Layer

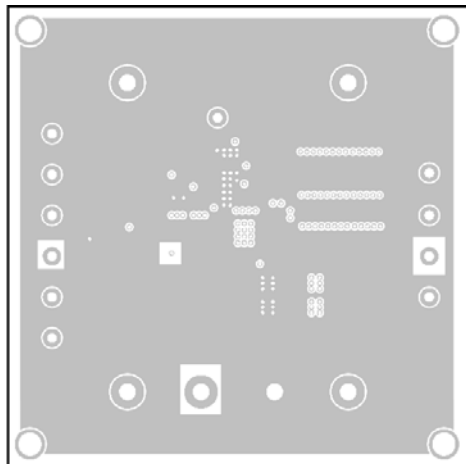

Figure 3—Inner Layer 1

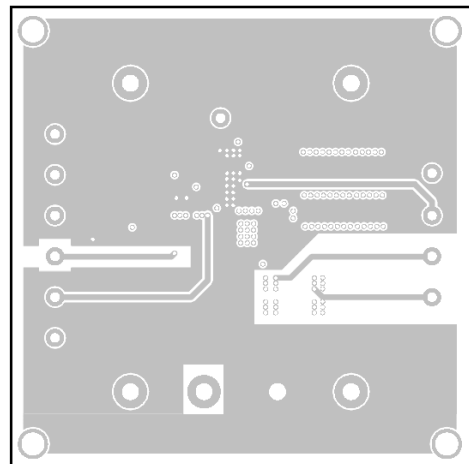

Figure 4—Inner Layer 2

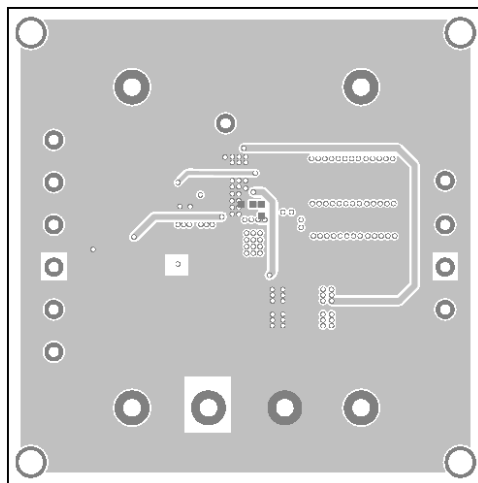

Figure 5—Bottom Layer

QUICK START GUIDE

1. Connect the positive and negative terminals of the load to the VOUT and GND pins, respectively.
2. Preset the power supply output to between 8V and 28V, then turn off the power supply.
3. Connect the positive and negative terminals of the power supply output to the VIN and GND pins, respectively.
4. Turn the power supply on. The board will automatically startup.
5. To use the Enable function, apply a digital input to the EN pin. Drive EN higher than 2V to turn on the regulator or less than 0.4V to turn it off.
6. Apply up to 2MHz frequency logic level clock signal to the EN pin to synchronize the device to an external clock. The duty cycle is not critical.

NOTICE: The information in this document is subject to change without notice. Users should warrant and guarantee that third party Intellectual Property rights are not infringed upon when integrating MPS products into any application. MPS will not assume any legal responsibility for any said applications.