

### DESCRIPTION

The EV8676DN-00A evaluation board is a fully assembled and tested PCB that demonstrates the performance of MP8676, a monolithic step-down switch mode regulator.

The EVB achieves 4.5A continuous output current over a wide input supply range from 4.5V to 42V. The MP8676 switches at 420kHz and is synchronizable up to >1.5MHz external clock.

Current mode operation provides fast transient response and eases loop stabilization.

Fault condition protection includes cycle-by-cycle current limiting and thermal shutdown.

This device, available in an 8-pin SOIC package with exposed pad, provides a very compact system solution with minimal reliance on external components.

### ELECTRICAL SPECIFICATIONS

Parameter	Symbol	Value	Units
Input Voltage	$V_{IN}$	4.5 – 42	V
Output Voltage	$V_{OUT}$	3.3	V
Output Current	$I_{OUT}$	4.5	A

### FEATURES

- Wide 4.5V to 42V Operating Input Range
- 4.5A Continuous Output Current
- Fixed 420kHz Frequency
- Synchronizable up to 1.5MHz
- 3.3V Rating Output Voltage
- Stable with Low ESR Output Ceramic Capacitors
- Fully Assembled and Tested

### APPLICATIONS

- Digital Set Top Boxes
- Personal Video Recorders
- Broadband Communications
- Flat Panel Television and Monitors

"MPS" and "The Future of Analog IC Technology" are Registered Trademarks of Monolithic Power Systems, Inc.

## EV8676DN-00A EVALUATION BOARD



(L x W x H) 2.2" x 2.0" x 0.5"  
(5.6cm x 5.0cm x 1.2cm)

Board Number	MPS IC Number
EV8676DN-00A	MP8676DN

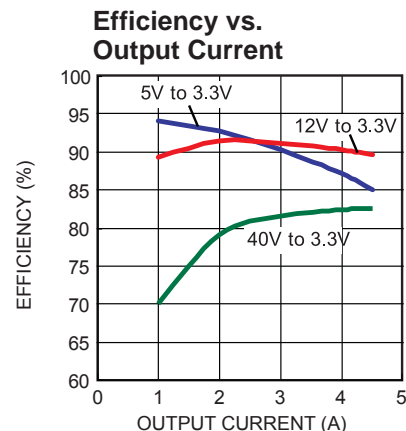

## EVALUATION BOARD SCHEMATIC

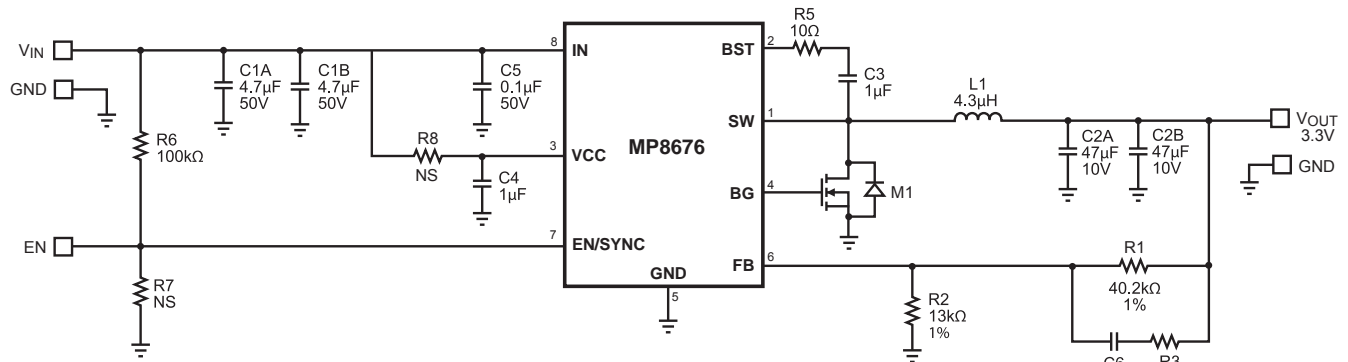

## EV8676DN-00A BILL OF MATERIALS

Qty	Ref	Value	Description	Package	Manufacturer	Part Number
2	C1A, C1B	4.7μF	Ceramic Cap, 50V, X7R	1210	Murata	GRM32ER71H475KA88L
2	C2A, C2B	47μF	Ceramic Cap, 10V, X5R	1210	Murata	GRM32ER61A476KE20L
2	C3, C4	1μF	Ceramic Cap, 16V, X7R	603	Any	
1	C5	0.1μF	Ceramic Cap, 50V, X7R	805	Any	
1	C6	100pF	Ceramic Cap, 50V, X7R	603	Any	
1	R1	40.2kΩ	Film Res., 1%	603	Any	
1	R2	13kΩ	Film Res., 1%	603	Any	
1	R3	0Ω	Film Res., 5%	603	Any	
1	R5	10Ω	Film Res., 5%	603	Any	
1	R6	100kΩ	Film Res., 5%	603	Any	
2	R7, R8	NS	Not Stuffed			
1	L1	4.3μH	Inductor, 7.5A	SMD	TOKO	D106C-962BS-4R3M
1	M1		MOSFET, N-CH 60V	SO-8	Vishay	Si4470EY
				Powerpak SO-8		Si7370DP
1	U1		Step-Down converter	SO-8	MPS	MP8676DN

## PRINTED CIRCUIT BOARD LAYOUT

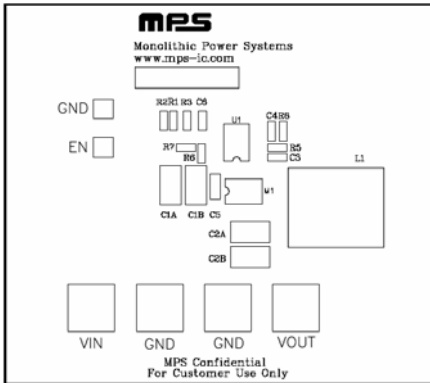

Figure 1—Top Silk Layer

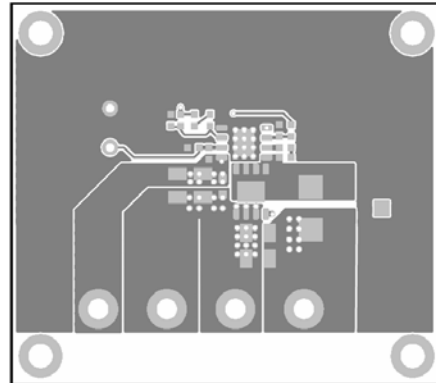

Figure 2—Top Layer

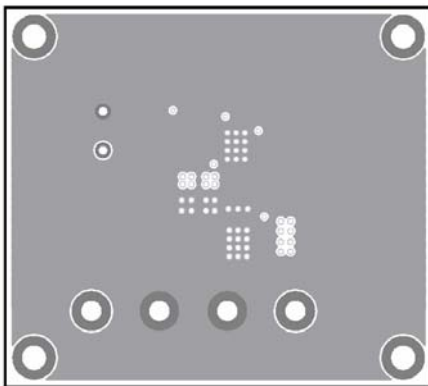

Figure 3—Inner Layer 1

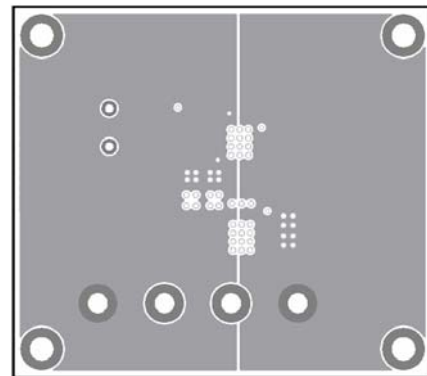

Figure 4—Inner Layer 2

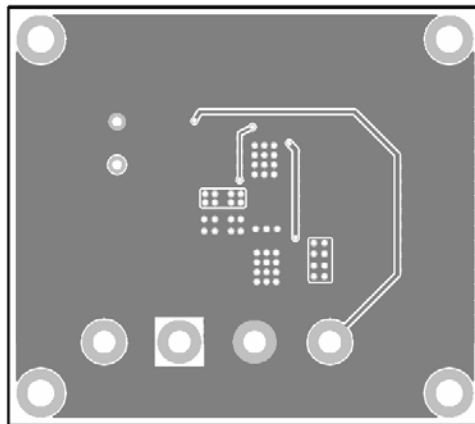

Figure 5—Bottom Layer

## QUICK START GUIDE

1. Connect the positive and negative terminals of the load to VOUT and GND pins, respectively.
2. Preset the power supply output to 4.5V – 42V and turn off the power supply.
3. Connect the positive and negative terminals of the power supply output to the VIN and GND pins, respectively.
4. Turn the power supply on. The board will automatically startup.
5. To use the Enable function, apply a digital input to EN pin. Drive EN higher than 2V to turn on the regulator, drive EN less than 0.4V to turn it off.
6. Apply up to 1.5MHz frequency logic level clock signal to the EN pin to synchronize the device to an external clock. The duty cycle is not critical.

**NOTICE:** The information in this document is subject to change without notice. Users should warrant and guarantee that third party Intellectual Property rights are not infringed upon when integrating MPS products into any application. MPS will not assume any legal responsibility for any said applications.