

DESCRIPTION

The EV8652DL-00A is an evaluation board for the MP8652, a 400KHz step-down regulator.

An integrated 18mΩ power MOSFETS provides 15A continuous load current over a wide operating input voltage of 4.5V to 14V.

Current mode control provides fast transient response and eases loop stabilization.

This device is available in a 20-pin 3mm x 4mm QFN package.

ELECTRICAL SPECIFICATIONS

Parameter	Symbol	Value	Units
Input Voltage	V _{IN}	4.5 – 14	V
Output Voltage	V _{OUT}	1.2	V
Output Current	I _{OUT}	15	A

FEATURES

- 15A Output Current
- Wide 4.5V to 14V Operating Input Range
- Synchronizable to > 1MHz External Clock
- Adjustable Output from 0.8V to 12V
- Fully Assembled and Tested

APPLICATIONS

- Blade Servers
- Digital Set-top Box
- Personal Video Recorders
- Broadband Communications
- Flat Panel Television and Monitors
- Distributed Power Systems

"MPS" and "The Future of Analog IC Technology" are Registered Trademarks of Monolithic Power Systems, Inc.

EV8652DL-00A EVALUATION BOARD

TBD

(L x W x H) 2.9" x 2.9" x 0.5"
(7.5cm x 7.5cm x 1.2cm)

Board Number	MPS IC Number
EV8652DL-00A	MP8652DL

Efficiency vs. Output Current

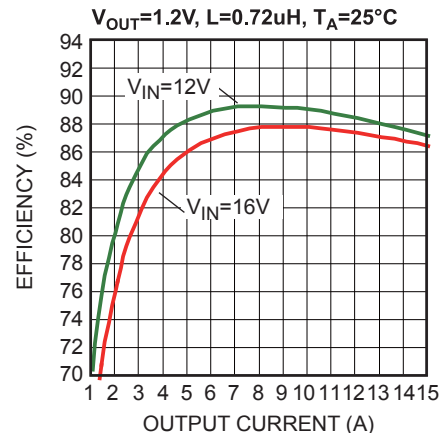

EVALUATION BOARD SCHEMATIC

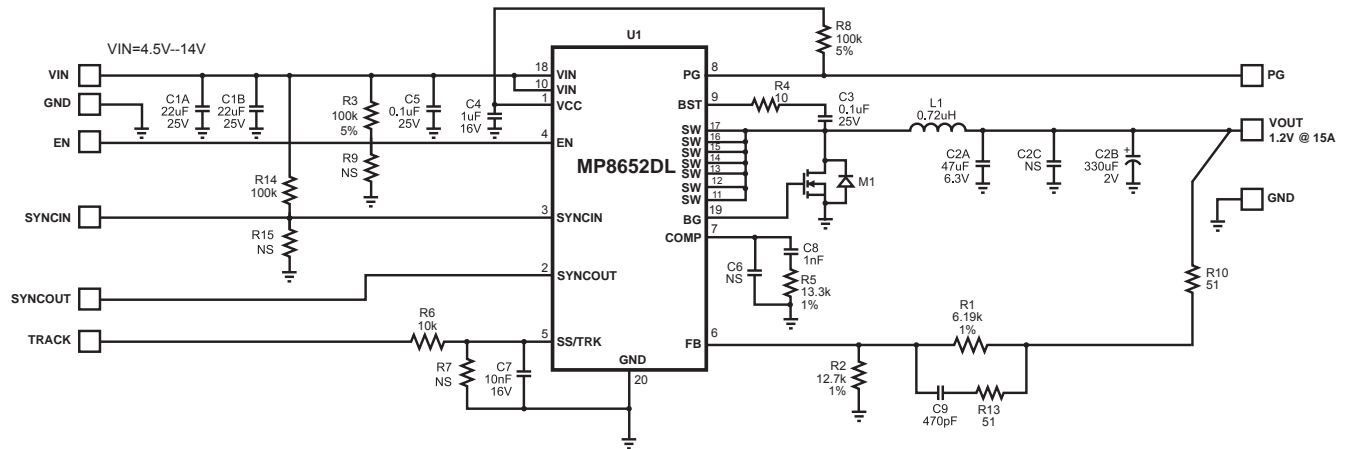

EV8652DL-00A BILL OF MATERIALS

Qty	Ref	Value	Description	Package	Manufacturer	Part Number
1	Label		EV8652DL-00A			
2	C1A,C1B	22uF	Ceramic Cap., 25V, X7R	1210	MuRata	GRM32ER71E226KA
1	C2A	47uF	Ceramic Cap. 6.3V, X5R	1210	MuRata	GRM32ER70J476KE20L
1	C2B	330uF	2V PosCap E.S.R=6mohm	D2E	SANYO	2TPF330M6
	C2C	NS				
2	C3,C5	0.1uF	Ceramic Cap. 25V, X7R	0603	MuRata	GRM188R71E104KA
1	C4	1uF	Ceramic Cap. 16V, X7R	0603	MuRata	GRM188R71C105KA
1	C6	NS	Ceramic Cap., 16V, X7R	0603	MuRata	GRM188R71C102KA
1	C7	10nF	Ceramic Cap., 16V, X7R	0603	MuRata	GRM188R71C103KA
1	C8	1nF	Ceramic Cap., 16V, X7R	0603	MuRata	GRM188R71C102KA
1	C9	470pF	Ceramic Cap., 16V, X7R	0603	MuRata	GRM188R71C471KA
1	R1	6.19K	Film Res., 1%	0603	Yageo	9C06031A6191FKHFT
1	R2	12.7K	Film Res., 1%	0603	Yageo	9C06031A1272FKHFT
3	R3,R8,R14	100K	Film Res., 5%	0603	Yageo	RC0603JR-07100KL
1	R4	10Ω	Film Res., 5%	0603	Yageo	RC0603JR-0710RL
1	R5	13.3K	Film Res., 1%	0603	Yageo	9C06031A1332FKHFT
1	R6	10K	Film Res., 5%	0603	Yageo	RC0603JR-0710KL
	R7,R9,R15	NS				
2	R10,R13	51Ω	Film Res., 5%	0603	Yageo	RC0603JR-0751RL
1	L1	0.72uH	Inductor Isa=35A, DCR=1.35Ω	SML We- 10x10x5 mm	Wurth	we-744325072
1	M1	MOSFET	30V N-FET RDSON=3m, ID=60A	Power- SO-8	VISHAY	Si7658ADP
1	U1		Step-Down Regulator	QFN20/3 X4MM	MPS	MP8652DL

PRINTED CIRCUIT BOARD LAYOUT

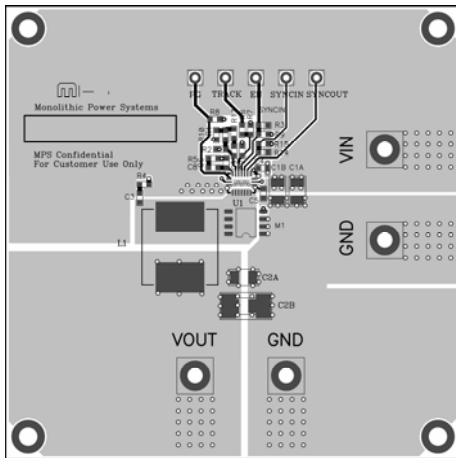

Figure 1—Top and Top Silk Layer

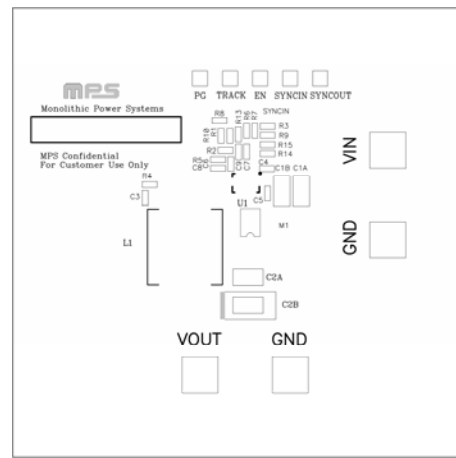

Figure 2—Top Silk Layer

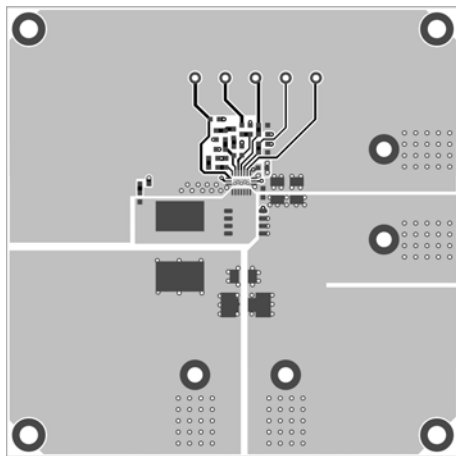

Figure 3—Top Layer

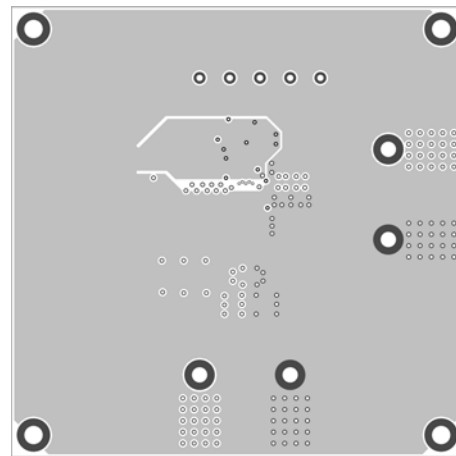

Figure 4—Inner Layer 1

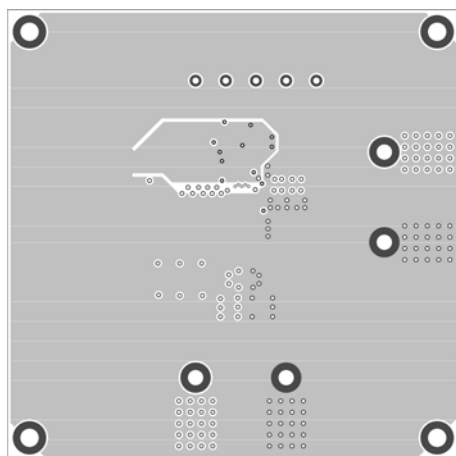

Figure 5—Inner Layer 2

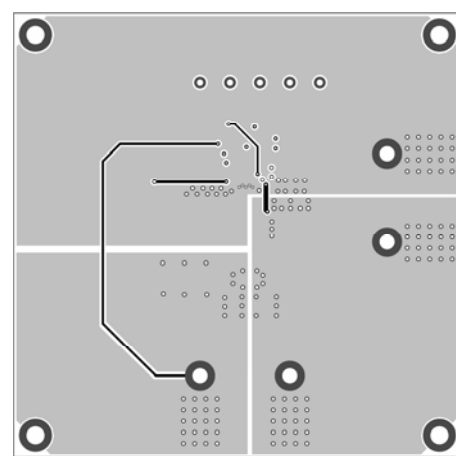

Figure 6—Bottom Layer

QUICK START GUIDE

1. Connect the positive and negative terminals of the load to the VOUT and GND pins, respectively.
2. Preset the power supply output to between 4.5V and 14V, then turn off the power supply.
3. Connect the positive and negative terminals of the power supply output to the VIN and GND pins, respectively.
4. Turn the power supply on. The board will automatically startup.
5. To use the Enable function, apply a digital input to the EN pin. Drive EN higher than 1.2V to turn on the regulator or less than 0.4V to turn it off.
6. Apply up to 1MHz frequency logic level clock signal to the EN pin to synchronize the device to an external clock. The duty cycle is not critical.

NOTICE: The information in this document is subject to change without notice. Users should warrant and guarantee that third party Intellectual Property rights are not infringed upon when integrating MPS products into any application. MPS will not assume any legal responsibility for any said applications.