

DESCRIPTION

The MP8620 is a fully integrated step-down switch mode converter with built-in internal power MOSFETs. It achieves 25A continuous output current over a wide input supply range with excellent load and line regulation. Average current mode control scheme is employed in MP8620. It provides a reliable operation at low duty cycle in a noisy environment.

This EV board can be turned on or shut down via a remote ON/OFF input that is referenced to ground. This input is compatible with popular logic devices.

ELECTRICAL SPECIFICATIONS

Parameter	Symbol	Value	Units
Input Voltage	V_{IN}	8 – 15	V
Output Voltage	V_{OUT}	1.2	V
Output Current	I_{OUT}	25	A
Switch Frequency	f_{SW}	300	kHz

FEATURES

- Wide 8V to 15V Operating Input Range
- 25A Output Current
- 3mΩ/12mΩ Internal Power MOSFET Switches Deliver up to 95% Efficiency
- Synch from 300kHz to 1.5MHz External Clock
- Synch Output to Drive Another Regulator in 90°, 120°, 180° Phase-Shift Operation
- Feedback Voltage Accuracy: 1.0%
- Programmable Soft-Start
- Startup Tracking
- EN and Power Good for Power Sequencing
- Cycle-by-Cycle Over Current Protection
- Thermal Shutdown
- Output Adjustable from 0.8V to 3.3V
- Stable with Low ESR Output Ceramic Capacitors
- Available in a 6mmx6mm QFN Package

APPLICATIONS

- Distributed Power Systems
- Pre-Regulator for Linear Regulators
- Compact DC-DC Regulator for PCB Space Limited Platforms

"MPS" and "The Future of Analog IC Technology" are Registered Trademarks of Monolithic Power Systems, Inc.

EV8620DQK-01A EVALUATION BOARD



Board Number	MPS IC Number
EV8620DQK-01A	MP8620 R3

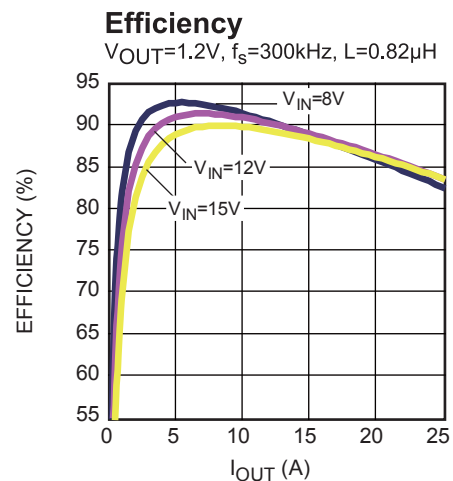

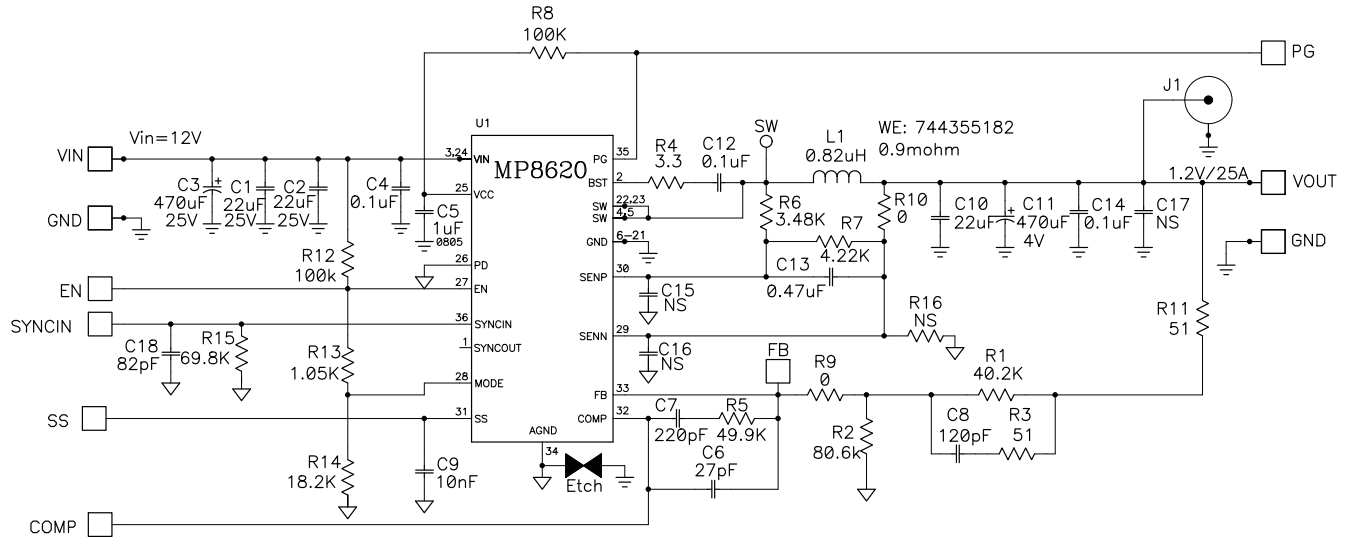
EVALUATION BOARD SCHEMATIC

EV8620DQK-01A BILL OF MATERIALS

Qty	Ref	Value	Description	Package	Manufacturer	Manufacturer P/N
2	C1, C2	22 μ F	Ceramic Cap, 25V, X7R	1210	MuRata	GRM32ER71E226KA
1	C3	470 μ F	Elec. Cap, 25V	10X12.5X5	Panasonic	ECA-1EM471B
3	C4,C12, C14	0.1 μ F	Ceramic Cap, 25V, X7R	SM0603	MuRata	GRM188R71E104KA
1	C5	1 μ F	Ceramic Cap, 25V, X5R	SM0805	MuRata	GRM216R61E105KA12D
1	C6	27pF	Ceramic Cap, 25V, C0G	SM0603	MuRata	GRM1885C1H270JA01D
1	C7	220pF	Ceramic Cap, 25V, X7R	SM0603	MuRata	GRM188R71H221KA01D
1	C8	120pF	Ceramic Cap, 25V, X7R	SM0603	MuRata	GRM188R71H121KA01D
1	C9	10nF	Ceramic Cap, 25V, X7R	SM0603	MuRata	GRM188R71C103KA
1	C10	22 μ F	Ceramic Cap. 6.3V, X5R	1206	MuRata	GCM31CR70J226KE23L
1	C11	470 μ F	POSCAP, 4V, 12mohm	D3L	MuRata	4TPE470MCL
1	C13	0.47 μ F	Ceramic Cap, 25V, X7R	SM0603	MuRata	GRM188R71E474KA12D
	C15, C16,C17	NS		SM0603		
1	C18	82pF	Ceramic Cap, 25V, C0G	SM0603	MuRata	GRM1885C1H820JA01D
1	R1	40.2k Ω	Film Res, 1%	SM0603	Yageo	RC0603FR-0740K2L
1	R2	80.6k Ω	Film Res, 1%	SM0603	Yageo	RC0603FR-0780K6L
2	R3, R11	51 Ω	Film Res, 5%	SM0603	Yageo	RC0603JR-0751RL
1	R4	3.3 Ω	Film Res, 5%	SM0603	Yageo	RC0603JR-073R3L
1	R5	49.9k Ω	Film Res, 1%	SM0603	Yageo	RC0603FR-0749K9L
1	R6	3.48k Ω	Film Res, 1%	SM0603	Yageo	RC0603FR-073K48L
1	R7	4.22k Ω	Film Res, 1%	SM0603	Yageo	RC0603FR-074K22L
2	R8,R12	100k Ω	Film Res, 5%	SM0603	Yageo	RC0603JR-07100KL
2	R9,R10	0 Ω	Film Res, 5%	SM0603	Yageo	RC0603JR-070R0L
1	R13	1.05k	Film Res, 1%	SM0603	Yageo	RC0603FR-071K05L
1	R14	18.2k	Film Res, 1%	SM0603	Yageo	RC0603FR-0718k2L
1	R15	69.8k	Film Res, 1%	SM0603	Yageo	RC0603FR-0769K8L
	R16	NS		SM0603		
1	J1	NS		SMA		
1	L1	0.82 μ H	Inductor DCR=0.9m Ω	SMD	Würth	We-744355182
9	Vinsense	Test Point	TP1MM		HZ	China
4	VOUT,G ND,GND, VIN	Power Post	TP2MM	W200D100	HZ	China
1	U1		DC-DC Converter	6X6 QFN	MPS	MP8620DQK R3

PRINTED CIRCUIT BOARD LAYOUT

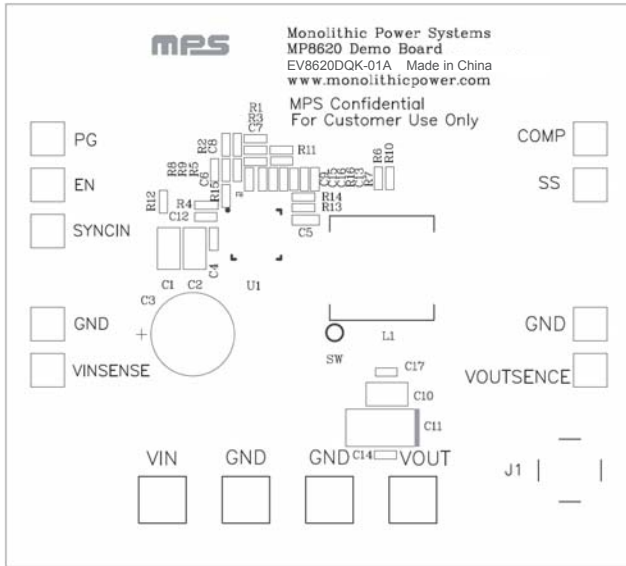

Figure 1—Top Silk Layer

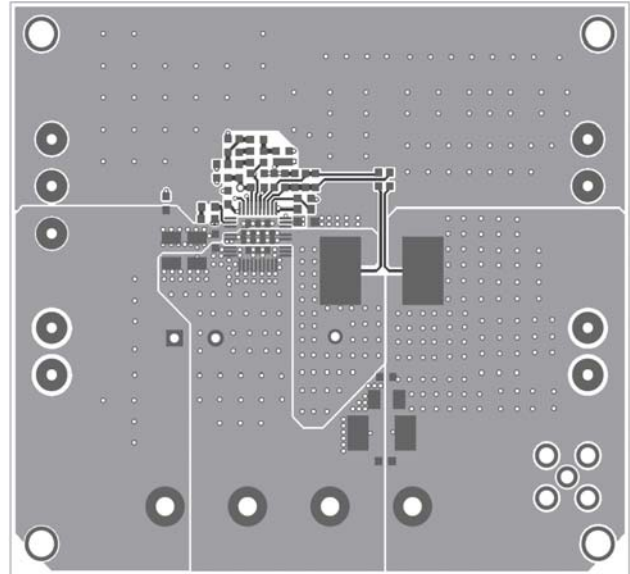

Figure 2—Top Layer

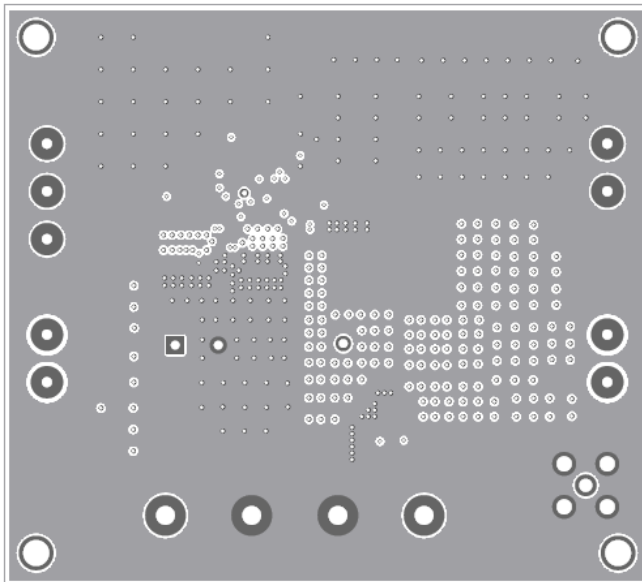

Figure 3—Inner Layer 1

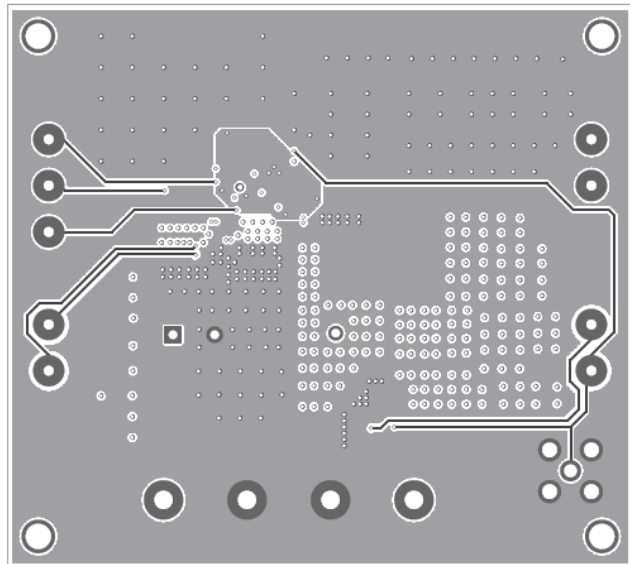

Figure 4— Inner Layer

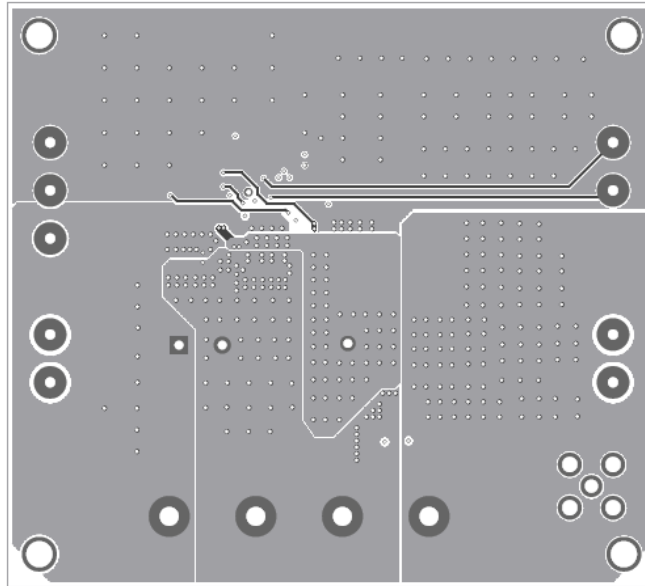

Figure 5—Bottom Layer

QUICK START GUIDE

1. Connect the positive and negative terminals of the load to the VOUT and GND pins, respectively.
2. Preset the power supply output between 8V and 16V, and then turn off the power supply.
3. Connect the positive and negative terminals of the power supply output to the VIN and GND pins, respectively.
4. Turn the power supply on. The MP8620 will automatically startup.
5. To use the Enable function, apply a digital input to the EN pin. Drive EN higher than 2V to turn on the regulator or less than 0.4V to turn it off.
6. Use R1 and R2 to set the output voltage with $V_{FB} = 0.8V$. Follow the Application Information section in the device datasheet to select the proper value of R1, R2, inductor and output capacitor values when output voltage is changed.

NOTICE: The information in this document is subject to change without notice. Users should warrant and guarantee that third party Intellectual Property rights are not infringed upon when integrating MPS products into any application. MPS will not assume any legal responsibility for any said applications.