

DESCRIPTION

The EV8606DL-00A is a fully integrated high frequency synchronous rectified step-down switch mode converter. It offers a very compact solution to achieve 6A continuous output current over a wide input supply range with excellent load and line regulation. The MP8606 operates at high efficiency over a wide output current load range.

Constant-On-Time (COT) control mode provides fast transient response and eases loop stabilization.

Full protection features include OCP, OVP, UVP and thermal shut down.

The EV8606DL-00A requires a minimum number of readily available standard external components and is available in a space saving 3mm x 4mm 20-pin QFN package.

ELECTRICAL SPECIFICATIONS

Parameter	Symbol	Value	Units
Input Voltage Range	V _{IN}	2.9-6	V
Output Voltage	V _{OUT}	1	V
Load Max	I _{OUT}	6	A

FEATURES

- Wide 2.9V to 6V Operating Input Range
- 6A Output Current
- Low R_{DS(ON)} Internal Power MOSFETs
- Proprietary Switching Loss Reduction Technique
- 1% Reference Voltage
- Soft Shutdown
- Programmable Switching Frequency
- OCP, OVP, UVP Protection and Thermal Shutdown
- HICCUP during OCP/SCP
- Output Adjustable from 0.65V to 5.5V
- Available in 20-pin QFN3x4 Package

APPLICATIONS

- Notebook Systems and I/O Power
- Networking Systems
- Digital Set Top Boxes
- Personal Video Recorders
- Flat Panel Television and Monitors
- Distributed Power Systems

All MPS parts are lead-free and adhere to the RoHS directive. For MPS green status, please visit MPS website under Products, Quality Assurance page.

"MPS" and "The Future of Analog IC Technology" are registered trademarks of Monolithic Power Systems, Inc.

EV8606DL-00A EVALUATION BOARD



(L x W x H) 2.54" X 2.54" X 0.06"
(63.5mm x 63.5mm x 1.6mm)

Board Number	MPS IC Number
EV8606DL-00A	MP8606DL

EVALUATION BOARD SCHEMATIC

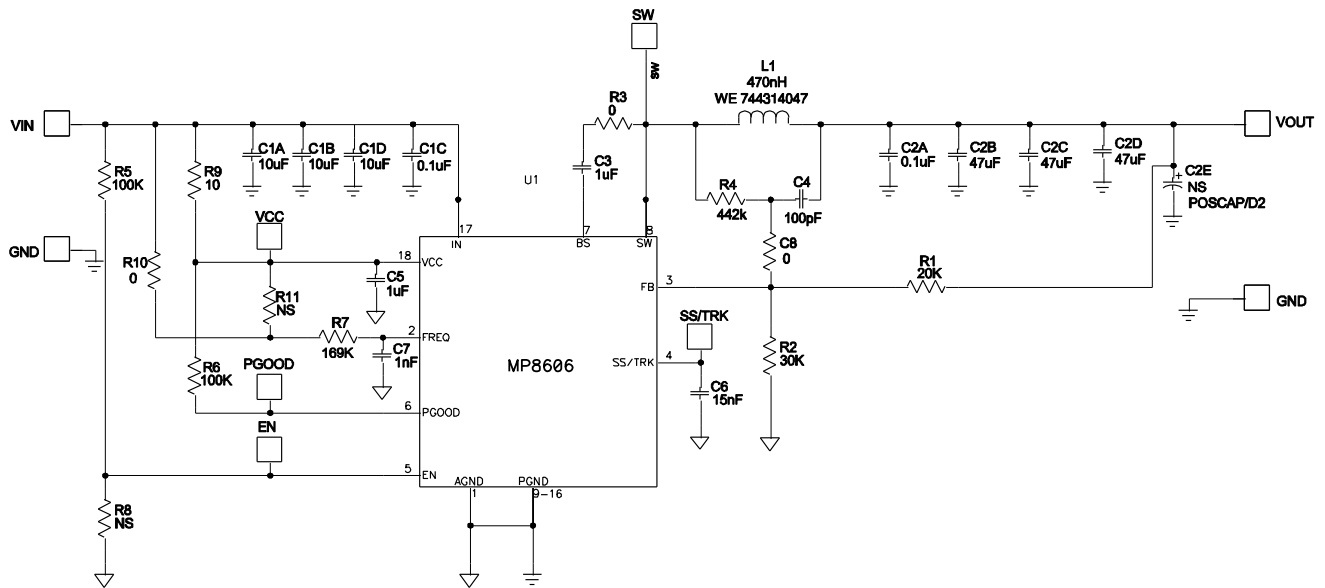

EV8606DL-00A BILL OF MATERIALS

Qty	Ref	Value	Description	Package	Manufacturer	Manufacturer P/N
3	C1A, C1B, C1D	10 μ F	Ceramic Cap., 10V, 10%, X7R	0805	Any	Any
1	C2A	0.1Mf	Ceramic Cap., 50V, 10%, X7R	0603	Any	Any
3	C2B, C2C, C2D	47 μ F	Ceramic Cap., 6.3V, 20%, X5R	1206	muRata	GRM31CR60J476M
0	C2E	NS	POSCAP	D SIZE		
1	C3	1 μ F	Ceramic Cap., 25V, 10%, X7R	0603	muRata	GRM188R71E104K
1	C4	100pF	Ceramic Cap., 50V, 5%, C0G	0603	muRata	GRM1885C1H101J
1	C5	1 μ F	Ceramic Cap., 6.3V, 10%, X7R	0603	muRata	GRM188R70J105K
1	C7	1nF	Ceramic Cap., 50V, 5%, C0G	0603	muRata	GRM1885C1H102J
0	J1	NS	socket	SMA		
1	L1	0.47 μ H	Inductor	1	Wurth	WE-744317047
1	R1	20k	Film Res., 1%	0603	Yageo	RC0603FR-0720K0L
1	R2	30k	Film Res., 1%	0603	Yageo	RC0603FR-0300K0L
3	R3, C8, R10	0	Film Res., 5%	0603	Yageo	RC0603JR-070R0L
1	R4	442k	Film Res., 1%	0603	Yageo	RC0603FR-07442KL
2	R5, R6	100k	Film Res., 1%	0603	Yageo	RC0603FR-07100KL
1	R7	169k	Film Res., 1%	0603	Yageo	RC0603FR-07169KL
0	R8, R11	NS		0603		
1	R9	10	Film Res., 5%	0603	Yageo	RC0603JR-0710L
1	U1	IC	Synch Step-Down converter	QFN20	MPS	MP8606DL

PRINTED CIRCUIT BOARD LAYOUT

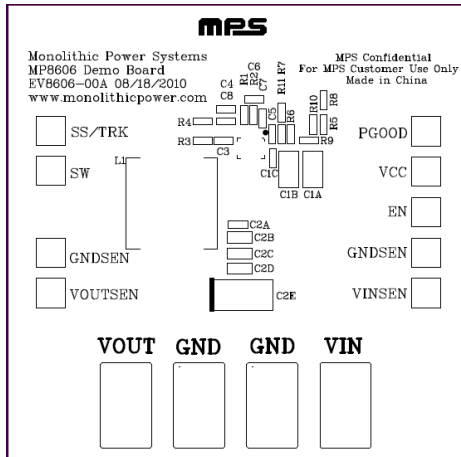

Figure 1—Top Silk Layer

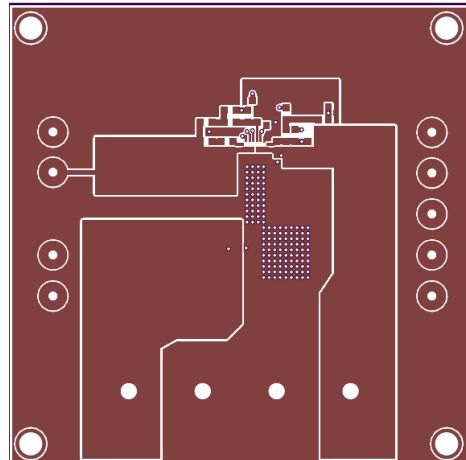

Figure 2—Top Layer

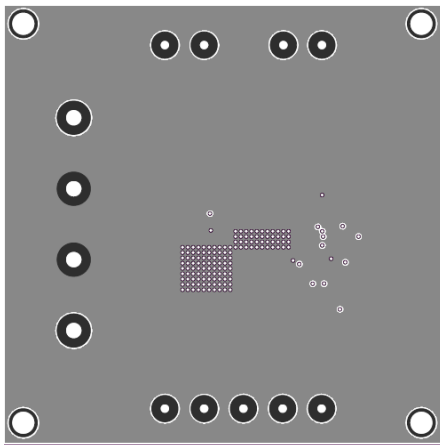

Figure 3—Inner Layer 1

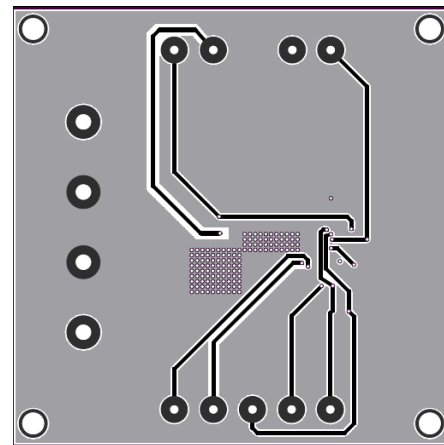

Figure 4— Inner Layer 2

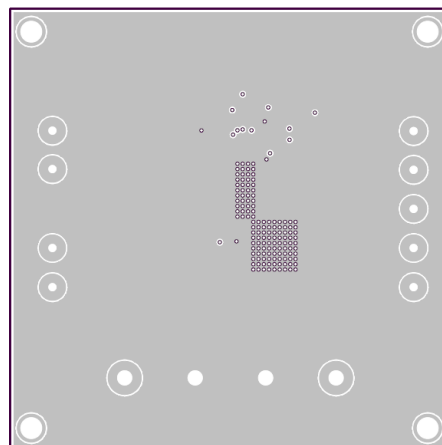

Figure 5—Bottom Layer

QUICK START GUIDE

The default output voltage of this board is set to 1V.

The board layout accommodates most commonly used inductors and output capacitors.

1. Attach the positive and negative ends of the load to the VOUT and GND pins, respectively.
2. Attach the input voltage ($2.9V \leq V_{IN} \leq 6V$) and input ground to the VIN and GND pins, respectively. Then the board is powered up.
3. The EV8606DL-00A is enabled ON in default. It's turned on once the input voltage is applied. To enable the board externally, apply a voltage, $V_{EN} \geq 2V$, to the EN pin. To disable the board, apply a voltage, $V_{EN} \leq 0.4V$, to the EN pin.

Setting the Output Voltage

Case 1: POSCAP, OSCON or Aluminum capacitors used in the output

1. Choose a value for R2. A value within $5k\Omega$ - $40k\Omega$ is recommended to ensure stable operation.
2. R1 is determined as follows:

$$R_1 = \frac{V_{OUT} - V_{REF}}{V_{REF}} \times R_2$$

Where V_{REF} is 0.6V

Case 2: Ceramic capacitors used in the output

An external voltage ramp should be added to FB through resistor R4 and capacitor C4.

1. Choose a value for C4 within 100-680pF.
2. Determine R4 as follows:

$$V_{RAMP} = \frac{(V_{IN} - V_{OUT}) \times T_{ON}}{R4 \times C4}$$

Where V_{ramp} is the external ramp voltage generated to FB. 30mV should be enough for most of the applications.

3. Choose a value within $5k\Omega$ - $40k\Omega$ for R2.
4. The value of R1 then is determined as follows:

$$R1 = \frac{1}{\frac{V_{REF} + \frac{1}{2} V_{RAMP}}{R2(V_{OUT} - V_{REF} - \frac{1}{2} V_{RAMP})} - \frac{1}{R4}}$$

5. Make sure the ramp circuit impedance is much smaller than the FB circuit impedance as follows:

$$\frac{1}{2\pi \times F_s \times C4} < \frac{1}{5} \left(\frac{R1 \times R2}{R1 + R2} \right)$$

If not, restart from step 1 until it fulfills the above condition.

Layout Recommendation

1. Put the input capacitors (C1A) as close as to the VIN pin.
2. Put the decoupling capacitor (C5) as close as to the VCC pin.
3. Put the inductor as close as to SW pin. Make the SW pad as small as possible to minimize the switching noise interference.
4. Place feedback resistor divider close to the FB pin. The FB pin is directly connected to the PWM comparator. It should be routed away from the noisy SW node.

NOTICE: The information in this document is subject to change without notice. Users should warrant and guarantee that third party Intellectual Property rights are not infringed upon when integrating MPS products into any application. MPS will not assume any legal responsibility for any said applications.