

DESCRIPTION

The EV8352DL-01A is an evaluation board for the MP8352, a 600 kHz step-down regulator.

An integrated 45mΩ power MOSFETS provides 6A continuous load current.

Current mode control provides fast transient response and eases loop stabilization.

This device, available in a space saving 3mm x 4mm 14-pin QFN package, provides a very compact system solution with minimal reliance on external components.

ELECTRICAL SPECIFICATIONS

Parameter	Symbol	Value	Units
Input Voltage	V _{IN}	3 – 6	V
Output Voltage	V _{OUT}	2.5	V
Output Current	I _{OUT}	6	A

FEATURES

- 3V to 6V Operating Input Range
- 6A Continuous Output Current
- 45mΩ Internal Power MOSFET Switch
- Fixed 600kHz Frequency
- Synchronizable Up to 1.5MHz
- Cycle-by-Cycle Over Current Protection with Hiccup
- Thermal Shutdown
- Available in a 3mm x 4mm 14-Pin QFN Package

APPLICATIONS

- Point of Load Regulator in Distributed Power System
- Digital Set Top Boxes
- Personal Video Recorders
- Broadband Communications
- Flat Panel Television and Monitors

"MPS" and "The Future of Analog IC Technology" are Registered Trademarks of Monolithic Power Systems, Inc.

EV8352DL-01A EVALUATION BOARD

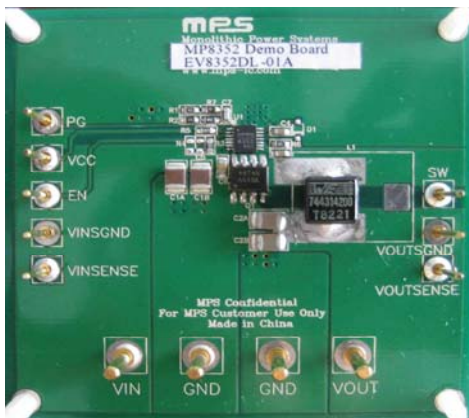

(L x W x H) 2.52" x 2.52" x 0.5"
(6.3cm x 6.3cm x 1.2cm)

Board Number	MPS IC Number
EV8352DL-01A	MP8352DL

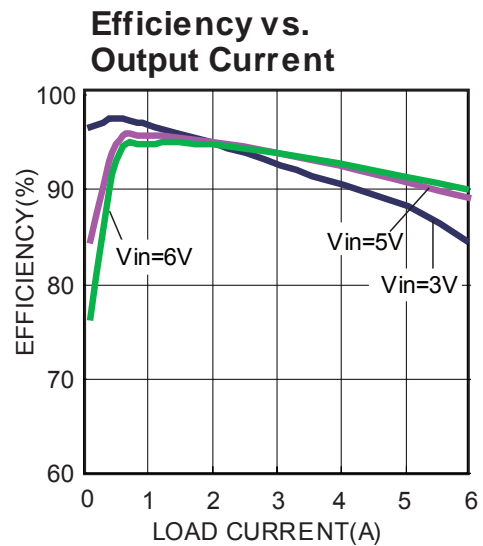

EVALUATION BOARD SCHEMATIC

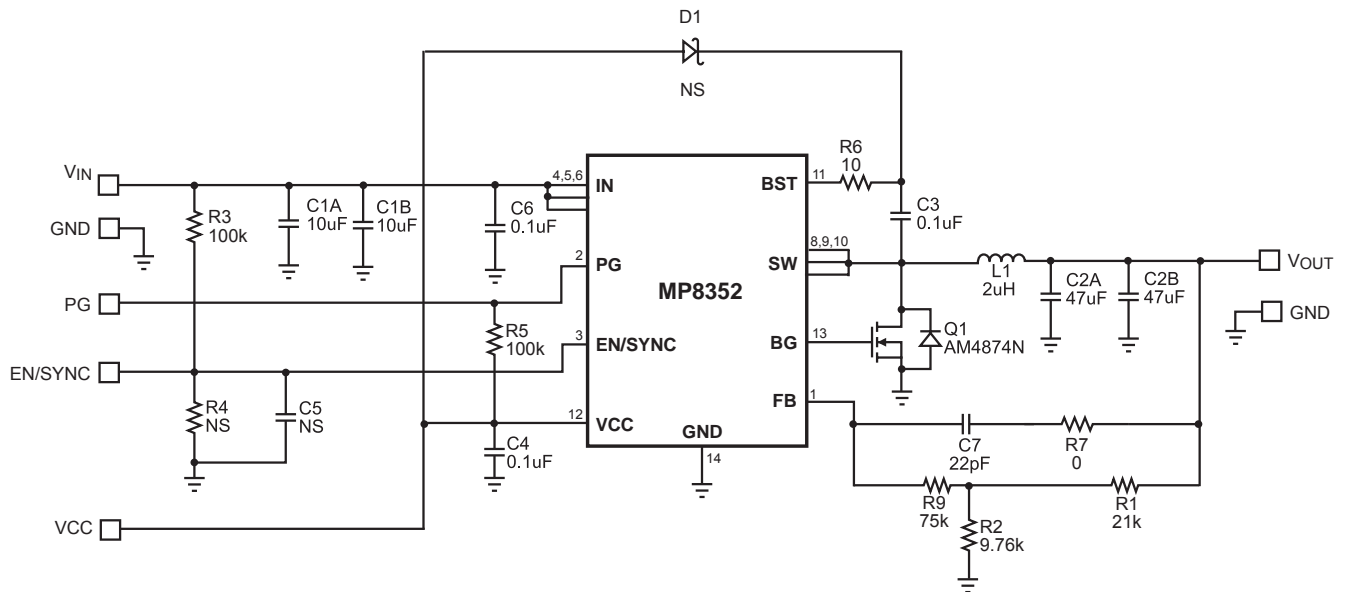

EV8352DL-01A BILL OF MATERIALS

Qty	Ref	Value	Description	Package	Manufacturer	Manufacturer P/N
1	R1	21k	Film Res., 1%	0603	Yageo	RC0603FR-0721KL
1	R2	9.76k	Film Res., 1%	0603	Yageo	RC0603FR-079K76L
2	R3,R5	100k	Film Res., 5%	0603	Any	
0	R4	NS				
1	R6	10	Film Res., 5%	0603	Any	
1	R7	0	Film Res., 5%	0603	Any	
1	R9	75k	Film Res., 5%	0603	Any	
2	C1A,C1B	10uF	Ceramic Cap 16V X5R	1210	TDK	C3225X5R1C106K
2	C2A,C2B	47uF	Ceramic Cap 6.3V X5R	1210	Murata	GRM32ER60J476ME20L
3	C3,C4,C6	0.1uF	Ceramic Cap 16V X7R	0603	Murata	GRM219R71C104KA01D
0	C5	NS				
1	C7	22pF	Ceramic Cap 50V COG	0603	Murata	GRM1885C1H220JA01D
1	D1	NS				
1	U1		Buck PWM Regulator	QFN14	MPS	MP8352DL
1	Q1		30V, 12mΩ, N-Channel	SO8	Analog power	AM4874N
			40V, 12mΩ, N-Channel	Powerpak SO8	Vishay	Si7848
1	L1	1.8uH	7.6mΩ10.4A	SMD	Toko	D104C#919AS-1R8N
		1.9uH	11.5mΩ10.1A	SMD	Copper	HC8LP-1R9-R
		2 uH	5.85mΩ9A	SMD	Würth	744314200

PRINTED CIRCUIT BOARD LAYOUT

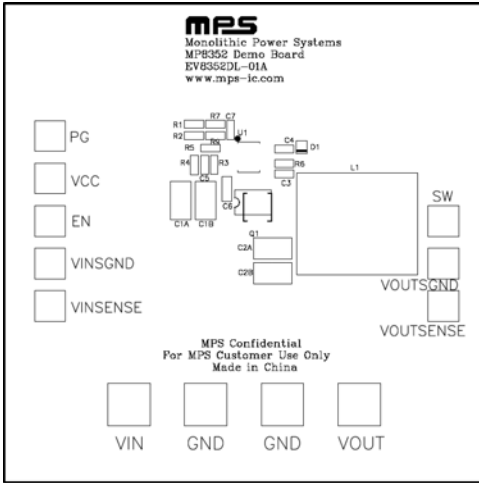

Figure 1—Top Silk Layer

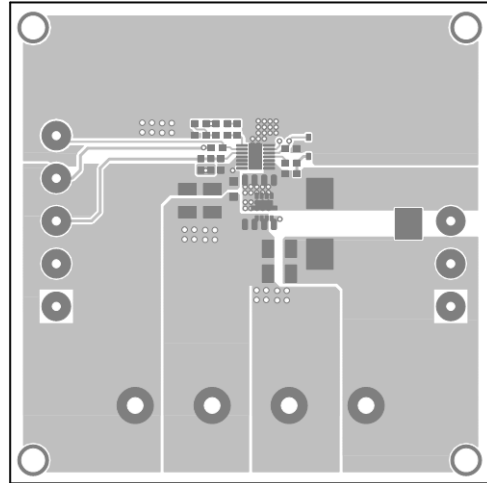

Figure 2—Top Layer

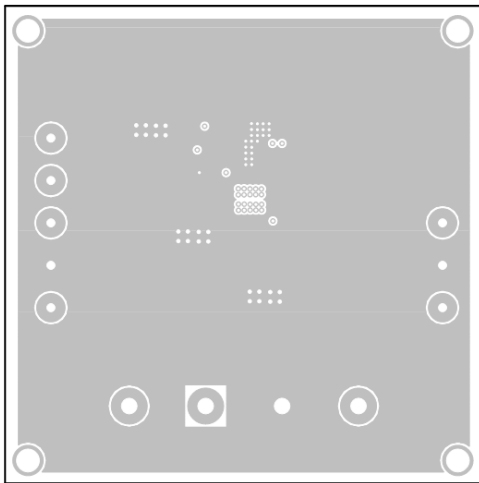

Figure 3—Inner Layer 1

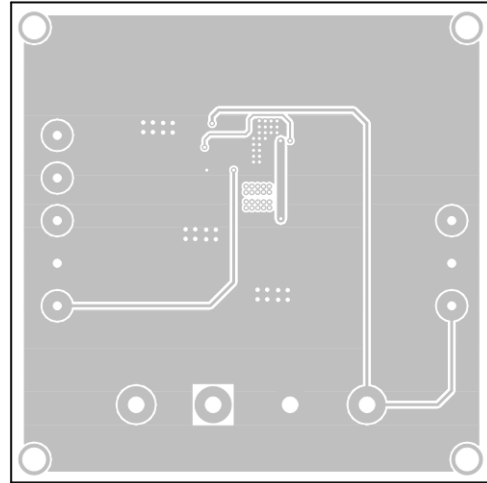

Figure 4—Inner Layer 2

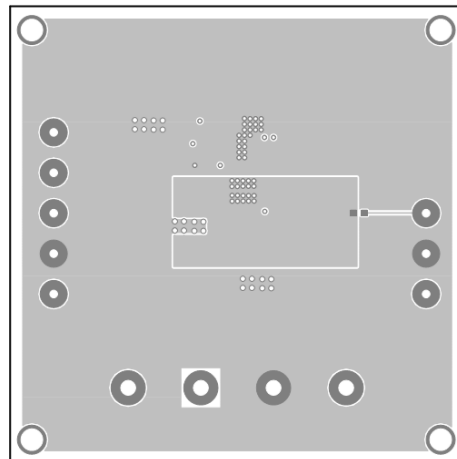

Figure 5—Bottom Layer

QUICK START GUIDE

1. Connect the positive and negative terminals of the load to the VOUT and GND pins, respectively.
2. Preset the power supply output to between 3V and 6V, then turn off the power supply.
3. Connect the positive and negative output terminals of the power supply to the VIN and GND pins respectively, besides, connect Vcc pin to 5V power supply.
4. Turn the power supply on. The board will automatically startup.
5. To use the Enable function, apply a digital input to the EN pin. Drive EN higher than 1.2V to turn on the regulator or less than 0.4V to turn it off.
6. Apply up to 1.5MHz frequency logic level clock signal to the EN pin to synchronize the device to an external clock. The duty cycle is not critical.
7. The output voltage V_{OUT} can be changed by varying R2. Calculate the new value using the formula:

$$R2 = \frac{R1}{\frac{V_{OUT}}{0.8V} - 1}$$

Where $V_{FB}=0.8V$ and $R1=21k\Omega$

For example, for $V_{OUT}=2.5V$

$$R2 = \frac{21k\Omega}{\frac{2.5V}{0.8V} - 1}$$

Therefore use a 9.76k Ω standard 1% value.

NOTICE: The information in this document is subject to change without notice. Users should warrant and guarantee that third party Intellectual Property rights are not infringed upon when integrating MPS products into any application. MPS will not assume any legal responsibility for any said applications.