

### DESCRIPTION

EV8001H-S-00A Evaluation Board is designed to demonstrate the capability of MP8001H's function. MP8001H is an IEEE 802.3af power-over-Ethernet (PoE) compliant powered device (PD) interface controller. It includes detection and classification modes as well as 100V output pass device.

MP8001H has a programmable inrush current during start up, and switches to 810mA when the output pass MOSFET is fully turned on to eliminate the affection of the output inrush current.

A power good(PG) signal which is usually pulled up high through a 100k resistor in application, and sets to low to indicate output capacitor is fully charged, it will be pulled high during OCP and OTP hiccup protection.

The MP8001H is available in a SOIC-8 package.

### ELECTRICAL SPECIFICATIONS

Parameter	Symbol	Value	Units
Input Voltage	V <sub>IN</sub>	37 <sup>(1)</sup> – 57	V
Output Current	I <sub>LIMIT</sub>	450	mA

### FEATURES

- Compatible with 802.3af Specifications
- 100V 1Ω Integrated Pass Switch
- Programmable Inrush Current Limit
- 810mA Operation Current Limit
- Open Drain Power Good Output
- OCP and OTP Hiccup Protection
- Available in a SOIC-8 Package

### APPLICATIONS

- IEEE 802.3af -Compliant Devices
- VoIP Telephones
- Network Cards
- Security Camera Systems
- Safety Backup Power
- Remote Internet Power

All MPS parts are lead-free and adhere to the RoHS directive. For MPS green status, please visit MPS website under Quality Assurance. "MPS" and "The Future of Analog IC Technology" are Registered Trademarks of Monolithic Power Systems, Inc.

**Notes:**

- 1) MP8001H starts up with >42V input, after startup, it can work down to 37V input power, compatible with IEEE802.3af standard.

### EV8001H-S-00A EVALUATION BOARD

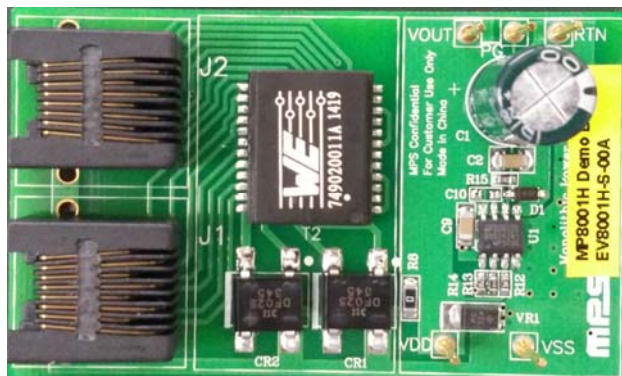

(L x W x H) 2.8" x 1.7" x 0.8"  
(7.1cm x 4.3cm x 2.0cm)

Board Number	MPS IC Number
EV8001H-S-00A	MP8001HGS

Start-Up by PSE Power

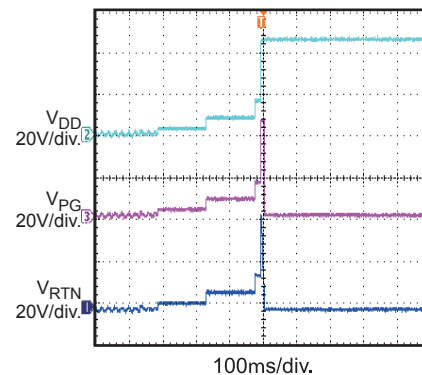

## EVALUATION BOARD SCHEMATIC

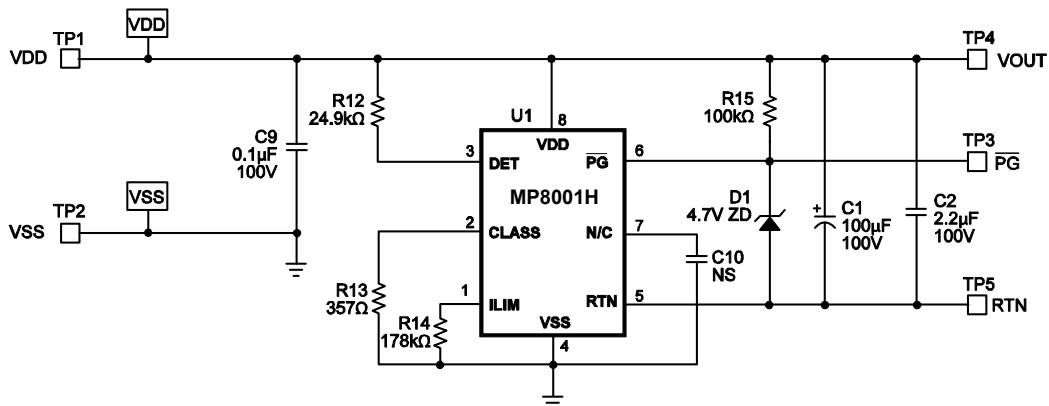
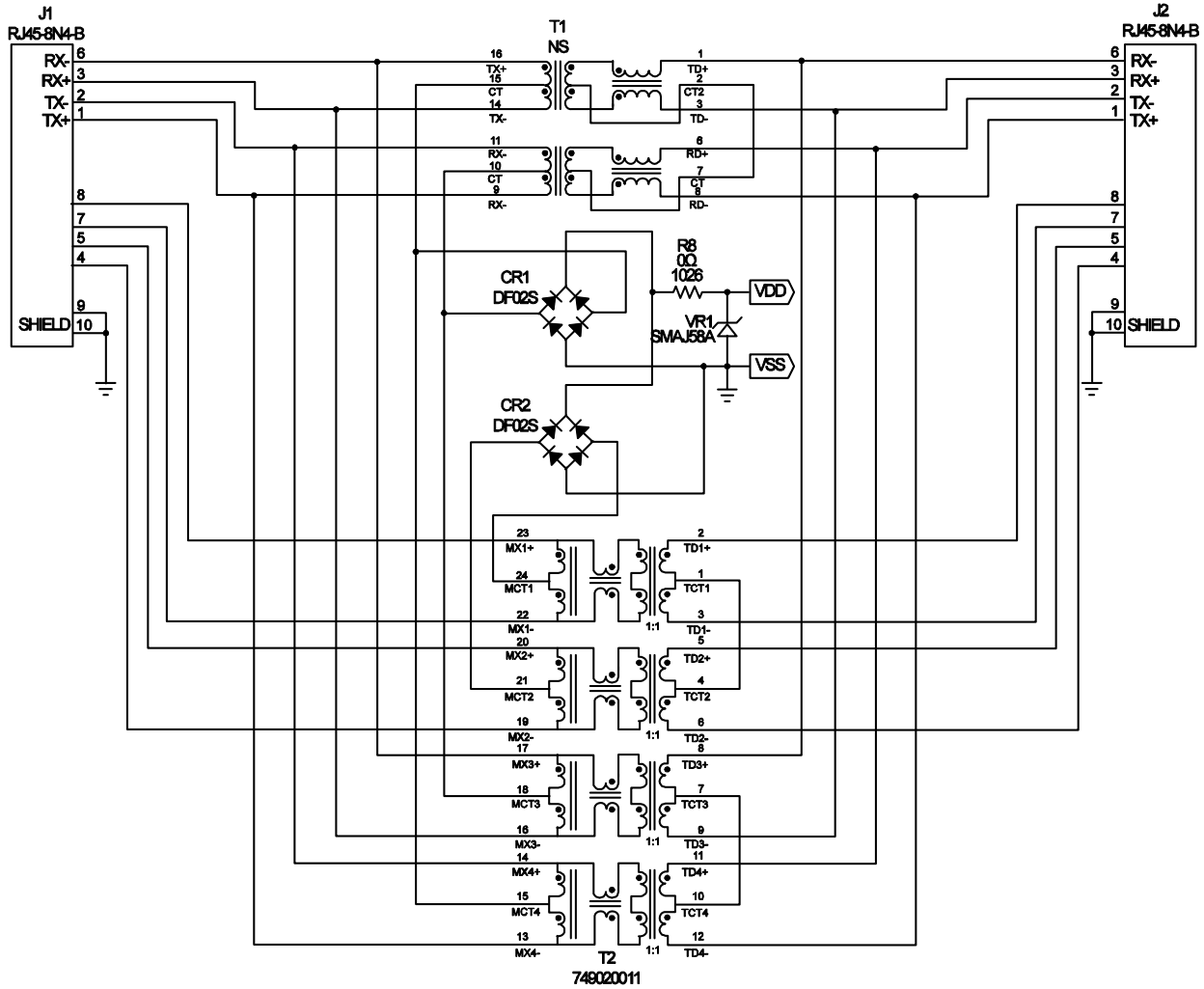

**EV8001H-S-00A BILL OF MATERIALS**

Qty	Ref	Value	Description	Package	Manufacturer	Manufacturer P/N
2	J1, J2	RJ45-8N4-B	RJ Jack / Signal Line EMI/RFI Filters 6 TRMN BRD/CBLE GRND 8 PIN BLOCK INDUCTOR		Tyco Electronics	RJ45-8N4-B
	T1	NS	Not Stuffed			
1	T2	749020011	LAN-Transformer WE-LAN		Würth Elektronik	749020011
1	C1	100µF	100V SU Type Elect. Cap.	Radial	Panasonic - ECG	ECE-A2AU101
1	C2	0.22µF	Ceramic Cap., 100V, X7R	SMC1206	Murata	GRM31MR72A224KA01L
	C9	0.1µF	Ceramic Cap., 100V X7R 1206	SMC1206	Murata	GRM319R72A104KA01L
	C10	NS	Not Stuffed			
2	CR1, CR2	DF02S	1.0A SURFACE MOUNT GLASS PASSIVATED BRIDGE RECTIFIER	DF-S	Diodes Inc	DF02S
1	D1	4.7V	DIODE ZENER 4.7V 500MW SOD- 123	SOD-123	Diodes Inc	BZT52C4V7-13
1	VR1	SMAJ58A	TVS	SMA	Littelfuse	SMAJ58A
1	R8	0Ω	Film Resistor, 5%	SMR1206	Panasonic - ECG	ERJ-8GEY0R00V
1	R12	24.9kΩ	Film Resistor, 1%	SMR0603	Yageo	9T06031A2492DAHFT
1	R13	357Ω	Film Resistor, 1%	SMR0603	Yageo	9T06031A3570DAHFT
1	R14	178kΩ	Film Resistor, 1%	SMR0603	Yageo	9T06031A1783DAHFT
1	R15	100kΩ	Film Resistor, 1%	SMR0603	Yageo	9T06031A1003DAHFT
1	U1	MP8001HGS	PD Controller	SOIC8	MPS	MP8001HGS

## EVB TEST RESULTS

$V_{DD} - V_{SS} = 48V$ ,  $R_{DET} = 24.9k\Omega$ ,  $R_{CLASS} = 357\Omega$ ,  $R_{LIM} = 178k\Omega$ ,  $T_A = 25^\circ C$ , unless otherwise noted.

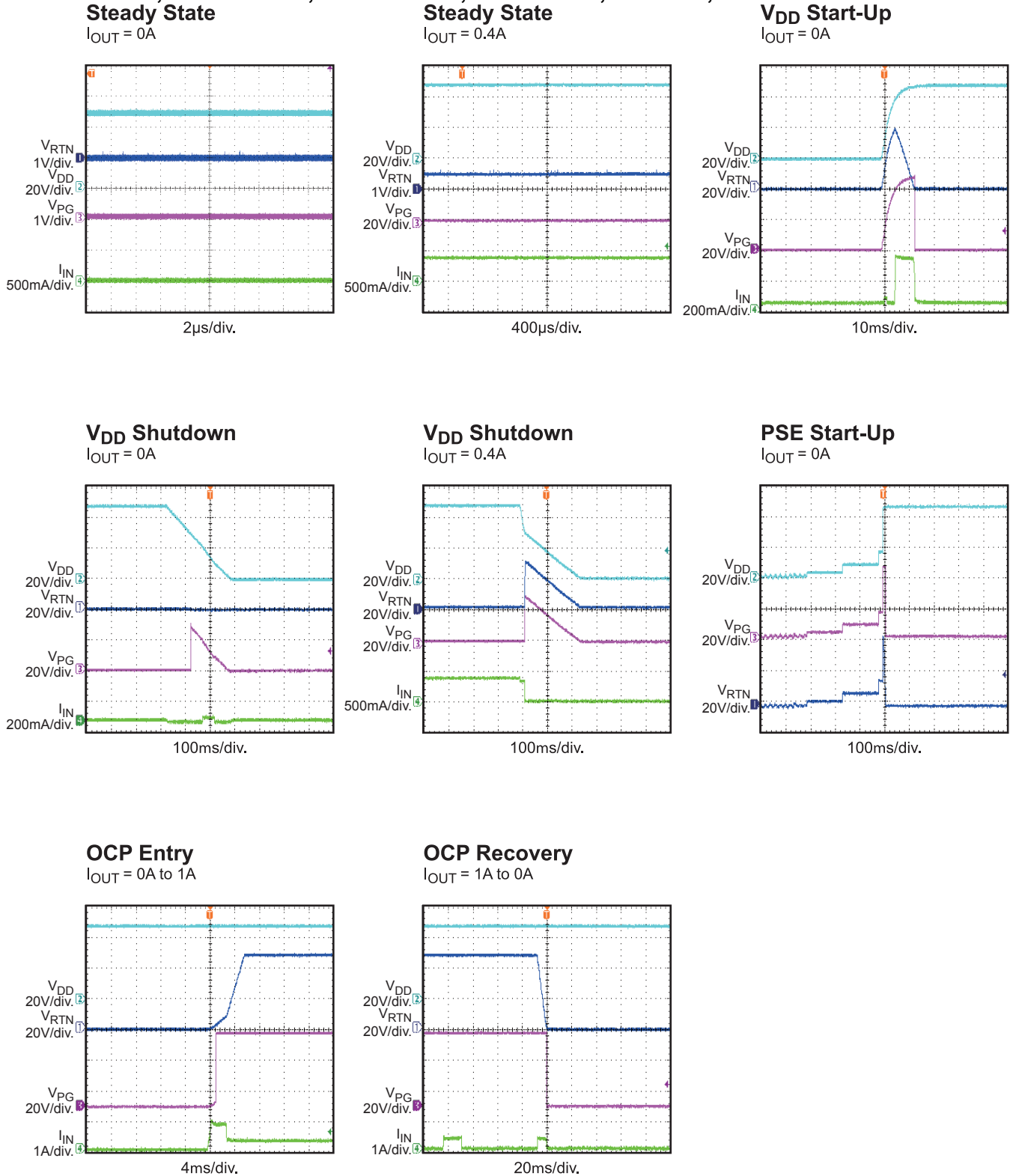

**PRINTED CIRCUIT BOARD LAYOUT**

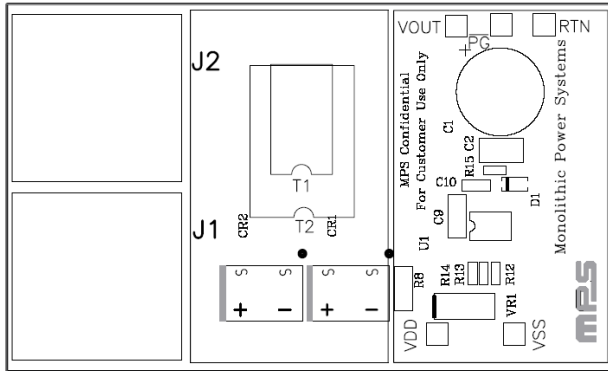

**Figure 1—Top Silk Layer**

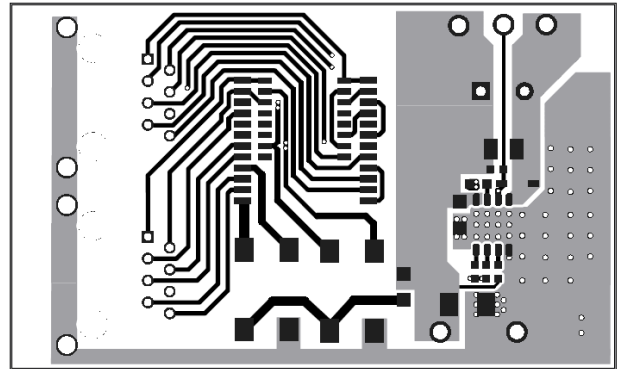

**Figure 2—Top Layer**

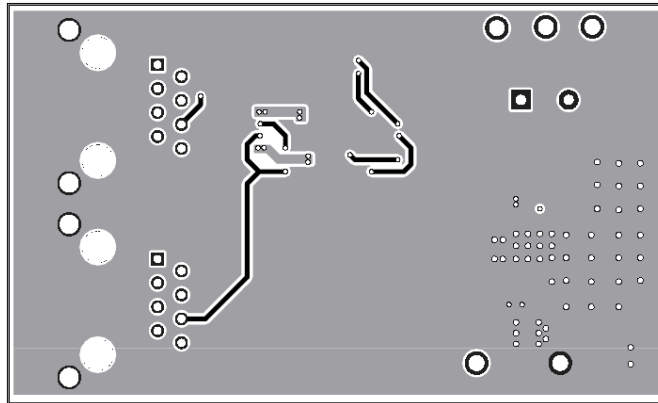

**Figure 3—Bottom Layer**

## QUICK START GUIDE

1. Connect the DC/DC board or load between VOUT (positive) and RTN (negative) terminals.
2. Plug the cable coming from the PSE, carrying the input voltage for the PD, into the Ethernet Jack J1. The board will automatically startup.
3. External DC supply can also be used to evaluate MP8001HGS. Preset the power supply output to 42V – 57V and turn off the power supply. Connect the positive terminal of the power supply output to the VDD pin and the negative terminal of the power supply output to the VSS pin. Turn the power supply on. The board will automatically startup.

**NOTICE:** The information in this document is subject to change without notice. Users should warrant and guarantee that third party Intellectual Property rights are not infringed upon when integrating MPS products into any application. MPS will not assume any legal responsibility for any said applications.