

### DESCRIPTION

The EV6900DS-00A is an evaluation board for the MP6900DS. It is configured to provide synchronous rectification solution for Flyback/LLC topology.

MP6900DS features a synchronous gate output which enables high efficiency rectification by relating the schottky rectifier with a low Ron MOSFET.

### ELECTRICAL SPECIFICATIONS

Parameter	Symbol	Value	Units
Supply Voltage	V <sub>DD</sub>	8–24	V

### FEATURES

- Works with both Standard and Logic Level FETS
- Compatible with Energy Star, 1W Standby Requirements
- V<sub>DD</sub> Range From 8V to 24V
- Fast Turn-off Total Delay of 20ns
- Max 400kHz Switching Frequency
- <3mA Low Quiescent Current
- Supports CCM, DCM and Quasi-Resonant Topologies
- Supports High-side and Low-side Rectification
- Power Savings of Up to 1.5W in a Typical Notebook Adapter

### APPLICATIONS

- Industrial Power Systems
- Distributed Power Systems
- Battery Powered Systems
- Flyback/LLC Converters

"MPS" and "The Future of Analog IC Technology" are Registered Trademarks of Monolithic Power Systems, Inc.

## EV6900DS-00A EVALUATION BOARD



(L x W x H) 1.14" x 1.14" x 0.6"  
2.9cm x 2.9cm x 1.4cm

Board Number	MPS IC Number
EV6900DS-00A	MP6900DS

### EVALUATION BOARD SCHEMATIC

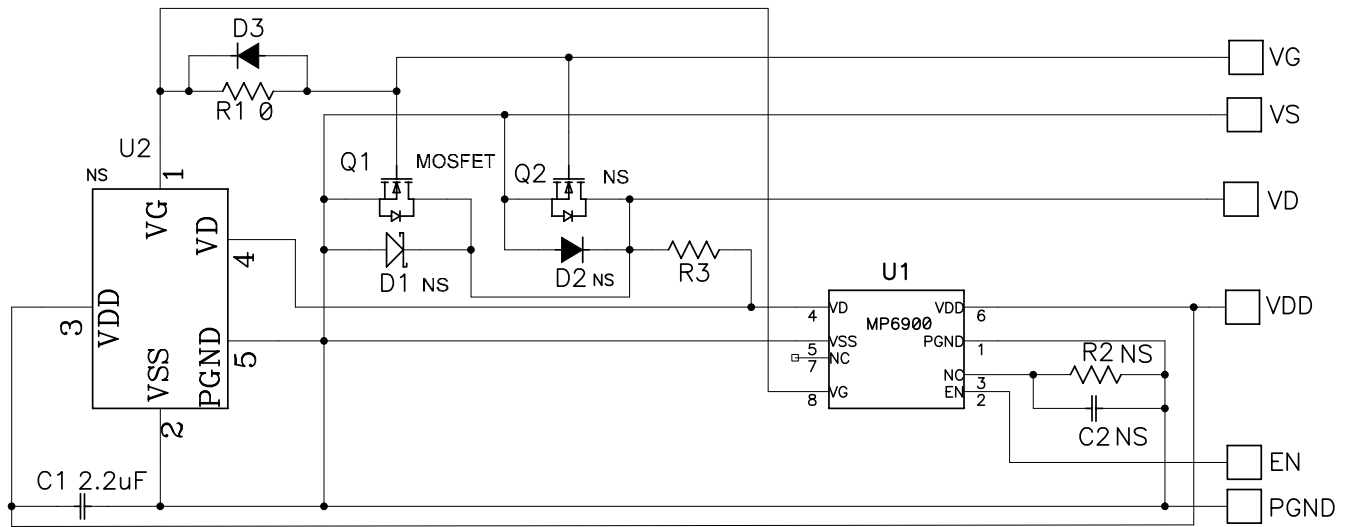

### EV6900DS-00A BILL OF MATERIALS

Qty	Ref	Value	Description	Package	Manufacturer	Manufacturer P/N
1	C1	2.2 $\mu$ F	Ceramic Cap. 25V X7R	0805	muRata	GRM21BR71E225KA73L
0	C2	NS		0603		
2	R1,R3	0	Film Res, 5%	0603	Yageo	RC0603JR-070RL
1	R2	NS		0603		
1	Q1	SUP90N10	N-CH, 100V, 9m $\Omega$	TO220	Vishay	SUP90N10-8M8P
0	Q2	NS		PowerPAK-SO8		
0	D1	NS		TO220		
0	D2	NS		SMC		
1	D3	1N4148	Diodes, 75V	SOD-323	Diodes	1N4148WS
1	U1	MP6900DS	MP6900DS	SO-8	MPS	MP6900DS R0
0	U2	NS		SOT23-5		

**PRINTED CIRCUIT BOARD LAYOUT**

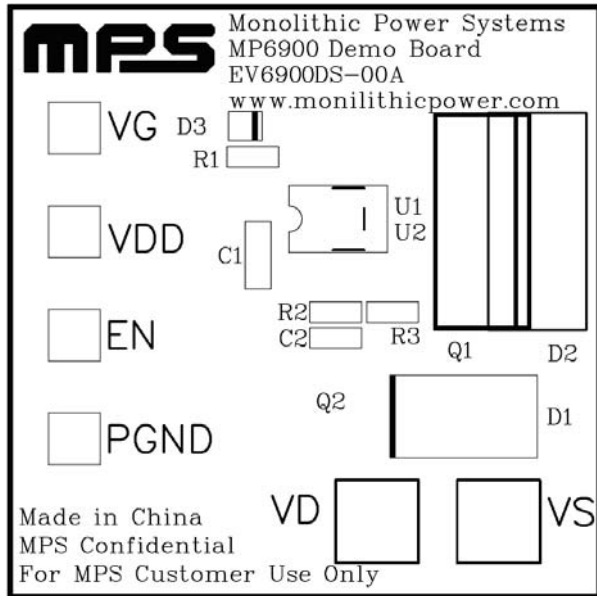

**Figure 1—Top Silk Layer**

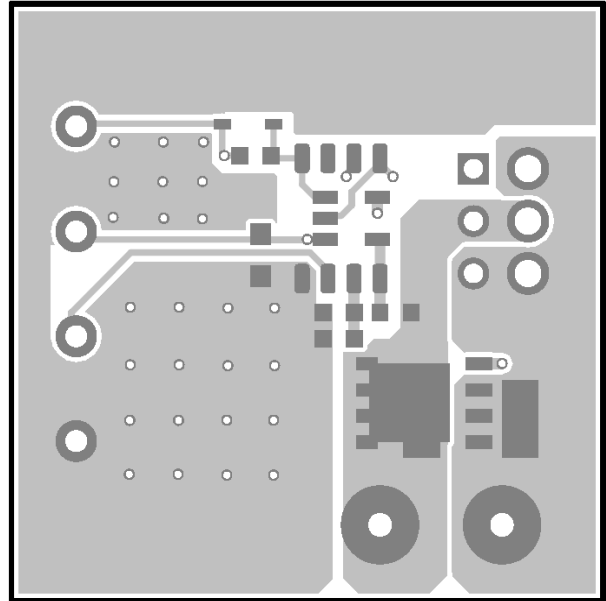

**Figure 2—Top Layer**

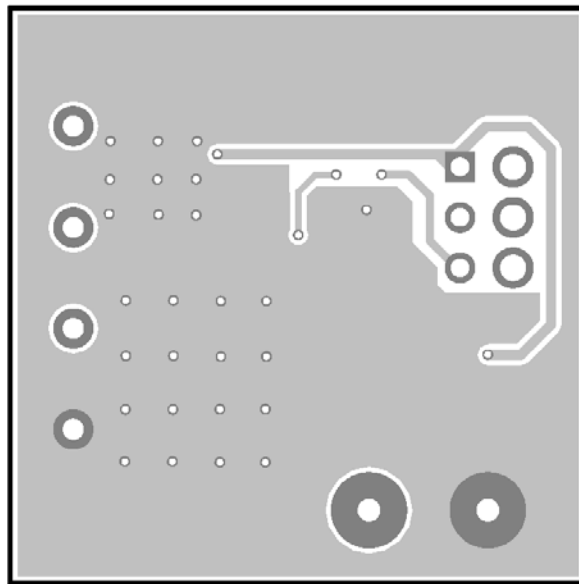

**Figure 3—Bottom Layer**

## QUICK START GUIDE

1. Connect the positive and negative terminals of the output or the auxiliary winding to the VDD and VSS pins, respectively.
2. Connect the Drain and Source and Gate terminals of the synchronous power MOSFET to the VD and VS and VG pins, respectively (There is already a 100V power MOSFET Q1 connected on the board, if the customer do not want to use this MOS as synchronous MOSFET, you can remove this Q1 and use your own MOSFET instead).
3. Preset the input voltage of flyback converter to the normal input range, and then turn off the power supply.
4. Turn the power supply on. The IC will automatically startup and drive the synchronous MOSFET Q1 to work as an ideal diode.

**NOTICE:** The information in this document is subject to change without notice. Users should warrant and guarantee that third party Intellectual Property rights are not infringed upon when integrating MPS products into any application. MPS will not assume any legal responsibility for any said applications.