



EV6530-R-01A

5V to 45V, Three-Phase Brushless DC Motor Pre-Driver Evaluation Board

DESCRIPTION

The EV6530-R-01A is an evaluation board for the MP6530GR, a three-phase BLDC motor pre-driver.

It operates from a supply voltage of up to 45V. It is configured to drive 3 half bridges consisting of 6 N-channel Power MOSFETs. The rotor position information is provided by the Hall sensors assembled in the motor. Motor speed and direction are controlled by an on-board microcontroller.

ELECTRICAL SPECIFICATIONS

Parameter	Symbol	Value	Units
Input Voltage	VIN	5 - 45	V

FEATURES

- Wide 5V to 45V Input Voltage Range
- Hall Sensor Inputs
- Programmable OCP Threshold
- Support 100% Duty Cycle Operation
- OCP, OTP
- Fault Indication Output

APPLICATIONS

- 3-Phase Brushless DC Motors and Permanent Magnet Synchronous Motors
- Power Drills
- Impact Drivers
- E-Bike

All MPS parts are lead-free, halogen free, and adhere to the RoHS directive. For MPS green status, please visit MPS website under Quality Assurance. "MPS" and "The Future of Analog IC Technology" are Registered Trademarks of Monolithic Power Systems, Inc.

EV6530-R-01A EVALUATION BOARD



(L x W x H) 4" x 2.6" x 0.4"
(10cm x 6.5cm x 1cm)

Board Number	MPS IC Number
EV6530-R-01A	MP6530GR

EVALUATION BOARD SCHEMATIC

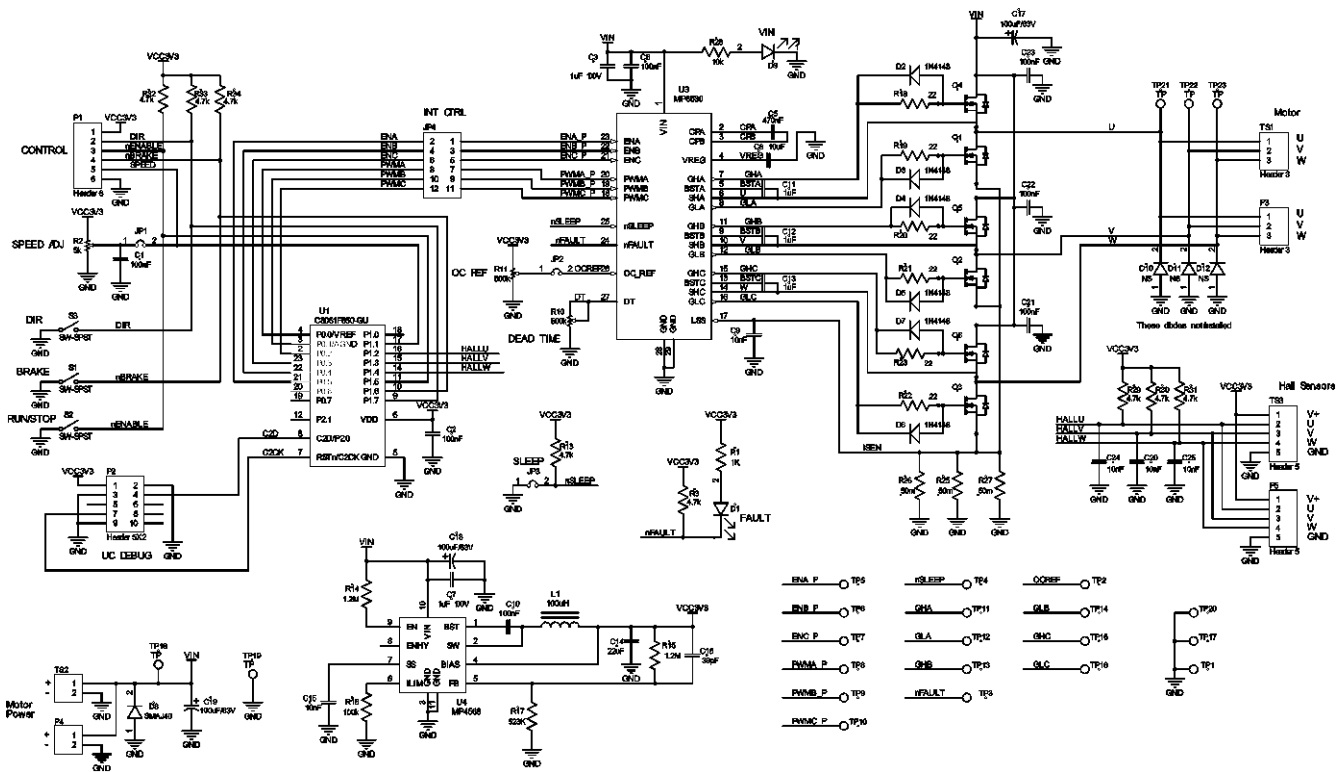

EV6530-R-01A BILL OF MATERIALS

Qty	Ref	Value	Description	Package	Manufacture	Manufacture_PN
7	C1, C2, C6, C10, C21, C22, C23	100nF	Ceramic Capacitor; 100V; X7R	0603	muRata	GRM188R72A104KA35D
2	C3, C7	1 μ F	Ceramic Capacitor; 100V; X7R	1206	muRata	GRM31CR72A105KA01L
1	C5	470nF	Ceramic Capacitor; 50V; X7R	0603	TDK	C1608X7R1H474K
1	C8	10 μ F	Ceramic Capacitor; 25V; X5R	0603	muRata	GRM188R61E106MA73D
3	C11, C12, C13	1 μ F	Ceramic Capacitor; 16V; X7R	0603	muRata	GRM188R71C105KA12D
5	C9, C15, C20, C24, C25	10nF	Ceramic Capacitor; 50V; X7R	0603	muRata	GRM188R71H103JA01D
1	C14	22 μ F	Ceramic Capacitor; 10V; X7R	1206	muRata	GRM31CR71A226KE15L
1	C16	39pF	Ceramic Capacitor; 50V; C0G	0603	muRata	GRM1885C1H390JA01
3	C17, C18, C19	100 μ F	Electrolytic Capacitor; 63V	DIP	Rubycon	63PX100MEFC8X11.5 100uF 63V
2	D1, D9		LED; Red light	0805	佰鸿	2012SURC-11
6	D2, D3, D4, D5, D6, D7		Diode; 0.75V; 0.15A	SOD-123	长电	1N4148W
4	D8, D10, D11, D12	NS				
4	JP1, JP2, JP3, P4		2-Pin; 2.54MM			61304011121
1	JP4		6-Pin; 2.54MM; Dual row			
8	JP1, JP2, JP4		2.54MM Short Jumper			60900213421
1	L1	100 μ H	Inductor; 2.7 Ω ; 180mA	SMD	Murata	LQH32PN101MN0L
1	P1		6-Pin; 2.54MM			61304011121
1	P2		5-Pin; 2.54MM; Dual row			
1	P3		3-Pin; 2.54MM			61304011121
1	P5		5-Pin; 2.54MM			61304011121
6	Q1, Q2, Q3, Q4, Q5, Q6		N-channel MOSFET; 80V; 19A; 9m Ω ; Qg=52nC;	SOIC-8PP	Analog Power	AM7484N
			N-channel MOSFET; 80V; 18A; 13m Ω ; Qg=72nC	SOIC-8PP	Analog Power	AM7482N
1	R1	1k	Film Resistor; 1%	0603	Yageo	RC0603FR-071KL
1	R2	5.1k	Square Trimming Potentiometer	DIP	CTS	296UD502B1N
8	R3, R13, R29, R30, R31, R32, R33, R34	4.7k	Film Resistor; 1%	0603	Yageo	RC0603FR-074K7L
2	R10, R11	500k	Square Trimming Potentiometer	DIP		3266W-1-504LF
2	R14, R15	1.2M	Film Resistor; 1%	0603	Yageo	RC0603FR-071M2L
1	R16	100k	Film Resistor; 1%	0603	Yageo	RC0603FR-07100KL
1	R17	523k	Film Resistor; 1%	0603	Yageo	RC0603FR-07523KL

EV6530-R-01A BILL OF MATERIALS *(continued)*

Qty	Ref	Value	Description	Package	Manufacture	Manufacture_PN
6	R18, R19, R20, R21, R22, R23	22	Film Resistor; 1%	0603	Yageo	RC0603FR-0722L
3	R25, R26, R27	200m	Sense Resistor; 1%; 2W	2512	CTS	73L7R20J
1	R28	10k	Film Resistor; 1%	0603	Yageo	RC0603FR-0710KL
3	S1, S2, S3		Single-Pole, Single-Throw Switch	DIP		SS-12D01EG4
23	TP1, TP2, TP3, TP4, TP5, TP6, TP7, TP8, TP9, TP10, TP11, TP12, TP13, TP14, TP15, TP16, TP17, TP18, TP19, TP20, TP21, TP22, TP23		1.0 公针			
1	TS1		Header; 3-Pin		Würth	691236510003
1	TS2		Header; 2-Pin		Würth	691236510002
1	TS3		Header; 5-Pin		Würth	691210910005
1	U1		Microcontroller C8051F850	QSOP24	Silicon	C8051F850-C-GU
1	U3		3-Phase BLDC Motor Pre-driver	QFN28 (4x4mm)	MPS	MP6530GR
1	U4		Buck converter	QFN10 (3x3mm)	MPS	MP4568GQ

EV6530-R-01A PRINTED CIRCUIT BOARD LAYOUT

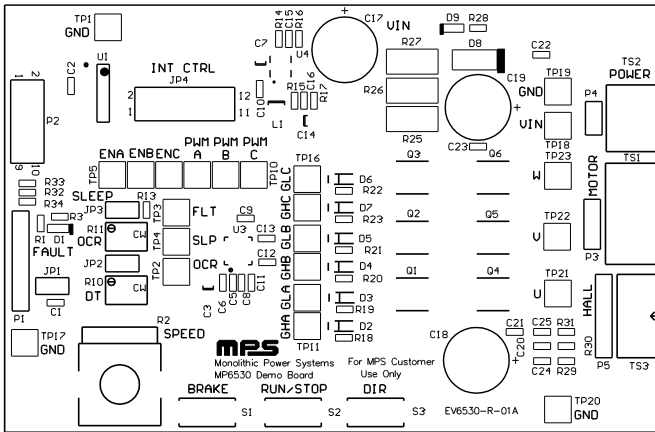

Top Silk

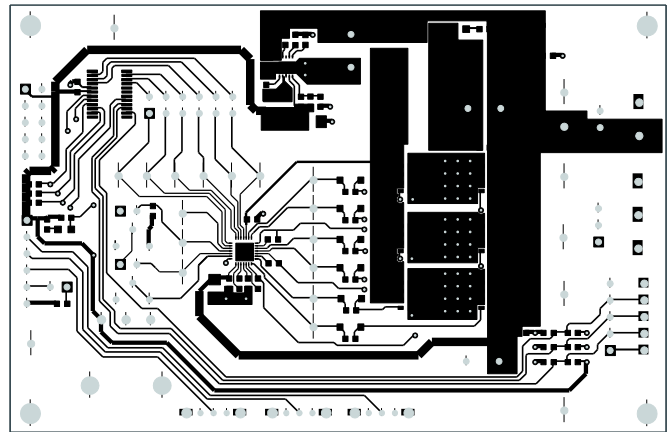

Top Layer

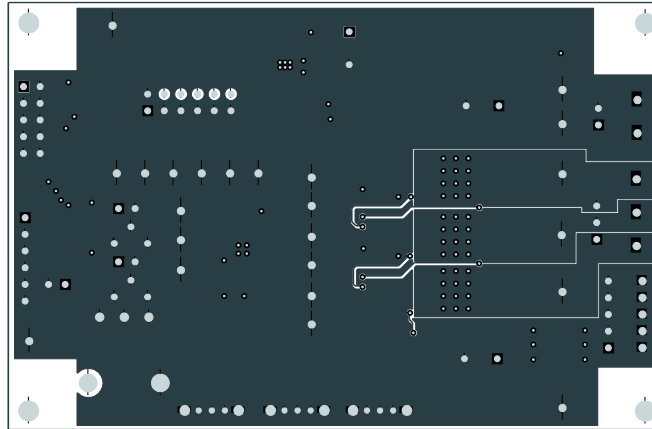

Bottom Layer

QUICK START GUIDE

To quickly start using the EV6530-R-01A BLDC motor driver board, do the following:

1. Connect the U, V, and W wires of a BLDC motor to MOTOR connector. Connect the motor Hall sensors to the HALL connector.
2. Connect a power supply (between 5V and 45V) to the VIN and GND pins.
3. Slide the DIR switch to “FWD” or “REV” to control the direction of the motor. Slide the “RUN/STOP” switch to the right to run the motor. Slide the “BRAKE” switch to the right to apply short braking to the motor.
4. Adjust the motor speed by turning the SPEED pot.

Note:

Please pay attention to the correct input polarity connection, to avoid damage due to reversed connection.

NOTICE: The information in this document is subject to change without notice. Users should warrant and guarantee that third party Intellectual Property rights are not infringed upon when integrating MPS products into any application. MPS will not assume any legal responsibility for any said applications.