



EV6500-F-00A

2.5A, 35V, Bipolar Stepper Motor Driver Evaluation Board

DESCRIPTION

The EV6500-F-00A is an evaluation board for the MP6500GF, a stepper motor driver with a built-in microstepping translator.

It operates from a supply voltage of up to 35V and can deliver a motor current up to 2.5A. It can operate a bipolar stepper motor in full-, half-, quarter-, and eighth-step modes by setting the MS2 and MS1. The input control signals for the MP6500 are applied through the connector, or generated on the board.

ELECTRICAL SPECIFICATIONS

Parameter	Symbol	Value	Units
Input voltage	V _{IN}	4.5 to 35	V
Maximum output current	I _{OUT-L}	2.5	A
Decay mode	Automatic decay		

FEATURES

- Wide 4.5V to 35V Input Voltage Range
- Up to 2.5A Programmable Output Current
- Full-, Half-, Quarter-, and Eighth-Step Mode
- Automatic Decay Mode
- OCP, OVP, OTP
- Fault Indication Output

APPLICATIONS

- Bipolar Stepper Motors
- Printers

All MPS parts are lead-free, halogen-free, and adhere to the RoHS directive. For MPS green status, please visit the MPS website under Quality Assurance. "MPS", the MPS logo, and "Simple, Easy Solutions" are trademarks of Monolithic Power Systems, Inc. or its subsidiaries.

EV6500-F-00A EVALUATION BOARD

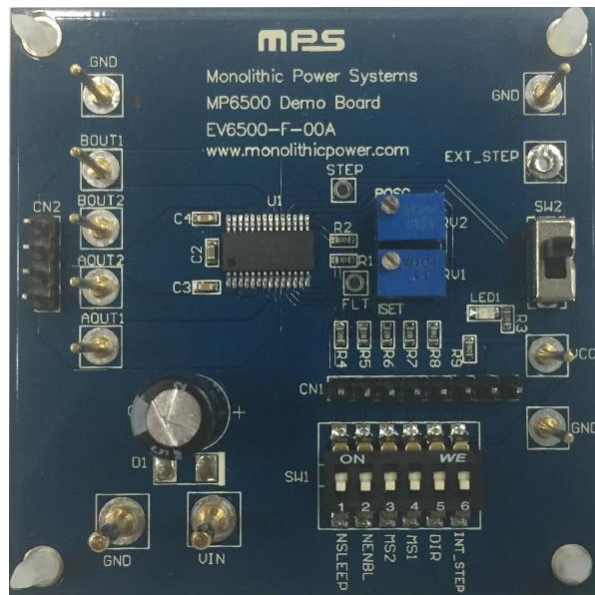

LxWxH 6.35cmx6.35cmx1cm

Board Number	MPS IC Number
EV6500-F-00A	MP6500GF

QUICK START GUIDE

1. Attach the input voltage ($4.5V \leq V_{IN} \leq 35V$) to the VIN connector, and attach the input ground to the GND connector.
2. To enable the external step signal input from the EXT_STEP connector, switch SW2 to position 3 (top side).
3. Attach the step signal to the EXT_STEP connector.
4. The input control and logic signal can be set either through the CN1 connector, the external MCU, or through SW1 via manual action. Manual action requires an external, 5V VCC voltage to be used as a pull-up power supply.

EVALUATION BOARD SCHEMATIC

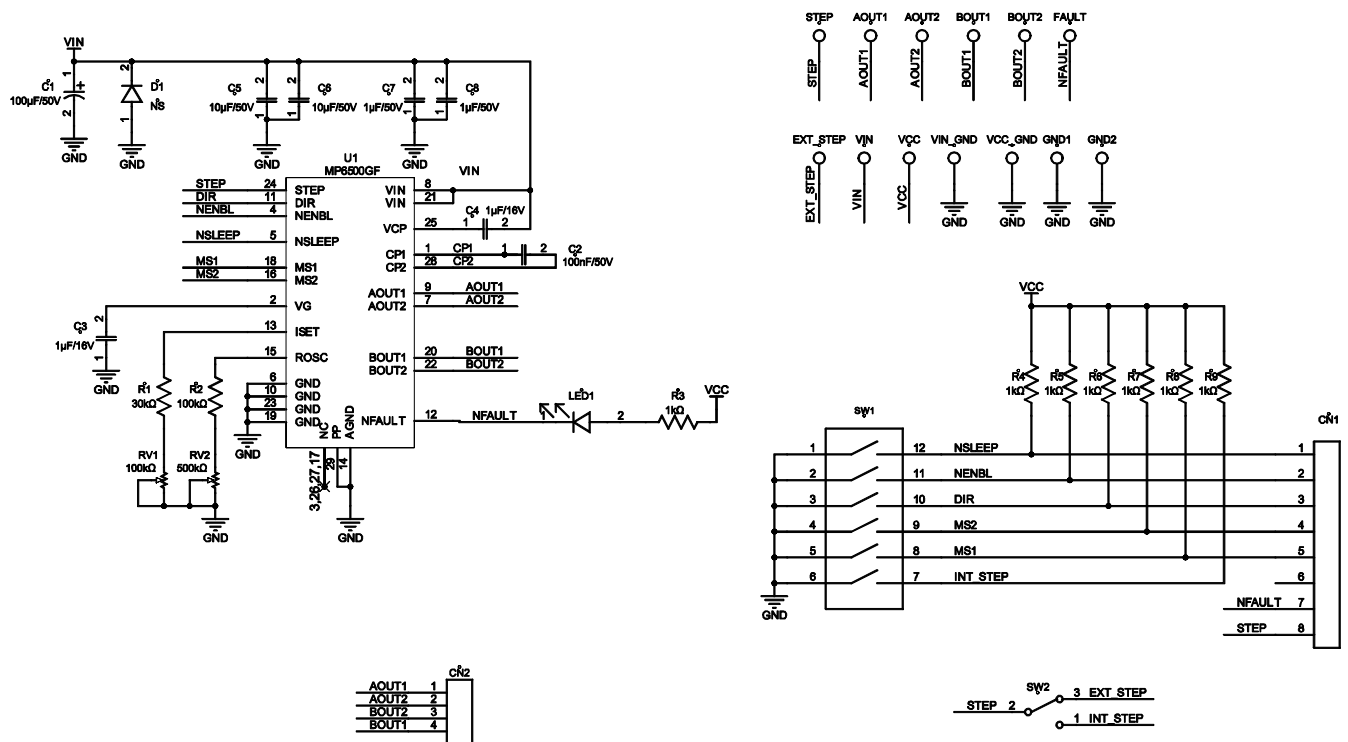

Figure 1: Evaluation Board Schematic

EV6500-F-00A BILL OF MATERIALS

Qty	Ref	Value	Description	Package	Manufacturer	Manufacturer P/N
1	C1	100µF/ 50V	Electrolytic capacitor, 50V	DIP	Rubycon	50YXF100MEFC
1	C2	100nF/ 50V	Ceramic capacitor, 50V, X7R	0805	Murata	GRM21BR71H104KA01L
2	C3, C4	1µF/16V	Ceramic capacitor, 16V, X7R	0603	Murata	GRM188R71C105KA12D
2	C5, C6	10µF/ 50V	Ceramic capacitor, 50V, X7R	1210	Murata	GRM32ER71H106KA12L
2	C7, C8	1µF/50V	Ceramic capacitor, 50V, X7R	0805	Murata	GRM21BR71H105KA12L
7	R3, R4, R5, R6, R7, R8, R9	1kΩ	Film resistor, 1%	0603	Yageo	RC0603FR-071KL
1	R1	30kΩ	Film resistor, 1%	0603	Yageo	RC0603FR-0730KL
1	R2	100kΩ	Film resistor, 1%	0603	Yageo	RC0603FR-07100KL
1	RV1	100kΩ	Square trimming potentiometer	DIP	Bourns	3266W-1-104LF
1	RV2	500kΩ	Square trimming potentiometer	DIP	Bourns	3266W-1-504LF
1	LED1	Red	LED	0805	Baihong	BL-HUE35A-AV-TRB
1	SW1	6-bits	Button	SMD	Würth	418121270806
1	SW2	SPDT	Button	DIP	Any	
1	CN1	8-bits/ 2.54mm	Connector	DIP	Any	
1	CN2	4-bits/ 2.54mm	Connector	DIP	Any	
1	D1	NS				
2	STEP, FAULT	Yellow	Test point	DIP	Any	
2	VIN, VIN_GN D	Φ = 2mm	Connector	DIP	Any	
9	VCC, VCC_GN D, AOUT1, AOUT2, BOUT1, BOUT2, EXT_ST EP, GND1, GND2	Φ = 1mm	Connector	DIP	Any	
1	U1	35V, 2.5A	Stepper motor driver	TSSOP-28 EP	MPS	MP6500GF

PCB LAYOUT

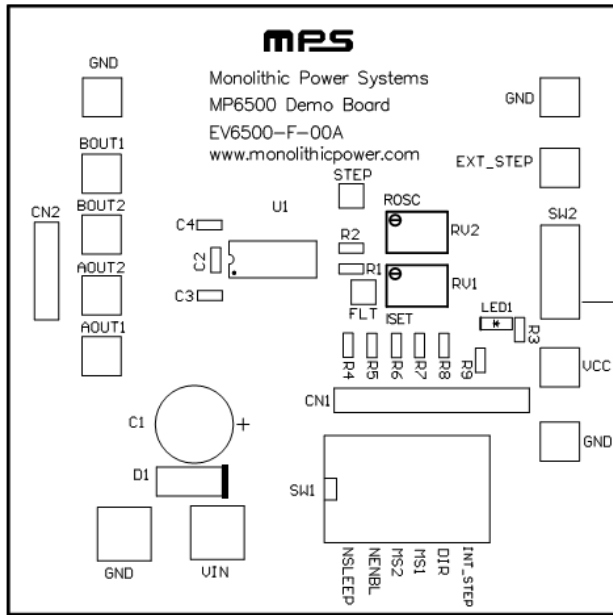

Figure 2: Top Silk Layer

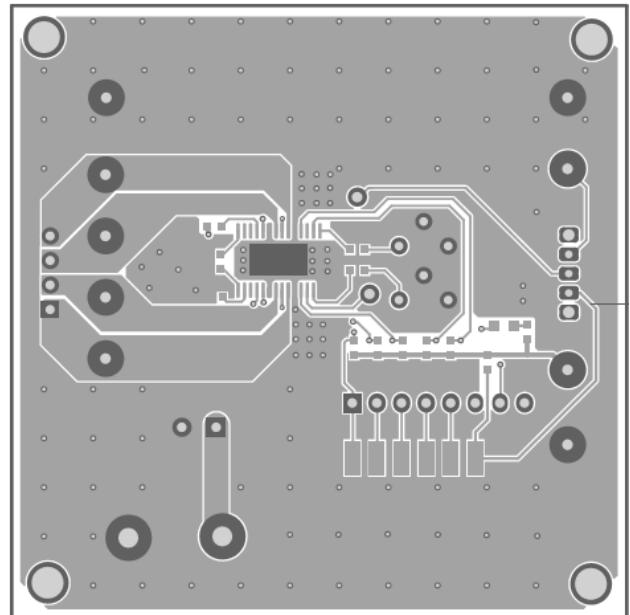

Figure 3: Top Layer

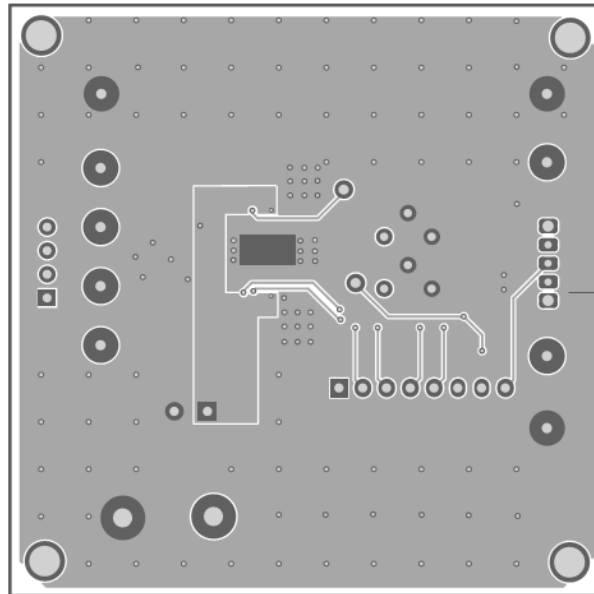

Figure 4: Bottom Layer

Notice: The information in this document is subject to change without notice. Users warrant and guarantee that third-party Intellectual Property rights are not infringed upon when integrating MPS products into any application. MPS will not assume any legal responsibility for any said applications.