



The Future of Analog IC Technology®

EV6233DH-00A

Dual Channel 1.5A

Current-Limited Power Distribution Switches

DESCRIPTION

The EV6233DH-00A is an evaluation board for the MP6233DH, two-channel, current-limited, power-distribution switches.

The EVB operate over a 2.7V to 5.5V range and provide a continuous output current of up to 1.5 A for each channel. They are available with guaranteed current limits, making them ideal for load switching applications. When the output load exceeds the current-limit threshold or a short is present, the device limits the output current to a safe level by switching into a constant-current mode.

This device, available in a MSOP8 with exposed pad, provides a very compact system solution with minimal reliance on external components.

FEATURES

- Dual Channel
- Accurate Current Limit
- 2.7V to 5.5V Supply Range
- Under-Voltage Lockout
- EN Active High
- Flag indicate when over-current, output short encountered.

APPLICATIONS

- Smart phone and PDA
- Portable GPS Device
- Notebook PC
- Set-top-box
- Telecom and Network Systems
- PC Card Hot Swap
- USB Power Distribution

ELECTRICAL SPECIFICATIONS

Parameter	Symbol	Value	Units
Input Voltage	V _{IN}	2.7– 5.5	V
Output Voltage	V _{OUT}	2.7-5.5	V
Output Current	I _{OUT}	1.5	A

"MPS" and "The Future of Analog IC Technology" are Registered Trademarks of Monolithic Power Systems, Inc.

EVALUATION BOARD

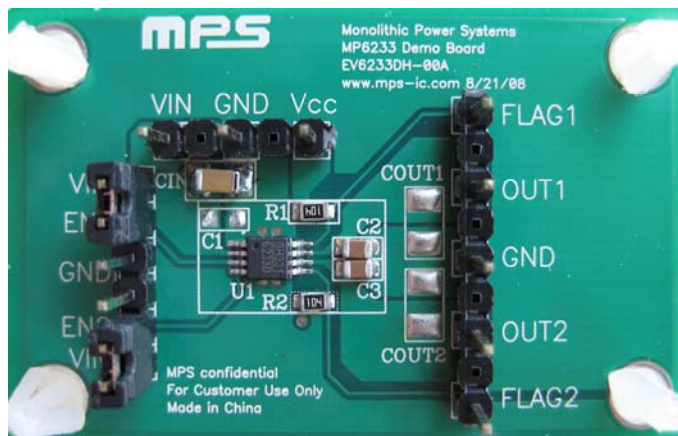

(L x W x H) 2.0" x 1.2" x 0.5"
(5.0cm x 3cm x 1.2cm)

Board Number	MPS IC Number
EV6233DH-00A	MP6233DH

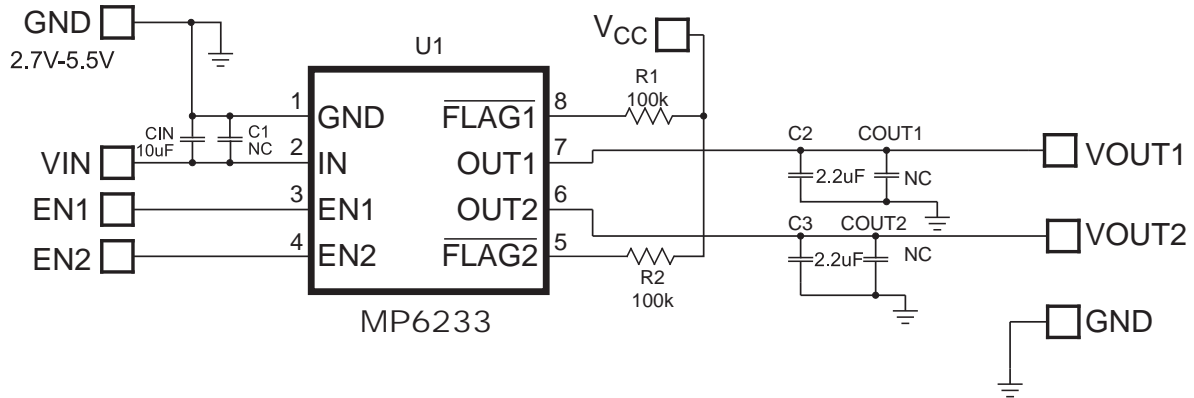
EVALUATION BOARD SCHEMATIC

EVALUATION BOARD SCHEMATIC BILL OF MATERIALS

Qty	RefDes	Value	Description	Package	Manufacturer	Manufacturer P/N
1	CIN	10uF	Ceramic Cap, 16V,X7R	1206	Murata	GRM31CR71C106KAC7L
2	C2, C3	2.2uF	Ceramic Cap, 16V,X5R	0805	TDK	C2012X5R1A225K
3	C1, COUT1, COUT2	NC				
2	R1, R2	100K	Film Res, 5%	0805	Any	
1	U1			MSOP/E	MPS	MP6233DH

PRINTED CIRCUIT BOARD LAYOUT

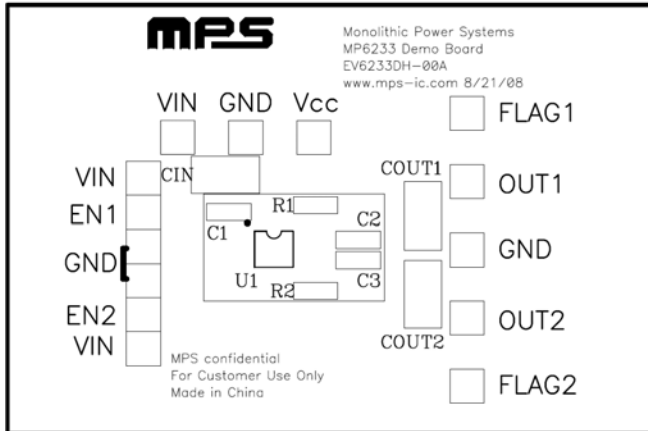

Figure 1—EV6233DH Top Silk Layer

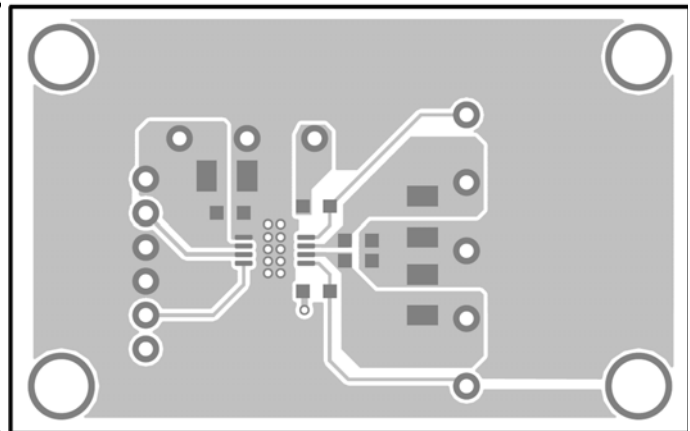

Figure 2—EV6233DH Top Layer

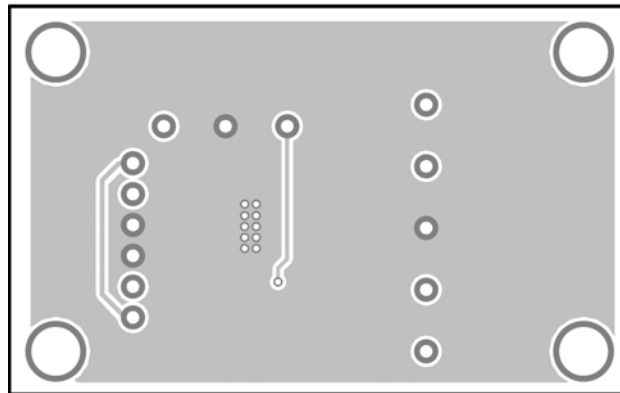

Figure 3—EV6233DH Bottom Layer

QUICK START GUIDE

1. Connect the positive and negative terminals of the load to the VOUT and GND pins, respectively.
2. Preset the power supply output to between 2.7V and 5.5V, then turn off the power supply.
3. Connect the positive and negative terminals of the power supply output to the VIN and GND pins, respectively.
4. Turn the power supply on. The board will automatically startup.
5. To use the Enable function, apply an input to the EN pin. Drive EN higher than 2V to turn on the regulator or less than 0.4V to turn it off.
6. To use flag indicator, apply a 5V voltage to Vcc pin.

NOTICE: The information in this document is subject to change without notice. Users should warrant and guarantee that third party Intellectual Property rights are not infringed upon when integrating MPS products into any application. MPS will not assume any legal responsibility for any said applications.