

DESCRIPTION

The EV5600EUT-00A is an evaluation board for the MP5600, which is power supply for LCD TV panel bias. It contains a step-down switching regulator to generate the logic supply rail, a step-up switching regulator to generate the source driver supply, two charge-pump controllers to generate a positive output and negative output respectively, and a programmable delay gate pulse management switch. Each regulator features adjustable output, internal soft-start, and timer-delayed fault protection.

The MP5600 has UVLO, Short Circuit Protection, Over Voltage Protection and thermal shutdown protection.

The MP5600 is available in a 40 pins, 5mm x 5mm, thin QFN package.

FEATURES

- 8V to 18V Input Voltage Range
- 7.5V Input Under-voltage Lockout
- Output isolation during Shutdown
- 500kHz or 750kHz Selectable Frequency
- 3.3V 2.5A Step-Down Regulator
- 16V 1.5A Step-up Regulator
- 35V 120mA Positive Charge Pump
- -6V 120mA Negative Charge Pump
- External Capacitor charge control VG OFF and VG ON Start Delay
- Dual Mode, Logic-Controlled, No-Jitter High-Voltage Switch with Programmable Delay
- Power Good signal
- OVP, UVLO, SCP
- 155°C Thermal-Overload Protection
- 40-Pin, 5mm x 5mm, Thin QFN Package

APPLICATIONS

TV LCD PANEL

All MPS parts are lead-free and adhere to the RoHS directive. For MPS green status, please visit MPS website under Products, Quality Assurance page.

"MPS" and "The Future of Analog IC Technology" are registered trademarks of Monolithic Power Systems, Inc.

ADAM (Analog Digital Adaptive Modulation) and AAM (Advanced Asynchronous Mode) are trademarks of Monolithic Power Systems, Inc.

EV5600EUT-00A EVALUATION BOARD

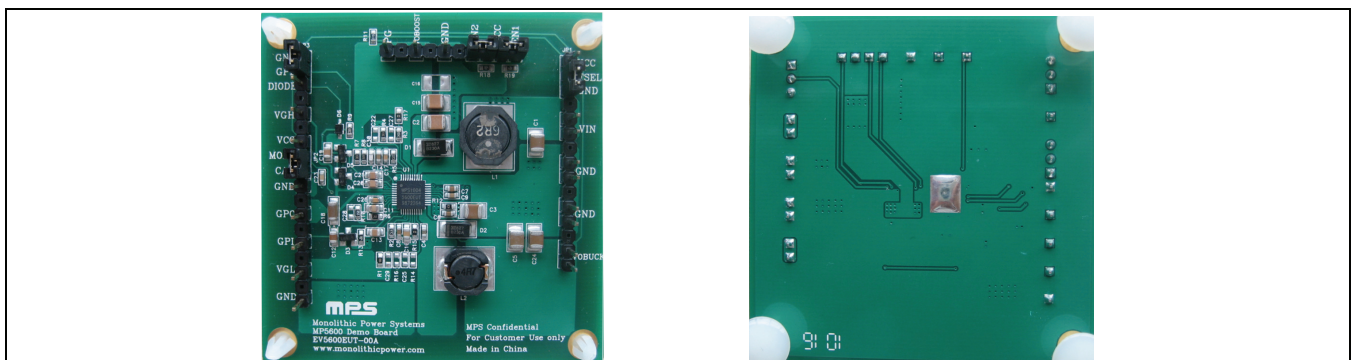

(L x W x H) 6.4cm x 6.4cm x 1.0cm

Board Number	MPS IC Number
EV5600EUT-00A	MP5600EUT

EVALUATION BOARD SCHEMATIC

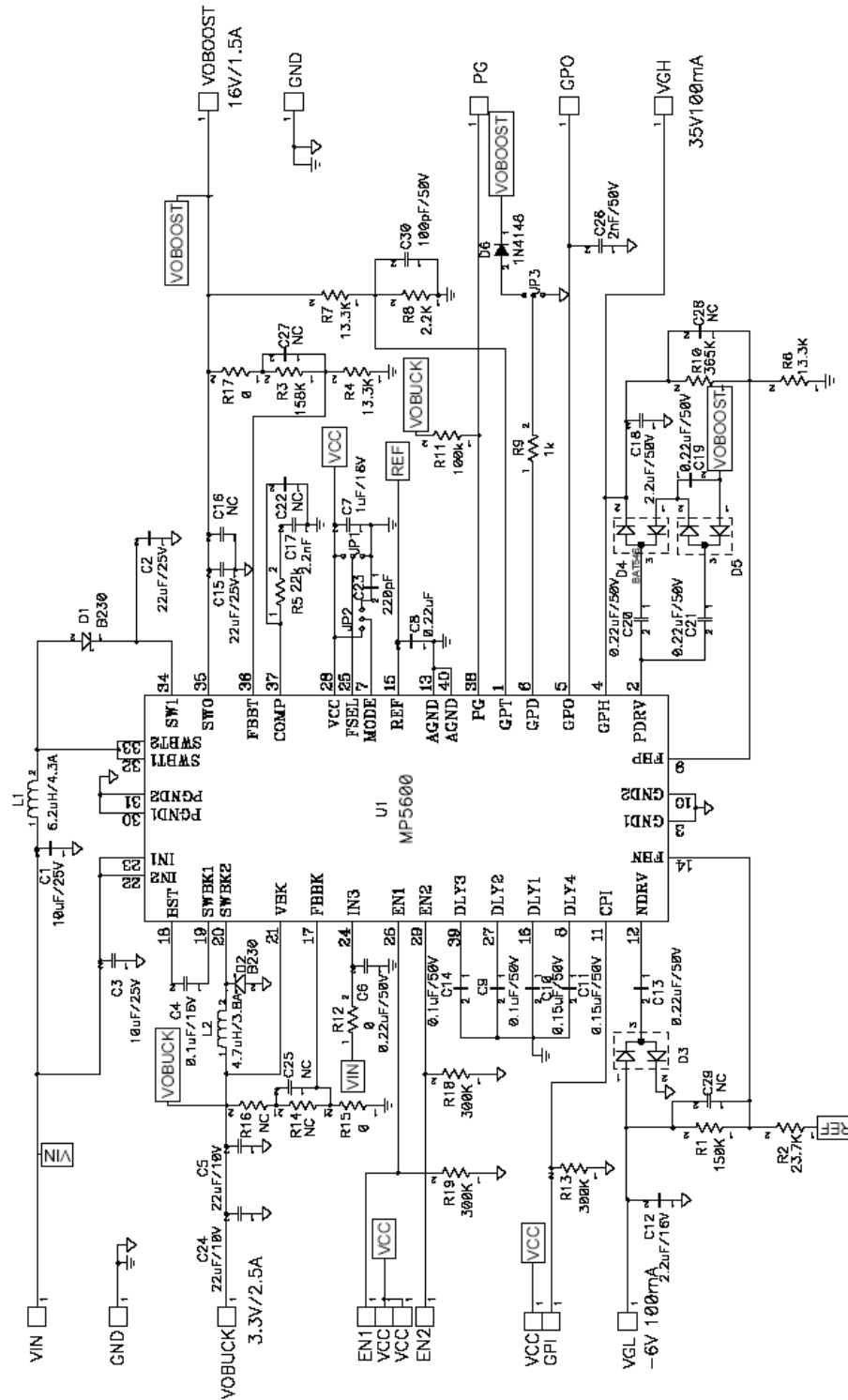

EV5600EUT-00A BILL OF MATERIALS

Qty	Ref	Value	Description	Package	Manufacturer	Part Number
2	C1,C3	10 μ F	Ceramic Capacitor, 25V, X7R	1210	Murata	GRM32DR71E106KA12
2	C2,C15	22 μ F	Ceramic Capacitor, 25V, X7R	1210	Murata	GRM32ER61E226KE15L
1	C4	0.1 μ F	Ceramic Capacitor, 16V, X7R	0603	Murata	GRM188R71C104KA01D
2	C5,C24	22 μ F	Ceramic Capacitor, 10V, X7R	1210	Murata	GRM32ER71E226KE20L
1	C6	0.1 μ F	Ceramic Capacitor, 50V, X7R	0603	Murata	GRM188R71C104KA93D
1	C7	1 μ F	Ceramic Capacitor, 16V, X7R	0603	Murata	GRM188R71C105KA12D
1	C8	0.22 μ F	Ceramic Capacitor, 16V, X7R	0603	TDK	GRM188R71H224KA01
2	C9,C14	0.1 μ F	Ceramic Capacitor, 25V, X7R	0603	Murata	GRM188R71E104KA01D
2	C10,C11	0.15 μ F	Ceramic Capacitor, 50V, X7R	0805	Murata	GRM21BR71C154KA93D
1	C12	2.2 μ F	Ceramic Capacitor, 16V, X7R	0805	Murata	GRM21BR71C225KA12L
4	C13,C19, C20,C21	0.22 μ F	Ceramic Capacitor, 50V, X7R	0805	TDK	C2012X7R1H224K
	C16	NC		1210		
2	C17,C26	2.2nF	Ceramic Capacitor, 50V, X7R	0603	Murata	GRM188R71H222KA01
1	C18	2.2 μ F	Ceramic Capacitor, 50V, X7R	1206	Murata	GRM31CR71H225KA88L
5	C22,C25,C27, C28,C29	NC		0603		
1	C23	220pF	Ceramic Capacitor, 50V, X7R	0603	Murata	GRM188R71H221KA01
1	C30	100pF	Ceramic Capacitor, 50V, X7R	0603	Murata	GRM1885C1H101JA01D
2	D1,D2		Diode Schottky, 30V, 2A	SMB	Diodes Inc	B230
3	D3,D4,D5		Diode Schottky, 30V, 200mA	SOT-23	Diodes Inc	BAT54S
1	D6		Diode Schottky,		Diodes Inc	1N4148
1	L1	6.2 μ H	Inductor,4.3A	SMD	WURTH	7440660062
1	L2	4.7 μ H	Inductor,3.8A	SMD	TOKO	DS84LC-B1015AS-4R7N
1	R1	150k Ω	Resistor, 1%	0603	Yageo	RC0603FR-07150KL
1	R2	23.7k Ω	Resistor, 1%	0603	Yageo	RC0603FR-023K7L
1	R3	158k Ω	Resistor, 1%	0603	Yageo	RC0603FR-07158KL
3	R4,R6,R7	13.3k Ω	Resistor, 1%	0603	Yageo	RC0603JR-0713K3L
1	R5	22k Ω	Resistor, 1%	0603	Yageo	RC0603JR-0722KL
1	R8	2.2k Ω	Resistor, 1%	0603	Yageo	RC0603FR-072K2L

EV5600EUT-00A BILL OF MATERIALS *(continued)*

Qty	Ref	Value	Description	Package	Manufacturer	Part Number
1	R9	1k Ω	Resistor, 1%	0603	Yageo	RC0603FR-071KL
1	R10	365k Ω	Resistor, 1%	0603	Yageo	RC0603FR-07365KL
1	R11	100k Ω	Resistor, 1%	0603	Yageo	RC0603FR-07100KL
3	R12,R15,R17	0	Resistor, 1%	0603	Yageo	
3	R13,R18,R19	300k Ω	Resistor, 1%	0603	Yageo	RC0603FR-07300KL
2	R14,R16	NC		0603	Yageo	
1	U1		PMU	QFN40 5mm*5mm	MPS	MP5600EUT

PRINTED CIRCUIT BOARD LAYOUT

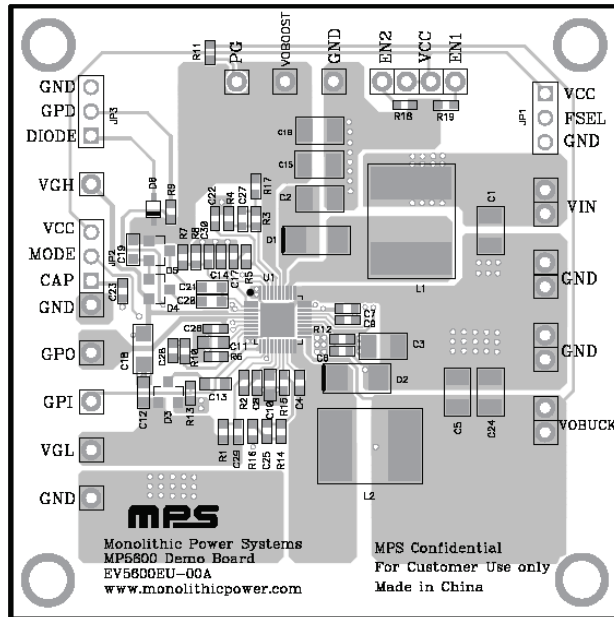

Figure 1—Top Layer

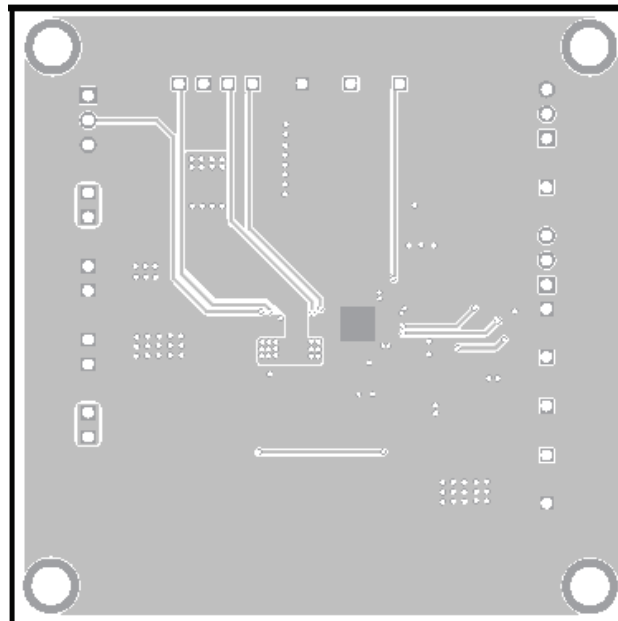

Figure 2—Bottom Layer

QUICK START GUIDE

1. Connect all load to corresponding output channel respectively.
Buck channel: VBUCK, GND
Boost channel: VBOOST, GND
Positive Charge Pump channel: VGH, GND
Negative Charge Pump channel: VGL, GND
2. Connect the positive and negative terminals of the power supply (8V ~ 18V) to the VIN and GND pins, respectively.
3. Select the JUMP EN1 and EN2 to VCC to enable buck and boost channel
4. JP1 set the switching frequency, VCC for high frequency, GND for low frequency.
5. JP2 set the GPO MODE, VCC for MODE1, GND for MODE2.
6. JP3 set the GPD discharge channel, Diode for discharging per VBOOST.
7. For Gate Pulse Management, GPI pin is the control signal input.
8. The power good signal can be monitored on PG pin.

NOTICE: The information in this document is subject to change without notice. Users should warrant and guarantee that third party Intellectual Property rights are not infringed upon when integrating MPS products into any application. MPS will not assume any legal responsibility for any said applications.